

Basin Faucet Installation Manual

W-293(ES)

Warranty Duration

All components of this faucet system are covered under a lifetime limited warranty, ensuring they are free from defects in material and workmanship for the original purchaser.

Repair and Replacement

If the product shows defects in material or workmanship under normal use and within the warranty period, we will, at our discretion, either repair the product or provide a replacement at no cost to the original purchaser. Please note that proof of purchase (e.g., an invoice) is required when requesting service. The warranty does not cover damages caused by improper installation, misuse, or modifications.

Exclusions

We shall not be responsible for the following cases:

- Damage to the product caused by improper installation, misuse, unauthorized repair or replacement, or abuse (including damage during shipment).
- Damage to the product caused by improper dismantling after installation.
- Damage resulting from abnormal water pressure or impurities in water pipes, which is not covered under this warranty.
- Rust on the product due to insufficient care and maintenance, which is not covered under this warranty.
- Damage caused by natural disasters such as fire, flood, earthquake, lightning storms, etc., which is not covered under this warranty.

I hope this helps! If you have any further questions or concerns, please let me know.

Having Trouble? Contact us.

✉ Email: info@faucetsupport.com

☎ Toll Free: 1-888-969-6880



M2416-H
SFS-1121

CONTENT

Basin Faucet Installation Manual ----- (1-3)

CONTENIDO

Manual de Instalación del Grifo para Lavabo ----- (4-6)

Prior to Installation

1. Ensure that all necessary parts are available by referring to the diagram and parts list.
2. Ensure that your basin matches the kitchen faucet size.
3. Do not disassemble the main faucet body, as it has been properly installed and tested before delivery from the factory.
4. Turn off the hot and cold water supply before starting the installation.
5. To prevent the faucet from clogging, flush the water pipes before installation.
6. After completing the installation, check all joints and connections for leaks.

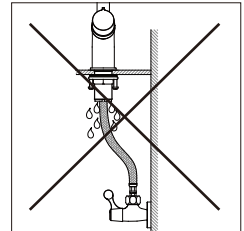
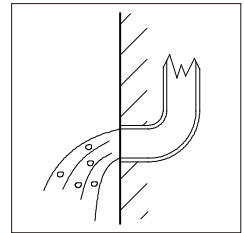
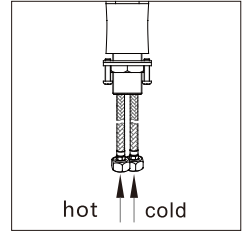

Standard Part List

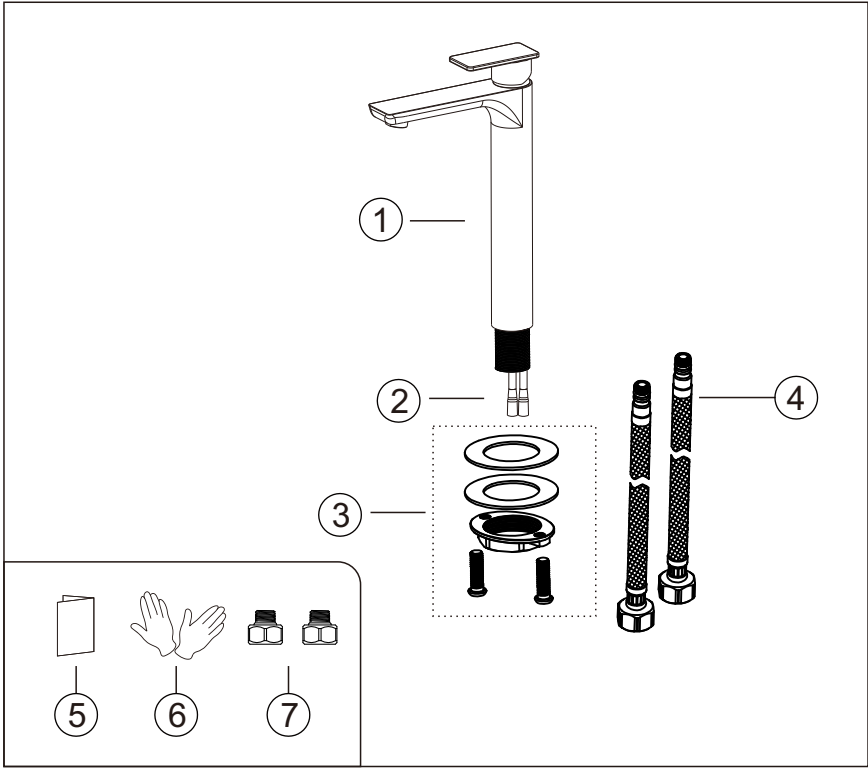

NO.	Part Name	Qty
1	Faucet body	1
2	Extension copper pipe	2
3	Tailpiece nut assembly	1 set
4	Hot and cold inlet pipes	1
5	Installation manual	1
6	Gloves	2
7	Hose adapter change G9/16 to G1/2	2

Installation Step

1

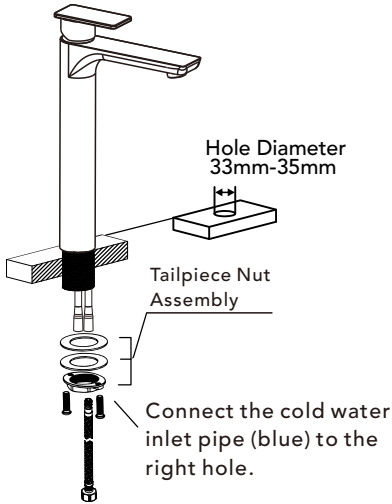

2

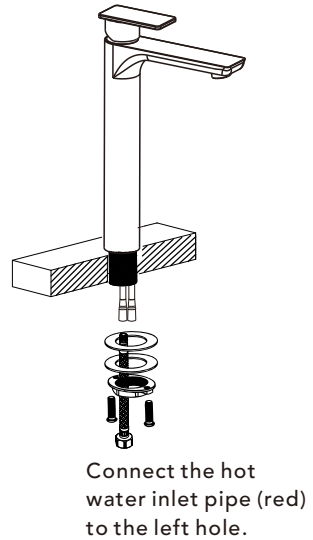

3

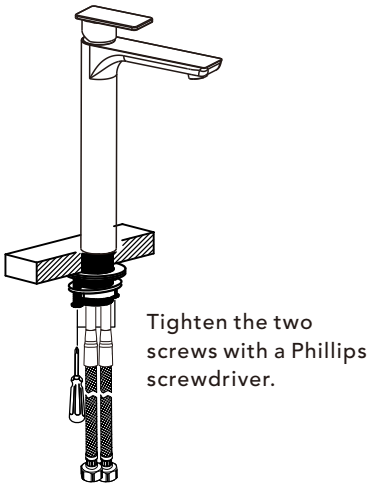

4

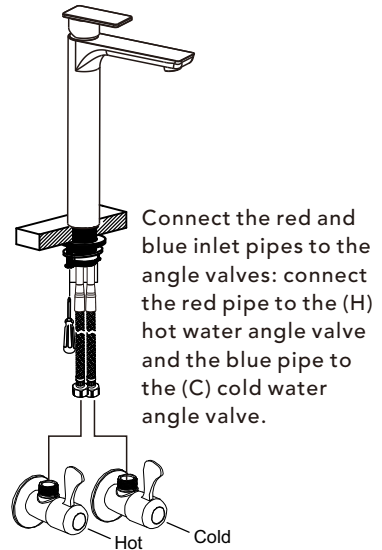

Antes de la instalación

1. Asegúrese de tener todas las piezas necesarias verificando el diagrama y la lista de piezas.
2. Verifique si su lavabo es compatible con el tamaño del grifo del lavabo.
3. No desmonte el cuerpo principal del grifo, ya que ha sido instalado y ajustado correctamente y con precisión antes de su entrega desde la fábrica.
4. Cierre los suministros de agua caliente y fría antes de comenzar.
5. Para evitar que el grifo se obstruya, enjuague la tubería de agua antes de la instalación.
6. Al finalizar la instalación, revise todas las uniones y conexiones para detectar posibles fugas.

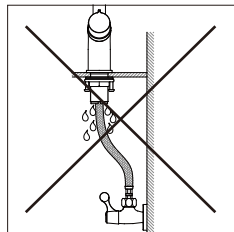
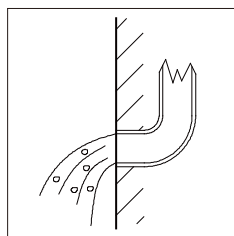
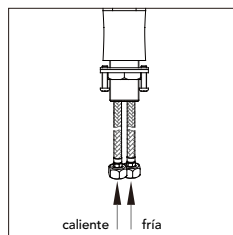

Lista estándar de piezas

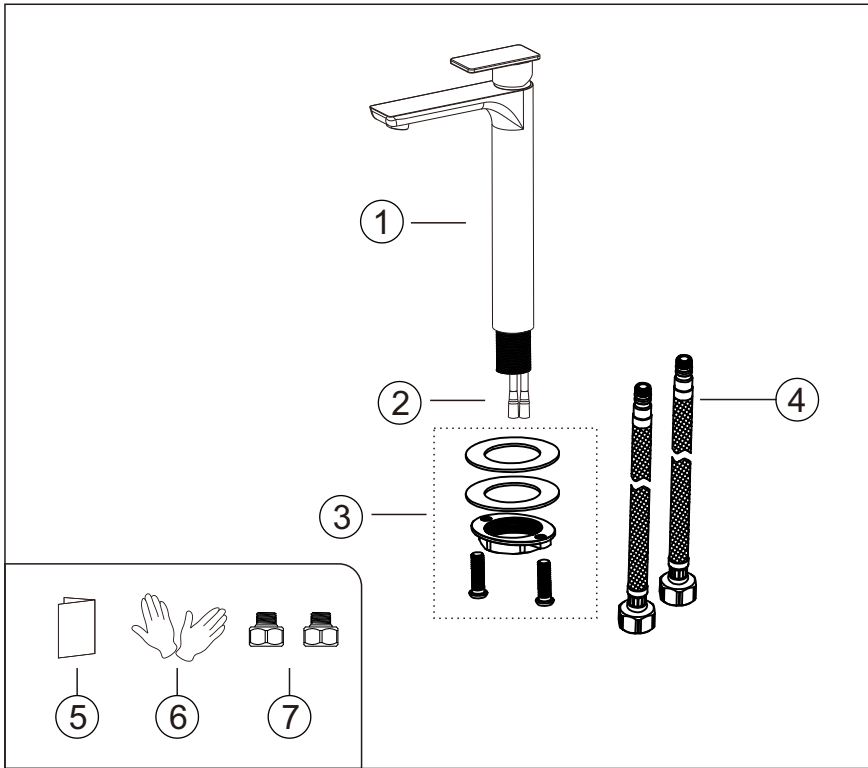

N.º	Nombre de la pieza	Cant.
1	Cuerpo del grifo	1
2	Tubo de extensión de cobre	2
3	Ensamblaje de la tuerca del manguito	1 juego
4	Tuberías de entrada de agua caliente y fría	1
5	Manual de instalación	1
6	Guantes	2
7	Adaptador de manguera para cambiar de G9/16 a G1/2	2

Paso de instalación

1

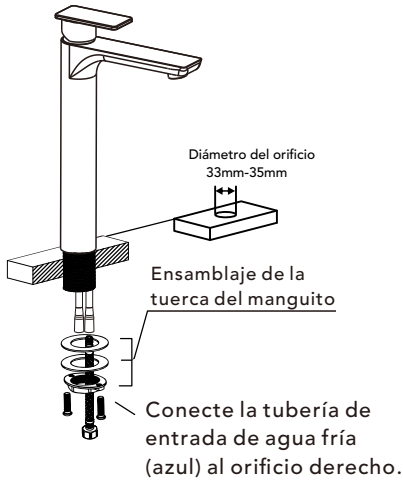

2

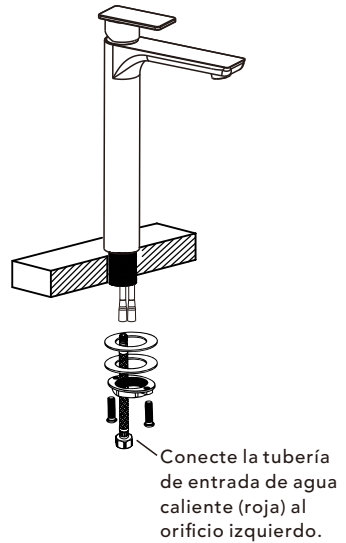

3

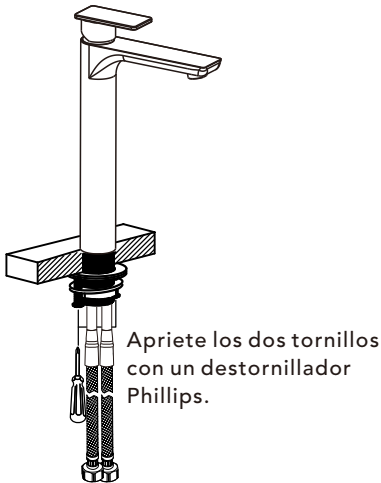

4

