

Freestanding Bathtub Faucet Installation Manual

W-105(ES)

Warranty Duration

All components of this faucet system are covered under a lifetime limited warranty, ensuring they are free from defects in material and workmanship for the original purchaser.

Repair and Replacement

If the product shows defects in material or workmanship under normal use and within the warranty period, we will, at our discretion, either repair the product or provide a replacement at no cost to the original purchaser. Please note that proof of purchase (e.g., an invoice) is required when requesting service. The warranty does not cover damages caused by improper installation, misuse, or modifications.

Exclusions

We shall not be responsible for the following cases:

- Damage to the product caused by improper installation, misuse, unauthorized repair or replacement, or abuse (including damage during shipment).
- Damage to the product caused by improper dismantling after installation.
- Damage resulting from abnormal water pressure or impurities in water pipes, which is not covered under this warranty.
- Rust on the product due to insufficient care and maintenance, which is not covered under this warranty.
- Damage caused by natural disasters such as fire, flood, earthquake, lightning storms, etc., which is not covered under this warranty.

I hope this helps! If you have any further questions or concerns, please let me know.

Having Trouble? Contact us.

 Email: info@faucetsupport.com

 Toll Free: 1-888-969-6880



M5228
SFS-1187

CONTENT

1. Freestanding Bathtub Faucet Installation Instructions ----- (1-6)

CONTENIDO

1. Instrucciones de instalación para grifo de bañera exento ----- (7-12)

◆ Installation and Maintenance Matters

1. Check the accessories list to verify that all parts are complete in this package.
2. Do not disassemble the main body by yourself.
3. Connect inlet pipes to supply valves.
4. Make sure inlet pipes and supply valves have no impurities and are cleaned, with no impurities in the pipeline.
5. After installation, check all joints for leakages.
6. Do not leave the rain shower system exposed to a severely corrosive environment.

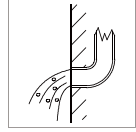
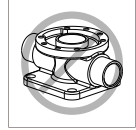

Do's

1. In order to keep the mixer surface bright, please clean the mixer regularly.
2. Rinse the faucet with clean water and wipe it with a soft cotton cloth.
3. Use one of the following cleaners to remove dirt from the surface: a. Mild liquid cleaner. b. Colorless glass cleaner and powder cleaner that do not cause abrasion and can be dissolved completely. c. Polish liquid that does not cause abrasion.

Don'ts

- a. Avoid using cleaning powder, harsh cleaning chemicals, brushes and coarse cloth to prevent scratching and friction.
- b. Do not use acid cleaners to clean the faucet as they may cause surface corrosion of the faucet. If the faucet is exposed to harmful acid substances, please rinse it immediately with water.

Tools Needed:

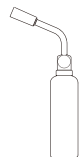
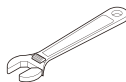
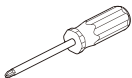

◆ **Freestanding Bathtub Faucet
Accessories List**

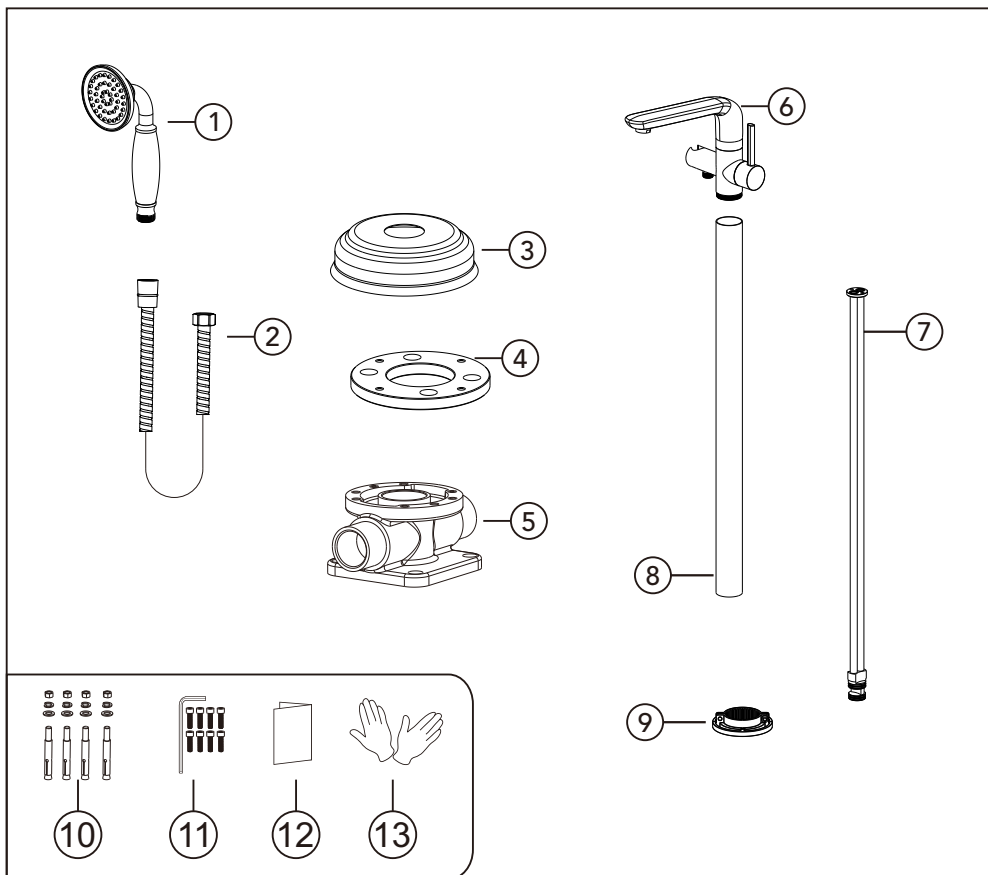

No.	Part name	Qty	No.	Part name	Qty
1	Hand shower	1	8	Bathtub stand pipe	1
2	Shower hose	1	9	Mounting Base	1
3	Decorative cover	1	10	Concealed body parts	1set
4	Mounting plate	1	11	Mounting plate parts	1set
5	Concealed body	1	12	Instruction manual	1
6	Main body	1	13	Gloves	1
7	Water supply tube	1			

◆ Concealed Body Installation Depth

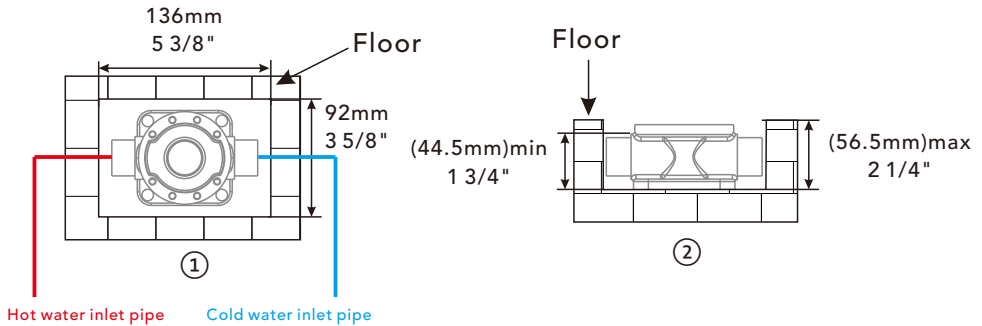

- Notice:** 1. The opening dimensions on the room floor, including length and width, are shown in diagram ①. The installation depth of the embedded body is shown in diagram ②.
2. The dimensions must be between 44.5mm (1 3/4") and 56.5mm (2 1/4").

Accurately connect the hot and cold water inlet pipes according to the "H" (hot) and "C" (cold) markings on the concealed body.

◆ Concealed Body Installation Dimensions

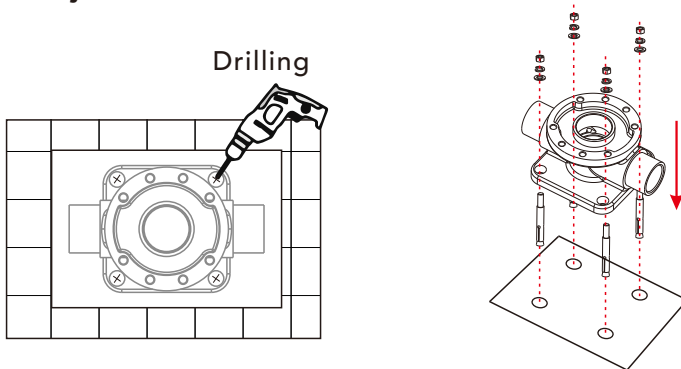

1. Place the concealed body at the center of the prepared hole, mark the positions of the four corresponding screw holes, and use a punch to drill the holes.
 2. Insert the expansion screws into the holes (ensure an appropriate screw length is exposed for securing the main body and nut).
 3. Then align the screw holes of the concealed body with the screws, and finally tighten the nut and washer.
-

◆ Installation Steps

Step 1

Connect the main body to the water supply tube using hex screws, following the direction indicated in the diagram. Make sure to tighten the screws securely; otherwise, leakage may occur.

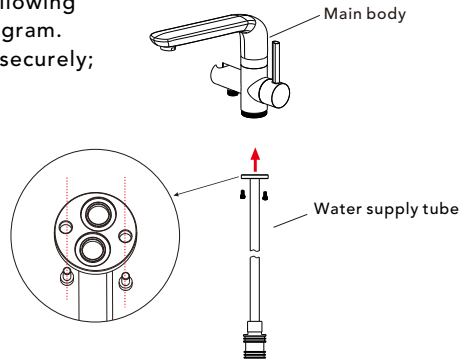

Step 2

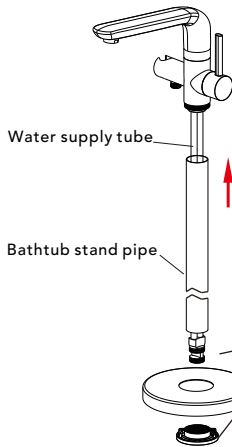

1. Insert the bathtub stand pipe into the water supply tube following the direction shown in the diagram until it reaches the external thread of the main body. Then, tighten it clockwise.
2. Slide the decorative cover and the mounting base upward into the bathtub stand pipe from below. Once the mounting base is aligned with the locking position, securely fasten it with screws.

◆ Installation Steps

Step 3

Install the fully assembled component into the pre-installed main body, and tighten the screws.

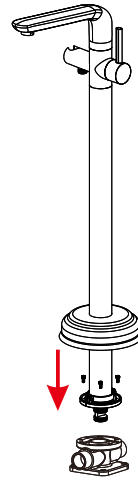

Step 4

Connect the handheld shower, shower hose, and bathtub faucet as shown in the diagram.

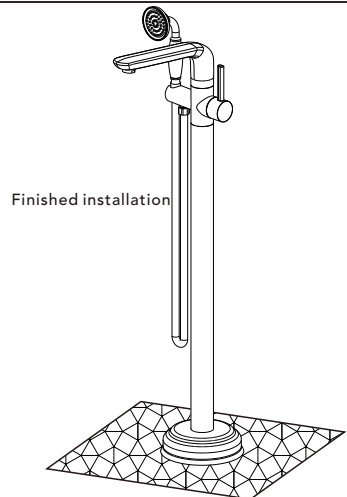
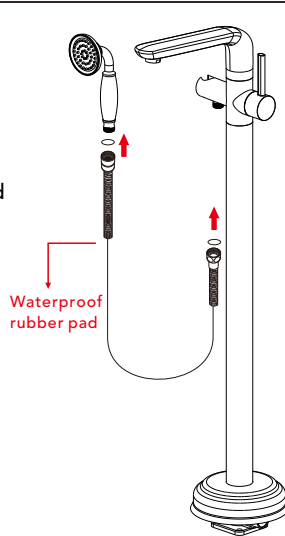

◆ Introduction to Features

1. This handle is an integrated control for both water outlet selection and temperature adjustment.
2. In the initial position (as illustrated), the handle is in the OFF position and the water supply is shut off.
Turn the handle to the left to activate one water outlet. The further you turn to the left, the higher the water temperature.
Turn the handle to the right to switch to the other water outlet. The further you turn to the right, the higher the water temperature.

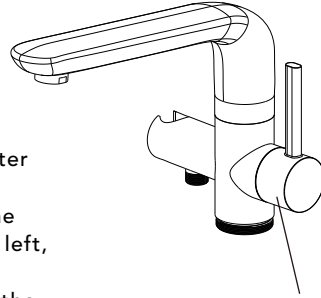

Integrated diverter and temperature control switch

◆ Instalación y cuestiones de mantenimiento

1. Verifique la lista de accesorios para comprobar que todas las partes están completas en este paquete.
2. No desmonte el cuerpo principal por sí mismo.
3. Conecte las tuberías de entrada a las válvulas de suministro.
4. Asegúrese de que las tuberías de entrada y las válvulas de suministro no tengan impurezas y estén limpias, sin impurezas en la tubería.
5. Después de la instalación, revise todas las juntas en busca de fugas.
6. No deje el sistema de ducha expuesto a un ambiente severamente corrosivo.

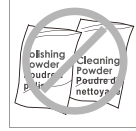
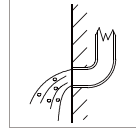
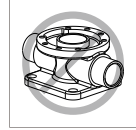
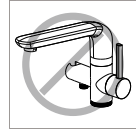

Hacer

1. En para mantener la superficie de la batidora brillante, limpie el mezclador regularmente.
2. Inse el grifo con agua limpia y límpielo con un suave ropa de algodón.
3. Use uno de los siguientes limpiadores para eliminar la suciedad de la superficie:
A. Mild Liquid Cleaner.
B. Cleaner de vidrio sin color y limpiador de polvo que no causar abrasión y se puede disolver por completo.
C. Polish Líquido que no causa abrasión.

No es decir

- A. Valte con polvo de limpieza, productos químicos de limpieza duros, cepillos y tela gruesa para evitar rascar y fricción.
- B. No use limpiadores de ácidos para limpiar el grifo, ya que pueden causar corrosión superficial del grifo. Si el grifo está expuesto a sustancias ácidas dañinas, enjuague inmediatamente con agua.

Herramientas Necesarias:

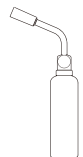
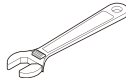
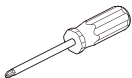

◆ Grifo de Bañera Independiente
Lista de Accesorios

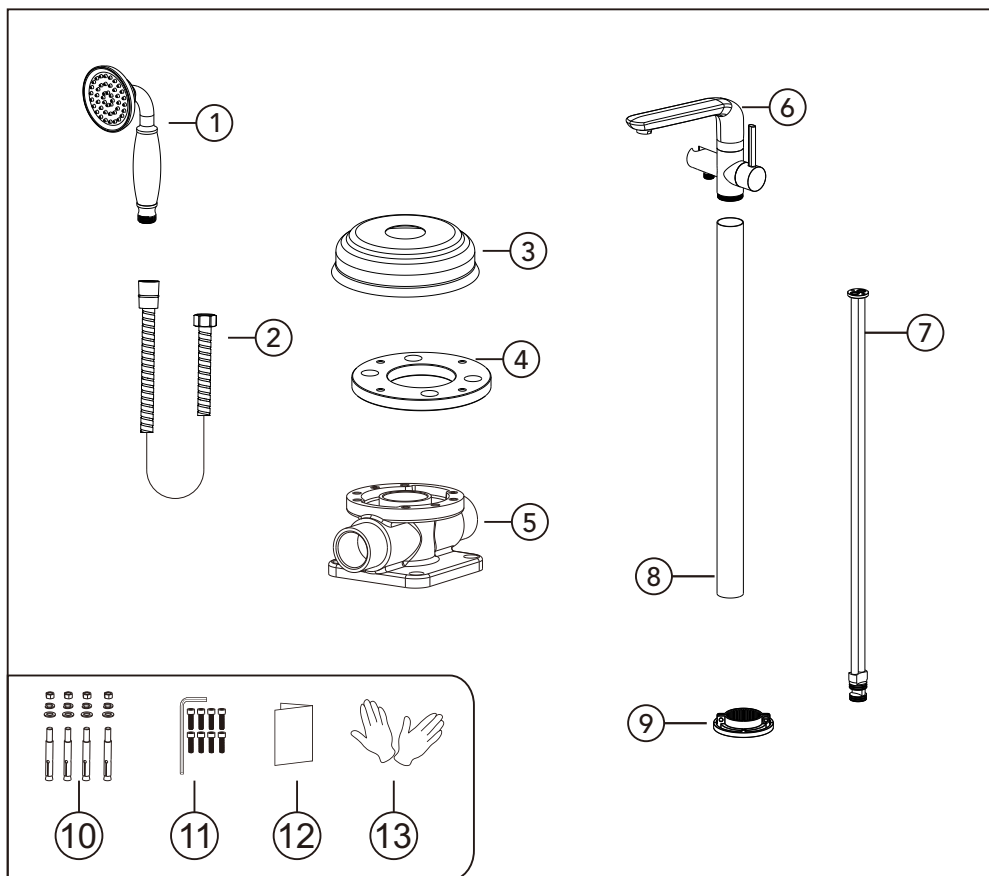

N.º	Nombre de la pieza	Cant.	N.º	Nombre de la pieza	Cant.
1	Ducha de mano	1	8	Tubo de soporte para bañera	1
2	Manguera de ducha	1	9	Base de montaje	1
3	Cubierta decorativa	1	10	Piezas del cuerpo empotrado	1 juego
4	Placa de montaje	1	11	Piezas de la placa de montaje	1 juego
5	Cuerpo empotrado	1	12	Manual de instrucciones	1
6	Cuerpo principal	1	13	Guantes	1
7	Tubo de suministro de agua	1			

◆ Profundidad de Instalación del Cuerpo Empotrado

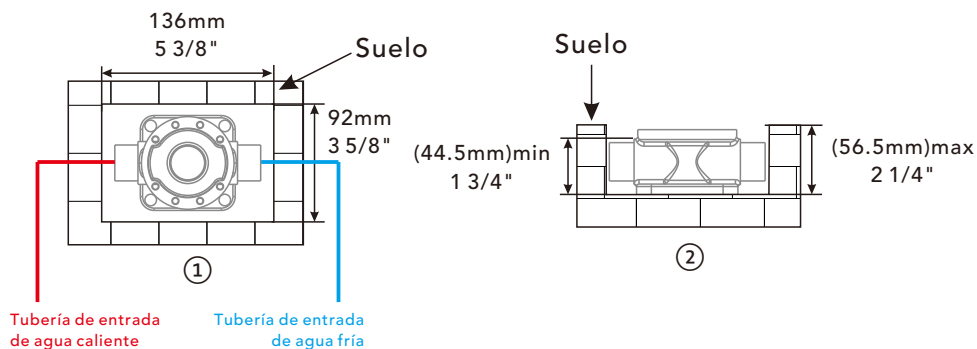

Aviso: 1. Las dimensiones de la apertura en el suelo de la habitación, incluyendo el largo y el ancho, se muestran en el diagrama ①. La profundidad de instalación del cuerpo empotrado se muestra en el diagrama ②.

Conecte con precisión las tuberías de entrada de agua caliente y fría de acuerdo con las marcas "H" (caliente) y "C" (fría) en el cuerpo empotrado.

◆ Dimensiones de Instalación del Cuerpo Empotrado

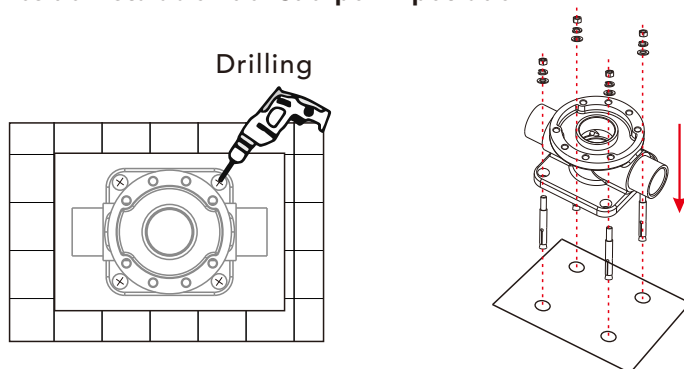

1. Coloque el cuerpo empotrado en el centro del orificio preparado, marque la posición de los cuatro orificios correspondientes para los tornillos y utilice un punzón para perforarlos.
2. Inserte los tornillos de expansión en los orificios (asegúrese de que quede expuesta una longitud adecuada del tornillo para fijar el cuerpo principal y la tuerca).
3. Luego, alinee los orificios del cuerpo empotrado con los tornillos y, finalmente, apriete la tuerca y la arandela.

◆ Pasos de Instalación

Paso 1

Conecte el cuerpo principal al tubo de suministro de agua utilizando tornillos hexagonales, siguiendo la dirección indicada en el diagrama.

Asegúrese de apretar bien los tornillos; de lo contrario, podría producirse una fuga.

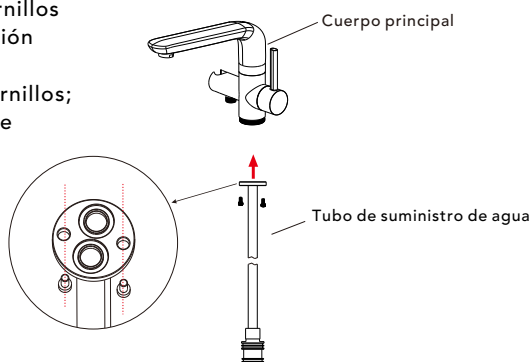

Paso 2

1. Inserte el tubo de soporte de la bañera en el tubo de suministro de agua siguiendo la dirección indicada en el diagrama, hasta que alcance la rosca externa del cuerpo principal. Luego, apriételo en sentido horario.

2. Deslice la cubierta decorativa y la base de montaje hacia arriba, introduciéndolas desde abajo en el tubo de soporte de la bañera. Una vez que la base de montaje esté alineada con la posición de fijación, asegúrela firmemente con tornillos.

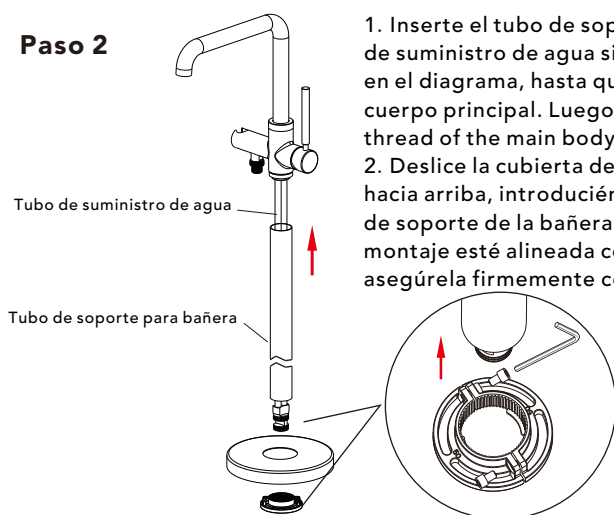

◆ Pasos de Instalación

Paso 3

Instale el componente completamente ensamblado en el cuerpo principal preinstalado y apriete los tornillos.

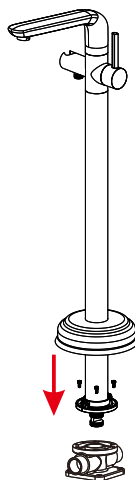

Paso 4

Conecte la teleducha, la manguera de ducha y el grifo de la bañera según se muestra en el diagrama.

Almohadilla de goma impermeable

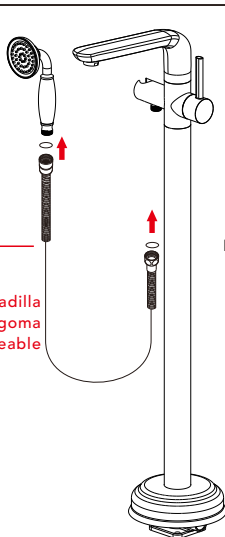

Instalación finalizada

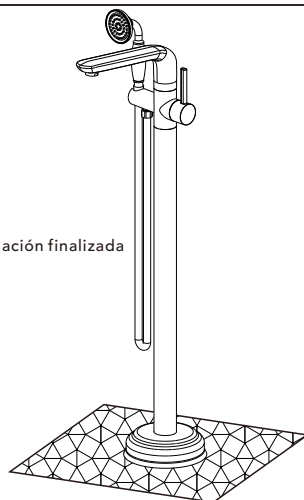

◆ Presentación de las Características

1. Esta manija es un control integrado tanto para la selección de la salida de agua como para el ajuste de la temperatura.
2. En la posición inicial (como se ilustra), la manija está en la posición OFF y el suministro de agua está cerrado.

Gire la manija hacia la izquierda para activar una salida de agua. Cuanto más la gire hacia la izquierda, mayor será la temperatura del agua.

Gire la manija hacia la derecha para cambiar a la otra salida de agua. Cuanto más la gire hacia la derecha, mayor será la temperatura del agua.

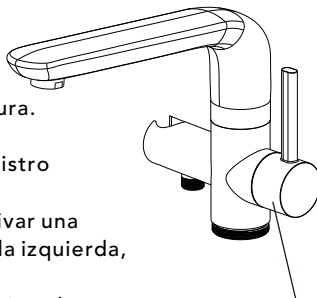

Integrated diverter and temperature control switch