

SWISHER®

Versa – Tractor

Commercial Pro Land Management System



Model #: VT389H

Description: Versa Tractor, 389cc Honda

SWISHER ACQUISITION INC.

1602 Corporate Drive, Warrensburg Missouri 64093

Phone: 660-747-8183 FAX: 660-747-8650

Toll Free: 1-800-222-8183

**Manufacturing quality lawn care equipment since 1945,
Celebrating over 70 years of innovation**



4/6/2021

OWNER'S MANUAL

STARTING SERIAL # L120-288001

TABLE OF CONTENTS

LIMITED WARRANTY	3
INTRODUCTION	4
FEATURES	5
CONTROLS	6
SAFETY INSTRUCTION	7-8
GENERAL USE	7
CHILD SAFETY, SLOPE OPERATION	8
MAINTENANCE, TRAINING, OPERATION	8
SYMBOLS & DECALS	9
UNCRATING & ASSEMBLY	10
CUSTOMER RESPONSIBILITY	11-12
OPERATOR PRESENCE, TIRES	11
V-BELTS, OVERALL UNIT CARE	11
DRIVING & TRANSPORT ON PUBLIC ROADS	11
SPECIFICATIONS, MAINTENANCE SCHEDULE	12-13
OPERATION	14-15
STARTING INSTRUCTIONS	14
PARKING BRAKE	14
BYPASS OPERATION	14
CONNECTING ATTACHMENTS	15
OPERATING THE POWER UNIT	16
SERVICE & ADJUSTMENT	17-18
TRACKING AND DRIVE ADJUSTMENT	17
BELT REPLACEMENT/ADJUSTMENT	18
PTO SHAFT, GEARBOX	18
TROUBLESHOOTING	19
UNIT IDENTIFICATION	20
REPLACEMENT PARTS	21
PARTS BREKDOWN	22-36
ENGINE ASSEMBLY	22
PUMPS / PUMP MOUNTING	23-24
CLUTCH STOP ASSEMBLY	24
PTO SHAFT ASSEMBLY	25
IDLER ASSEMBLIES	26
WHEEL MOTORS / LOWER MOTORBASE	27
UPPER MOTORBASE ASSEMBLY	28
CONTROLS / CONTROL TOWERS	29-32
OIL COOLER	33
MAIN ASSEMBLY	34
BRAKE / KICKSTAND	35
COVERS / WHEEL-TIRES	36
ELECTRICAL SYSTEM	37
HYDRAULIC SYSTEM	38
NOTES	39
SWISHER HISTORY	40

LIMITED WARRANTY

The manufacturer's warranty to the original consumer purchaser is:

This product is free from defects in materials and workmanship for a period of three (3) years for residential use and one (1) year for commercial use from the date of purchase by the original consumer purchaser.

We will repair or replace, at our discretion, parts found to be defective due to materials or workmanship. This warranty is subject to the following limitations and exclusions:

- 1) Limitations This warranty applies only to products which have been properly assembled, adjusted, and operated in accordance with the instructions contained within this manual. This warranty does not apply to any product of Swisher that has been subject to alteration, misuse, abuse, improper assembly or installation, shipping damage, or to normal wear of the product.
- 2) Exclusions Excluded from this warranty are normal wear, normal adjustments, normal maintenance, and battery.
- 3) Engine Warranty All engines utilized on our products have a separate warranty extended to them by the individual engine manufacturer. Any engine service warranty is the responsibility of the engine manufacturer and in no way is Swisher or its agents responsible for the engine warranty. The Honda Engine Service website is engines.honda.com. The Kawasaki Engine Service Hotline is 1-877-364-6404 or email kawpower-website@kmc-usa.com.

In the event you have a claim under this warranty, you must deliver the product to an authorized service dealer. All transportation charges, damage or loss incurred during transportation of parts submitted for replacement or repair under this warranty shall be borne by the purchaser. Should you have any questions concerning this warranty, please contact us toll-free at 1-800-222-8183. The model number, serial number, date of purchase and the name of the authorized Swisher dealer from whom you purchased the mower will be needed before any warranty claim can be processed.

THIS WARRANTY DOES NOT APPLY TO ANY INCIDENTAL OR CONSEQUENTIAL DAMAGES AND ANY IMPLIED WARRANTIES ARE LIMITED TO THE SAME TIME PERIODS STATED HEREIN FOR ALL EXPRESSED WARRANTIES. Some states do not allow the limitation of consequential damages or limitations on how long an implied warranty may last, so the above limitations or exclusions may not apply to you. This warranty gives you specific legal rights and you may have other rights, which vary from state-to-state. This is a limited warranty as defined by the Magnuson-Moss Act of 1975.

INTRODUCTION

Congratulations! Thank you for purchasing Swisher's Versa Land Management System. With this versatile system you will be able to tackle all of your toughest jobs in all seasons. **This manual is a valuable document. Following the instructions for use, service, maintenance, etc. can greatly increase the performance and life of your machine.**

NOTE: If you have never used a Hydrostatic Drive Equipment before, refer to the Operation Controls section of this manual before attempting to operate one for the first time.



THIS SAFETY ALERT SYMBOL IDENTIFIES AN IMPORTANT SAFETY MESSAGE IN THIS MANUAL THAT HELPS YOU AND OTHERS AVOID PERSONAL INJURY OR EVEN DEATH. DANGER, WARNING AND CAUTION ARE SIGNAL WORDS USED TO IDENTIFY THE LEVEL OF HAZARD. HOWEVER, REGARDLESS OF THE HAZARD, BE EXTREMELY CAREFUL.

DANGER: Indicates an **IMMINENTLY HAZARDOUS SITUATION!** If not avoided, **WILL RESULT** in death or serious injury.

WARNING: Indicates a **POTENTIALLY HAZARDOUS SITUATION!** If not avoided, **COULD RESULT** in death or serious injury.

CAUTION: Indicates a **POTENTIALLY HAZARDOUS SITUATION!** If not avoided, **MAY RESULT** in minor or moderate injury. It may also be used to alert against unsafe practices.

General:

IMPORTANT! In this operator's manual, left and right, backward and forward are used in relation to the normal operator's position on the tractor.

Read Before Operating:

- The manufacturer's directions concerning operation, maintenance and repairs must be carefully followed.
- This machine must only be operated, maintained and repaired by persons who are familiar with the machine's special characteristics and who are well versed in safety instructions.
- Accident prevention regulations, other general safety regulations, occupational safety rules and traffic regulations must be followed without fail.
- Unauthorized modifications to the design of the machine may absolve the manufacturer from liability for any resulting personal injury or property damage and may void the warranty.
- Read and observe all safety instructions on your mower and in the manual.

Refer to the operations manual for the following instructions:

- Know how to set the parking brake – Push down on brake lever with foot until it locks in place.
- Know how to turn working attachment off – PTO switch pushed down.
- Know how to stop the engine – Turn key to off or in emergency flip emergency shut off switch.
- Know how to stop the unit – Return control handles to neutral.

FEATURES

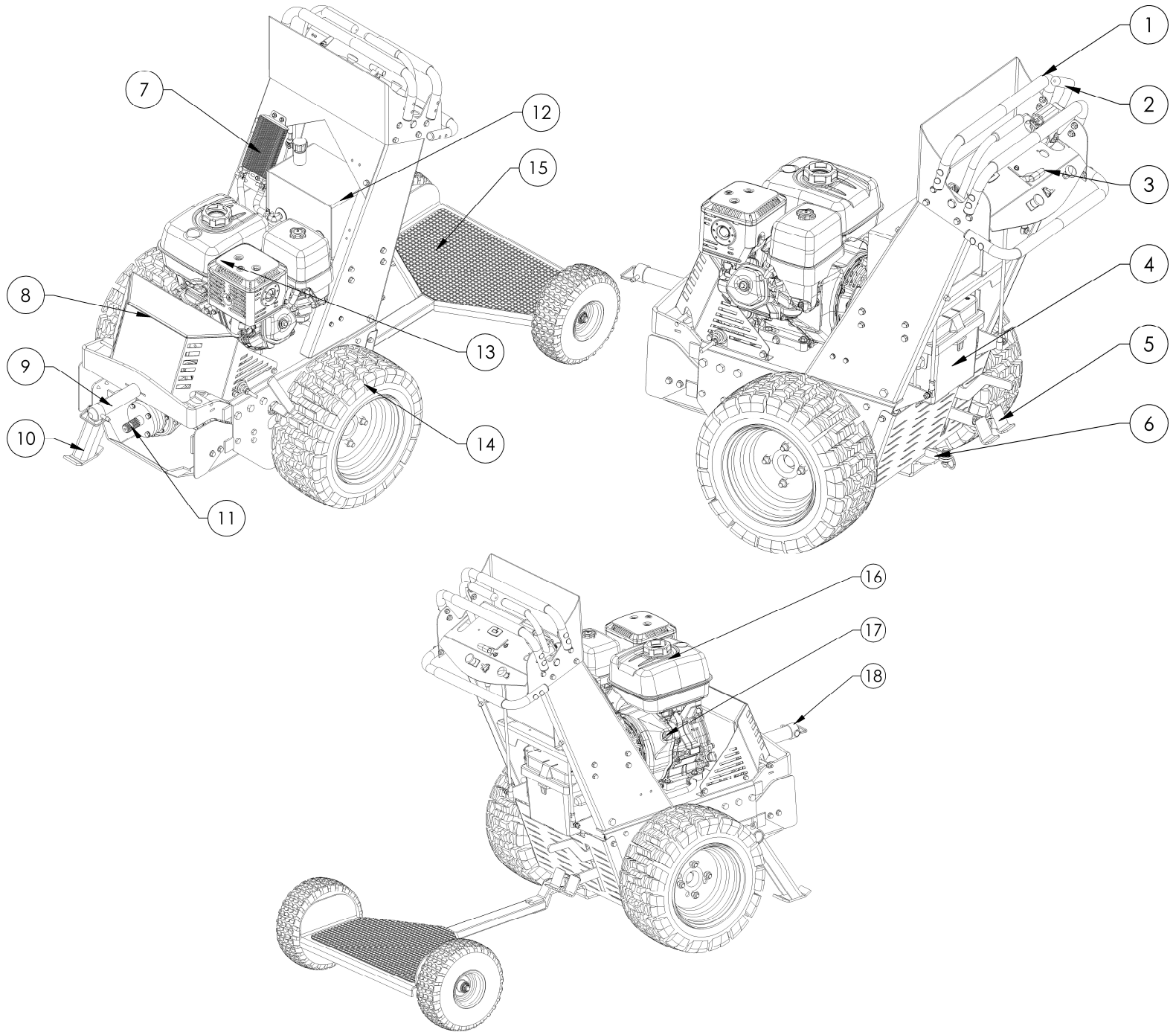

- | | |
|------------------------------|----------------------------|
| 1 Adjustable Stabilizer Bars | 10 Power Unit Stand |
| 2 Control Levers | 11 PTO Drive |
| 3 Control Panel | 12 Hydraulic Reservoir |
| 4 Battery (UL1 Type) | 13 Engine |
| 5 Brake / Brake Release | 14 All-Terrain Drive Tires |
| 6 Hitch | 15 Sulky |
| 7 Hydraulic Oil Cooler | 16 Fuel Tank |
| 8 Belt Covers | 17 Ignition Switch |
| 9 Quick Attatch Pin | 18 Locking Collar |

CONTROLS

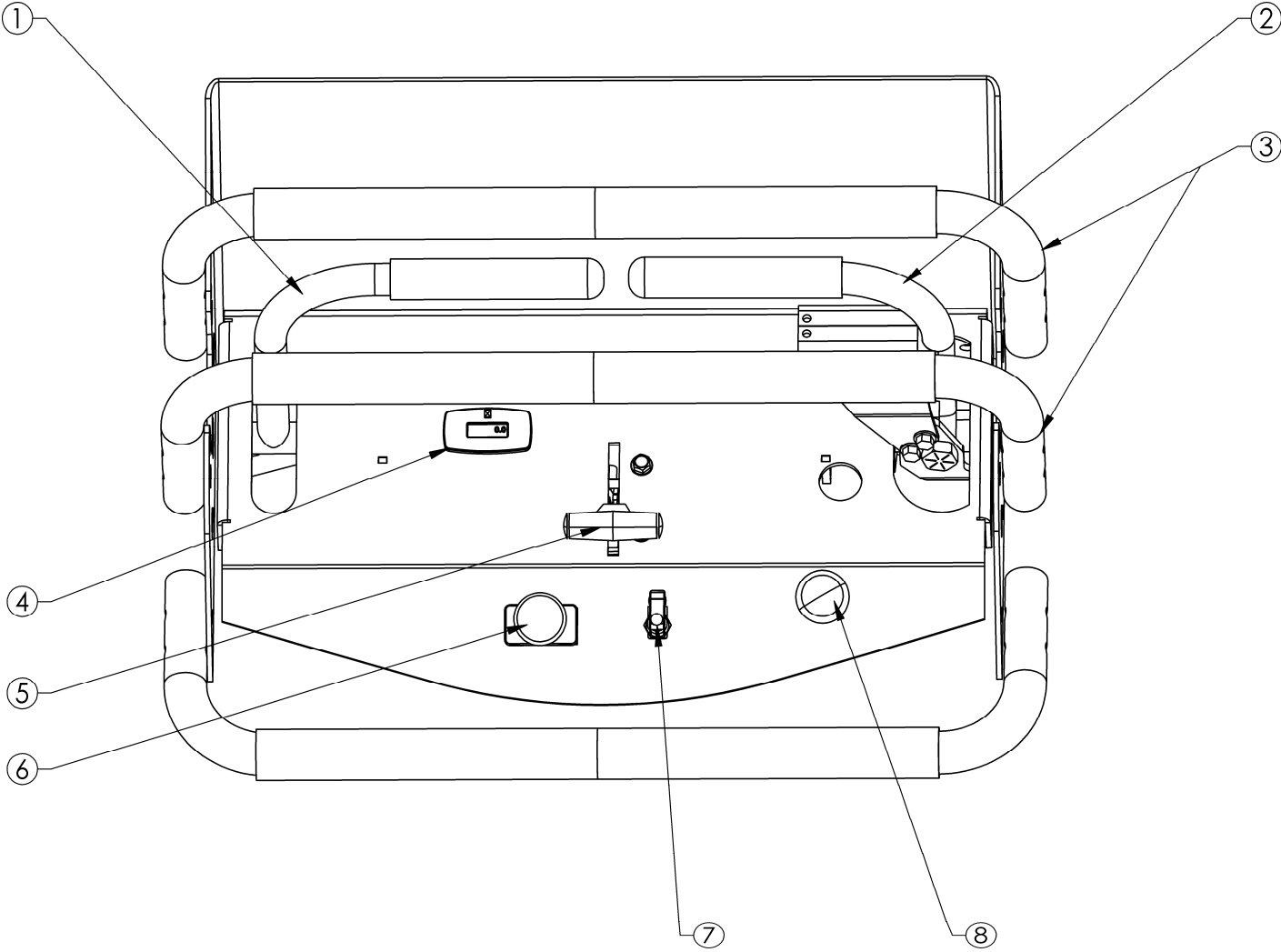

- 1 Directional Controls-Left Wheel
- 2 Directional Controls-Right Wheel
- 3 Adjustable Stabilizer Bars
- 4 Digital Hour Meter
- 5 Throttle Control
- 6 PTO Engage/Disengage
- 7 Emergency Shut Off
- 8 Engine Choke Control

Note: Refer to the Operating Instructions on page 13-15 for complete directions on operating the unit.

SAFETY INSTRUCTIONS

These instructions are for your safety. Read them thoroughly & carefully.



This Safety Alert Symbol indicates important messages in this manual. When you see this symbol, carefully read the message that follows and be alert to the possibility of personal injury.



General Use:

- Read all instructions in this operator's manual and on the machine before starting it. Ensure that you understand them and then abide by them.
- Learn how to use the machine, operate its controls safely, how to stop quickly and recognize safety decals.
- Only allow the machine to be used by adults who are familiar with its use and operation.
- Make sure nobody else is in the area of the machine when you start the engine, engage the drive or operate the machine.
- Stop the machine if someone enters the work area.
- Clear the area of any objects such as stones, toys, etc. that may be caught or thrown by the blades.
- **DO NOT use this machine without the Guards or Belt Covers in place.**
- Stop the engine and disconnect the spark plug before performing maintenance checks.
- Never attempt to inspect the PTO shaft with the engine running and always remove the ignition key and spark plug wires before clearing debris.
- Never take passengers. The machine is only intended for use by one person.
- Always look around before and during reversing maneuvers.
- Slow down before turning.
- Disengage the attachment when not in use.
- Be careful when rounding fixed obstacles so that the attachment does not hit them.
- Keep the machine a safe distance from holes or other irregularities in the ground.
- Never use the machine if you are tired, if you have consumed alcohol or if you are taking other drugs or medications that can affect your vision, judgment or coordination.
- Beware of traffic when working near or crossing a road.
- Never leave the machine unsupervised with the engine running.
- Always disengage the attachment, engage the parking brake, stop the engine and remove the ignition key before leaving the machine.
- Never allow children or other persons not trained in the use of the machine to use or service it. Local laws may regulate the age of the user.
- Make sure that you have first aid equipment close at hand when using the machine.
- Always make sure long hair is not left down when servicing and/or operating the machine. Make sure hair is out of the way of any moving parts or pinch points.
- Inspect the attachment and tractor before each use. Make sure all hardware is in place and tightened properly.
- Make sure this attachment is in good operating condition and properly connected and secured.
- Check and double check that the drive line PTO locking collar moves freely and is securely engaged to the tractor's PTO groove.
- Never use the machine when barefoot. Always wear protective shoes or boots.
- Always wear protective glasses or full visor and hearing protection when assembling or operating.
- Never wear loose clothing that can get caught in moving parts.
- Check that any safety or informational decals are in place and legible. Replace any damaged decals.

Safety instructions continued on next page....

Remember: The operator is responsible for avoiding dangers or accidents.



WARNING



When using the machine, approved personal protective equipment shall be used. Personal protective equipment cannot eliminate the risk of injury, but it will reduce the degree of injury if an accident does occur. Ask your retailer for help in choosing the right equipment.



SAFETY INSTRUCTIONS

These instructions are for your safety. Read them thoroughly & carefully.



This Safety Alert Symbol indicates important messages in this manual. When you see this symbol, carefully read the message that follows and be alert to the possibility of personal injury.



Children:

- Children are often attracted to power equipment. Serious accidents may occur if you fail to be on guard for children in the area of the machine.
- Never assume that children will stay put where you last saw them.
- Keep children away from the work area and under close supervision by another adult.
- Shut off the machine if children enter the work area.
- Never allow a child to ride with you.
- Never allow children to operate the machine.
- Be extra cautious near corners, bushes, trees or other objects that block your view.

Slope Operation:

- Remove obstacles such as stones, tree branches, etc.
- Operate side to side not up and down. Never drive the mower on terrain that slopes more than 15 degrees.
- Avoid starting or stopping on a slope. If the tires begin to slip, disengage the PTO and drive slowly down the slope.
- Always drive evenly and slowly on slopes.
- Do not make sudden changes in speed or direction.
- Avoid unnecessary turns on slopes. If it becomes necessary, turn slowly and gradually downward if possible.
- Watch for holes, ruts or bumps. On uneven terrain, the machine can tip more easily. Long grass or other debris can hide obstacles.
- Drive slowly and use small movements of the steering controls.
- Do not operate wet grass. It is slippery, and the tires can lose their traction, allowing the machine to slide.

Maintenance & Storage:

- Keep all nuts, bolts and screws tight to be sure the equipment is in safe working condition.
- If storing equipment over long periods of time remove all grass clippings, grass build up and debris from the equipment to prevent corrosion.
- Replace worn or damaged parts for continued safe operation.
- When machine is to be parked, stored or left unattended the parking brake should be set .
- Remove the ignition key to prevent unauthorized use.

Training:

All users should seek and obtain professional and practical instruction. Such instruction should emphasize:

- The need for care and concentration when working with walk behind or ride-on machines.
- How to properly connect and disconnect the tractor and attachment.
- How to properly drive, control and operate a walk behind or ride-on machine with an attachment connected.

Operation Safety:

- Do not operate the machine in a confined space.
- Always disengage PTO, set parking brake, turn the engine off and remove the key when leaving the machine during operations.
- Never direct discharge of material toward bystanders or allow anyone near the machine while in use.
- Never operate the machine near bodies of water, retaining walls, cliffs or tall curbs. Give the machine ample room to operate and turn around.
- Never operate the machine with defective guards or without safety protective devices in place.
- Disengage the PTO switch, set the brake, stop the engine, remove the ignition key and disconnect the spark plug wires:
 - Before clearing blockages.
 - Before checking, clearing or working on the machine.
 - After striking a foreign object, inspect the machine for damage and make repairs before restarting and operating the equipment.
 - If the machine starts to vibrate abnormally (check immediately).
 - Before making height adjustment unless adjustment can be made from the operator's position.

SYMBOLS & DECALS



This Safety Alert Symbol indicates important messages in this manual. When you see this symbol, carefully read the message that follows and be alert to the possibility of personal injury.



Danger / Entanglement - 19486



Master Shut-Off Switch Decal - 21793



Notice Do Not Alter Wiring Decal - OD74



Serial # ID Tag

Uncrating Instructions

Tools Required:

- Tire pressure gauge
- Nail bar or claw hammer
- Wire snips
- Protective eyewear

To remove the tractor from the crate:

- Position crate on a flat, level surface
- Dispose of top and side panels of the crate.
- Remove packing material.
- Cut any banding or strapping that may be holding the tractor to the crate.
- Disconnect the spark plug wire and place where it cannot make a connection.
- Remove and dispose of all wheel chocks that are holding the machine in place.
- Open the transmission bypasses by turning bypass ports with provided wrench one full turn.. **SEE INSTRUCTION ON PAGE 13 OF OWNER'S MANUAL.**
- Carefully roll the tractor off the crate to a safe and level area.
- Check engine oil. All engines are filled with oil and tested at the factory. Verify oil level and add if necessary before starting engine. **SEE ENGINE OWNER'S MANUAL FOR OIL GRADE AND PROCEDURES.**
- Check the battery; It may need to be charged with a 12 volt charger for a minimum of one hour, but no more than 2 hours at a rate of 6 to 10 amps.
- Close the transmission bypasses by tightening the ports back to original position. Be sure that both ports are **TIGHT**. **SEE INSTRUCTION ON PAGE 13 OF OWNER'S MANUAL.**
- Reconnect spark plug wire.
- Check tire pressure on both drive wheels. **REFER TO UNIT SPECIFICATIONS TABLE ON PAGE 12 OF OWNER'S MANUAL.**
- **Read all operating instructions, safety instructions and customer responsibilities before operating this machinery.**

CUSTOMER RESPONSIBILITIES



WARNING

STOP THE ENGINE AND DISCONNECT THE SPARK PLUGS BEFORE MAKING ANY ADJUSTMENTS TO THE MACHINE!

Operator Presence System:

- Be sure to check that the operator presence and interlock systems are working properly before every use. If your attachment does not function as described, repair the problem immediately.
- The Control Levers must be in the neutral position in order for the machine to start. If the controls are not exactly at neutral the unit will not start.
- The attachment wire harness must be connected in order to run the PTO system. If it is not properly or securely connected, the PTO will not engage.

➤ **The right side control lever acts as the operator presence and depending on the attachment will need to be in either position “A” or position “B” to activate the attachment.**

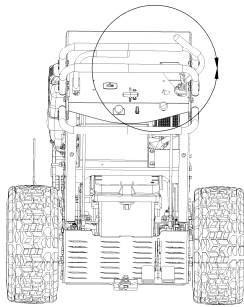

POSITION “A”

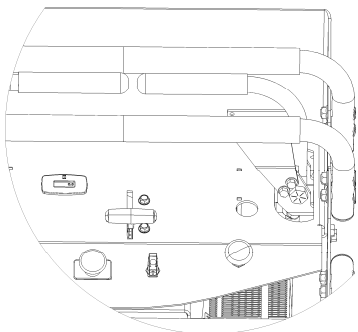

POSITION “B”

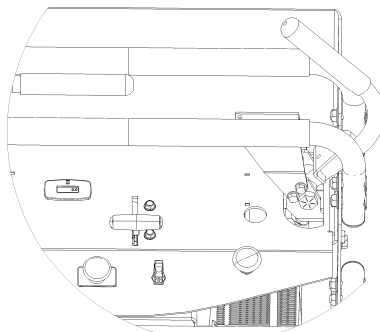

V-Belts:

Check V-belts for deterioration and wear before each use and replace if necessary. Replace belts if they begin to slip from wear. Refer to Quick Reference and Service & Adjustment sections of this manual for instructions on belt part numbers and how to properly replace belts.

Tires:

- Maintain proper air pressure in all tires (SEE SPECIFICATIONS section)
- Keep tires free of gasoline, oil or insect control chemicals which can harm rubber.
- Avoid stumps, stones, deep ruts, sharp objects and other hazards that may cause tire damage.
- If operating in an area with thorns, it is recommended to fill the tires with sealant.

Overall Unit Care:

- Reduce the risk of fire by removing grass, leaves and other debris that may accumulate on the machine.
- Allow the machine time to cool before cleaning or putting it in storage.
- Wash mower periodically. Clean above and below deck.
- Keep all electrical connections clean and secure.
- Remove any debris from around hydraulic system such as the oil cooler, pumps and wheel motors to ensure the system does not overheat.

Driving & Transport on Public Roads:

- Check applicable road traffic regulations before driving and transporting on public roads.
- If the machine is transported, you should always use approved fastening equipment and ensure that the machine is well anchored to the towing vehicle.



WARNING

When it is necessary to tilt the unit for any repair or service, use safety chains and/or jack stands to provide adequate support. DO NOT rely on hydraulic or mechanical jacks.



WARNING

Do not overinflate the tires. Serious injury can occur if the tire explodes



CAUTION

Stop engine, apply brakes, and remove ignition key for safety. Disconnect spark plug wires. Wear heavy, thick gloves when holding onto blade. Avoid the sharp edge of the blade.

CUSTOMER RESPONSIBILITIES

Specifications

PTO DRIVE	Electric Magnetic Clutch
ARTICULATION DIRECTION(S)	Front to Back & Side to Side
TIRE SIZE	18 X 850 -10 w/ 4X4 Lug
TIRE PRESSURE	40 PSI Max
3/8-16 ENGINE MOUNTING BOLT TORQUE	33 FT LBS
3/8-16 PTO SHAFT BEARING MOUNTING BOLT TORQUE	33 FT LBS
BATTERY	12V / Heavy Duty 340 CCA / Type U1L
HYDRAULIC FLUID	20W50 Oil
ENGINE OIL	SAE 30 W
UNIT MEASUREMENTS	LENGTH: 47" WIDTH: 35.5" HEIGHT: 47.5" WEIGHT: 486 lbs

Maintenance Schedule

	Before Each Use	8 Hours	25 Hours	50 Hours	100 Hours	Season	Before Storage
Check Tire Pressure	X	X					
Check Operator Presence	X						
Check for Loose Fasteners	X				X		X
Check Hydraulic Fluid Level	X		X				
Grease PTO Shaft Bearings (see page 24 for lubrication points)				X2			
Check Belts	X						
Change Engine Oil				X1			
Change Hydraulic Oil					X		
Remove Any Debris	X					X	X

1 – Change more often when operating under a heavy load or in high ambient temperatures.

2 – Service more often when operating in dirty or dusty conditions.

TORQUE SPECIFICATIONS REFERENCE GUIDE

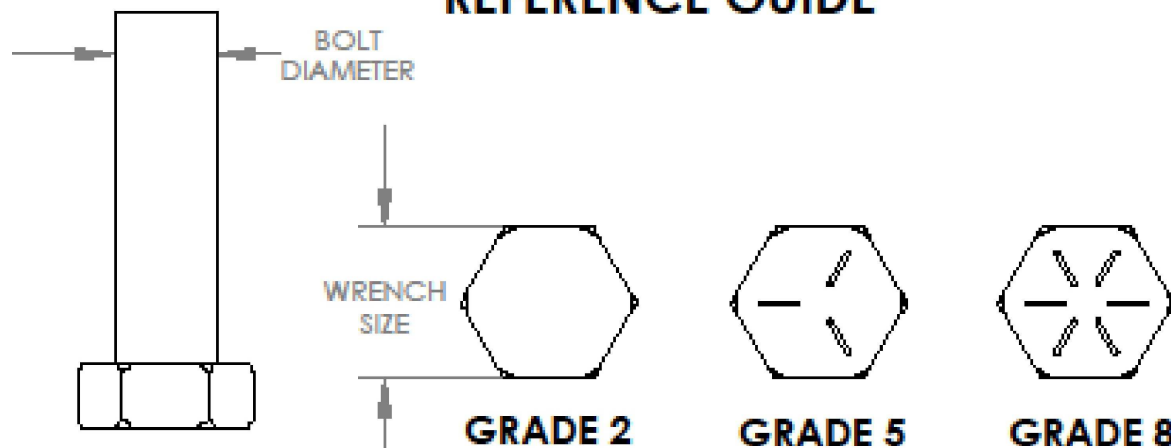

Bolt Diameter (INCH)	Wrench Size	SAE GRADE 2 lb-ft (Nm)		SAE GRADE 5 lb-ft (Nm)		SAE GRADE 8 lb-ft (Nm)	
1/4	7/16	5.5	(7)	9	(12)	12.5	(17)
5/16	1/2	11	(15)	18	(24)	26	(35)
3/8	9/16	20	(27)	33	(45)	46	(62)
7/16	5/8	32	(43)	52	(70)	75	(102)
1/2	3/4	50	(68)	80	(108)	115	(156)
9/16	7/8	70	(95)	115	(156)	160	(217)
5/8	15/16	100	(136)	160	(217)	225	(305)
3/4	1-1/8	175	(237)	280	(380)	400	(542)
7/8	1-5/16	175	(237)	450	(610)	500	(678)
1	1-1/2	270	(366)	540	(732)	750	(1017)
1-1/8	1-11/16	300	(407)	675	(915)	1075	(1457)
1-1/4	1-7/8	425	(576)	950	(1288)	1500	(2034)

Torque values are for reference. 10% variance is allowable. Use these values unless specific torque values are given for a specific application.

Fasteners should be replaced with the same grade. Make sure fasteners threads are clean and that you properly start thread engagement. This will prevent them from failing when tightening.

Tighten toothed or serrated-type lock nuts to the full torque value.

OPERATION

Starting:

- Before starting the tractor, be sure the area is clear of any people or animals.
- Control handles must be in the neutral lockout position.
 - Emergency shut-off switch must be in the upright position
 - PTO switch must be in the disengaged position (pushed down).
 - Turn ignition key until engine starts. If the engine struggles to start, engage the choke until the engine fires, then disengage the choke before operating.
- Once started, increase the engine RPM to desired speed based on the application.

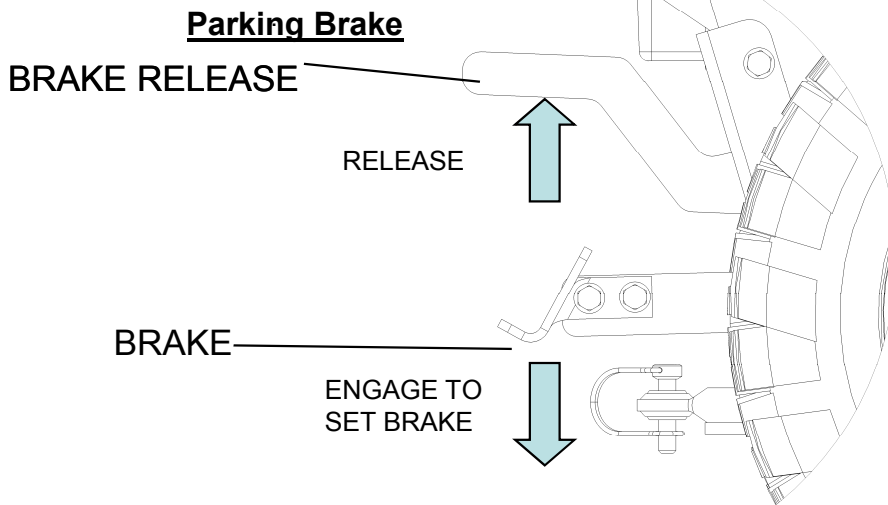

Engaging and Disengaging the Drive System:

- To free wheel the tractor drive wheels, the bypass must be engaged.
- To disengage the drive system you must turn the bypass on both pumps counter-clockwise using the bypass wrench provided up to one full turn to fully release.
- Each bypass is located on the inside of the drive tires towards the front of the motor base.
- To engage drive system you must turn the bypass clockwise using the bypass wrench provided until tight.

BYPASS WRENCH

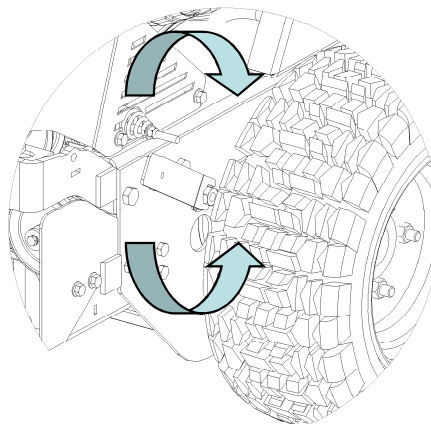
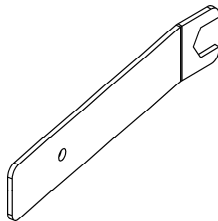

PTO Operation

- The PTO engagement/disengagement is located on the control panel of the tractor.
- To engage the PTO system pull up on the PTO switch
- To disengage the PTO system push down on the switch.
- Not all attachments will require a PTO.
- If the attachment does require a PTO drive then a wiring harness will be provided with that attachment and will be required to be plugged into the tractor harness in order for the PTO system to operate.

⚠ WARNING

Carbon Monoxide. A running engine gives off carbon monoxide, a poisonous gas that can kill you. Do not operate the engine in an enclosed area. Only operate in a well ventilated area.

⚠ DANGER

The PTO shaft turns at a High rate of speed. If the shaft coupler is not secured properly at both ends the shaft could fly loose with enough force to cause serious injury or death!

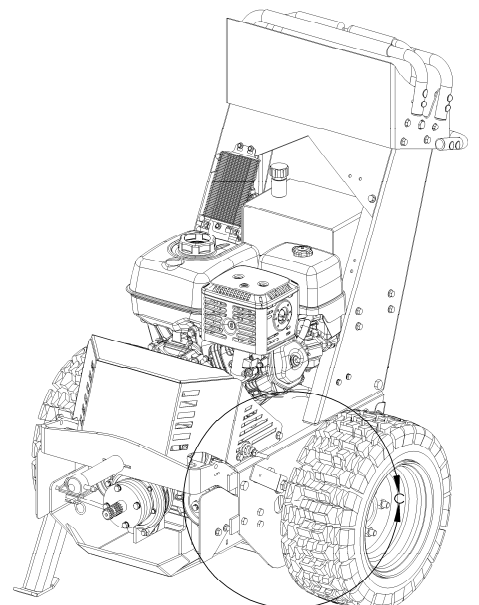

OPERATION

Connecting and Disconnecting Implements

- Always make sure that the tractor and attachment are both on flat ground before attempting to connect or disconnect the units.
- Always check that there are no children around that can be harmed when connecting or disconnecting units.
- Always check that there are no other persons around the immediate area that could potentially activate the tractor.

Connecting

1. Remove any covering necessary on the attachment.
2. Roll or drive the tractor into the attachment by inserting the pivot shaft into the pivot tube of the attachment. It may be necessary to assist the connection by applying the brake to the tractor and sliding the attachment onto the shaft.
3. Once connected, secure the attachment by installing locking collar and pin onto the pivot shaft.
4. Connect PTO shaft if provided with attachment.
5. Replace any guards removed in Step 1.

Disconnecting

1. Make sure the brake on the tractor is on and the PTO is disengaged before attempting to disconnect the unit.
2. Make sure the engine is off and the key is removed from the ignition.
3. Remove any guarding necessary on the attachment and disconnect the PTO shaft from the tractor if provided.
4. Unpin the locking collar and remove from the pivot shaft.
5. Carefully slide the tractor and attachment apart. The tractor can be running and driven away from the attachment if necessary.

VRC30 Attachment Shown Below

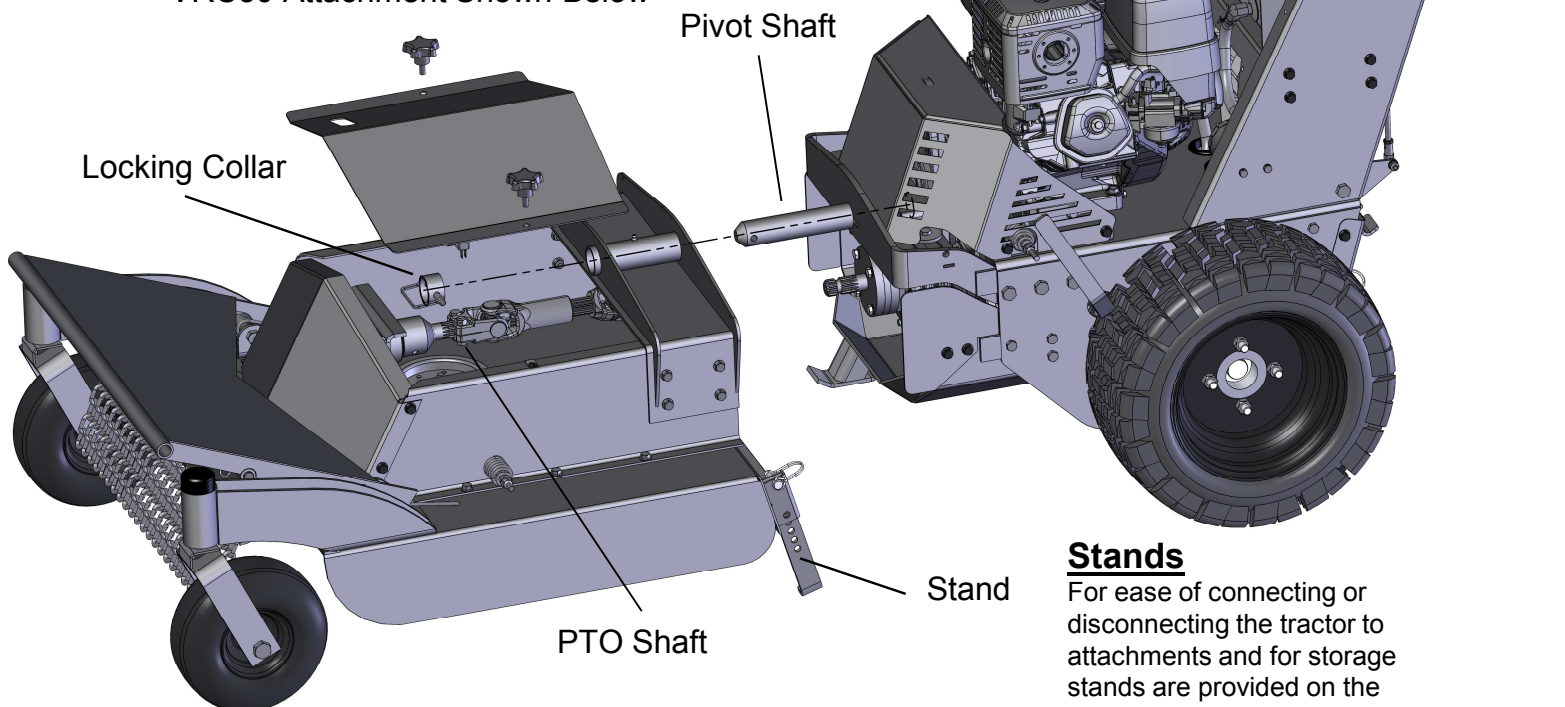

WARNING

ALWAYS BE CERTAIN THE SLIDING LOCKING COLLAR “SNAPS“ INTO PLACE AND IS SECURE ON THE TRACTOR’S SPLINED SHAFT ANYTIME CONNECTING AN ATTACHMENT WHERE A PTO SHAFT IS PROVIDED.

DANGER

The PTO shaft turns at a High rate of speed. If the shaft coupler is not secured properly at both ends the shaft could fly loose with enough force to cause serious injury or death!

Stands

For ease of connecting or disconnecting the tractor to attachments and for storage stands are provided on the tractor and some attachments.

OPERATION

Controls

- Be familiar with all controls, their functions and how to operate them before starting the machine.
- Motion control levers on each side control the direction of movement. SEE FIGURE BELOW
- When operating use smooth, controlled movements on the control handles. Using quick, erratic movements can cause the machine to become out of control.

Control Handles

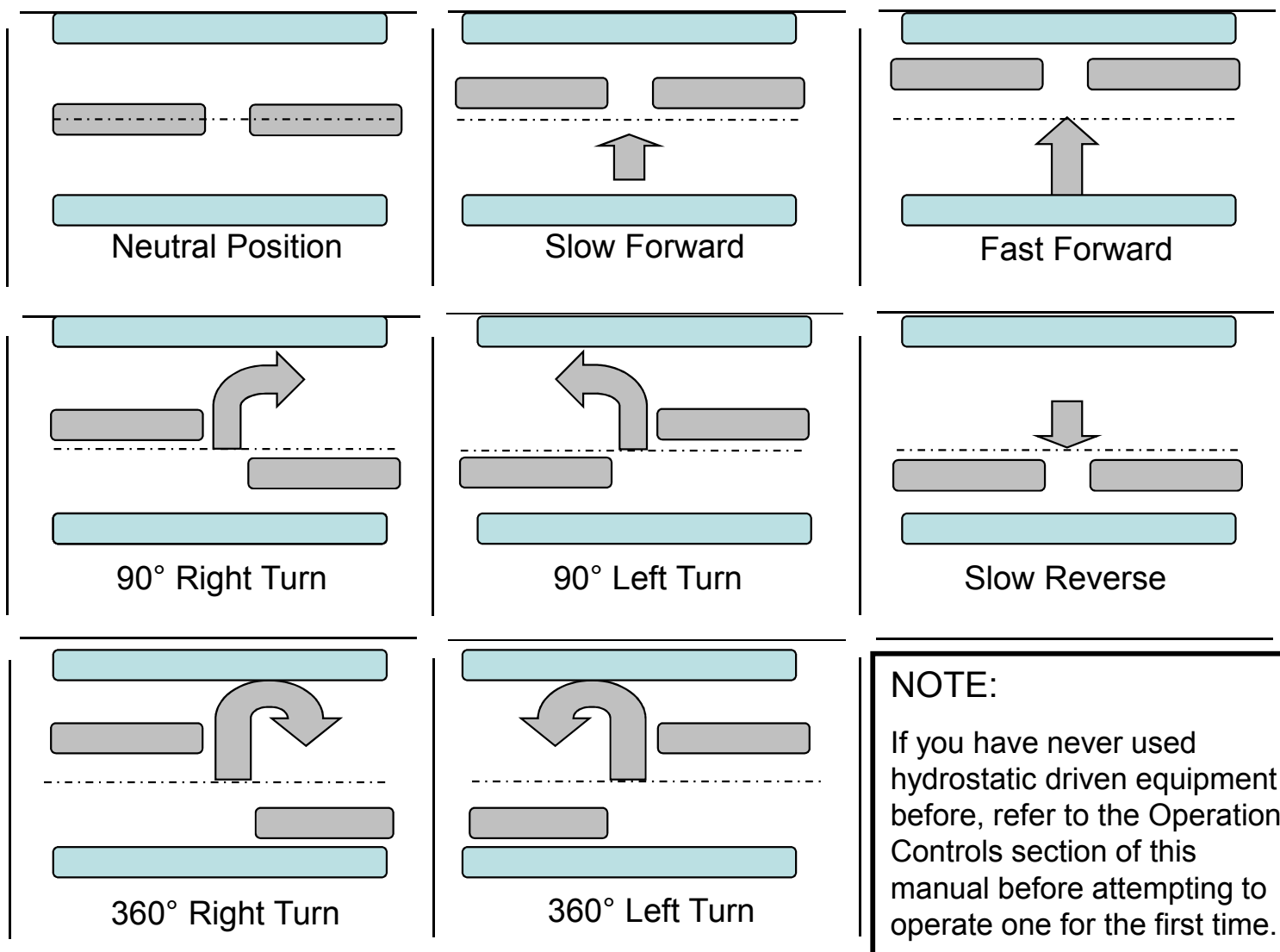

NOTE:

If you have never used hydrostatic driven equipment before, refer to the Operation Controls section of this manual before attempting to operate one for the first time.

Note: The force required to operate the mower control handles is minimal.

SERVICE & ADJUSTMENTS

Adjusting Travel Speed and Drive Tracking

- Both the front (A) and rear (B) stabilizer bars can be adjusted inward and outward to obtain a greater ground speed or restrict ground speed in both forward and reverse travel by loosening the mounting bolts (C). After desired setting is applied make sure the mounting bolts are tightened.
- To adjust the tracking of the control levers, both the left and right directional controls (D&E), the control rods (F) can be adjusted longer or shorter by loosening the adjustment nut (G) and pivot (H). After desired setting is applied make sure the nut and pivot are tightened.

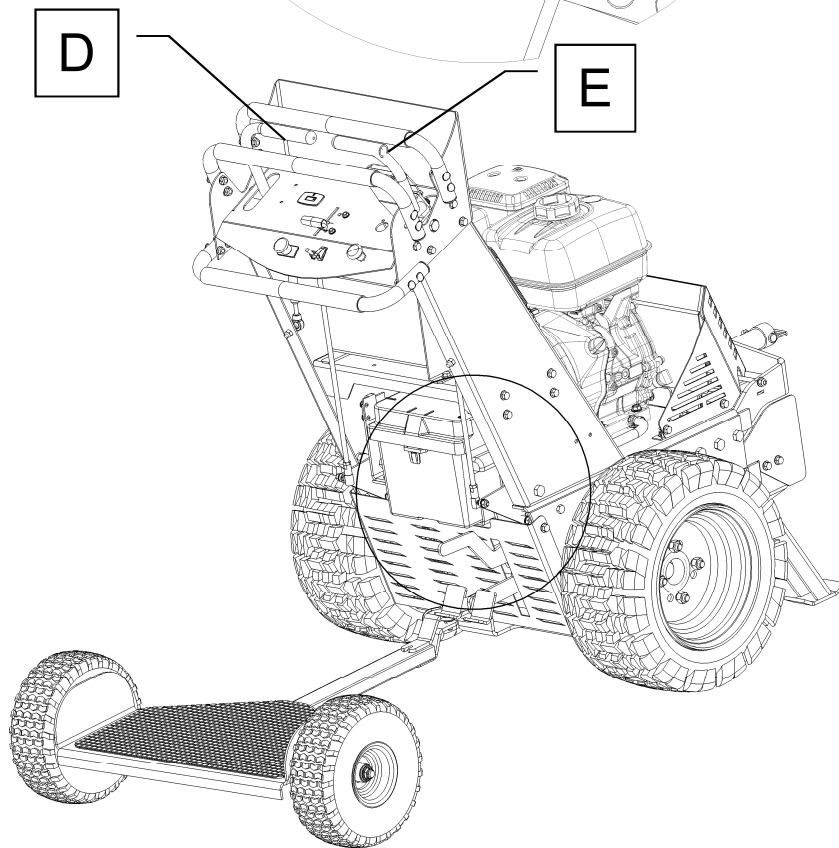
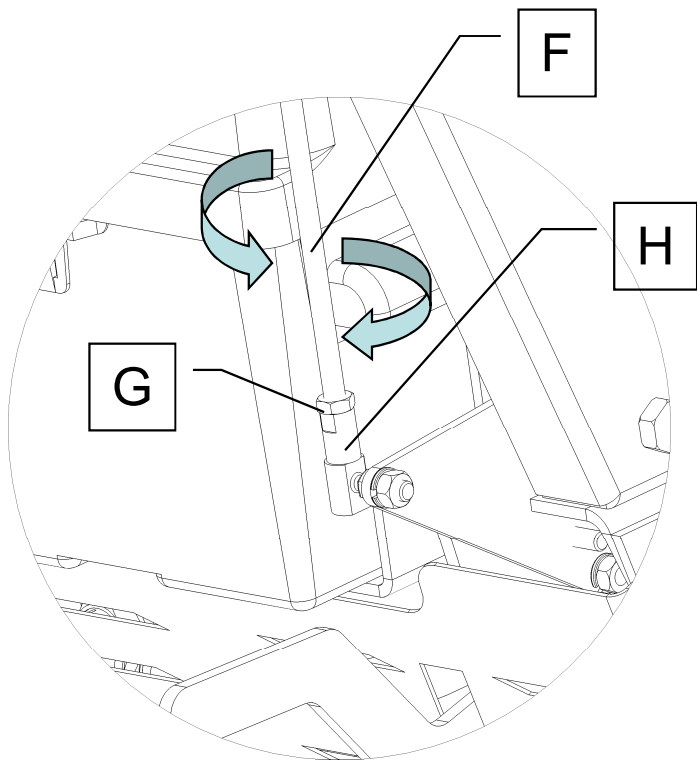
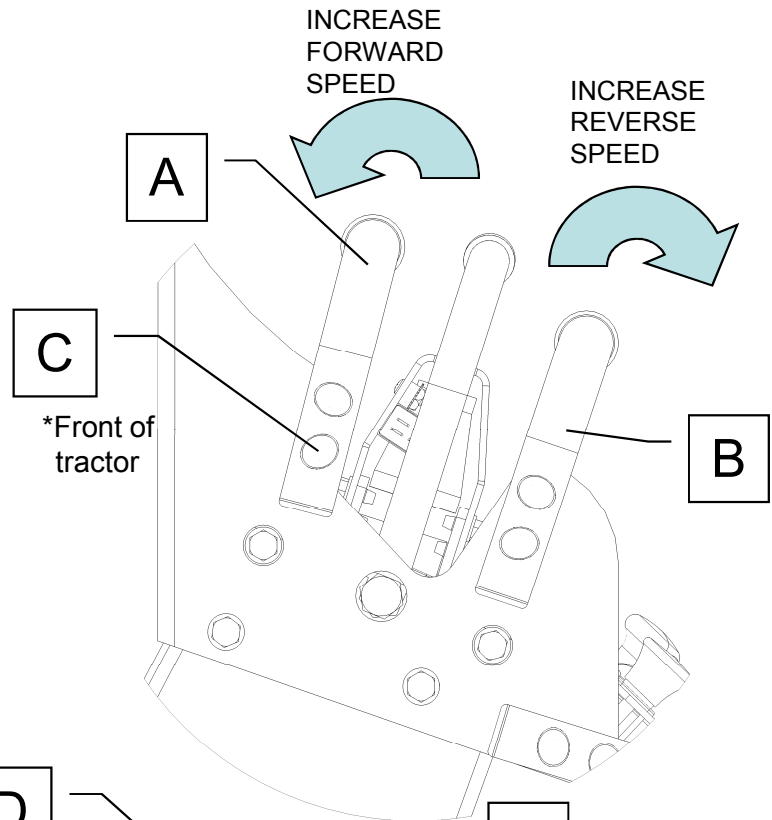

SERVICE & ADJUSTMENTS



WARNING

STOP THE ENGINE AND DISCONNECT THE SPARK PLUGS BEFORE MAKING ANY ADJUSTMENTS TO THE MACHINE!

PTO Shaft

- Before every use, check to make sure the PTO shaft is securely attached to both the tractor and attachment gearboxes.
- Before every use, check the PTO shaft u-joints to make sure they are not damaged or worn. Simply lift up and down on the shaft when it is securely connected to both pieces of equipment. If there is excessive movement then the PTO shaft may need to be replaced.
- If there is excessive vibration during operation, disengage the PTO switch, set the brake, stop the engine, remove the ignition key and disconnect the spark plug wire(s) and immediately inspect the PTO shaft. Refer to Troubleshooting section.
- It is recommended to grease all PTO Shaft joints every 8 hours (50 hours for extended intervals).
- Lubricate all fittings with a good quality lithium soap compatible EP grease meeting the N.L.G.I. #2 specification and containing no more than 1% Molybdenum Disulfide.
- An EP grease meeting the N.L.G.I. #2 specification and containing 3% Molybdenum Disulfide may be substituted in the telescoping members only.

Gearbox

- The gearboxes are lubricated and sealed components. If used and maintained properly, these gearboxes do not require lubrication changes.
- If there are internal component failures within the gearbox, it is recommended to replace the entire gearbox.
- However, if the failed internal components are serviced and/or replaced then new lubrication is required.
- This gearbox requires 4 oz. of Bentonite grease. A recommended brand is Brooks Benalene 900-P-RP.

Belt Adjustment and Reference

- To remove or install either belt the front cover (page 35) and clutch stop assembly (page 23) must be removed

PTO BELT ADJUSTMENT

PUMP BELT ADJUSTMENT

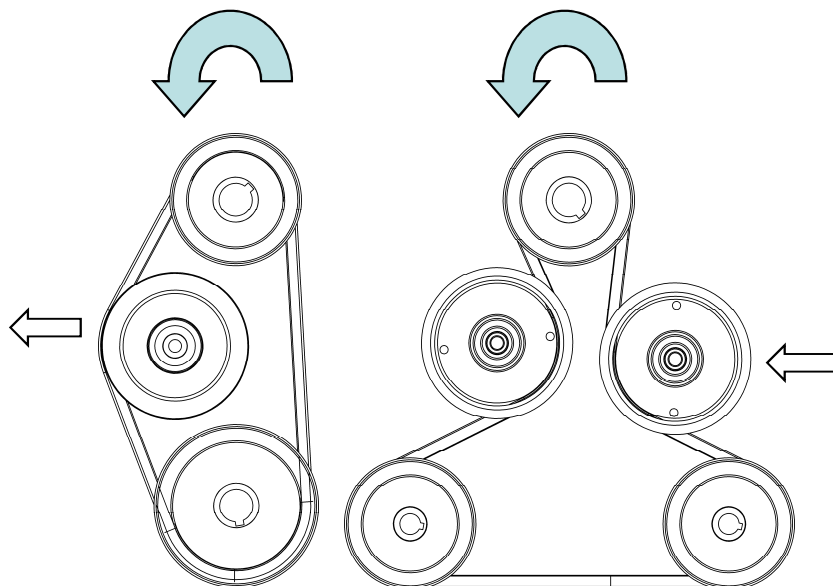
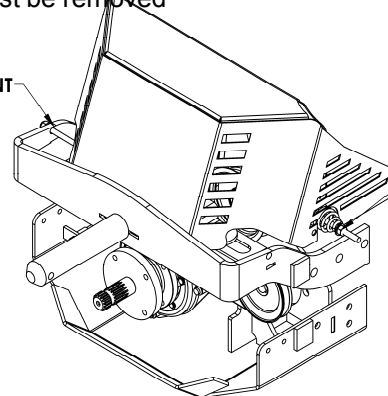

PTO BELT

PUMP/DRIVE BELT

VIEW FROM ENGINE SHAFT

3

2

1

2

1. Telescoping Shaft Grease Point
2. U-Joint Grease Point(s)
3. Sliding Locking Collar

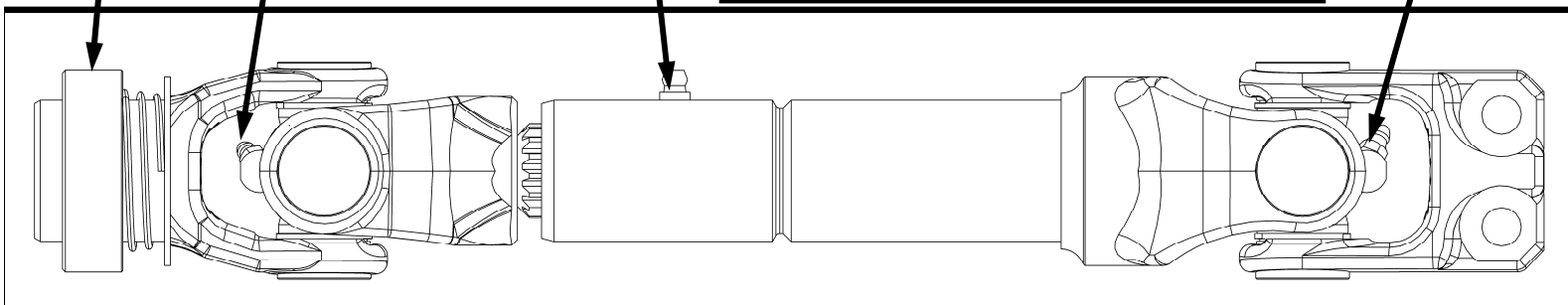

TROUBLESHOOTING

Problem	Cause	Correction
Engine Will Not Turn Over	<ol style="list-style-type: none"> 1. Control levers not in neutral position. 2. Battery is undercharged or failing. 3. Circuit breaker on engine tripped. 	<ol style="list-style-type: none"> 1. Make sure control levers are in the middle of their travel. 2. Charge or replace the battery. 3. Reset circuit breaker at engine.
Excessive Vibration	<ol style="list-style-type: none"> 1. Worn, bent or loose PTO Adapter. 2. Loose hardware on PTO shaft. 	<ol style="list-style-type: none"> 1. Replace PTO adapter; Tighten PTO adapter bolts. 2. Tighten PTO shaft bearing mounting hardware.
Loss of Power To Engine	<ol style="list-style-type: none"> 1. Faulty fuse. 2. Wire harness not fully connected. 3. Emergency Shut-off Switch engaged. 	<ol style="list-style-type: none"> 1. Replace faulty fuse. 2. Ensure wire harness is connected. 3. Ensure the shut-ff switch is disengaged.
No Power To Attachment	<ol style="list-style-type: none"> 1. Operator Control presence not activated. 2. PTO shaft not connected to PTO adapter (Tractor). 3. Bent or Damaged PTO shaft. 4. Loose or damaged belt on Attachment. 5. Loose or damaged engine-to-PTO adapter belt. 6. Loose or faulty clutch wiring harness. 7. Faulty clutch. 	<ol style="list-style-type: none"> 1. Operator must be present at the control levers if required by attachment. 2. Ensure the PTO shaft is connected to the Tractor PTO adapter. 3. Replace PTO shaft. 4. Tighten or replace gearbox-to-attachment belt. 5. Tighten or replace engine-to-PTO adapter belt. 6. Ensure clutch wiring is tight and not damaged. 7. Replace clutch.

POWER UNIT IDENTIFICATION

Power Unit Identification

Each mower has its own model number and serial number. The number for the attachment can be found on the motor base (refer to Symbols & Decal section for reference). All mower parts listed herein may be ordered directly from Swisher or your nearest Swisher dealer.

Unauthorized Replacement Parts

Use only Swisher replacement parts. The replacement of any part on this unit with anything other than a Swisher authorized replacement part may adversely affect the performance, durability and safety of this unit and may void the warranty. Swisher disclaims liability for any claims or damages, whether warranty, property damage, personal injury or death arising out of the use of unauthorized replacement parts.

WHEN ORDERING PARTS, PLEASE HAVE THE FOLLOWING INFORMATION AVAILABLE:

- MODEL NUMBER - _____
- SERIAL NUMBER - _____
- DATE PURCHASED - _____
- PURCHASE FROM - _____
- PART NUMBER (W/ PAINT CODE) - _____
- PART DESCRIPTION - _____

S.A.I.
1602 CORPORATE DRIVE
WARRENSBURG, MO 64093

www.swisherinc.com
TELEPHONE - 1-800-222-8183
FAX - 1-660-747-3160

cust.serv@swisherinc.com

REPLACEMENT PARTS

Quick Reference

Swisher Part #	Part Description
21560	Belt - V; 1/2" X 48"
20846	Belt - Wrapped, 34.5"
21513	Shaft - PTO, 6E Drive
21514	Tire/Wheel - 18 X 850-10
21556	Filter - Hydro Gear, 25 Micron
21550	Hose - 3/8" ID(SEE PARTS BREAKDOWN FOR INDIVIDUAL LENGTHS)
21547	Hose - Hyd, 1/2" X 15" (2) FMLE JIC 3/4"
AS069	Electrical - 10 Amp Fuse
21525	Collar - Pivot
H11	Pin - Safety Hitch 3/8 X 2 1/2 ZY



CAUTION

Use extreme care when working on machinery.

Before performing any maintenance, turn off engine, allow the unit to cool and remove the key. Disconnect spark plug wire.

Set Parking Brake by pushing on the brake lever until locked into the "engaged" position.

Do not wear watch or jewelry. Do not wear loose fitting clothes. Observe all common safety practices with tools.

ENGINE ASSEMBLY

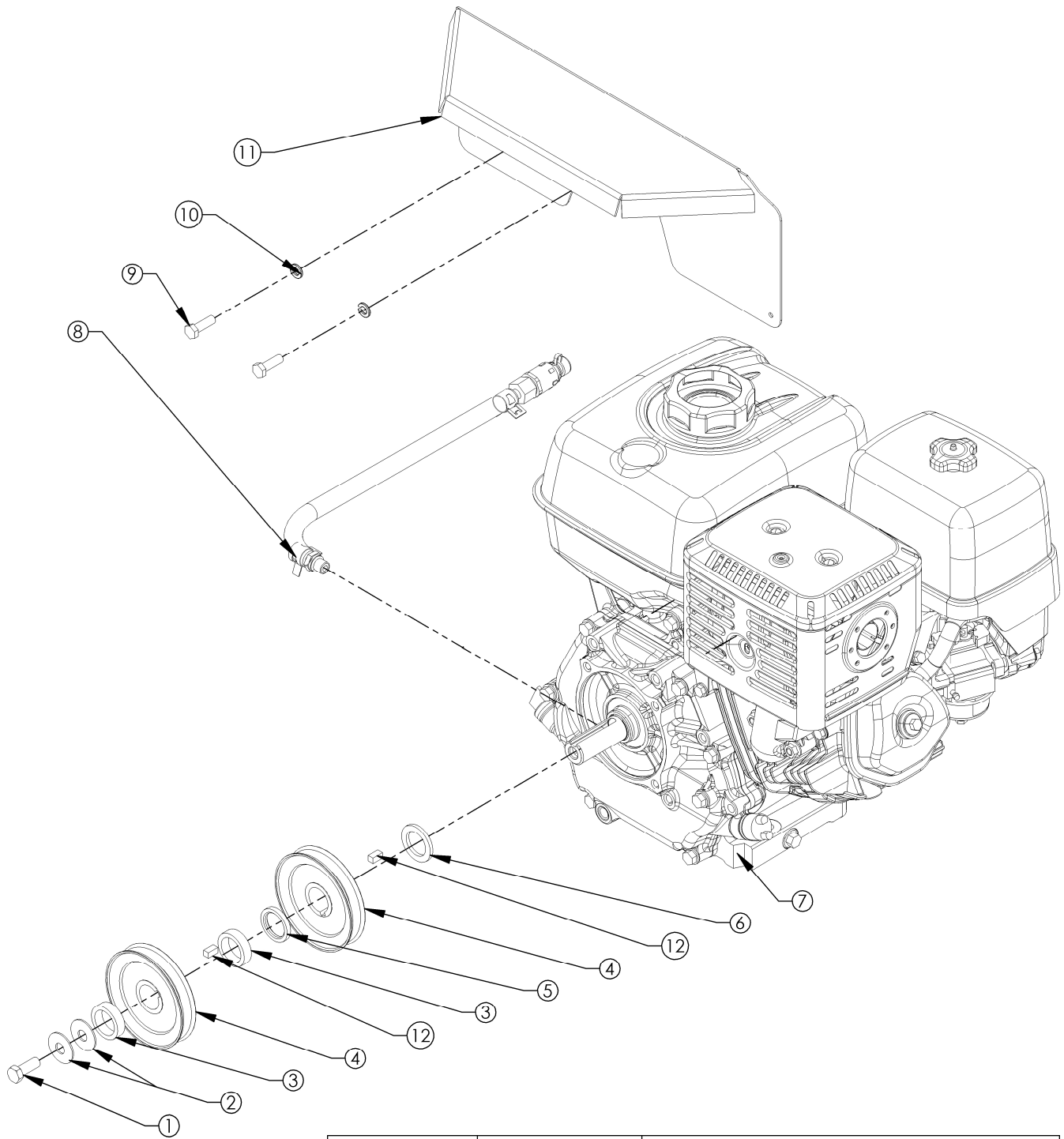

ITEM NO.	PART NUMBER	DESCRIPTION
1	NB238N	BOLT - HHC 3/8-24 X 1 GR5
2	699	WASHER - BELLEVILLE 7/16 X 1 1/4
3	21644*	SPACER - 1.010" ID X 1.375" OD X .680"
4	21559	PULLEY - 1" ID X 4" OD A
5	16834	SPACER - 1.00" CRANKSHAFT, CLUTCH
6	NB614	WASHER - 1 X 1 1/2 10GA HARDENED
7	21519	ENGINE - HONDA OHV 389CC HORIZ, 1" SHAFT
8	21713	ASSEMBLY - OIL DRAIN
9	NB451	BOLT - 5/16-24 X 1 HCF GR5
10	NB159	WASHER - SPLIT LOCK 5/16
11	21669*	COVER - BELT, TOP
NOT SHOWN	21561	ASSEMBLY - REMOTE CHOKE
12	4258	KEY STOCK - 1/4 X 1/2 UNDER SZ CRBN STL

When Ordering Replacement Parts:

* = USE PAINT CODE: TK=BLACK

PUMP / PUMP MOUNT ASSEMBLY

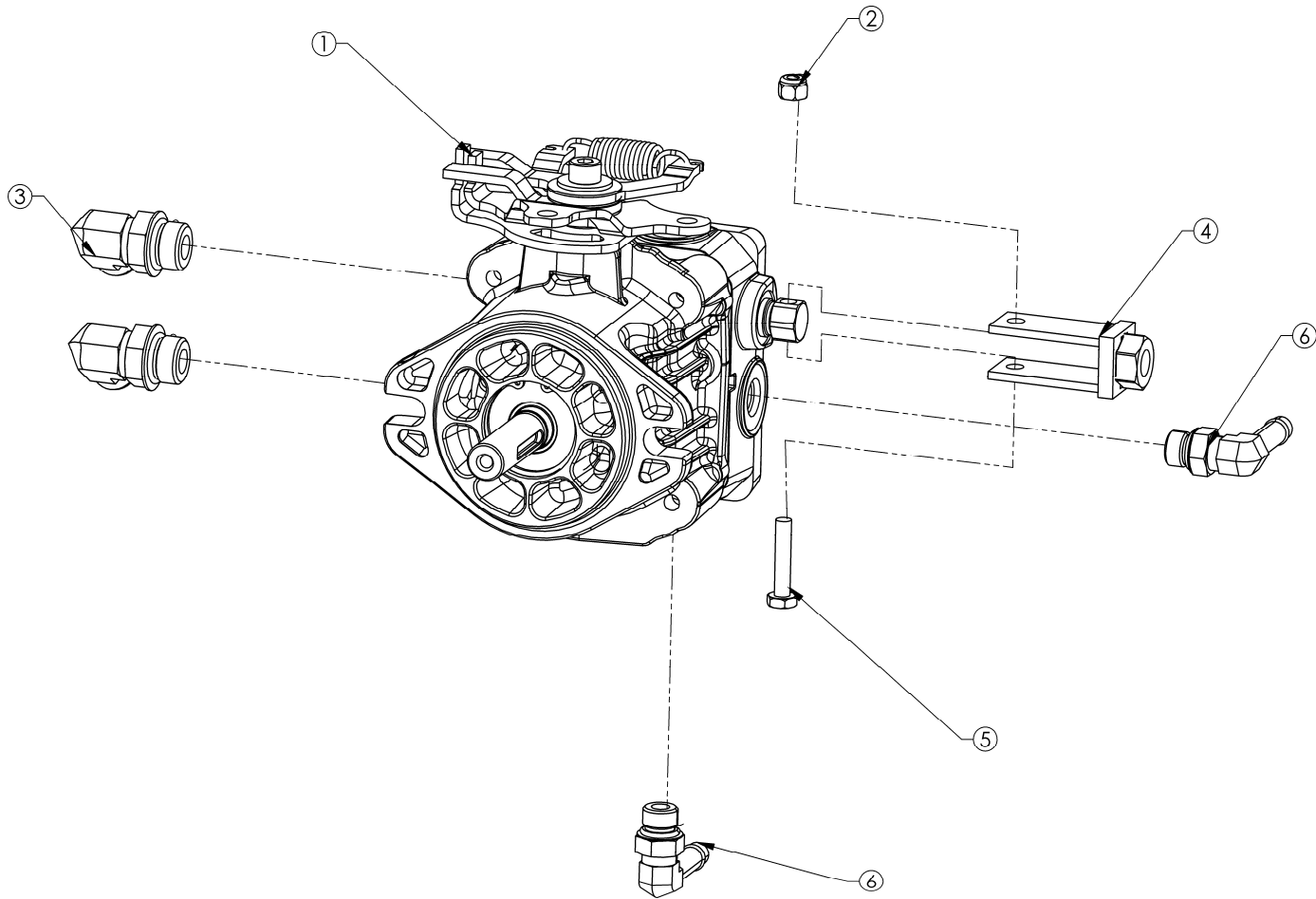

ITEM NO.	PART NUMBER	DESCRIPTION
1	21517 / 21518	PUMP - HYD. , 10CC , (LEFT OR RIGHT)
2	NB180	1/4-20 NYLOK NUT
3	21545	FITTING - HYD , 90° MALE , JIC 3/4-16 X SAE-ORB 3/4-16
4	21725*	WELDMENT - BYPASS
5	NB560	BOLT - 1/4-20 X 1 1/4 HCC GR5
6	21548	ADAPTER - HYDRAULIC, 4601-06-06

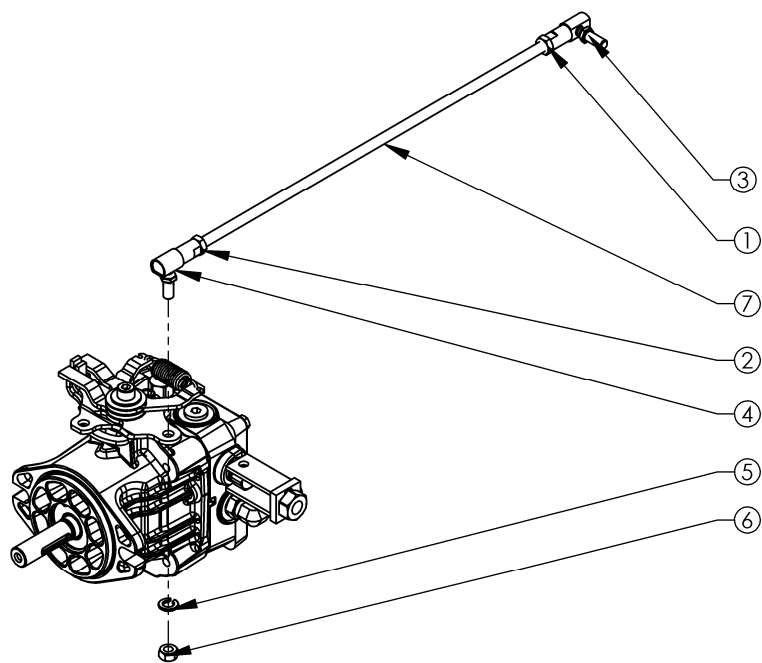

ITEM NO.	PART NUMBER	DESCRIPTION
1	NB265	NUT - JAM, 5/16"-24 ZY GRD 2
2	NB190	NUT - JAM, 5/16"-24 ZY GRD 2
3	NB263	BALL LINKAGE RIGHT (SILVER)
4	NB264	BALL LINKAGE - LH THREAD
5	NB159	WASHER - SPLIT LOCK 5/16 ZY
6	NB215	NUT - HEX 5/16-24 GR2 ZY
7	21526	LINKAGE - 16.5" X 5/16-24 X 1" LHT & 5/16-24 X 1" RHT

When Ordering Replacement Parts:

* = USE PAINT CODE: TK=BLACK

PUMP / PUMP MOUNT ASSEMBLY

SEE CLUTCH STOP DETAIL BELOW

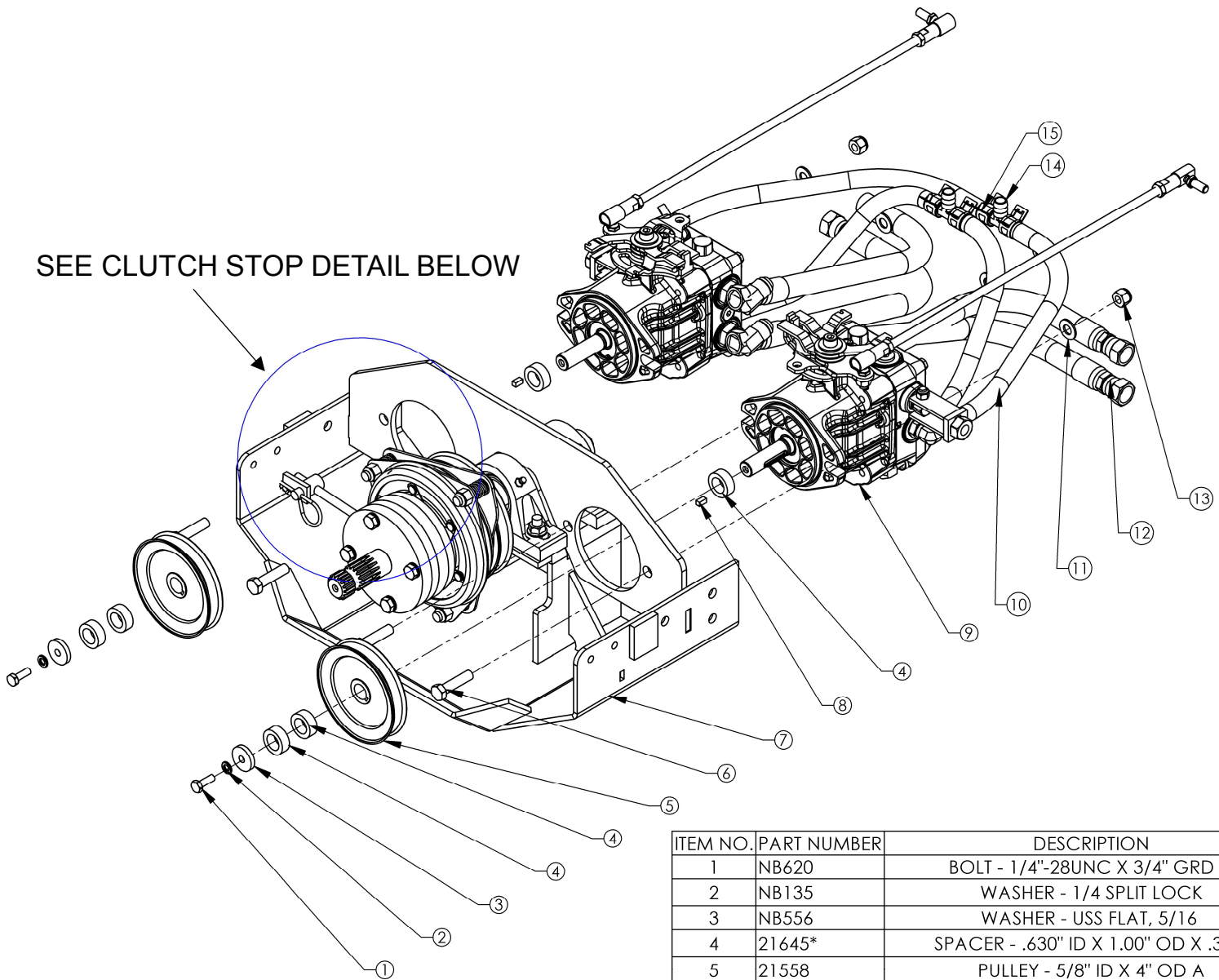

ITEM NO.	PART NUMBER	DESCRIPTION
1	NB620	BOLT - 1/4"-28UNC X 3/4" GRD 5
2	NB135	WASHER - 1/4 SPLIT LOCK
3	NB556	WASHER - USS FLAT, 5/16
4	21645*	SPACER - .630" ID X 1.00" OD X .375"
5	21558	PULLEY - 5/8" ID X 4" OD A
6	NB107	BOLT - 3/8-16 X 1 1/2 HCC GR5
7	21578*	WELDMENT - PUMP MOUNT
8	12473	KEY STOCK - 3/16 SQ X 3/8, UNDERSIZED
9	21517 / 21518	PUMP - HYD. , 10CC , (LEFT OR RIGHT)
10	21565	CLAMP - HOSE, 17mm
11	NB272	WASHER - SAE FLAT 3/8
12	21547	HOSE - HYD. , 1/2" X 15" , (2) FMLE JIC
13	NB182	NUT - NYLOC 3/8-16
14	21549	ADAPTER - HYDRAULIC, BRASS T 3/8"
15	21565	CLAMP - HOSE, 17mm

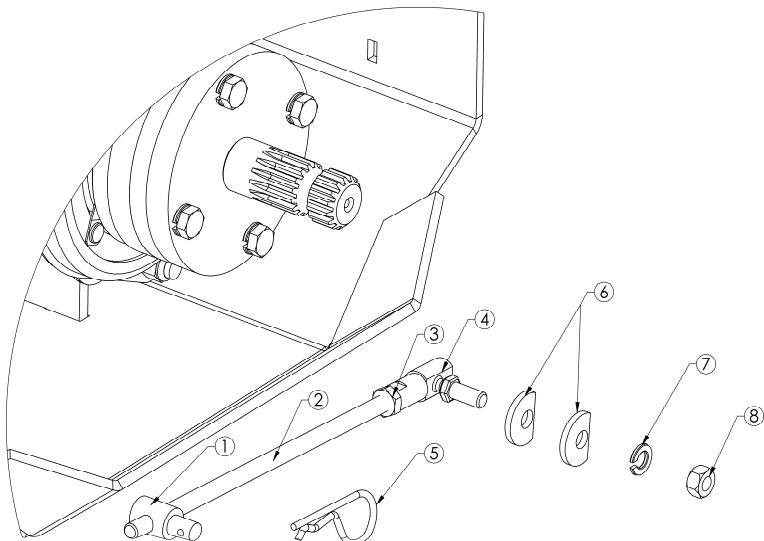

CLUTCH STOP ASSEMBLY

ITEM NO.	PART NUMBER	DESCRIPTION
1	14028	CONNECTOR
2	21533	ROD - 5/16"-24 X 8.25"
3	NB190	NUT - JAM 5/16-24 ZY GRADE 2
4	NB263	LINKAGE - BALL, RIGHT; MORIDGE# 265615
5	NB247	PIN - HAIR COTTER #4
6	22384Z	WASHER - 11GA X .344"ID X 1.00"OD ; ZP
7	NB159	WASHER - SPLIT LOCK 5/16
8	NB215	NUT - HEX 5/16-24 ZY GRADE 2
1-4	21754	ASSEMBLY - CLUTCH STOP

When Ordering Replacement Parts:

SHAFT / CLUTCH ASSEMBLY

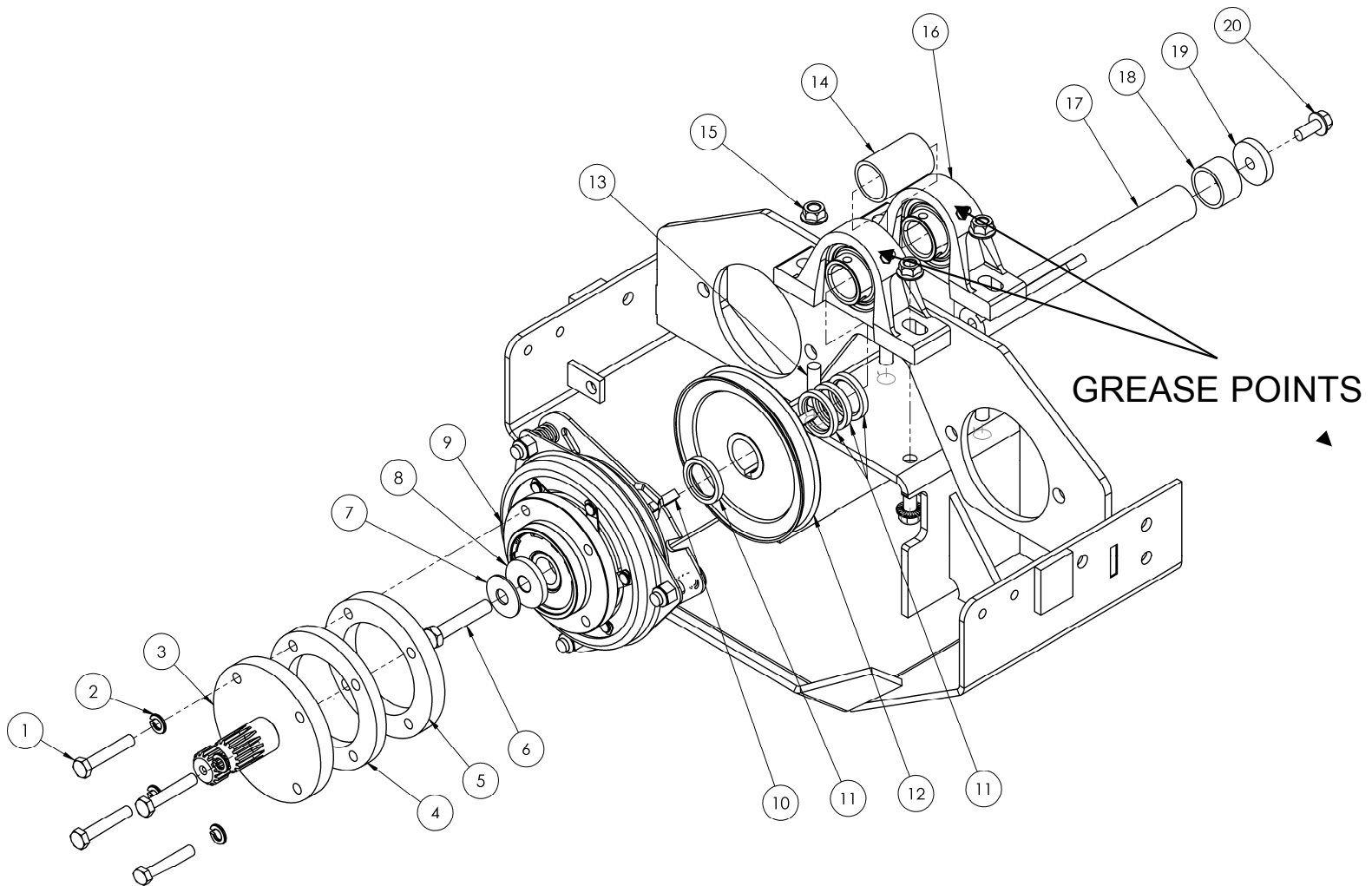

ITEM NO.	PART NUMBER	DESCRIPTION
1	21529	BOLT - M8-1.25 X 45mm
2	NB159	WASHER - SPLIT LOCK 5/16
3	21581*	WELDMENT - SPLINE ADAPTER
4	21627*	PLATE - PTO ADAPTER , 3/8"
5	21626*	PLATE - PTO ADAPTER
6	20777	BOLT - HEX 3/8-24 X 2, GR8
7	699	WASHER - BELLEVILLE 7/16 X 1 1/4
8	18631	BUSHING - CLUTCH
9	21521	CLUTCH - ELECTRIC , HORIZONTAL 90FT LBS
10	9031	KEY STOCK - 1/4 X 1 UNDER SZ
11	16834	SPACER - 1.00" CRANKSHAFT, CLUTCH
12	21563	PULLEY - 1" ID X 5" OD A
13	21762	BOLT - SERR FLANGE, ZY 3/8-16X1/2 GR5
14	21643*	SPACER - 1.030" ID X 1.250" OD X .1.572"
15	NB779	NUT - SERR FLANGE, HEX ZY 3/8-16
16	21539	BEARING - PILLOW BLOCK
17	21522	SHAFT - ADAPTER , CLUTCH
18	21642*	SPACER - 1.030" ID X 1.250" OD X .1.250"
19	21718*	PLATE - WASHER
20	NB596	BOLT - 5/16" X 18 UNC X .75" FLANGE HEAD

When Ordering Replacement Parts:

* = USE PAINT CODE: TK=BLACK

IDLER ASSEMBLIES

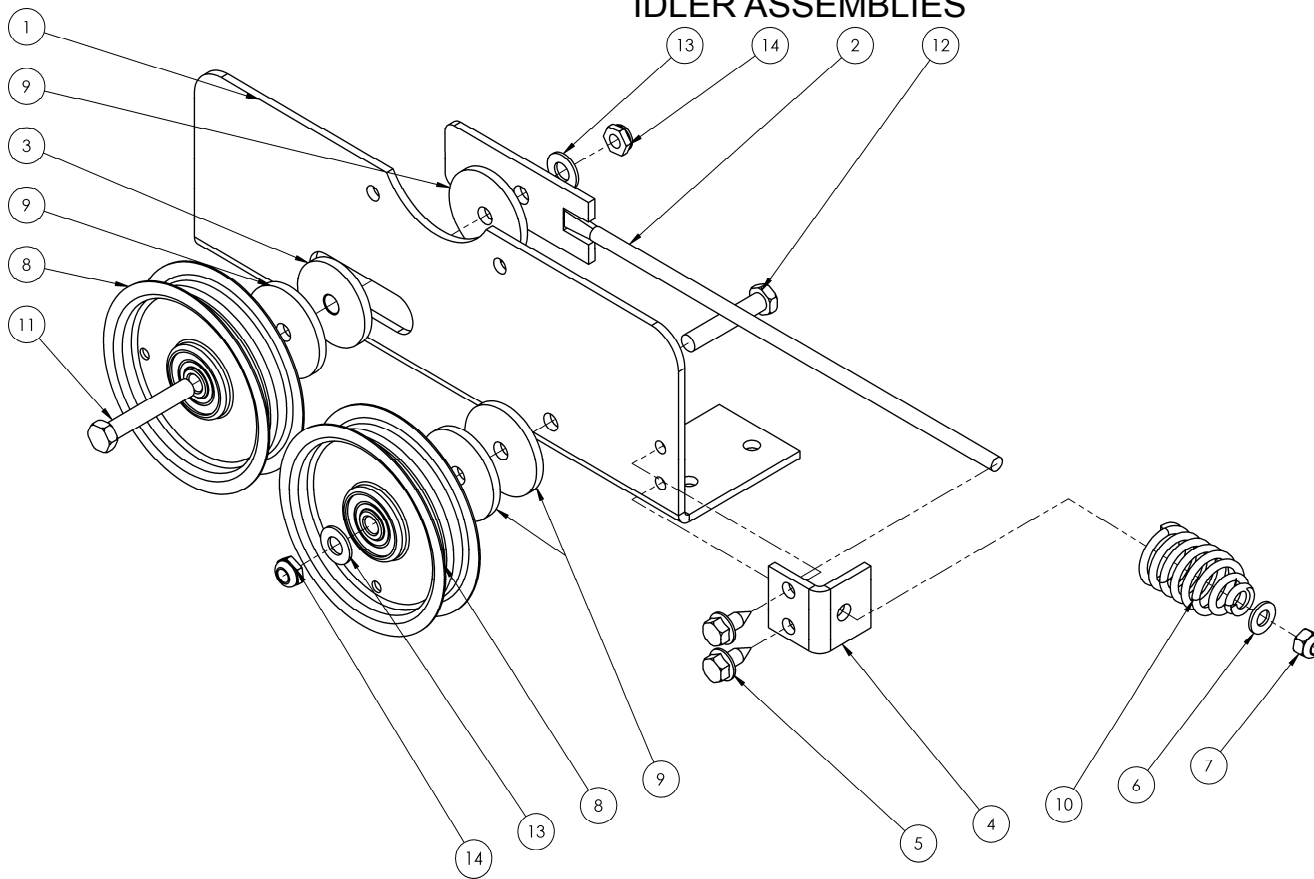

ITEM NO.	PART NUMBER	DESCRIPTION
1	21606*	PLATE - IDLER , DRIVE BELT
2	21610*	WELDMENT - DRIVE IDLER
3	6037	BUSHING - IDLER
4	21608*	PLATE - IDLER , TENSION
5	26X249	SCREW - .312-18 X .75 BLACK ZINC
6	NB275	WASHER - SAE FLAT 5/16
7	NB181	NUT - NYLOC 5/16-18
8	14424	PULLEY-BACKSIDE IDLER
9	6040Z	WASHER - IDLER
10	3609	SPRING - TAPERED
11	NB693	BOLT - HTC, 3/8-16 X 2 1/4 GR5
12	NB198	BOLT - 3/8-16 X 2 HCC GR5
13	NB272	WASHER - SAE FLAT 3/8
14	NB207	NUT - 3/8-16 NYLOC JAM

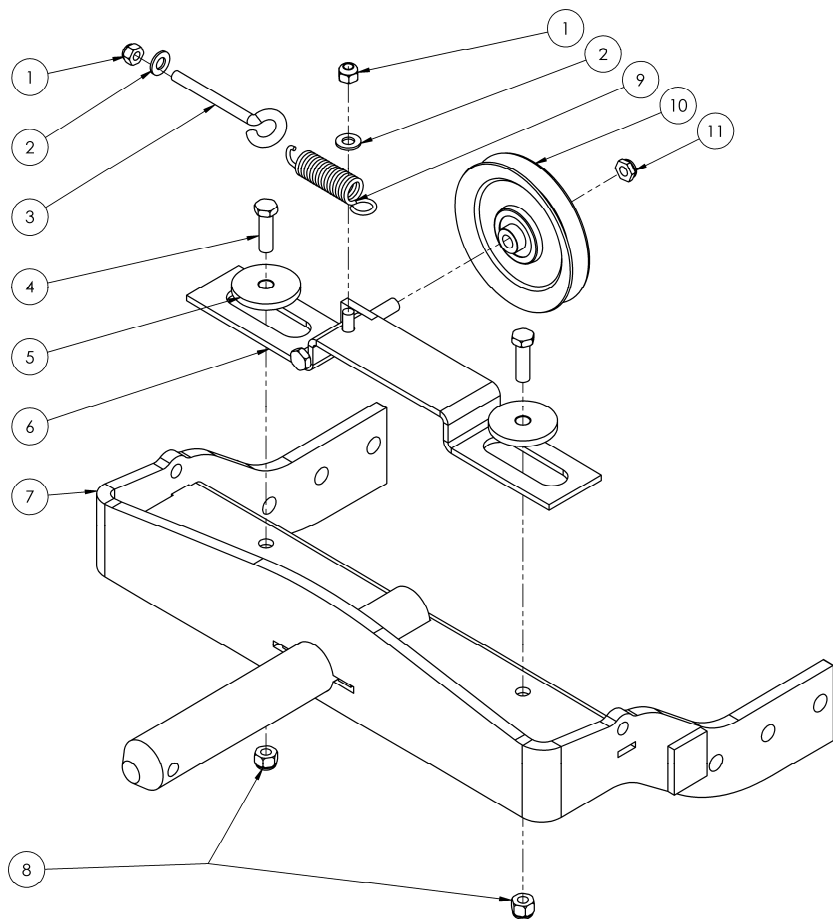

ITEM NO.	PART NUMBER	DESCRIPTION
1	NB181	NUT - NYLOC 5/16-18
2	NB275	WASHER - SAE FLAT 5/16
3	NB315	EYEBOLT - 5/16-18 X 3 W/GAP
4	NB618	BOLT - 3/8-16 X 1 1/4 GR5
5	6037	BUSHING - IDLER
6	21675*	WELDMENT - IDLER , PTO
7	21577*	WELDMENT - PIVOT ASSEMBLY
8	NB182	NUT - NYLOC 3/8-16
9	7821	SPRING - LATCH
10	21564	PULLEY - V , IDLER 3/8" ID X 4.5" OD A
11	NB207	NUT - 3/8-16 NYLOC JAM
12	NB170	NUT - 5/16-18 SERR FLANGE

When Ordering Replacement Parts:

* = USE PAINT CODE: TK=BLACK

WHEEL MOTORS

ITEM NO.	PART NUMBER	DESCRIPTION
1	21511 / 21512	MOTOR - WHEEL , HYD , (LEFT OR RIGHT)
2	NB604	BOLT - 3/8-16 X 1 GR5
3	21641*	PLATE - ADAPTER , WHEEL MOTOR
4	NB281	NUT - NYLOC 1/2-13
5	21546	FITTING - HYD. 90° MALE 3/4"X16 JIC X 7/8"-14 ORB
6	NB510	BOLT - 1/2-13 X 2 1/2 HCC GR5
7	21628*	PLATE - MB SIDE
8	NB182	NUT - NYLOC 3/8-16

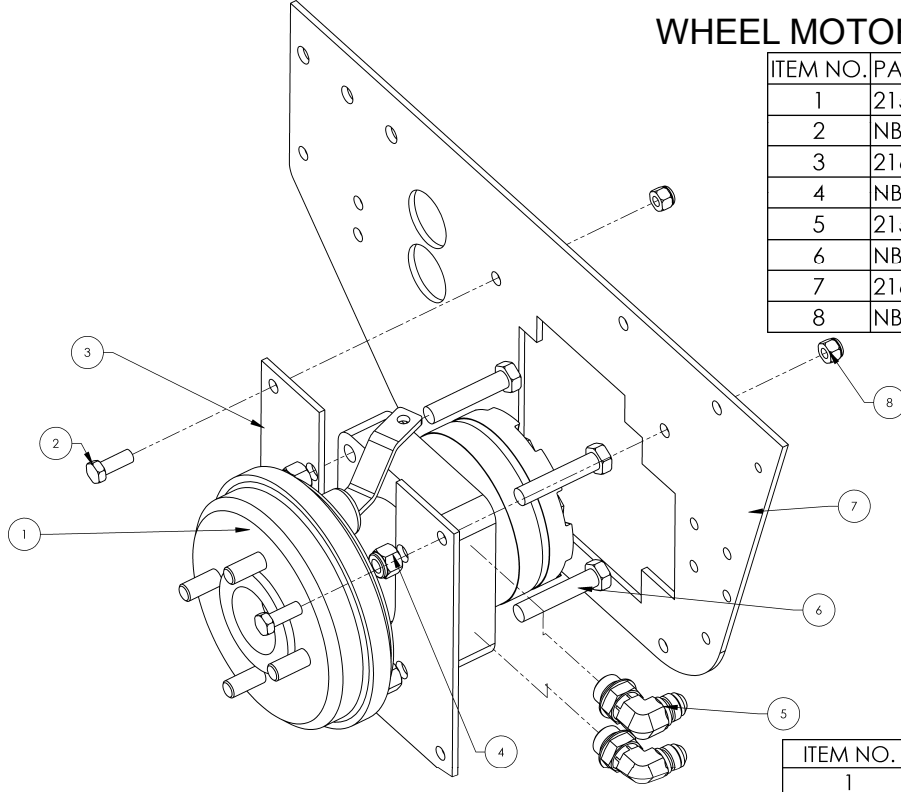

LOWER MOTOR BASE

ITEM NO.	PART NUMBER	DESCRIPTION
1	21752	WELDMENT - SULKY , HITCH
2	NB182	NUT - NYLOC 3/8-16
3	21654*	PLATE - SKID
4	NB604	BOLT - 3/8-16 X 1 GR5
5	NB170	NUT - 5/16-18 SERR FLANGE
6	NB253	BOLT - SERR FLG 5/16-18 X 1 1/4
7	TZ2S	SPRING - EXTENSION 4.25 C/C, 40 COILS
8	21724*	WELDMENT - BRAKE
9	NB632	PIN - SNAP Ø3/8 X 1 3/8 USABLE
10	21723*	WELDMENT - BRAKE , PIVOT
11	26X249	SCREW - .312-18 X .75 BLACK ZINC
12	NB107	BOLT - 3/8-16 X 1 1/2 HCC GR5
13	NB618	BOLT - 3/8-16 X 1 1/4 GR5

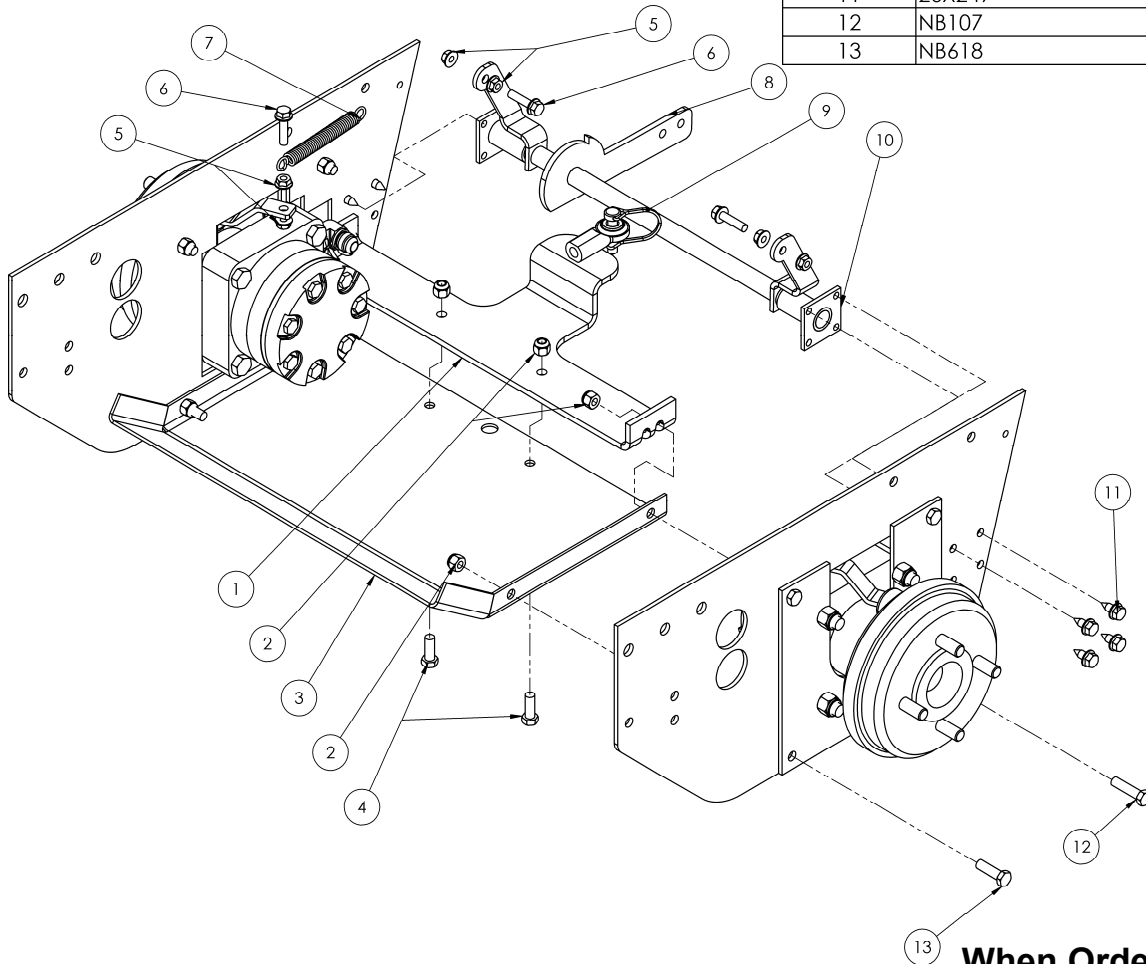

When Ordering Replacement Parts:

UPPER MOTOR BASE

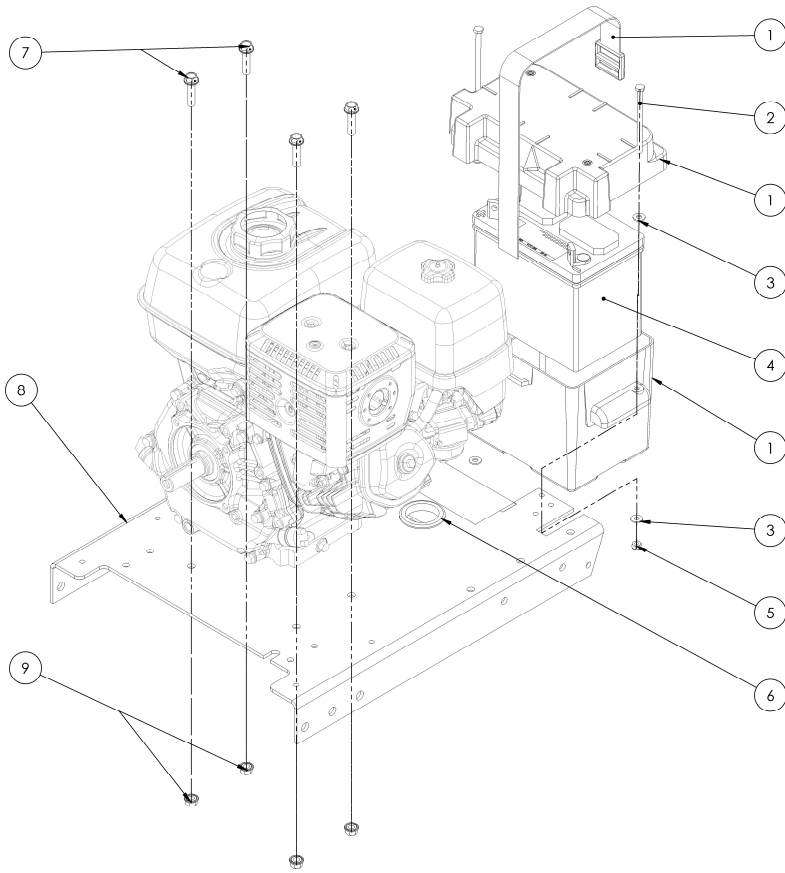

ITEM NO.	PART NUMBER	DESCRIPTION
1	19974	BATTERY - BOX
2	NB551	BOLT - 1/4-20 X 4 HTC GR2
3	NB274	WASHER - SAE FLAT 1/4
4	N/A	UL1 TYPE BATTERY 340 CC
5	NB180	NUT - NYLOC 1/4-20
6	12441	GROMMET - PVC 1.75"ID X 2.375"OD, 2"GD 11GA
7	21762	BOLT - SERR FLANGE, ZY 3/8-16X1/2 GR5
8	21612*	WELDMENT - MOTOR BASE , WB
9	NB779	NUT - SERR FLANGE, HEX 3/8-16

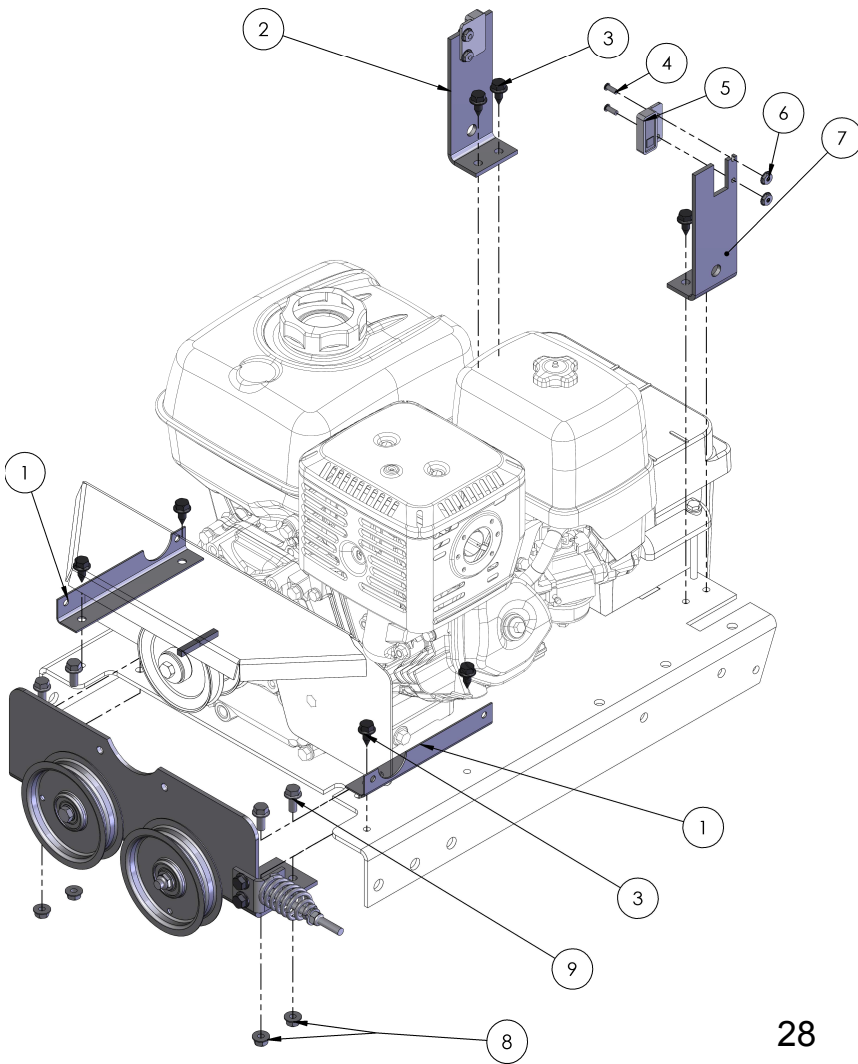

ITEM NO.	PART NUMBER	DESCRIPTION
1	21671*	BRACKET - MOUNTING, GUARD
2	21767*	PLATE - PIVOT SUPPORT ; RIGHT
3	26X249	SCREW - .312-18 X .75 BLACK ZINC
4	NB197	SCREW - PHILLIPS TRUSS 8-32 X 1/2
5	21573	SWITCH - PROXIMITY
6	NB201	NUT - KEP 8-32
7	21657*	PLATE - PIVOT SUPPORT ; LEFT
8	NB170	NUT - 5/16-18 SERR FLANGE
9	NB596	BOLT - 5/16" X 18 UNC X .75" FLANGE HEAD

When Ordering Replacement Parts:

* = USE PAINT CODE: TK=BLACK

CONTROLS / CONTROL TOWER

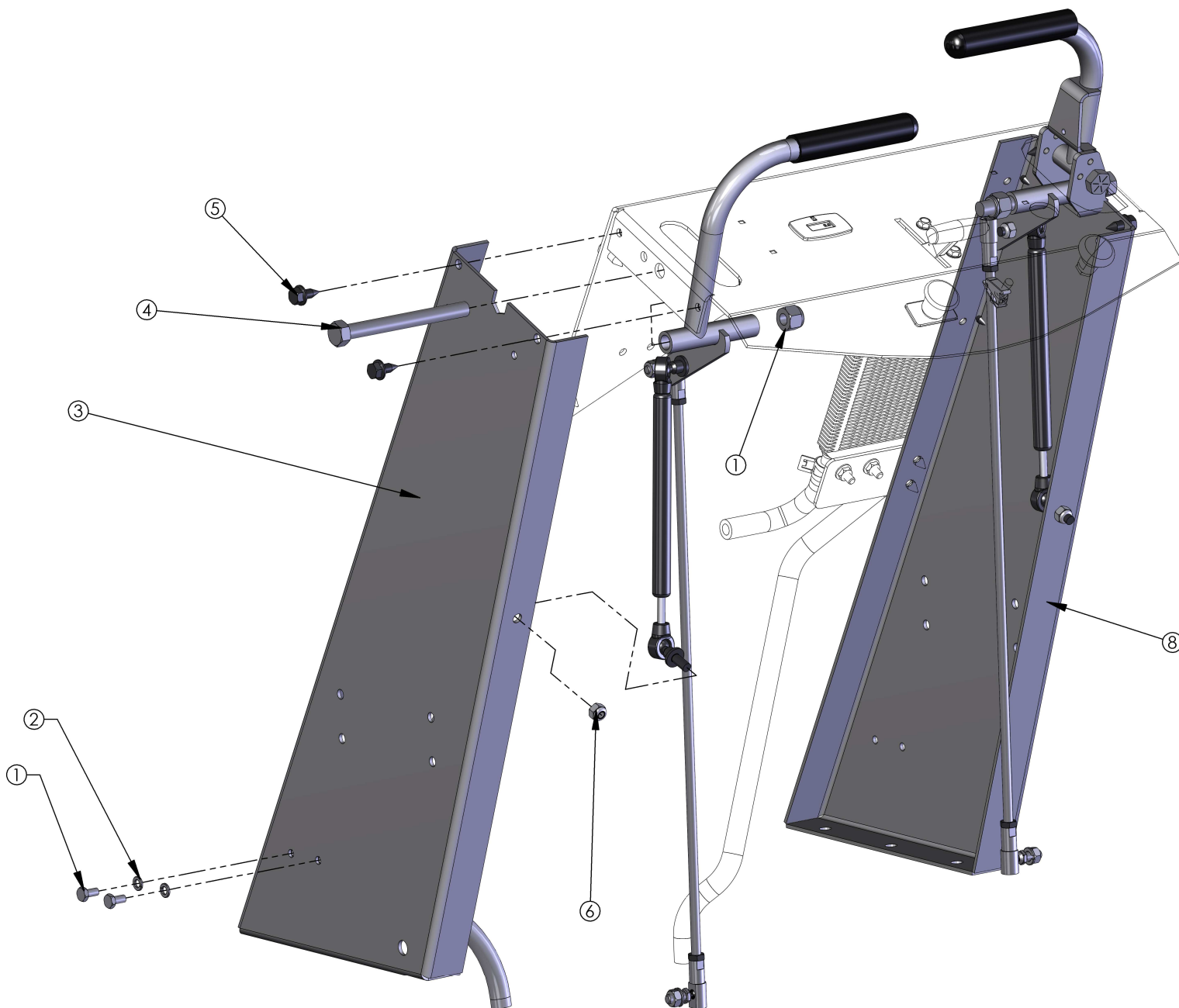

ITEM NO.	PART NUMBER	DESCRIPTION
1	NB134	BOLT - 1/4-20 X 1/2 HCC GR5
2	NB135	WASHER - 1/4 SPLIT LOCK
3	21716*	WELDMENT - CONTROL TOWER , LEFT
4	NB155	BOLT - 1/2-13 X 5 HCC GR5
5	26X249	SCREW - .312-18 X .75 BLACK ZINC
6	NB181	NUT - NYLOC 5/16-18
7	NB281	NUT - NYLOC 1/2-13
8	21715*	WELDMENT - CONTROL TOWER , RIGHT

When Ordering Replacement Parts:

* = USE PAINT CODE: TK=BLACK

CONTROLS / CONTROL TOWER

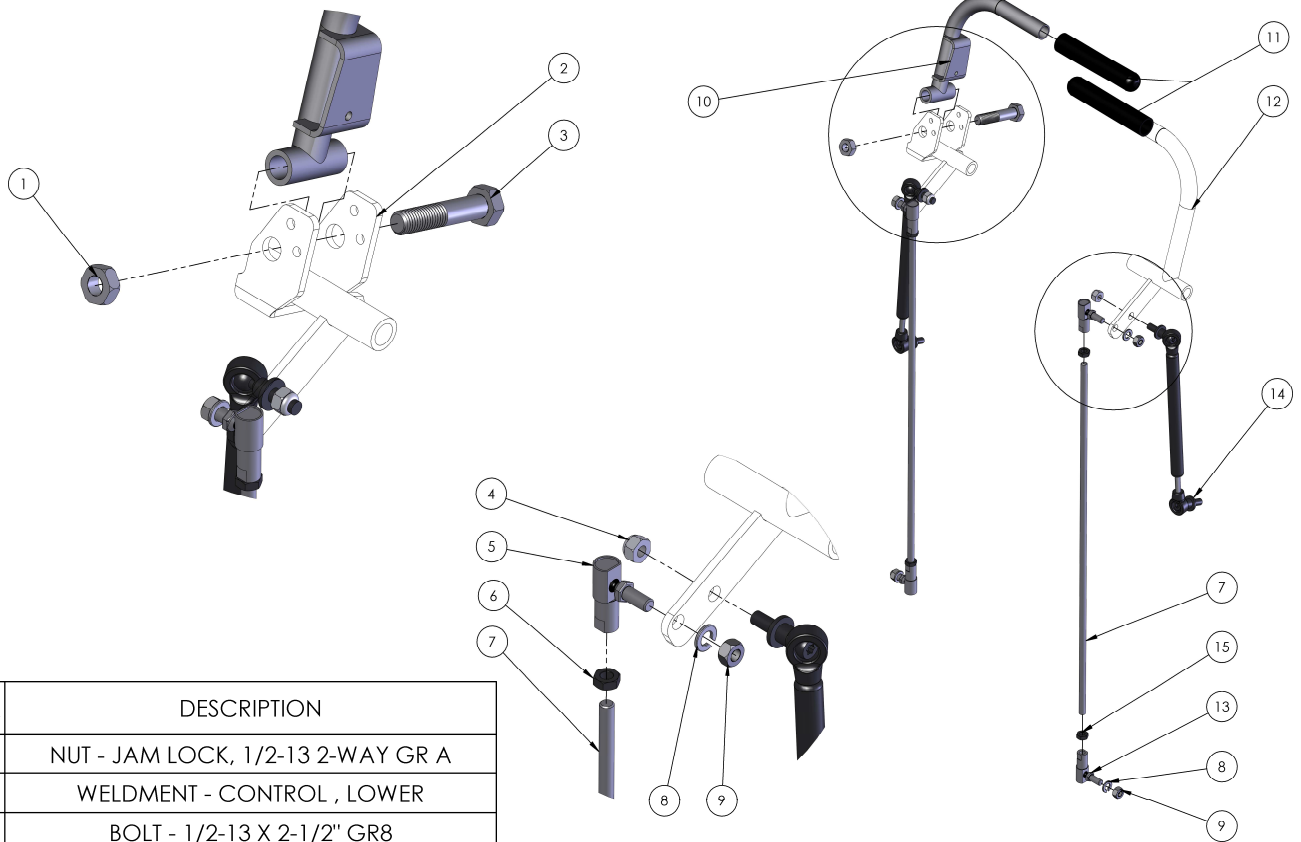

ITEM NO.	PART NUMBER	DESCRIPTION
1	NB121	NUT - JAM LOCK, 1/2-13 2-WAY GR A
2	21660*	WELDMENT - CONTROL , LOWER
3	20570	BOLT - 1/2-13 X 2-1/2" GR8
4	NB181	NUT - NYLOC 5/16-18
5	NB264	LINKAGE - BALL, LEFT
6	NB265	NUT - JAM, 5/16"-24 ZY GRD 2
7	18627	LINKAGE - 5/16-24 X 1" LHT & 5/16-24 X 1" RHT
8	NB159	WASHER - SPLIT LOCK 5/16
9	NB215	NUT - HEX 5/16-24 GR2
10	21662*	WELDMENT - CONTROL , RIGHT
11	2427	GRIP - LEVER
12	21750	WELDMENT - CONTROL , LEFT
13	NB263	LINKAGE - BALL, RIGHT
14	18723	DAMPER - CONTROL
15	NB190	NUT - JAM, 5/16"-24 GRD 2

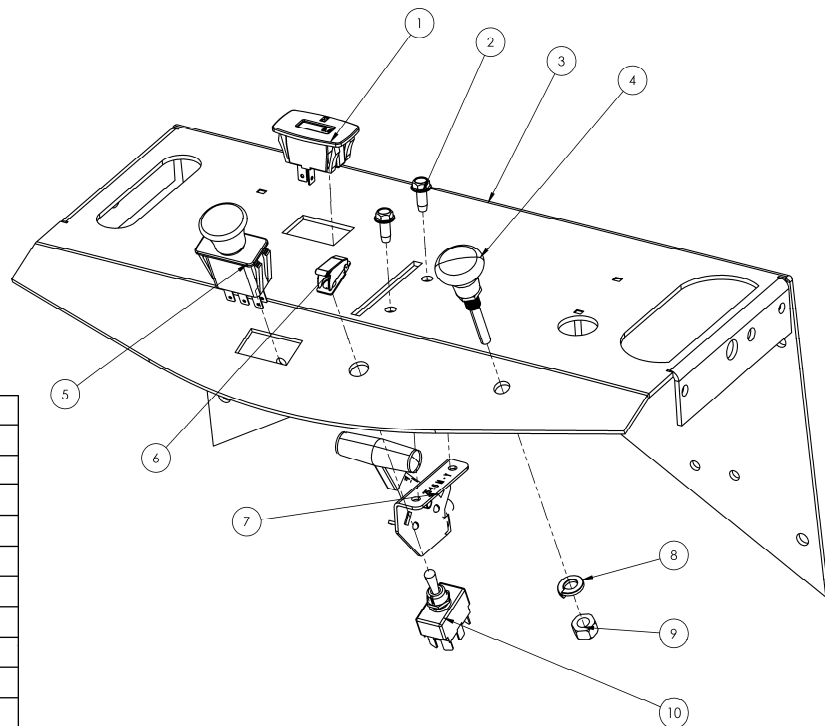

ITEM NO.	PART NUMBER	DESCRIPTION
1	17635	HOUR METER - LCD
2	26X263	SCREW - TCS 1/4-20 X 5/8
3	21663*	WELDMENT - CONTROL CONSOLE
4	21543	CABLE - CHOKE, 36"
5	3605	SWITCH - PTO
6	21751	COVER - TOGGLE SWITCH
7	21668	CABLE - THROTTLE, 34"
8	NB711	WASHER - SPLIT LOCK, 3/8" MEDIUM
9	NB456	NUT - 3/8-24 HNF GR 2
10	19192	SWITCH - TOGGLE

When Ordering Replacement Parts:

* = USE PAINT CODE: TK=BLACK

CONTROLS / CONTROL TOWER

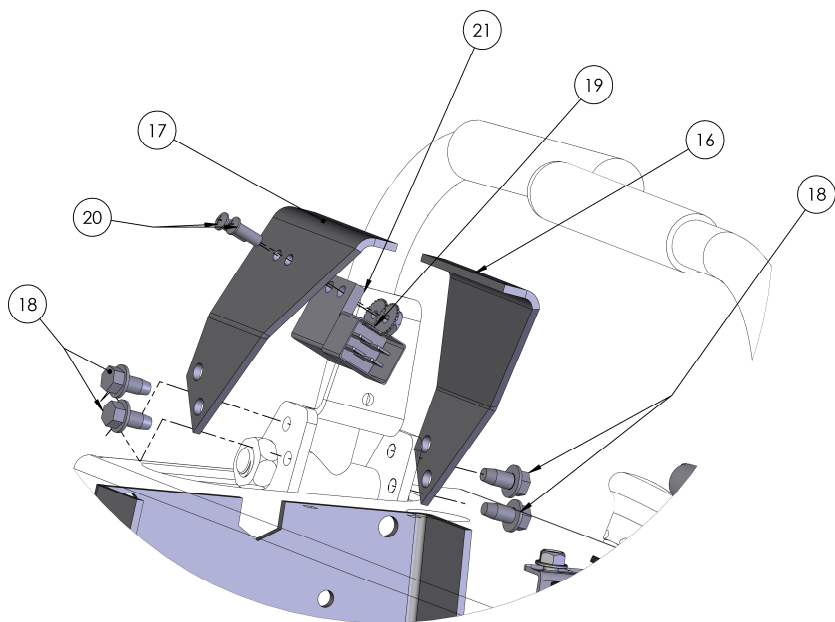
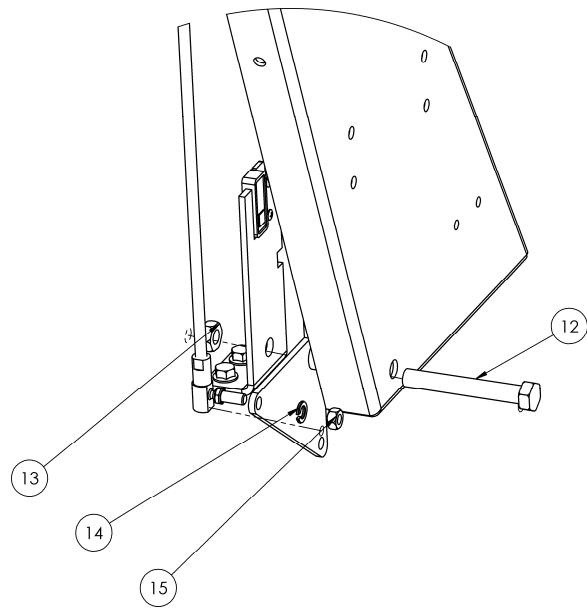
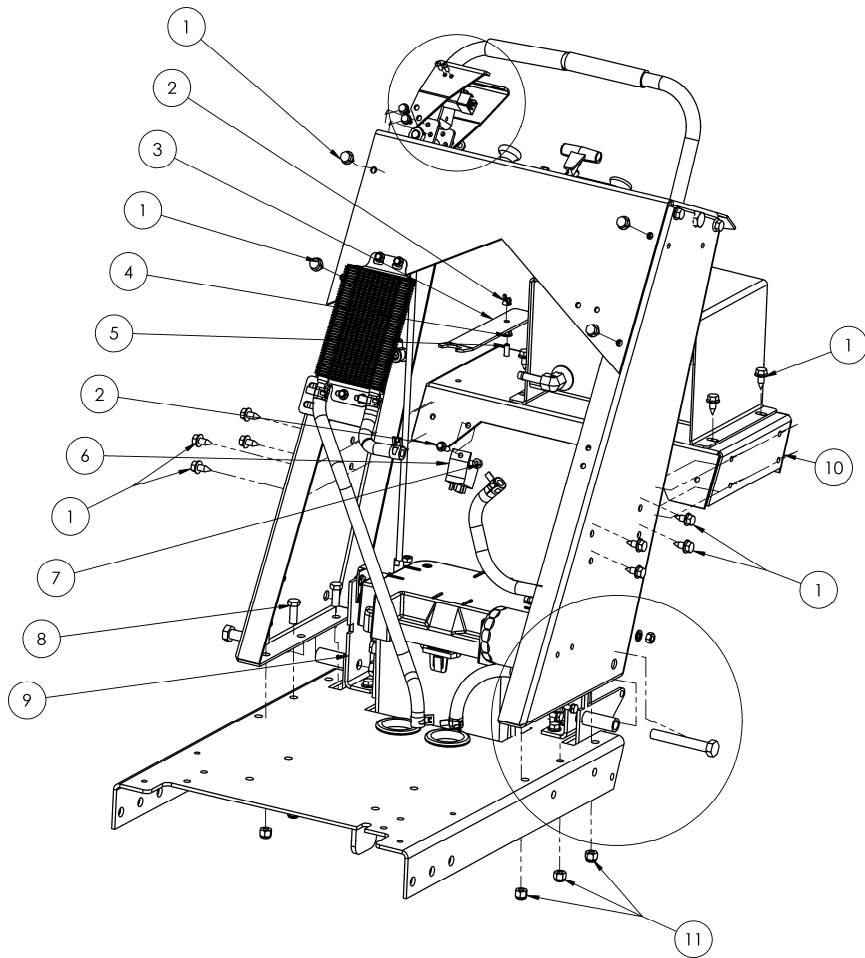

ITEM NO.	PART NUMBER	DESCRIPTION
1	26X249	SCREW - .312-18 X .75 BLACK ZINC
2	NB608	NUT - WING 1/4-20
3	21714	PLATE - BYPASS WRENCH
4	NB524	NUT - SERR FLANGE, 1/4-20 GRADE 5
5	NB690	BOLT - SERR FLANGE, 1/4-20 X 3/4 GR5
6	15749	ELECTRICAL - 12V 30 AMP RELAY
7	NB180	NUT - NYLOC 1/4-20
8	NB604	BOLT - 3/8-16 X 1 GR5
9	21656	WELDMENT - CONTROL ROD PIVOT , RIGHT
10	21632*	PLATE - COSOLE SUPPORT
11	NB182	NUT - NYLOC 3/8-16
12	NB577	BOLT - 1/2-13 X 3 1/2 GR5
13	NB121	NUT - JAM LOCK, 1/2-13 2-WAY GR A
14	NB159	WASHER - SPLIT LOCK 5/16
15	NB215	NUT - HEX 5/16-24 GR2
16	21709*	PLATE - CONTROL COVER , RIGHT
17	21708*	PLATE - CONTROL COVER , LEFT
18	NB114	BOLT - TCS 1/4-20 X 1/2 GR2
19	NB201	NUT - KEP 8-32
20	NB197	SCREW - PHILLIPS TRUSS 8-32 X 1/2
21	21567	SWITCH - DP/NO/NC

When Ordering Replacement Parts:

* = USE PAINT CODE: TK=BLACK

CONTROLS / CONTROL TOWER

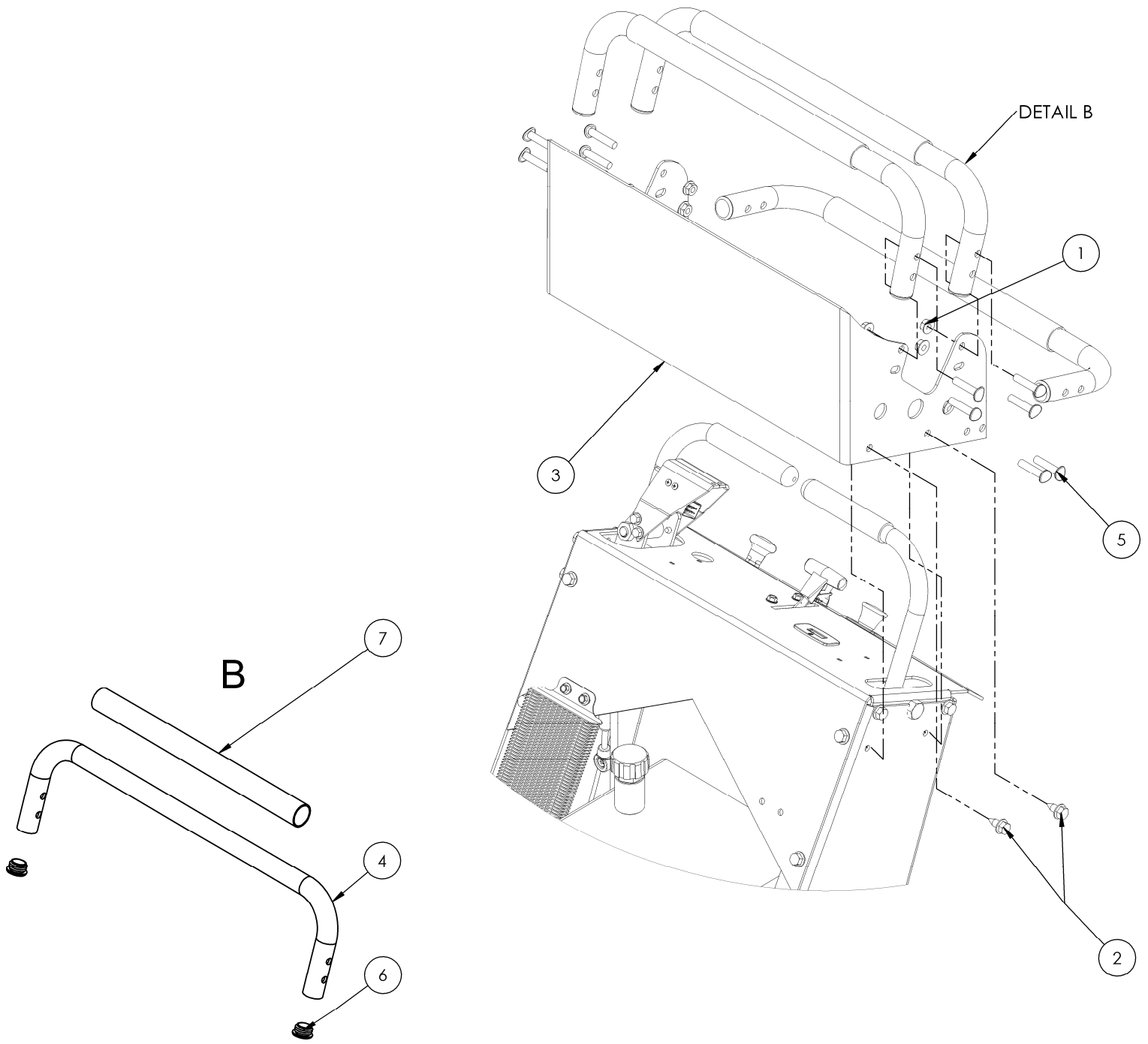

ITEM NO.	PART NUMBER	DESCRIPTION
1	NB170	NUT - SERR FLANGE 5/16-18
2	26X249	SCREW - .312-18 X .75 BLACK ZINC
3	21658*	PLATE - HAND GUARD
4	21536*	TUBE - 1" OD, CONTROL
5	21528	BOLT - CURVED HEAD , 5/16-18 X 1 1/2
6	19784	PLUG, 1" TUBE 14-20GA
7	21719	GRIP - HANDLE

When Ordering Replacement Parts:

* = USE PAINT CODE: TK=BLACK

OIL COOLER

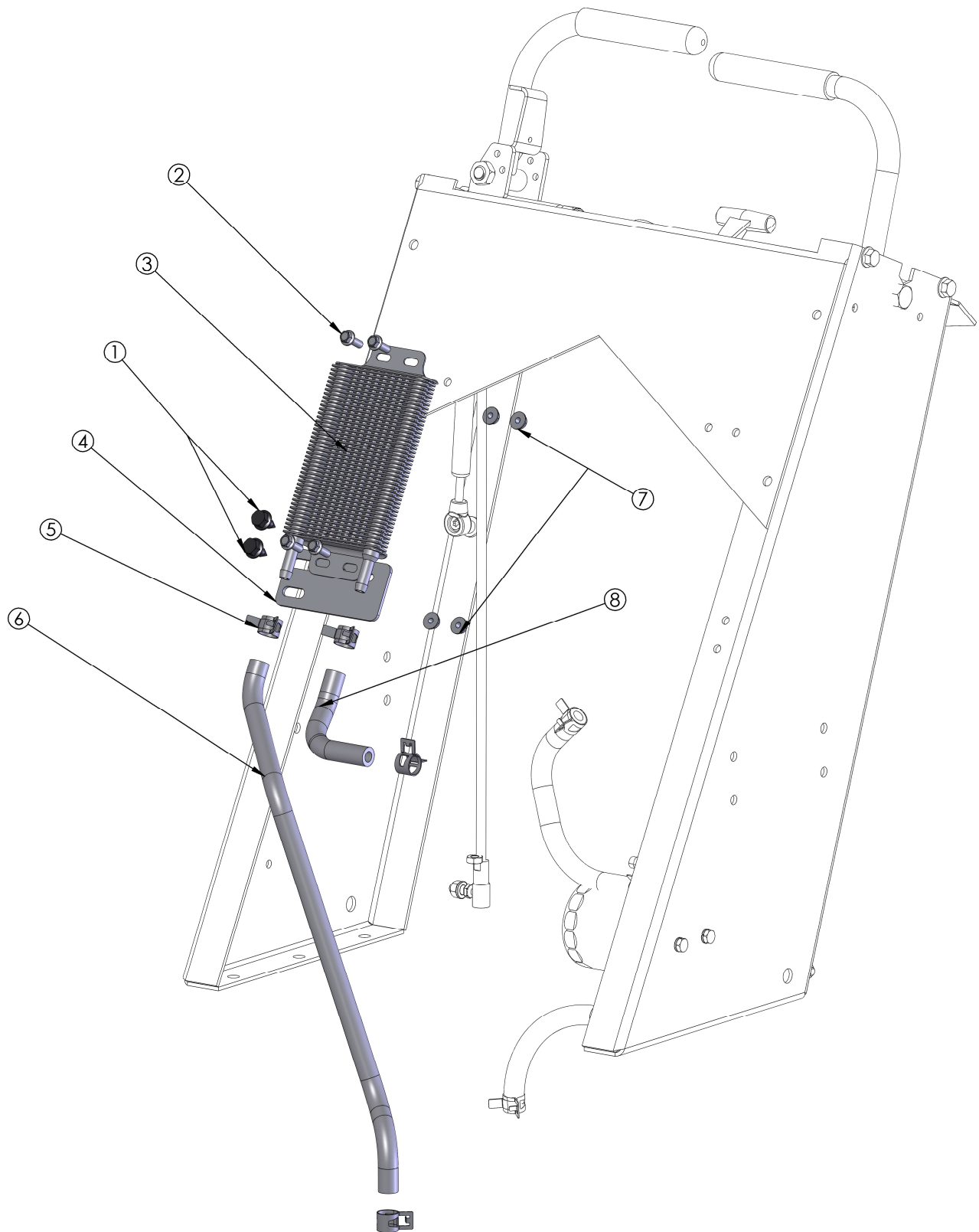

ITEM NO.	PART NUMBER	DESCRIPTION
1	26X249	SCREW - .312-18 X .75 BLACK ZINC
2	NB690	BOLT - SERR FLANGE, 1/4-20 X 3/4 GR5
3	21784	COOLER - OIL, 4 X 6
4	21787	PLATE - SUPPORT, COOLER
5	21565	CLAMP - HOSE, 17mm
6	21550	HOSE - 3/8" ID_23"
7	NB524	NUT - SERR FLANGE, 1/4-20 GRADE 5 ZY
8	21550	HOSE - 3/8" ID_6.25"

When Ordering Replacement Parts:

* = USE PAINT CODE: TK=BLACK

MAIN ASSEMBLY

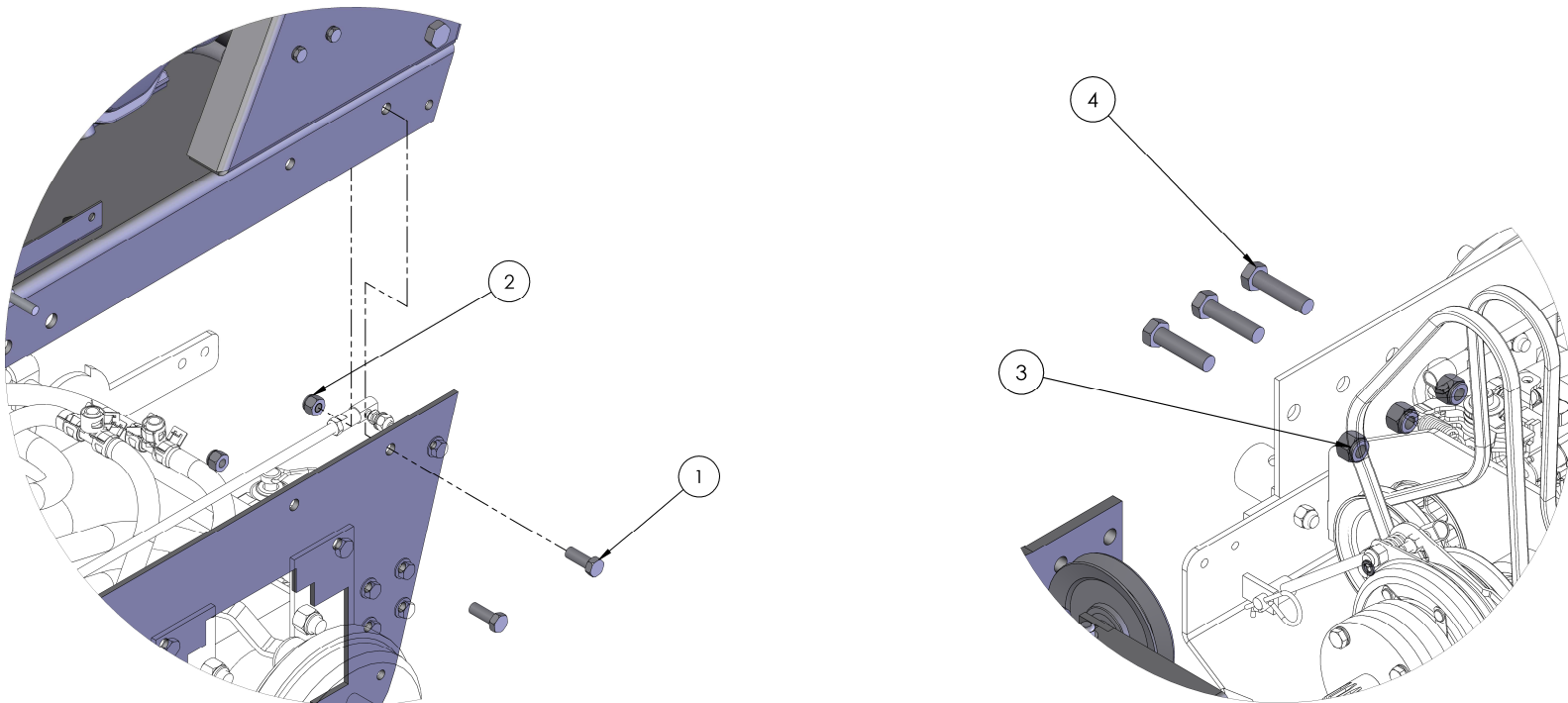
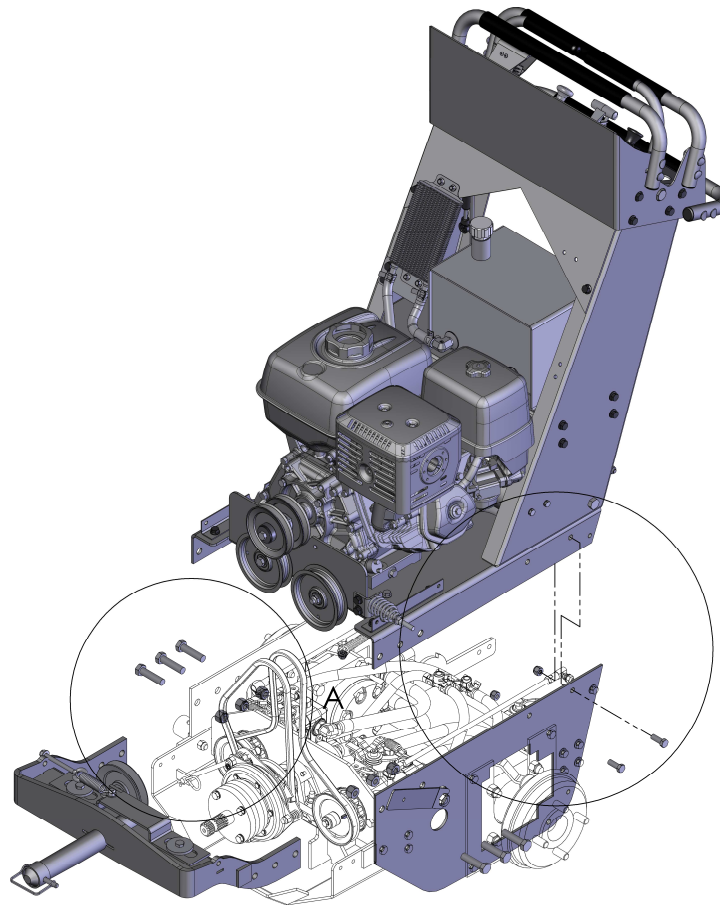

ITEM NO.	PART NUMBER	DESCRIPTION
1	NB604	BOLT - 3/8-16 X 1 GR5
2	NB182	NUT - NYLOC 3/8-16
3	NB281	NUT - NYLOC 1/2-13
4	NB509	BOLT - 1/2-13 X 2 HCC GR5

When Ordering Replacement Parts:

* = USE PAINT CODE: TK=BLACK

KICKSTAND / BRAKE ASSEMBLIES

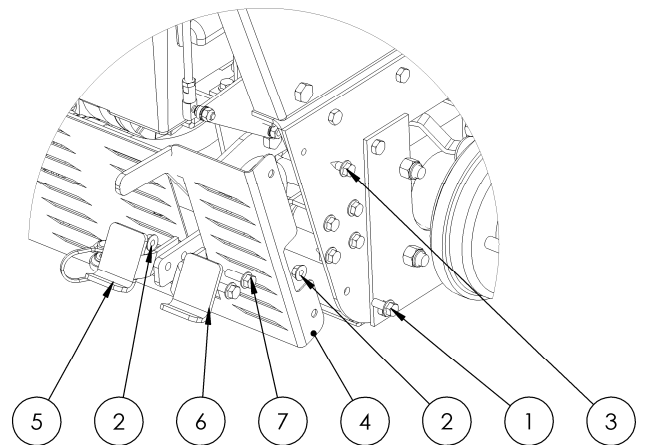
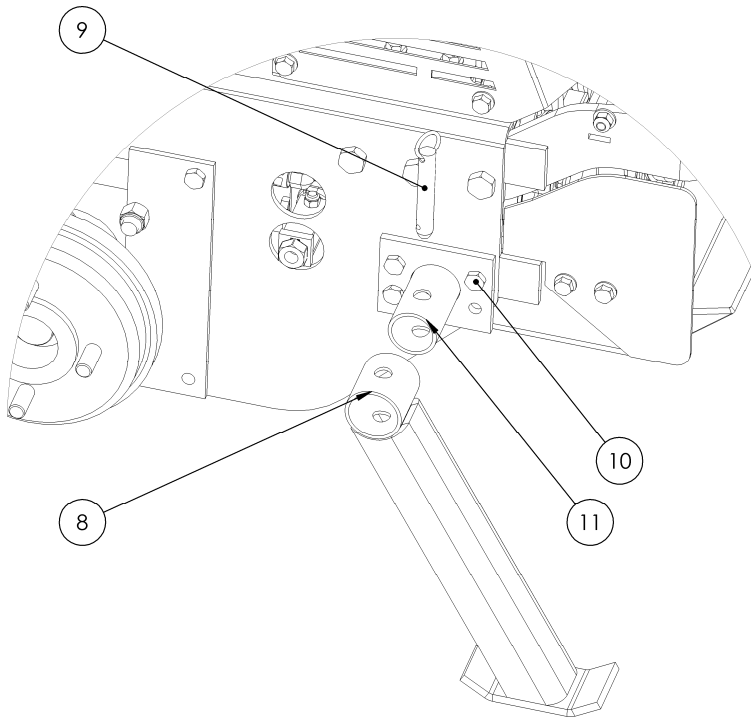
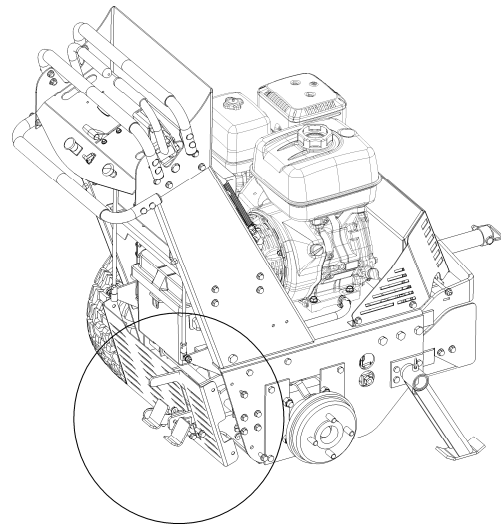
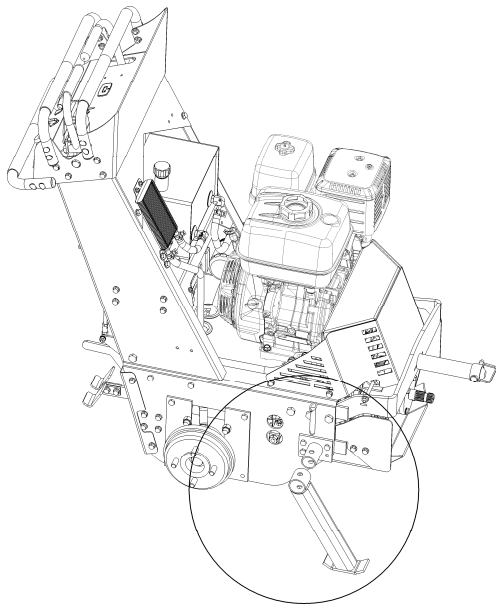

ITEM NO.	PART NUMBER	DESCRIPTION
1	NB596	BOLT - 5/16" X 18 UNC X .75" FLANGE HEAD
2	NB170	NUT - 5/16-18 SERR FLANGE
3	26X249	SCREW - .312-18 X .75 BLACK ZINC
4	21703*	GUARD - WB TRACTOR , REAR
5	21730*	PLATE - BRAKE , PEDAL LEFT
6	21729*	PLATE - BRAKE , PEDAL RIGHT
7	10548	BOLT - SERR FLANGE, 5/16-18 X 1 GR5
8	NB651	PIN - BALL LOCK, 1/2 X 2 1/2
9	21721*	WELDMENT - KICKSTAND, WB
10	NB618	BOLT - 3/8-16 X 1 1/4 GR5
11	21722*	WELDMENT - KICKSTAND, RECEIVER

When Ordering Replacement Parts:

* = USE PAINT CODE: TK=BLACK

COVERS / DRIVE TIRES

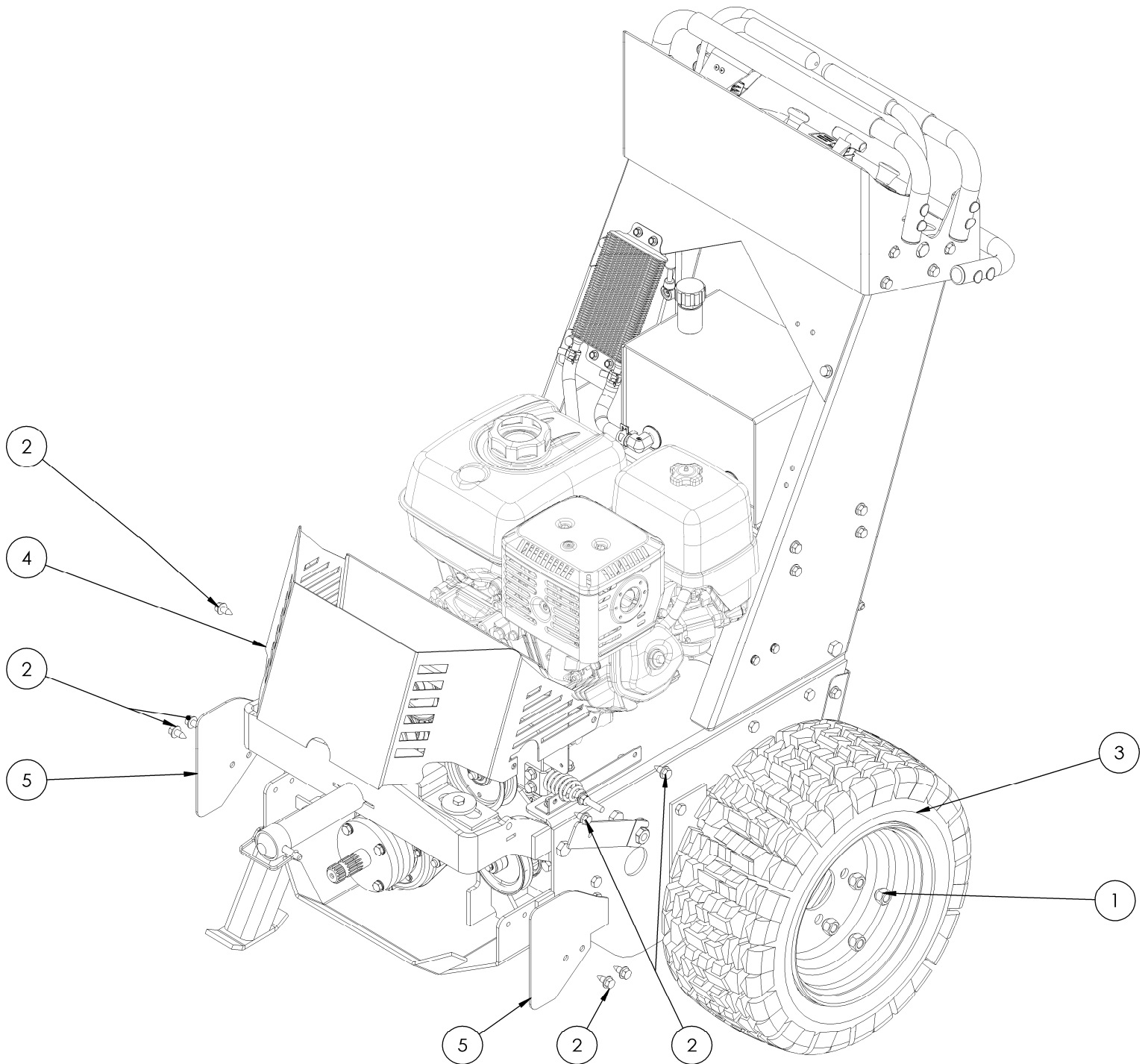

ITEM NO.	PART NUMBER	DESCRIPTION
1	2203LN	NUT - LUG, WHEEL HUB, 1/2-20 GR5
2	26X249	SCREW - .312-18 X .75 BLACK ZINC
3	21514	TIRE - 18X8.50-10
4	21670*	COVER - WB , DRIVE
5	21702*	GUARD - WB , TRACTOR

When Ordering Replacement Parts:

* = USE PAINT CODE: TK=BLACK

WIRING HARNESS 21570

•CONNECTORS SHOWN
FROM WIRE ENTRY END

ELECTRICAL SYSTEM

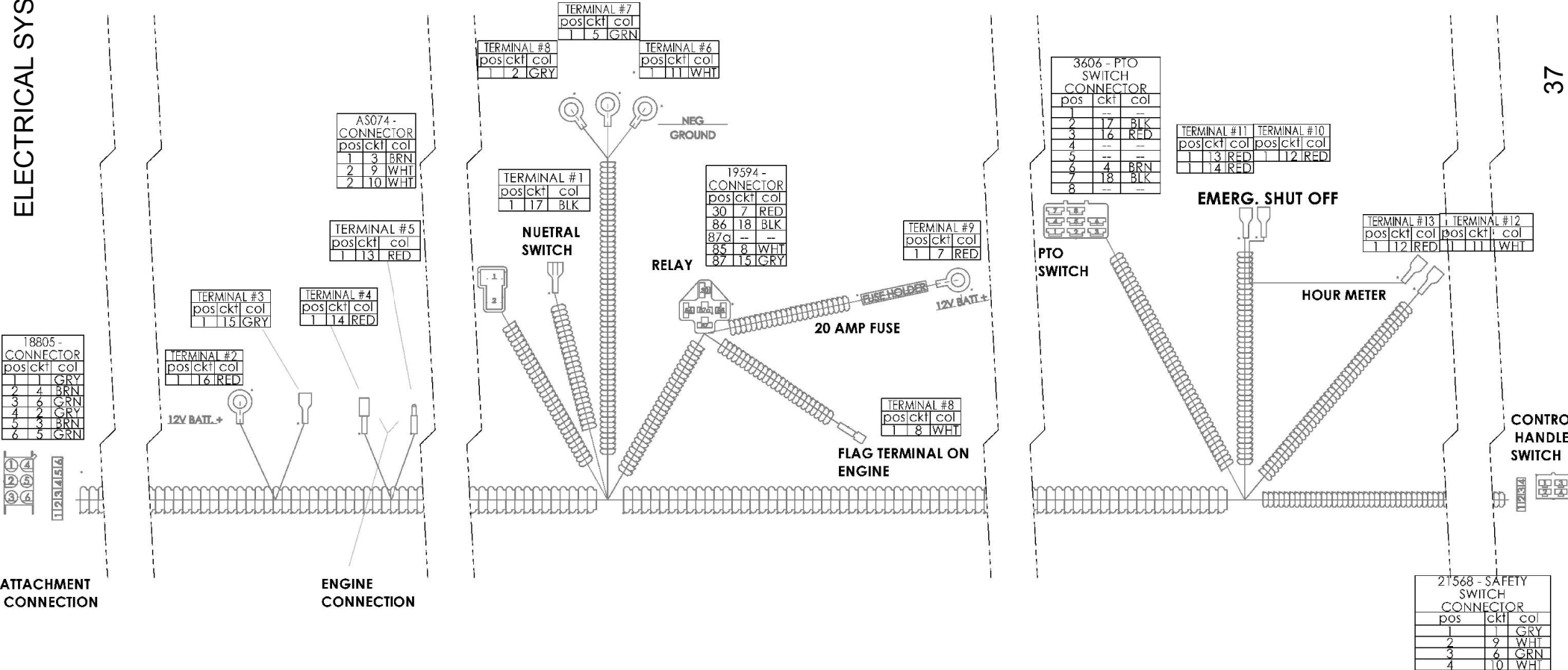

ATTACHMENT CONNECTION

ENGINE CONNECTION

CONTROL HANDLE SWITCH

21568 - SAFETY SWITCH CONNECTOR			
pos	ckt	col	
1	9	GRY	
2	9	WHT	
3	6	GRN	
4	10	WHT	

HYDRAULIC SYSTEM

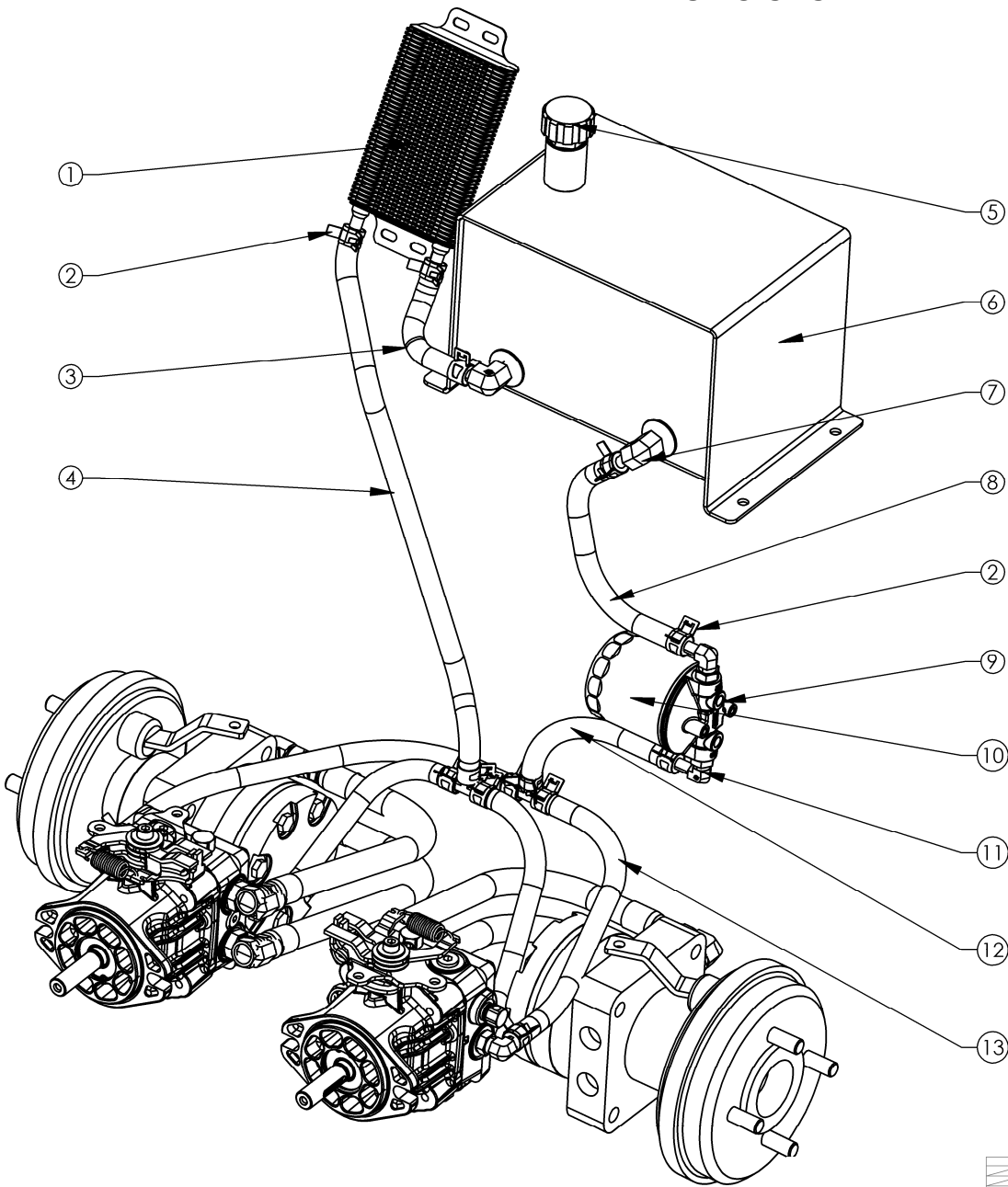

ITEM NO.	PART NUMBER	DESCRIPTION
1	21784	COOLER - OIL, 4 X 6
2	21565	CLAMP - HOSE, 17mm
3	21550	HOSE - 3/8" ID_6.25"
4	21550	HOSE - 3/8" ID_23"
5	12379	3/4" NPT ANTI-SPLASH BREATHER
6	21758*	WELDMENT - RESERVOIR
7	21760	FITTING - 3/8" 90° HOSE BARB
8	NB690	BOLT - SERR FLANGE, 1/4-20 X 3/4 GR5
9	21557	FILTER HEAD - HYDRO-GEAR
10	21556	FILTER - HYDRO-GEAR
11	21548	ADAPTER - HYDRAULIC, 4601-06-06
12	21787*	PLATE - SUPPORT, COOLER
13	21547	HOSE - HYD , 1/2" X 15" , (2) FMLE JIC

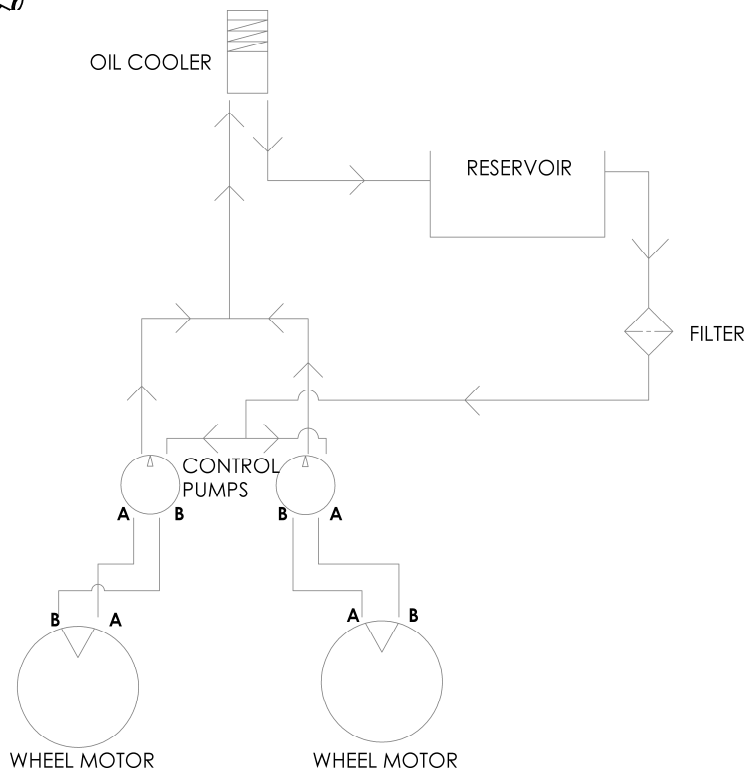

SWISHER HISTORY



Back before electricity came to rural Missouri Max Swisher was producing lawn mowers from his mother's chicken house. Max never liked to mow grass. He installed a gearbox on his family's lawn mower creating a self-propelled unit. By tying one end of a rope to the mower and the other end to a tree in the center of the yard the mower circled the tree, shortening the rope and guiding the mower in concentric circles. Max enjoyed relaxing under a shade tree while his invention did all the work.

Max had designed his first self-propelled rotary lawn mower to do his dirty work for him. Neighbors noticed his new invention and began asking him to make more. Today, over 70 years later, Swisher is still producing innovative lawn and garden and ATV/UTV equipment designed to give us all more "relaxing in the shade" time.

Swisher products have been featured nationally on television programs such as Regis and Kathie Lee and seen in publications like ATV Magazine, Country Journal, Popular Mechanics Magazine and others. In January 2000 Popular Mechanics Magazine named Max's zero turning radius riding mower one of the 20th century's top household inventions.

Swisher offers value and function in its products to meet your grounds maintenance needs.

**CELEBRATING OVER 70 YEARS OF INNOVATION
SINCE 1945**

