

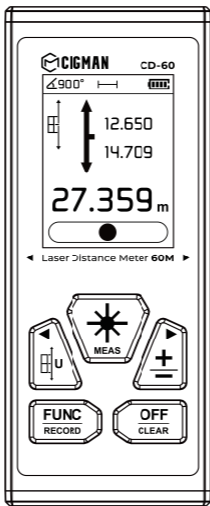

Bilateral Laser Distance Meter

CD-60 User manual





Contact us: support@cigman.com

Languages

User manual - English	1 - 16
Bedienungsanleitung - Deutsch	17 - 32
Manuel d'instructions - Français	33 - 48
Istruzioni per l'uso - Italiano	49 - 64
Manual de instruccin - Español	65 - 80
取扱説明書 - 日本語	81 - 96
Three Years Warranty	97

Safety Regulations

 Before using the instrument for the first time, please read the safety clauses and operating instructions carefully.

 Failure to use the instrument in accordance with the operating methods guided in this manual may cause damage to the instrument, affect measurement accuracy, and cause personal injury to the user or a third party harm.

 Do not open or repair the instrument by yourself in any way, and it is strictly forbidden to illegally modify or change the performance of the laser transmitter of the instrument. Please keep the instrument properly, do not place it in a place where children can touch it, and avoid use by unrelated personnel.

 It is strictly forbidden to irradiate the eyes and other parts of the body of oneself or others with the laser of the instrument, and it is strictly forbidden to irradiate the laser on the surface of highly reflective objects.

 The electromagnetic radiation of the instrument may cause interference with other equipment and devices. Please do not use the instrument near airplanes or medical equipment, and do not use the instrument in flammable and explosive environments.

 Discarded instruments cannot be disposed of together with domestic waste. Please dispose of discarded instruments according to relevant national or local laws and regulations.

Product Features

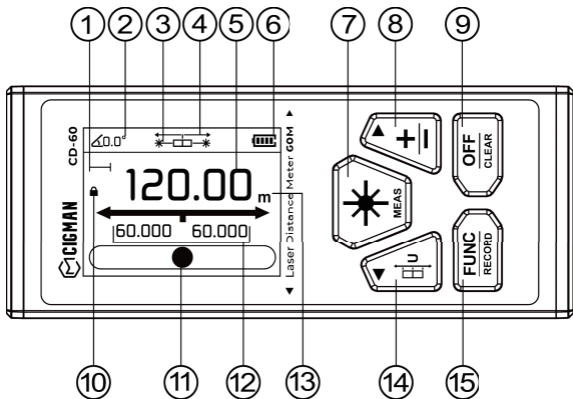

① Measurement mode	② Angle indicator	③ Laser indicator
④ Benchmark indicator	⑤ Main display area	⑥ Power indicator
⑦ Switch on/ Measurement button	⑧ Addition/Subtraction/ Screen lock button	⑨ Switch off/Clear button
⑩ Screen lock indicator	⑪ Level bubble	⑫ Auxiliary display area
⑬ Unit display	⑭ Unit switch/ benchmark measurement	⑮ Function and record button

Basic Function

● Switch on/off the instrument

In the shutdown state, long press the  button. The instrument starts and enters the waiting test mode.

In the running state, long press the  button to turn off the instrument. If there is no operation within 180 seconds, the instrument will be automatically closed.

● Unit setting

Long press the  button to enter the unit switch status, the instrument provides 6 units to choose from.

Unit	Length	Area	Volume
1	0.000 m	0.000 m ²	0.000 m ³
2	0.00 m	0.00 m ²	0.00 m ³
3	0.0 in	0.00 ft ²	0.00 ft ³
4	0 $\frac{1}{16}$ in	0.00 ft ²	0.00 ft ³
5	0'00" $\frac{1}{16}$	0.00 ft ²	0.00 ft ³
6	0.00 ft	0.00 ft ²	0.00 ft ³

● Benchmark measurement setting

Short Press the  button to measure the benchmark, and the default setting is bilateral measurement.

bilateral measurement.

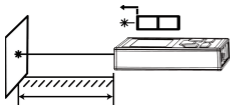

forward-left benchmark

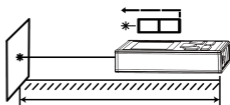

back-left benchmark

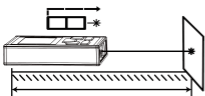

back-right benchmark

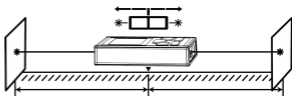

bilateral measurement

● Measurement mode selection

Short press the  button to enter mode selection. Display as follows:











Short press the  or  button to switch mode;



Short press the  button to select mode;

Short press the  button to return.

There are nine measurement modes in the instrument:

	Length measurement		Angle and height measurement
	Area measurement		Indirect height measurement
	Volume measurement		Hypotenuse measurement
	Wall area measurement		Double indirect height measurement
			Auxiliary height measurement

● Rotating the screen and locking

The instrument supports the automatic rotating screen, long press the  button to lock the direction of the screen, the screen displays the  icon. Long press the  button to cancel the screen direction lock.

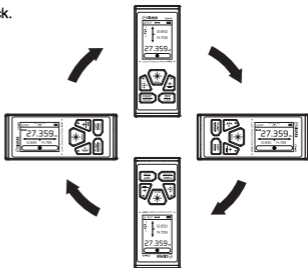

● Electronic level bubble

The instrument is attached to electronic horizontal bubble, which can measure the horizontal level of the plane.

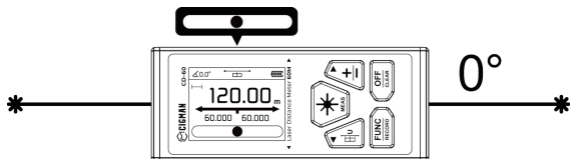

● Strong magnetic adsorption

There is a magnet on the back of the device, which can adsorb the surface of the metal.

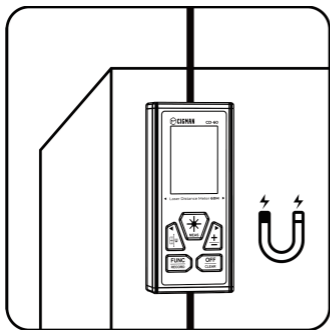

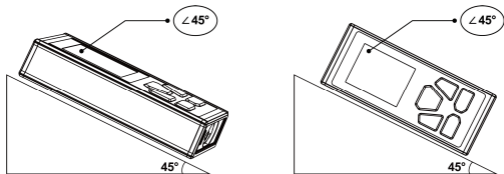

● Angle measurement

The instrument has a built-in dump sensor, which can measure the angle of the bottom side and the side of the side in real-time.







Multiple measurement features

● Length mode-Single measurement :

Press the  button in the length mode, the device sends out a laser point to lock the measurement position. Then press the  button again to do the single distance data measurement. The reading shows in the main display area. On the bilateral measurement, the auxiliary display area displays the distance between the left and right ends.

● Length mode-continuous measurement :

In the length mode, press and hold the  button to enter the continuous measurement state, and the screen displays real-time measurement data, maximum value, and minimum value; short press the  button or  button to once to pause the measurement, press these two buttons again to exit the continuous measurement mode.

Midpoint search: Set the benchmark to a bilateral benchmark, Long press the  button to start the continuous measurement, and find the midpoint according to the following prompts. (When using the bilateral laser to measure, the left and right readings may have a 1mm error.)

Horizontal screen display:

1. The screen displays **【←】**, please move it to the left.
2. The screen displays **【→】**, please move it to the right.

Vertical screen display:

1. The screen displays **【↑】**, please move it up.
2. The screen displays **【↓】**, please move it down.

When the screen displays **→|←**, it means it is currently at the midpoint.

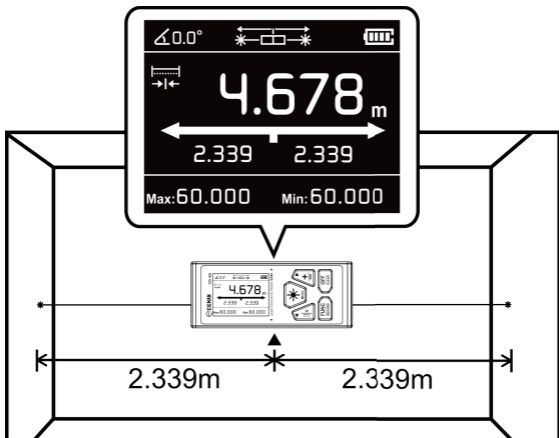

● Area measurement :

Press the  button to measure the first side (length);

Press the  button to measure the second side (width);

The instrument will automatically calculate the area and display it in the main display area. The auxiliary display area shows the length and width measurements. During the measurement, you can also press the  button to clear the current reading and re-measure.

● Volume measurement :

1. Press the  button to measure the first side (length);

2. Press the  button to measure the second side (width);

3. Press the  button to measure the third side (height);

4. The instrument will automatically calculate the volume and display it in the main display area. The auxiliary display area displays the measured values of the cube's length, width, and height.

During the measurement, you can also press the  button to clear the current reading and re-measure.

● Wall Area Measurement :

1. Press the  button to measure the height of the wall;

2. Press the  button to measure the width 1 of wall 1;

The instrument will automatically calculate the area of the wall =height x width 1;

3. Press the  button to measure the width 2 of wall 2;

The instrument will automatically calculate the sum of the area of the wall.

Sum of area = height x (width 1+width 2);

4. By analogy, press the  button to measure the width n of the wall n;

Sum of area = height x (width 1+width 2+...+width n);

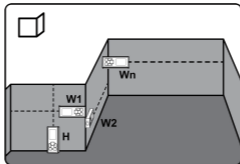

During the measurement, you can also press the **OFF CLEAR** button to clear the current reading and re-measure.

● Indirect Measurement:

① Measure the angle and height of a right triangle  (as shown in figure 1)

Press the  Button, and follow the prompts on the screen to measure the length of the hypotenuse (**a**);

The instrument can simultaneously measure the angle between the hypotenuse and the base-side (**θ**);

The instrument can automatically calculate the horizontal distance (**b**) and the vertical height (**h**).

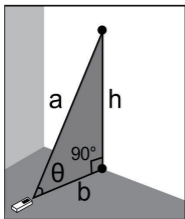

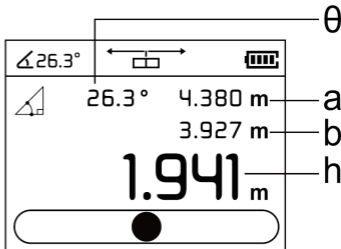

(figure 1)



(screen display)

② Measure the height of a right triangle  (as shown in figure 2).

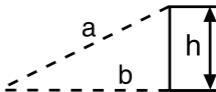

(as shown in figure 2).

1. Press the  button, and follow the prompts on the screen to measure the length of the hypotenuse (**a**);
2. Press the  button, then measure the length of the right-angled side (**b**);
3. The instrument will automatically calculate the height (**h**) of the triangle after the second measurement.



(figure 2)



③ Measure the hypotenuse of a right triangle  (as shown in figure 3).

1. Press the  button to measure the length of a side according to the prompt on the screen (**a**);
2. Press the  button to measure the length of a right-angled edge (**b**);
3. The instrument will automatically calculate the hypotenuse (**x**) of the triangle after the second measurement.



(figure 3)

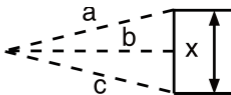

④ Measure the double indirect height of an isosceles triangle  (as shown in figure 4)

1. Press the  button, and follow the screen prompts to measure the length of one hypotenuse (**a**);
2. Press the  button, then measure the length of the right-angled edge (**b**);
3. Press the  button to measure the length of the other hypotenuse (**c**);
4. After the measurement, the instrument automatically calculates the height of the triangle (**x**).



(figure 4)

⑤ Measure the auxiliary height of the triangle  (as shown in figure 5)

1. Press the  button, and follow the prompts on the screen to measure the length of a hypotenuse (**a**);
2. Press the  button to measure the length of the other side (**b**);
3. Press the  button to measure the length of another hypotenuse (**c**);
4. After the measurement, the instrument will automatically calculate the auxiliary height (**x**) of the triangle.

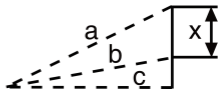

(figure 5)

Notice:

In the Pythagorean measurement mode, the instrument can only calculate the length of the right-angled side which must be less than the hypotenuse. Otherwise, the instrument will display an error signal.

In the Pythagorean measurement mode, in order to ensure accuracy, it must be measured from the same starting point and measured in the order of hypotenuse and right angle.

● Addition and Subtraction measurement:

1. Length cumulative addition and subtraction



In length mode, measure a set of data.

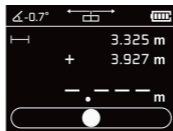

Short press the  button to enter the cumulative mode.



Then measure the data, the instrument will automatically accumulate and sum.

Short press the  button, "+" will appear in the main display area to enter the

cumulative addition measurement mode. Then continue the measurement, and the instrument will automatically cumulative addition.

In the accumulative mode, short-press the  button again. The "-" icon will appear in the main display area to enter the cumulative subtraction measurement mode. Then continue the measurement, and the instrument will automatically cumulative subtraction.

2. Area, Volume in cumulative addition and subtraction

The Volume accumulated addition and subtraction operations are the same as Area accumulated addition and subtraction. Here is the sample for Area accumulated addition and subtraction:



figure ①

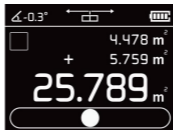



figure ②





figure ③

Step 1, measure the area once (as shown in figure ①).

Step 2, short press the  button, "+" will appear in the main display area, enter the cumulative addition measurement mode, and then measure the second area (as shown in figure ②).





Step 3, short press the  button, and the device will automatically calculate the sum of the two areas (as shown in figure ③).

Volume cumulative addition and subtraction: In step 1, short press the  button to enter the accumulation, then short press the  button switch to cumulative subtraction mode. the subsequent operations are similar to cumulative addition and will not be described again.



Multiple cumulative addition/subtraction operations:

In step 2, after obtaining the area for the second time, short press the  button again. You can continue to cumulative addition/subtraction for the next area. Finally, follow step 3 to obtain a result.

Recording

- After the instrument measurement is completed, the result will be automatically stored.
- Long press the  button to view the records; short press the  or  button to look back at the records; Long press the  button to clear all records.

Charging

- The device displays , indicating that the battery is insufficient. Reminds the user should charge it immediately to avoid affecting the accuracy of measurement.
- Please use a compliant charger with DC5V \geq 1A output for charging, and it is recommended to use a mobile phone charger.
- Charging indication: The instrument scrolls to display , indicating that it is not fully charged. When it displays , and no longer scrolling, it means full.
- Battery maintenance: If you don't use it for a such long time, it is recommended to fully charge the device first, and recharge it every six months to avoid discharge damage in the battery.

Prompt information

During use, the following prompt information may appear in the main display area:

Signal	Reason	Solution
Err	Out of measure range	Let the instrument work in an effective measurement range
Err1	Signal is too weak (black wall, over working distance)	To measure highly reflective target points (a light color wall or target)
Err2	Signal is too strong (Indoor smooth surfaces (tiles, smooth painted surfaces, etc))	To measure weakly reflective target points (a light color wall or target)
Err3	Battery voltage is too low	charge the battery
Err4	Out of operating temperature range	Let the instrument be used in the specified environment
Err5	Pythagorean Measurement Violations	Re-measure to make sure the hypotenuse is larger than the right-angle side
Err6	Angle sensor error	Return to factory for repair

Device Routine Maintenance

- It is forbidden to store the instrument in a high-temperature and high-humidity environment for a long time. When the instrument is not used for a long time, please place the instrument in the random instrument case and store it in a cool and dry place.
- Please keep the surface of the instrument clean, wipe the surface dust with a damp soft cloth, and do not clean the instrument with corrosive lotions. The laser window and focusing mirror can be cleaned in the same way as the optics table.
- In harsh environments such as: 1. the sunlight is too strong, 2. the ambient temperature fluctuates too much, 3. the effect of the reflective surface is weak, 4. the battery is insufficient. The accuracy will be affected by these environments. It is better to use the target reflector in this case.

Technical Parameters

Function	Description
Maximum measure distance	60m (one-way) /120m (bilateral)
Minimum measure distance	0.05m
Measurement accuracy	$\pm(2\text{mm}+d*1/10000)$ * (one-way)
Inclination measure range	$\pm 90^\circ$
Continuous measurement	✓
Area and volume measurement	✓
Wall area measurement	✓
Pythagorean measurement	✓
Angle and altimetry measurement	✓
Length addition and subtraction	✓
Max / Min display	✓
Electronic level bubble	✓
Auto switch screen	✓
Magnetic attraction	✓
Laser class	II
Laser type	630-670nm. <1mW
Automatic cut-off laser	20 seconds
Automatic shut-down	180 seconds
Backlight time	60 seconds
Power supply	3.7V 850mAh lithium battery
Charging port	DC5V 0.75A Type-C
Working time	One-way: 12000 times; two-way: 8000 times
Storage temperature	-20°C~60°C
Working temperature	0°C~40°C
Storage humidity	20%~80%RH
Dimensions	115*50*24.5mm

* "d" indicates the actual distance