

MODEL: PP20WPK
Product No: A020010005
2" WATER PUMP

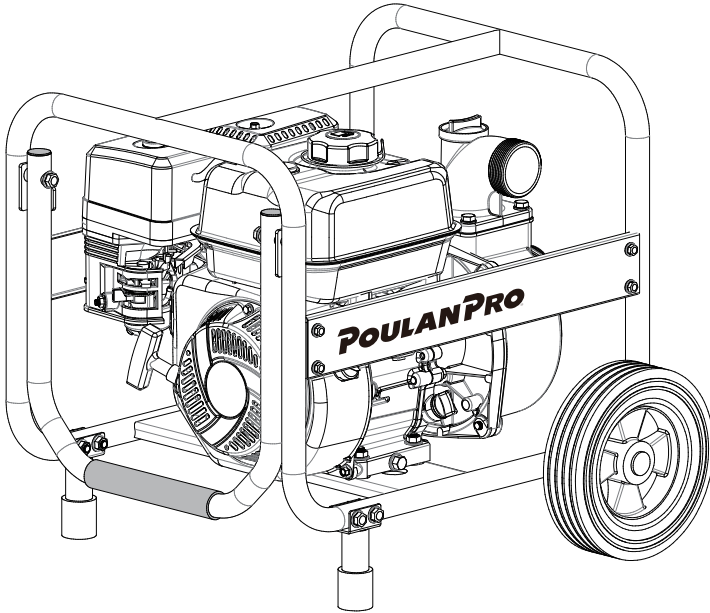

Have product questions or need technical support?

Contact Us:



Website: www.poulanpro.com



Toll free: 1-888-676-7909 Mon-Fri 8-4 CST



Email: support@poulanpro-power.us



READ AND UNDERSTAND THE OPERATOR'S MANUAL AND ALL SAFETY WARNINGS BEFORE USE

Failure to operate the product correctly can result in damage to the product, personal property and cause serious injury or death.

Manufactured under license from Husqvarna AB
Poulan Pro[®] is a registered Trademark of Husqvarna AB
Imported by Novus Performance Products
W225N16708 Cedar Park Ct. Jackson, WI



Vol. 2025-01

Quick Start Guide Contents

- Unpacking
- Package Contents
- Set-up and Starting Procedures

UNPACKING

- ▶ Carefully remove the water pump and all loose components from the carton.
- ▶ Verify all parts listed below are included.
- ▶ If any parts are missing, please contact our customer support team at 1-888-676-7909 for assistance.



CAUTION should be taken when lifting unit, as the weight of unit may exceeds 50 lbs. Recommend a two person lift when removing unit from carton. Place unit on the ground or other solid surface.

PARTS INCLUDED

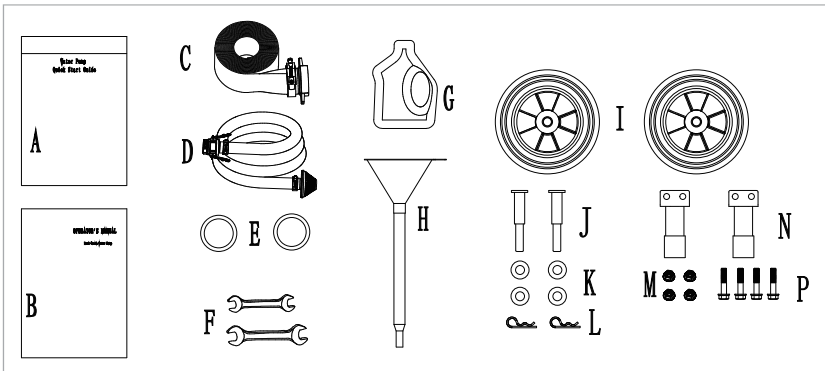

A	Quick Start Guide
B	Operator's Manual
C	Discharge Hose Assy
D	Suction Hose Assy
E	2 X Sealing Washer (Hose coupler)
F	Tool Kit (contains 13/16mm & 10/12mm Wrench)
G	Oil Bottle (20oz - 0.6L) 10W-30
H	Oil Funnel with Tube
I	2 x Wheel
J	2 X Axle Pin
K	4 X Washer
L	2 X Cotter Pin
M	4 X Nut
N	2 X Support Leg
P	4 X Bolt

ASSEMBLY

Install Wheels & Support Legs

1. Insert axle pin (A) into wheel assembly (B), place washer (C) onto axle pin, slide through the wheel mount bracket and install washer (D), then secure with cotter pin (E). Repeat for second wheel.

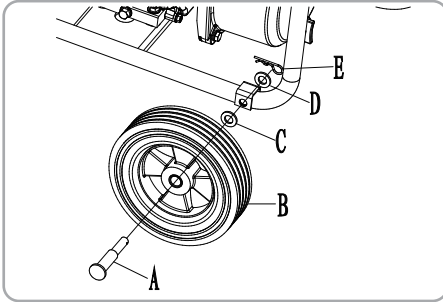

2. Install the support legs (B) using 4 x M8 x 40mm bolts (A) and 4 x M8 lock nuts (C) as shown.

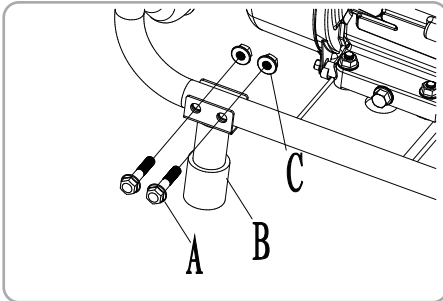

Add Engine Oil



Important Note: Engine crankcase is shipped without oil.

1. Place the unit on a flat, level surface.
2. Remove dipstick / oil fill cap to add engine oil.
3. Using a funnel, add up to 20.3 fl. oz. (0.6 L) of oil to the engine. The oil should be near the top of the fill neck.
4. Check the oil level using the dipstick. DO NOT screw in when checking.
5. When finished screw in the dipstick / oil fill cap securely.

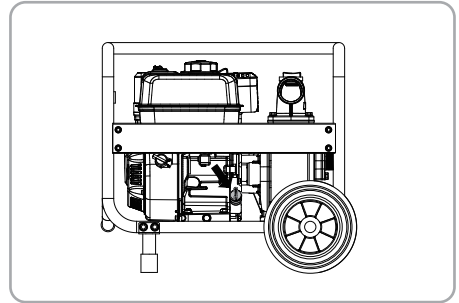

Add Fuel

1. Remove the fuel tank cap.
2. Slowly add gasoline to the tank until it reaches the Red fuel level indicator of the fuel screen. DO NOT overfill. A minimum of ¼ in. (6.4 mm) of space left in the tank is required for gasoline expansion.
3. Replace and tighten the fuel tank cap.
4. Immediately wipe up any spills.

STARTING AND OPERATING PROCEDURES

This section of the quick start guide provides basic instructions on how to start and operate your new water pump. This quick start guide is not a comprehensive guide, we recommend the operator's manual is read and understood before using your new equipment.

UNIT PREPARATION

Prior to starting the engine, the water pump must be prepared for use.

NOTE: Reference Operators Manual for detailed set-up and safety instructions.

1. A hose coupler must be securely fitted to both the inlet and discharge ports of the water pump.
2. A reinforced non collapsible wall inlet (suction) hose and standard discharge hose must be securely installed onto the unit.
3. The strainer must be installed to one end of the Inlet (suction) hose, this end is to be submerged in the pool of water.
4. The pump must be primed with water prior to operation.

NOTE: Damage caused by a dry pump startup is a non-warrantable condition.

5. Remove the priming cap located at the top of the water pump by turning counterclockwise.
6. Prime the pump by adding water through the priming port until the water flows out of the pump discharge outlet.
7. Re-install and tighten the priming cap.

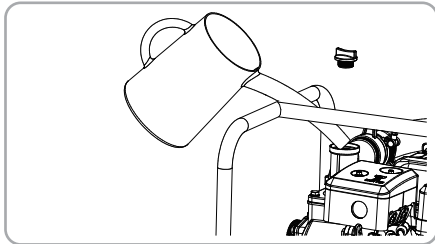
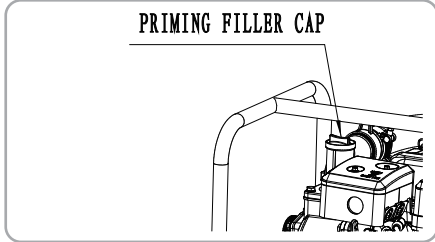

Starting the Engine

1. Check oil level and add oil if necessary.
2. Make certain the unit is on a flat, level surface.
3. Slide the Choke Lever (A) to the full CHOKE position (Fully Left).
4. Move the Fuel Valve lever (B) to the ON position (Fully Right).
5. Turn the Engine ignition switch (C) to the ON position.

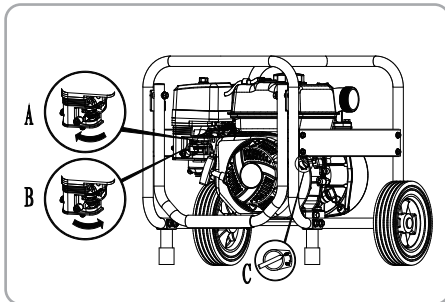

6. Pull the starter handle slowly until resistance is felt, then pull rapidly.

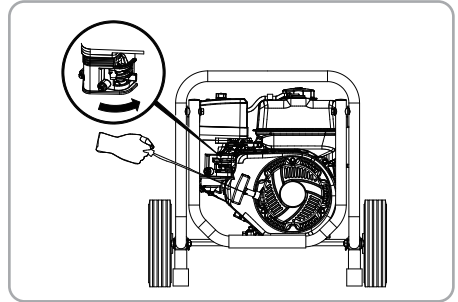

NOTE: Return the starter handle slowly back to the engine to prevent damage to the starter.

7. Once engine starts, slowly move the choke lever to the open position.

Stopping the Engine

1. Slide the Fuel shut-off lever fully to the Left (Off position).

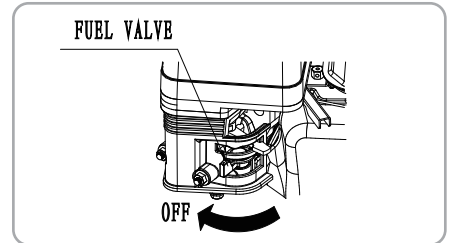

2. Turn the engine ignition switch to the OFF position.

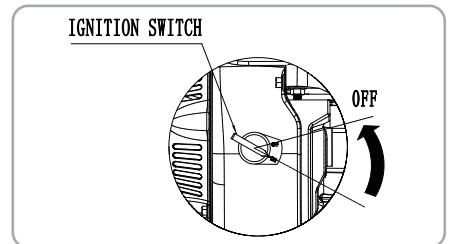

KEY COMPONENTS

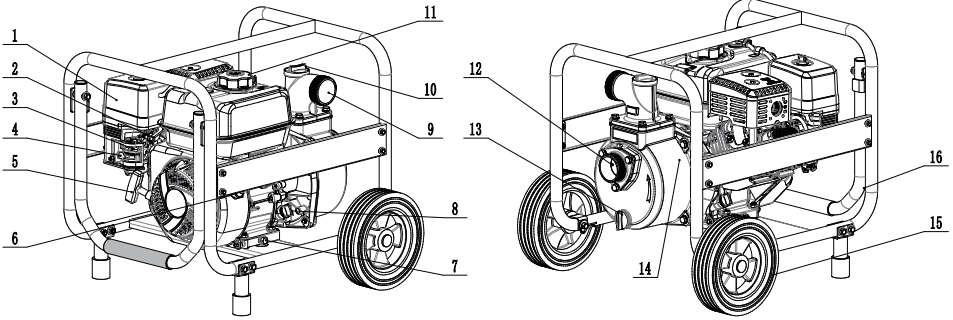

1	Air Filter
2	Throttle Lever
3	Choke Lever
4	Fuel Valve Lever
5	Recoil Starter Grip
6	ON / OFF Switch
7	Oil Drain Plug
8	Dipstick / Oil Fill Cap

9	Outlet / Discharge Port
10	Priming Filler Cap
11	Fuel Cap
12	Inlet / Suction Port
13	Pump Drain Cap
14	Product ID Lables
15	Wheel
16	Handle