









# Assembly Instructions

**Caution : You must read this before you proceed**

## Care & Maintenance

- ⊘  • Not for commercial use. For residential use only.
- ⊘  • Do not put hot items directly on furniture surface.
- ⊘  • Do not clean furniture with harsh cleansers or polish.
- ✓  • To obtain the longest lifespan of your outdoor products, minimizing exposure to direct sunlight is recommended.
- ⊘  • Children should not climb or jump on the furniture.
- ⊘  • Do not write on furniture without a padded barrier to protect the surface.
- ✓  • To obtain the longest lifespan of your outdoor products, avoid extended and lengthy exposure to rain, snow, and direct sunshine. Whenever possible cover the product and /or place under patio or awnings.
- ⊘  • Stains may be removed with mild soap solution and damp cloth.





- ✓  • Dust and pick-up spills using a clean, non-colored, lint-free cloth.

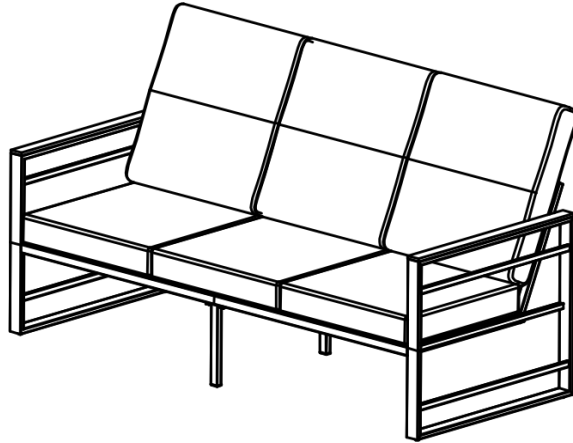



Please look in boxes for hardware packs and legs.  
Sets often ship in multiple boxes and may arrive a day or two apart.

# Three-seater Sofa









## Parts List

Label	Picture	Description	QTY
A		Three-seater Sofa Left Seat Frame	1
B		Three-seater Sofa Right Seat Frame	1
C		Three-seater Sofa Left Back Frame	1
D		Three-seater Sofa Right Back Frame	1
E		Left Armrest	1

F		Right Armrest	1
G		Three-seater Sofa Legs	1
H		Seat Cushion	3
I		Back Cushion	3
N		Three-seater Sofa Legs	1

## Hardware

Label	Picture	Description	QTY
①		Allen Wrench	1
②		Bolt+Washer (M6*35MM)	9
③		Bolt+Washer (M6*45MM)	5
④		Bolt+Washer (M6*20MM)	5
⑤		Bolt+Washer (M6*70MM)	3
⑥		NUT (M6)	4
⑦		Nut Wrench	1

# Assembly Preparation

Before Beginning Assembly:

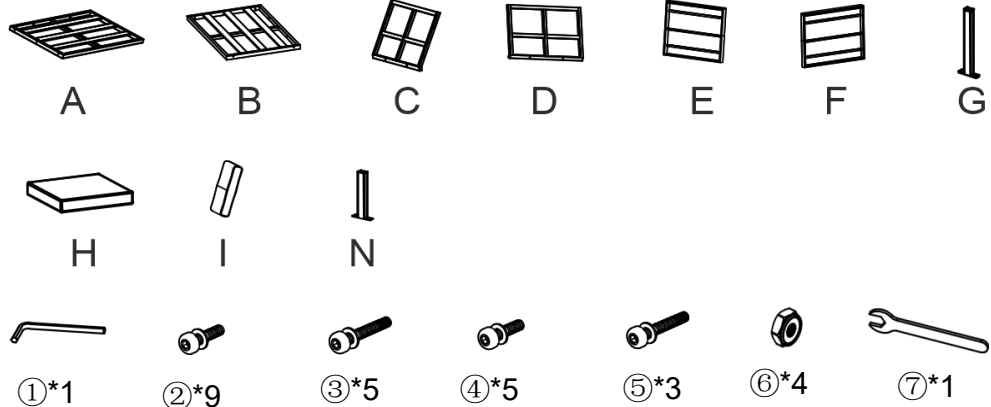

- Read instructions, cover to cover-



- Have 2 adults on hand for assembly-



- Do not assemble on flooring or carpet-



- Assemble on a clean non-marring surface (packing foam)-



- Save all packaging until finished-

# Assembly Steps

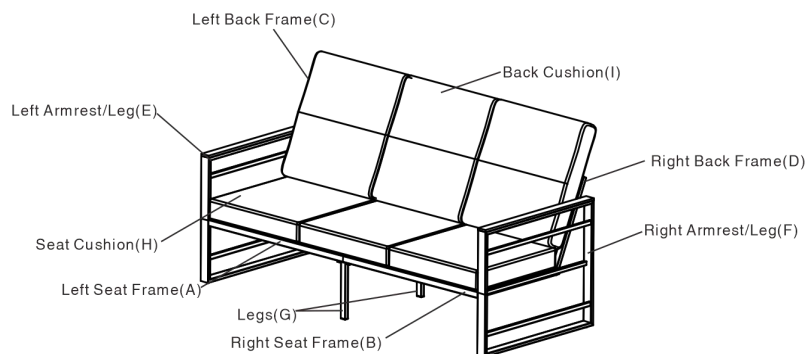

**FRONT FACING**

This Sofa has multiple parts and may require up to 30 minutes to assemble. To give you an overview of the Sofa parts, the above picture is to help you put the various parts into perspective. Please read through the instructions below to familiarise yourself with the parts and steps before assembly.

## Step 1

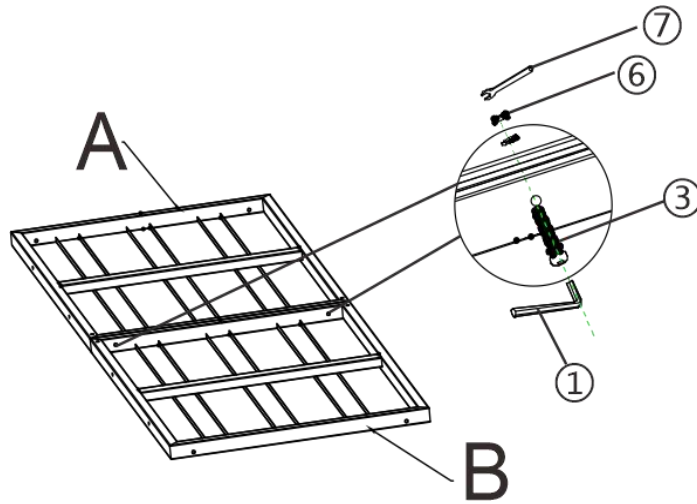

Open the carton and place all the parts onto a clean, non-marring surface.

1.1) Use Bolt+Washer (M6\*45MM)(③)、Nut(M6)(⑥)、Nut Wrench(⑦) and Allen wrench(①) Connect the Three-seater Sofa Left Seat Frame(A) to the Three-seater Sofa Right Seat Frame(B) as shown in the above picture.

**Do not fully tighten the Bolts.**

## Step 2

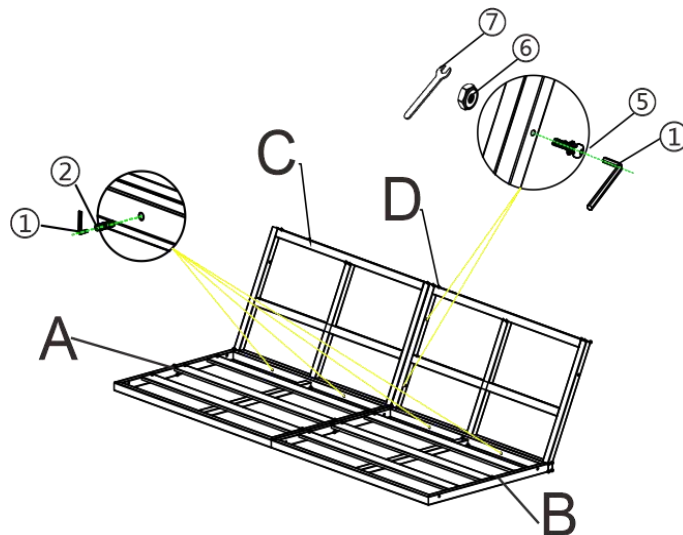

2.1) Use Bolt+Washer (M6\*35MM)(②)、Bolt+Washer (M6\*70MM)(⑤) and Allen wrench(①) connect the Three-seater Sofa Left Seat Frame(A) and Three-seater Sofa Right Seat Frame(B) to the Three-seater Sofa Left Back Frame(C) and Three-seater Sofa Right Back Frame(D) as shown in the above picture.

**Do not fully tighten the Bolts.**

### Step 3

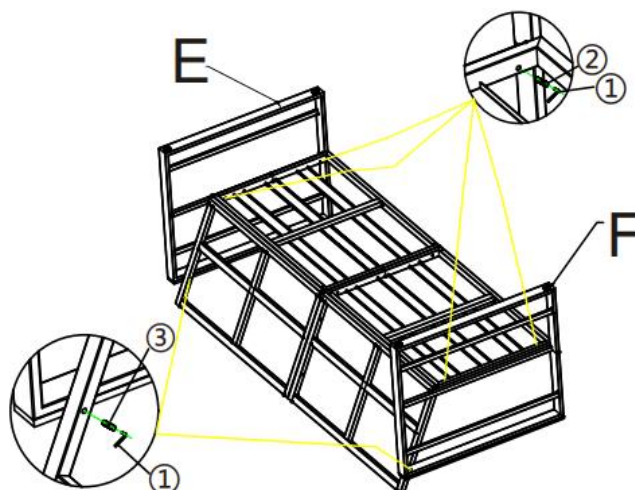

3.1) Place the Three-seater Sofa upside down on the ground.

3.2) Use Bolt+Washer (M6\*35MM)(②)、 Bolt+Washer (M6\*45MM)(③) and Allen wrench to connect the Left Armrest (E) and Right Armrest (F) to the frame as shown in the above picture.

**Do not fully tighten the Bolts.**

### Step 4

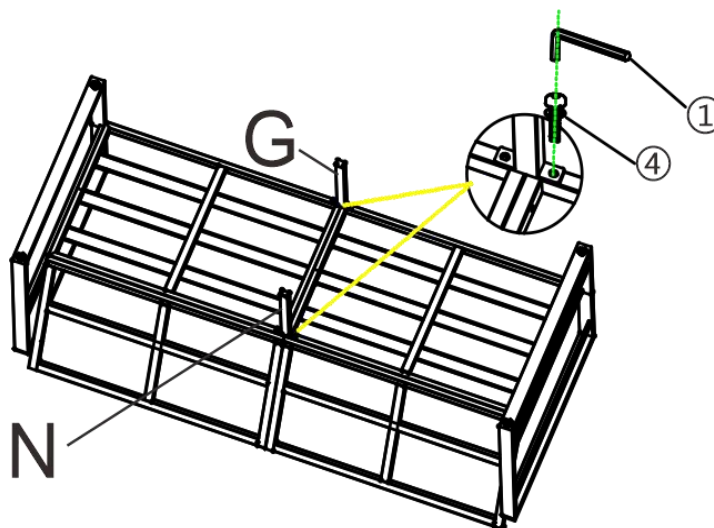

4.1) Use Bolt+Washer (M6\*20MM)(④) and Allen wrench(①) connect the Three-seater Sofa Legs(G) to the Three-seater Sofa Seat Frame as shown in the above picture.

**Do not fully tighten the Bolts.**

## Step 5

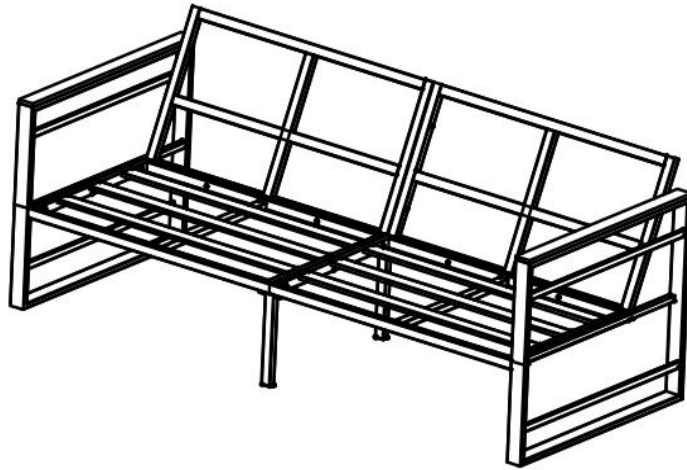

Place the Three-seater Sofa on a **LEVEL SURFACE**.

Inspect it and make sure all parts are adequately connected.

Gently and carefully sit onto the Three-seater Sofa.

This will help to align all parts at all joints.

Then get off the Three-seater Sofa, and in a sequential manner, proceed to tighten all Bolts.

When tightening the Bolts, tighten sequentially.

**DO NOT** tighten any Bolt fully and then move on to the next one.

This may cause the frame to warp.

If there are any wobbles after tightening, loosen the Bolts and execute this same process.

**Note: This step is done best with the assistance of a second adult.**

## Step 6

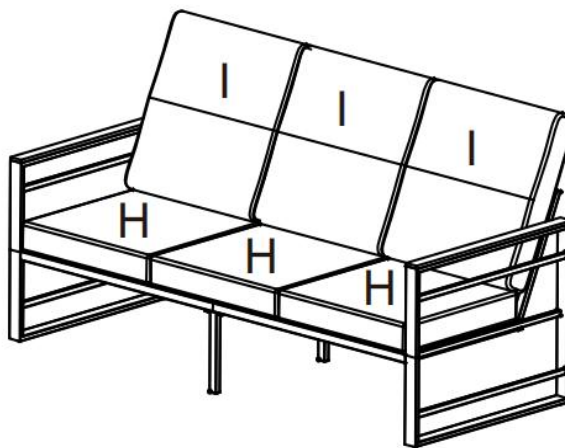

Place the three Back Cushions(I) in front of the Back Frame.

Place the three Seat Cushions(H) on the Seat Frame.

Your Three-seater Sofa is ready for use.

This Three-seater Sofa can only be used on a flat and level surface.