

# WASHER DRYER COUNTERTOP

Always read the assembly instructions carefully before beginning assembly.

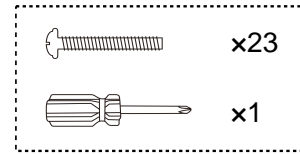
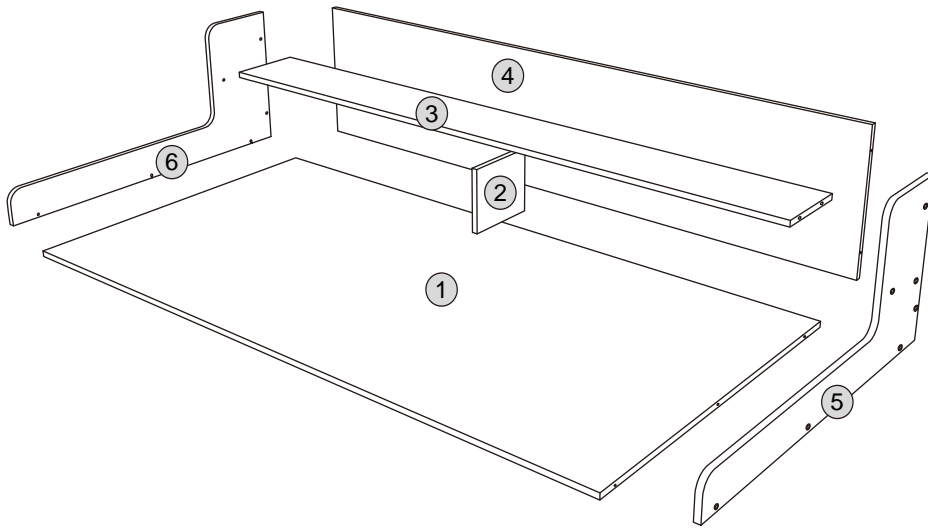

## CRITICAL REMINDER:

Our design includes pre-allocated mounting positions for nuts (as shown in the picture).



Verify orientation before assembly.

### Step 1

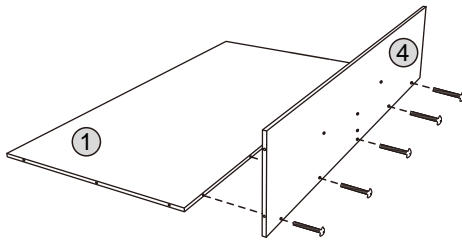

### Step 2

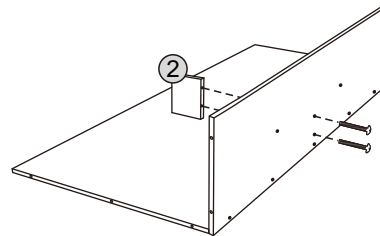

### Step 3

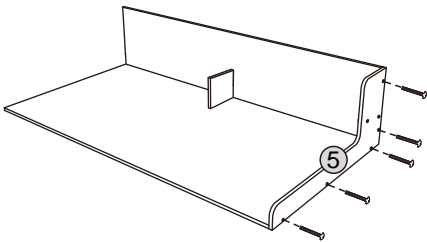

### Step 4

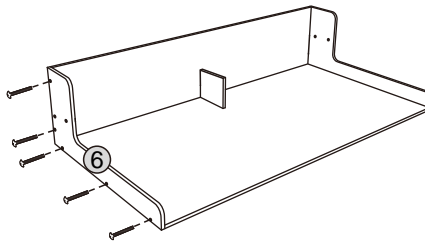

### Step 5

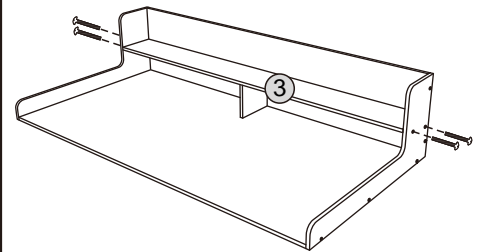

### PRE-ASSEMBLY PREPARATION:

1. Ensure that you have all required contents for complete assembly
2. Choose a clean, level, spacious assembly area. Avoid hard surfaces that may damage the product.
3. Keep all hardware parts and packaging out of reach of small children.
4. Take care when lifting. Product should be assembled as near as possible to the point of use.
5. Do not over tighten the screws and bolts as this may damage the threads.