

INSTALLATION INSTRUCTION FOR ST-EDTBAR(F) #1100 SERIES FIRE EXIT DEVICE

BEFORE INSTALLING DEVICE, PLEASE CHECK :

- 1 IF DOOR FITTED AND HUNG
- 2 SIZE OF EXIT DEVICE, FUNCTION AND DESIGN.
 - 2.1 36" DOORS, CAN BE CUT TO FIT DOORS DOWN TO 30" WIDE
 - 2.2 48" DOORS, CAN BE CUT TO FIT DOORS DOWN TO 36" WIDE
 - 2.3 HAND OF DEVICE AGAINST APPLICATION

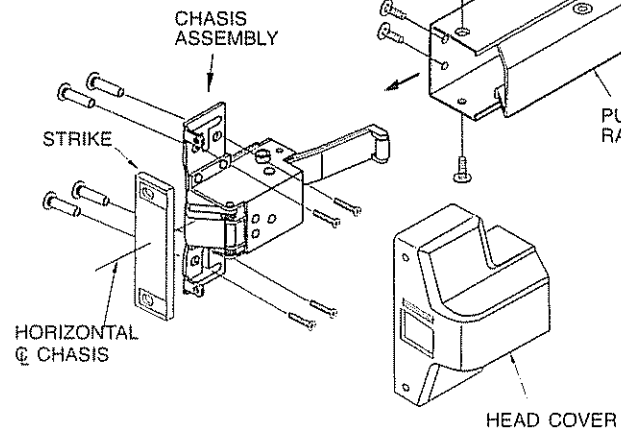
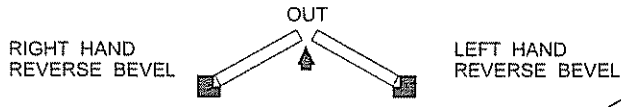

1. TYPE OF INSTALLATION

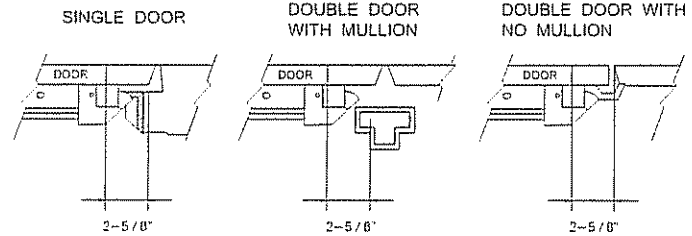

2. APPLY HARDWARE

- 2.1 DRILL HOLES
MARK DOOR FACE AND DRILL HOLES IN ACCORDANCE WITH THE DIAMETERS SUGGESTED SEE ATTACHED TEMPLATE

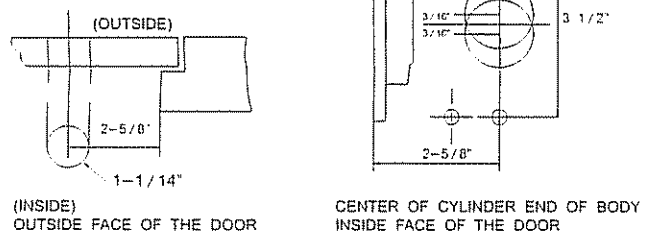

2.2 INSTALL CYLINDER

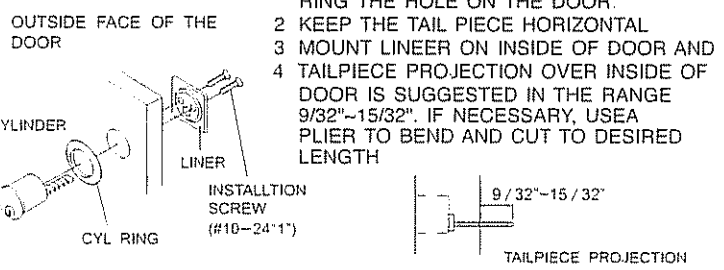

2.3 INSTALL LEVER, OR KNOB, OR PULL TRIM

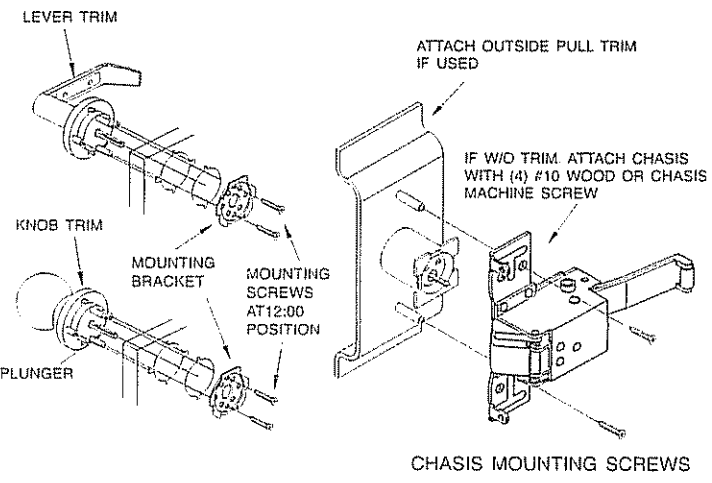

3. APPLY RAIL ASSEMBLY

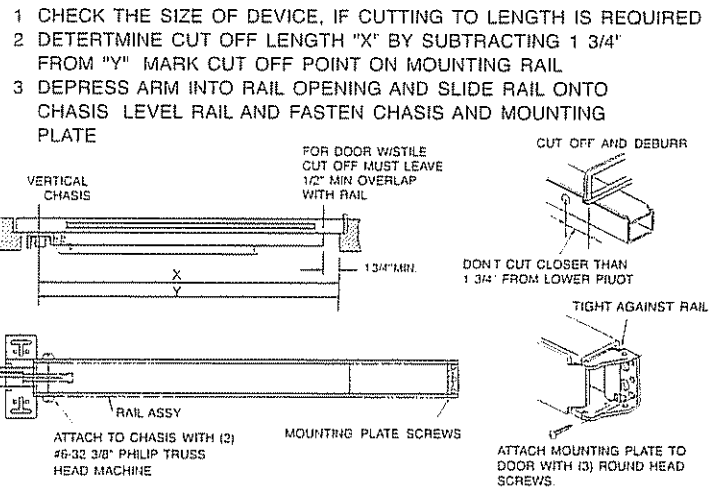

4. APPLY COVER AND STRIKES

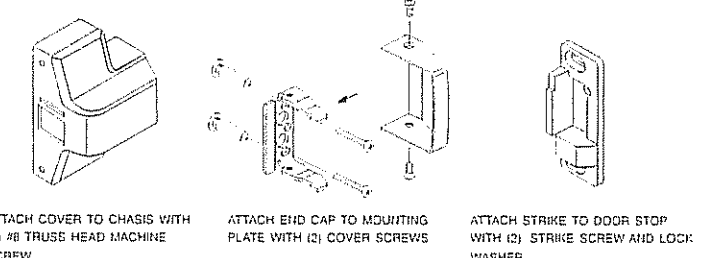

TEMPLATE

FOR EDTBAR AND SVRTBAR SERIES EXIT DEVICE
USING LEVER HANDLE TRIM

FOR WOOD DOORS :
DRILL(4) 3/32" DIA.X 1-1/4"
DEEP PILOT HOLES
FOR METAL DOORS :
TAPPED(4)#3/16" HOLES.

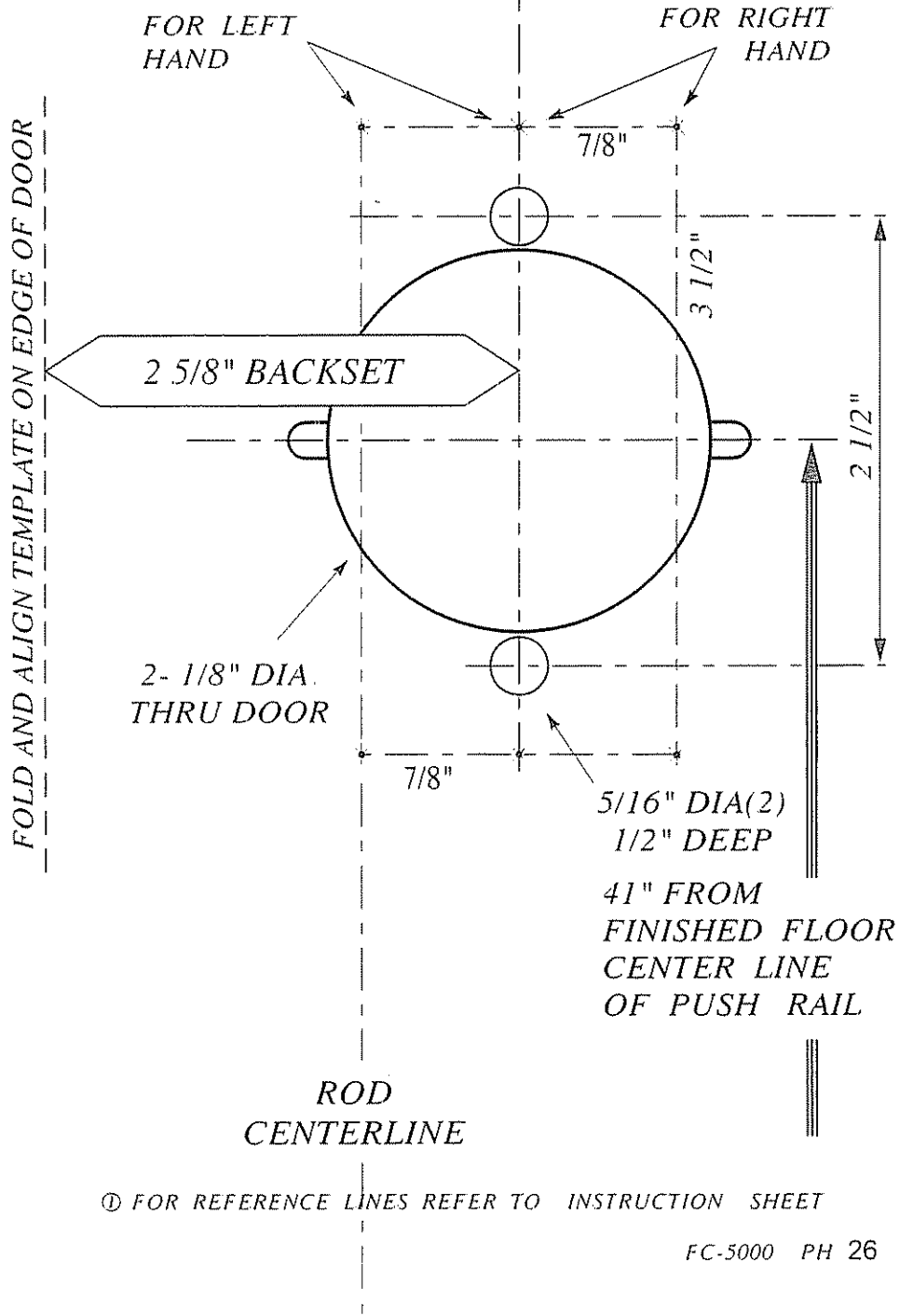

TEMPLATE

FOR EDTBAR AND SVRTBAR SERIES EXIT DEVICE
USING LEVER HANDLE TRIM
OR ON TRIMS

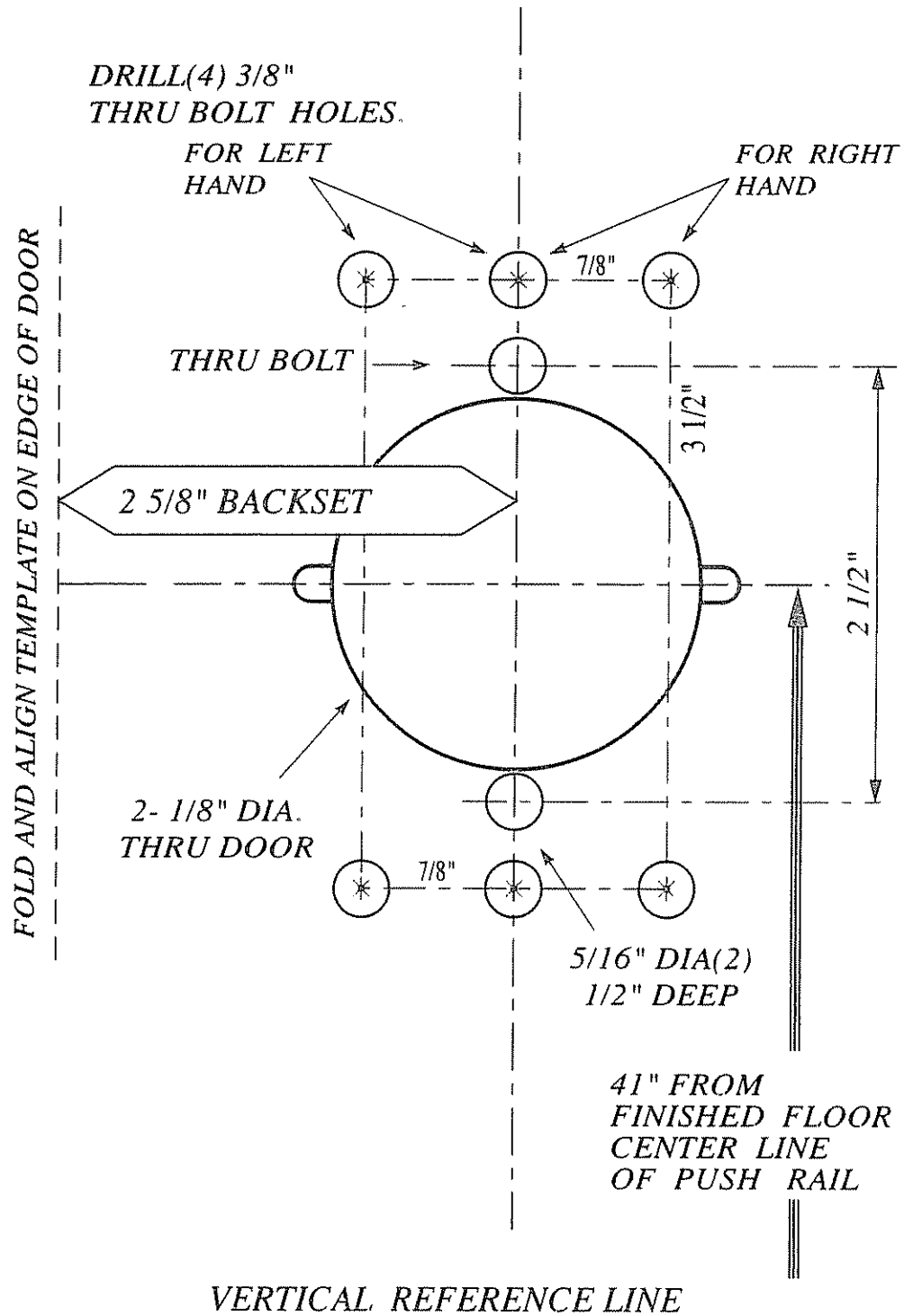

① FOR REFERENCE LINES REFER TO INSTRUCTION SHEET

FC-8000# PH 26A

TEMPLATE

FOR EDTBAR AND SVRTBAR SERIES EXIT DEVICE USING LEVER HANDLE TRIM

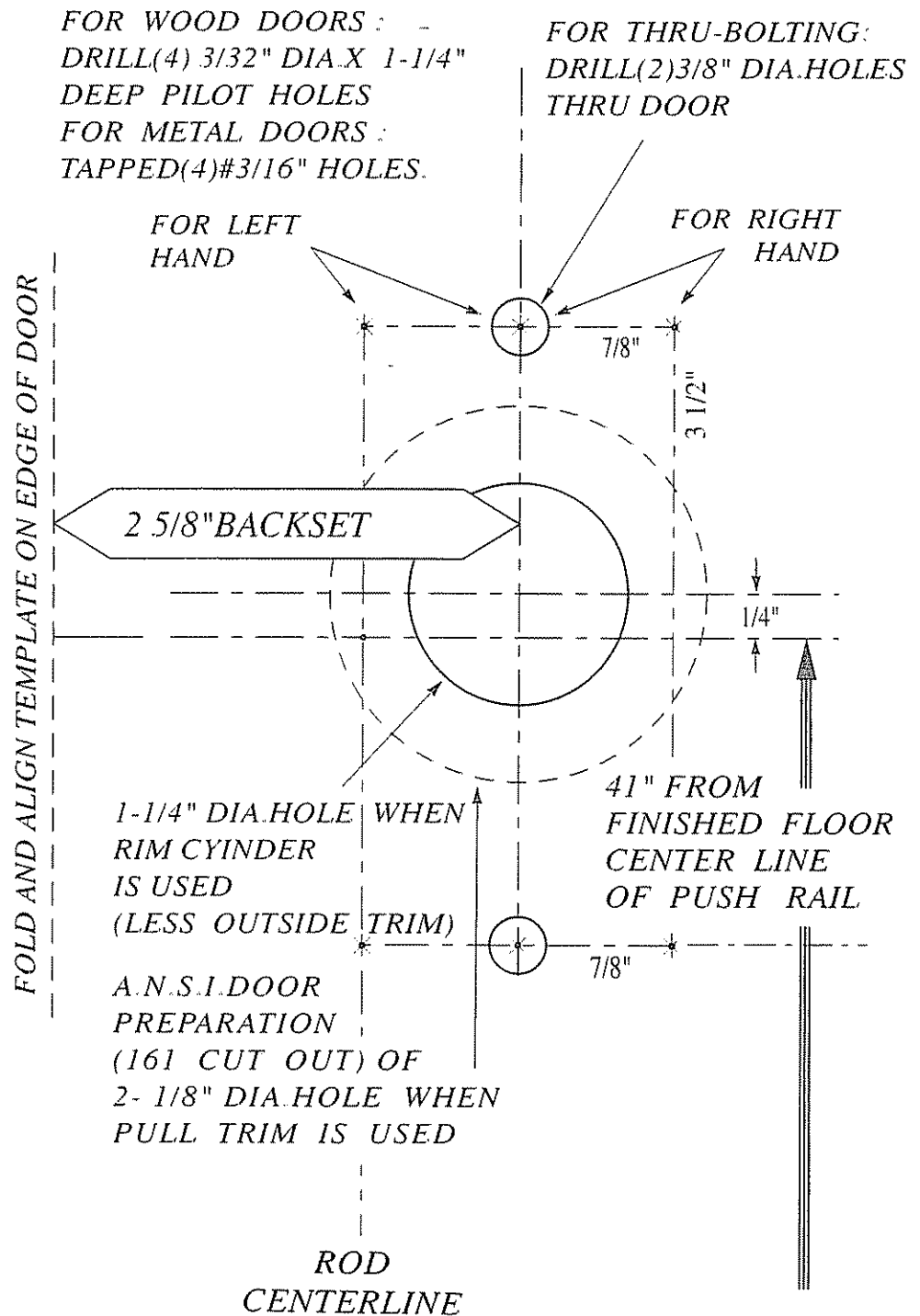

① FOR REFERENCE LINES REFER TO INSTRUCTION SHEET