

Assembly Instruction

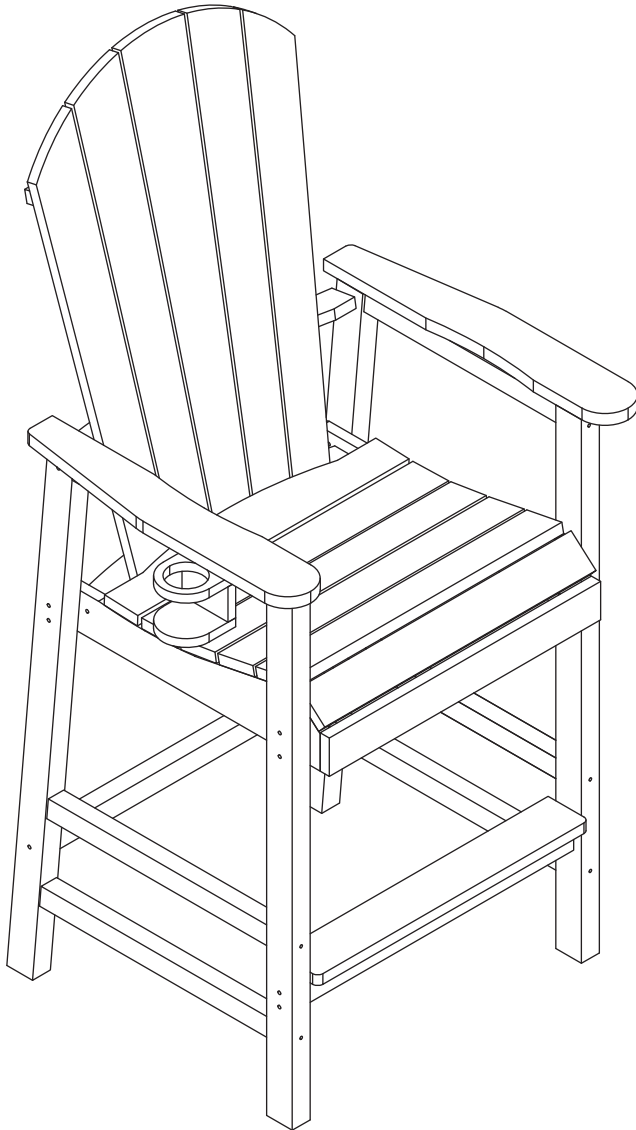







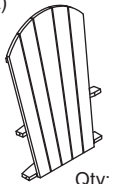
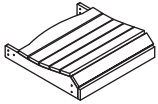
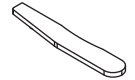
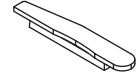

PRE-ASSEMBLY PREPARATION

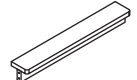

WARNING! DO NOT LET CHILDREN PLAY IN OR AROUND THE UNIT DUE TO THE POSSIBLE RISK OF FINGER ENTRAPMENT

- Please read through this instruction before beginning assembly.
- Two adults assembly is recommended.
- Clear out the space for assembly and lay out all parts base on Parts List, extra room will allow you to easily determine if all the pieces are present.
- Save all packing materials until assembly is complete to avoid accidentally discarding smaller parts or hardware.
- Keep small parts and pieces away from children until fully assembly.
- **Do not fully tighten the bolts until all have been inserted and hand tightened.**
- Please check for any loose screws and tighten them before use.

PANEL AND FITTINGS IDENTIFICATION

(A)  Qty: 1	(B)  Qty: 1	(C)  Qty: 1	(D)  Qty: 1	(E)  Qty: 2	(F)  Qty: 2
(G)  Qty: 2	(H)  Qty: 2	(I)  Qty: 1	(J)  Qty: 1	(K)  Qty: 1	

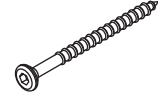
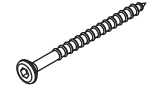
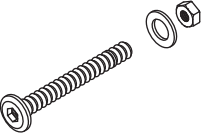
HARDWARE LIST

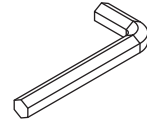
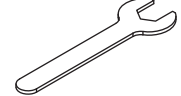
Screw (1)  M6 x 80mm Qty: 12	Screw (2)  M6 x 70mm Qty: 8	Screw (3)  M6 x 55mm Qty: 2	Bolt (4)  M6 x 60mm Qty: 8
Bolt (5)  M6 x 30mm Qty: 1	Allen Wrench (6)  Qty: 1	Open End Wrench (7)  Qty: 1	

Step 1

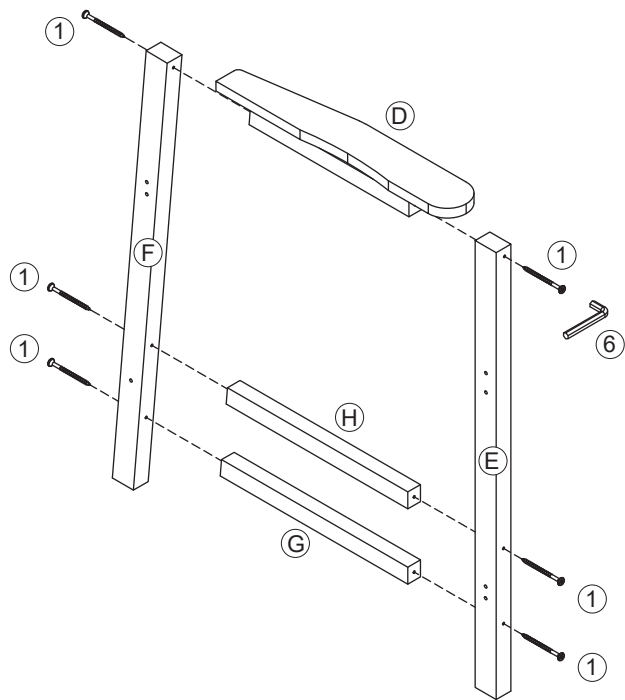

- D=1PC
- E=1PC
- F=1PC
- G=1PC
- H=1PC
- 1=6PCS
- 6=1PC

Step 2

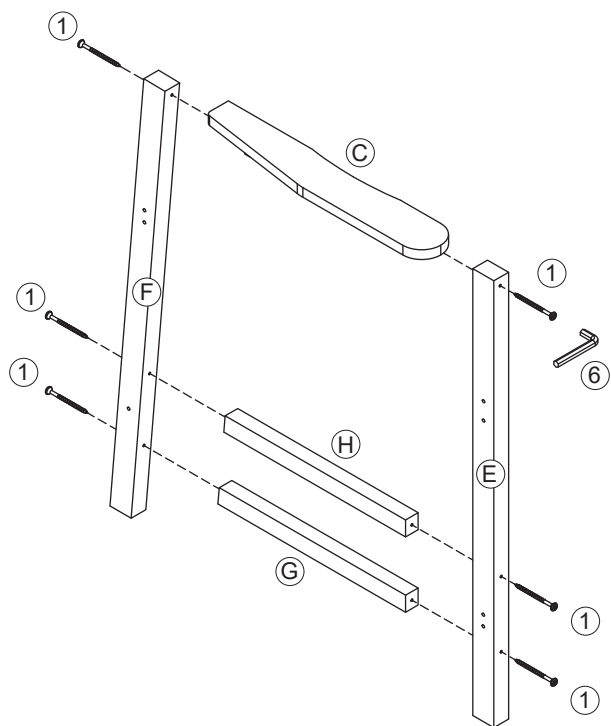

- C=1PC
- E=1PC
- F=1PC
- G=1PC
- H=1PC
- 1=6PCS
- 6=1PC

Step 3

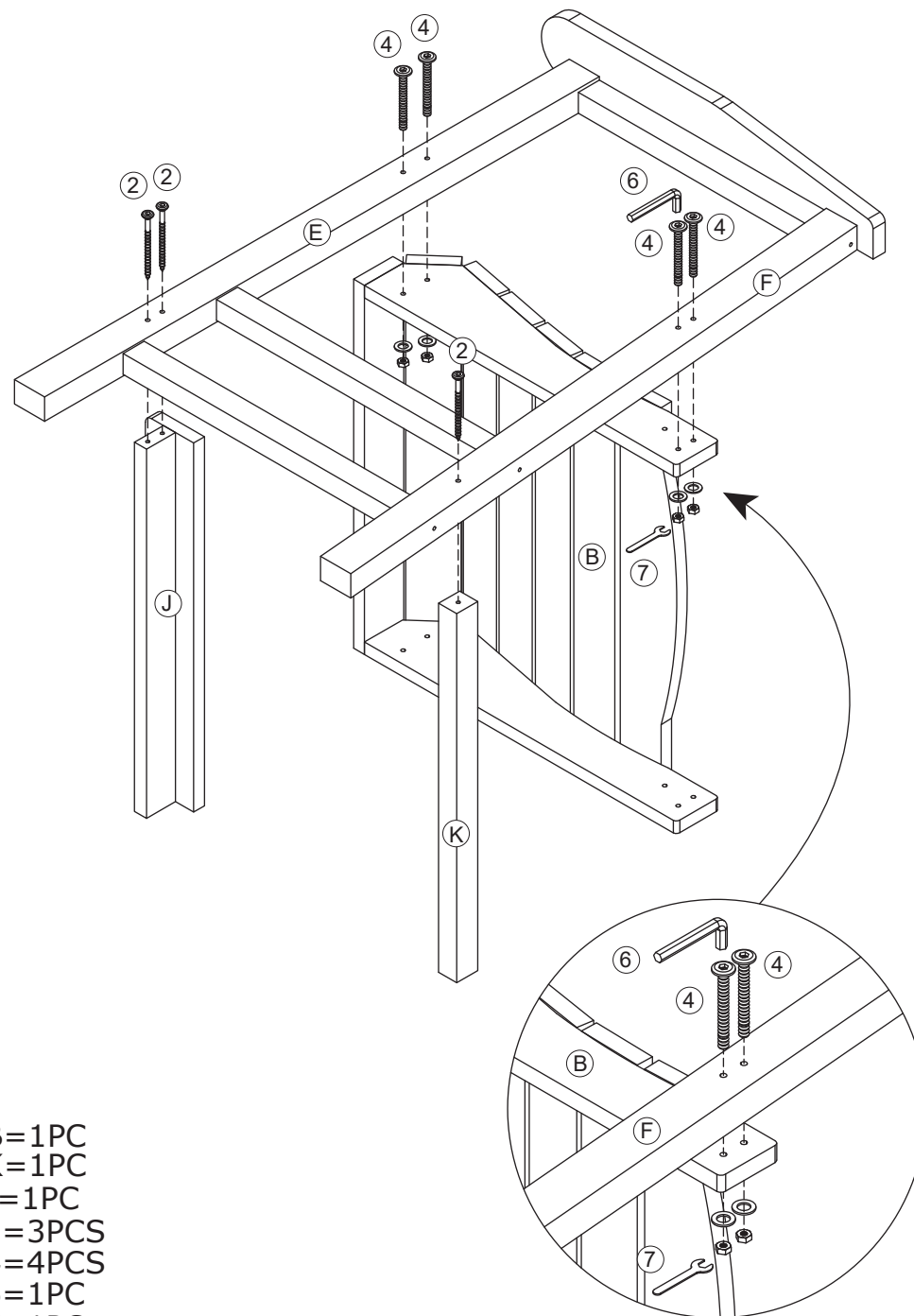

- B=1PC
- K=1PC
- J=1PC
- 2=3PCS
- 4=4PCS
- 6=1PC
- 7=1PC

Step 5

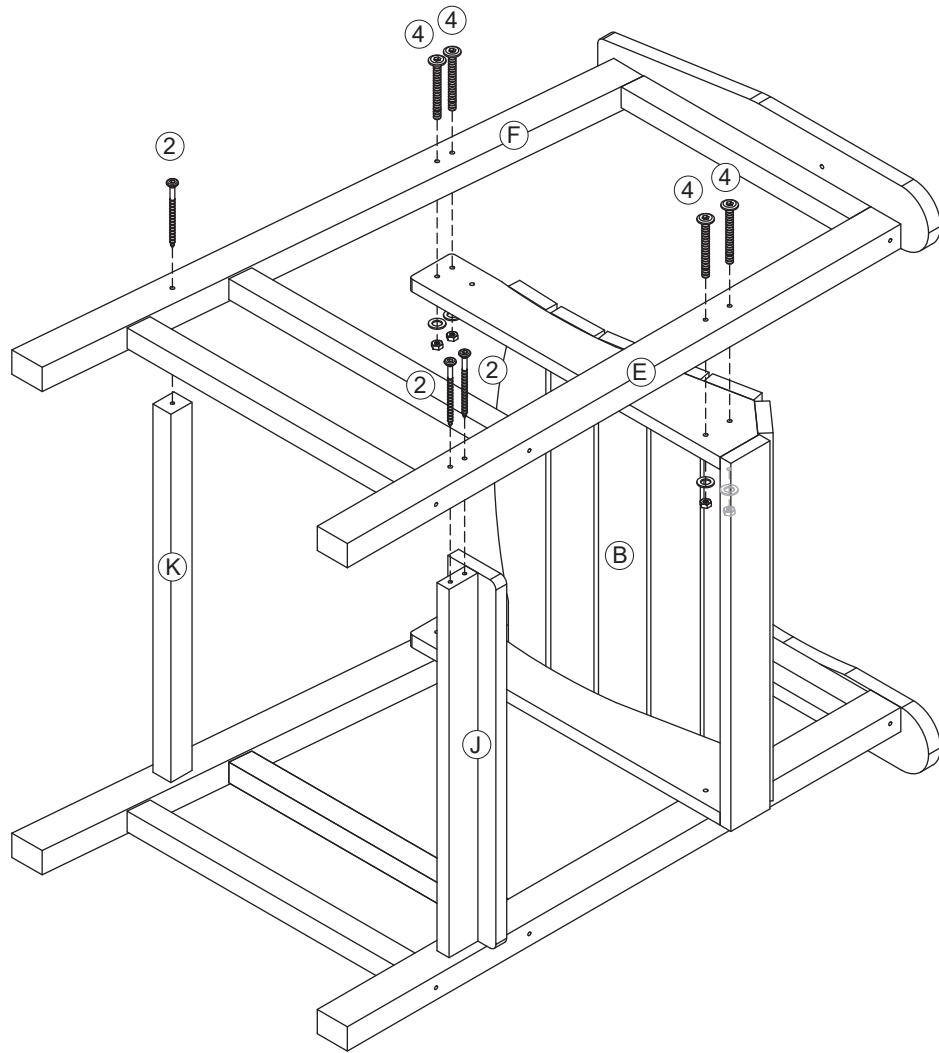

2=3PCS
4=4PCS

Ten End

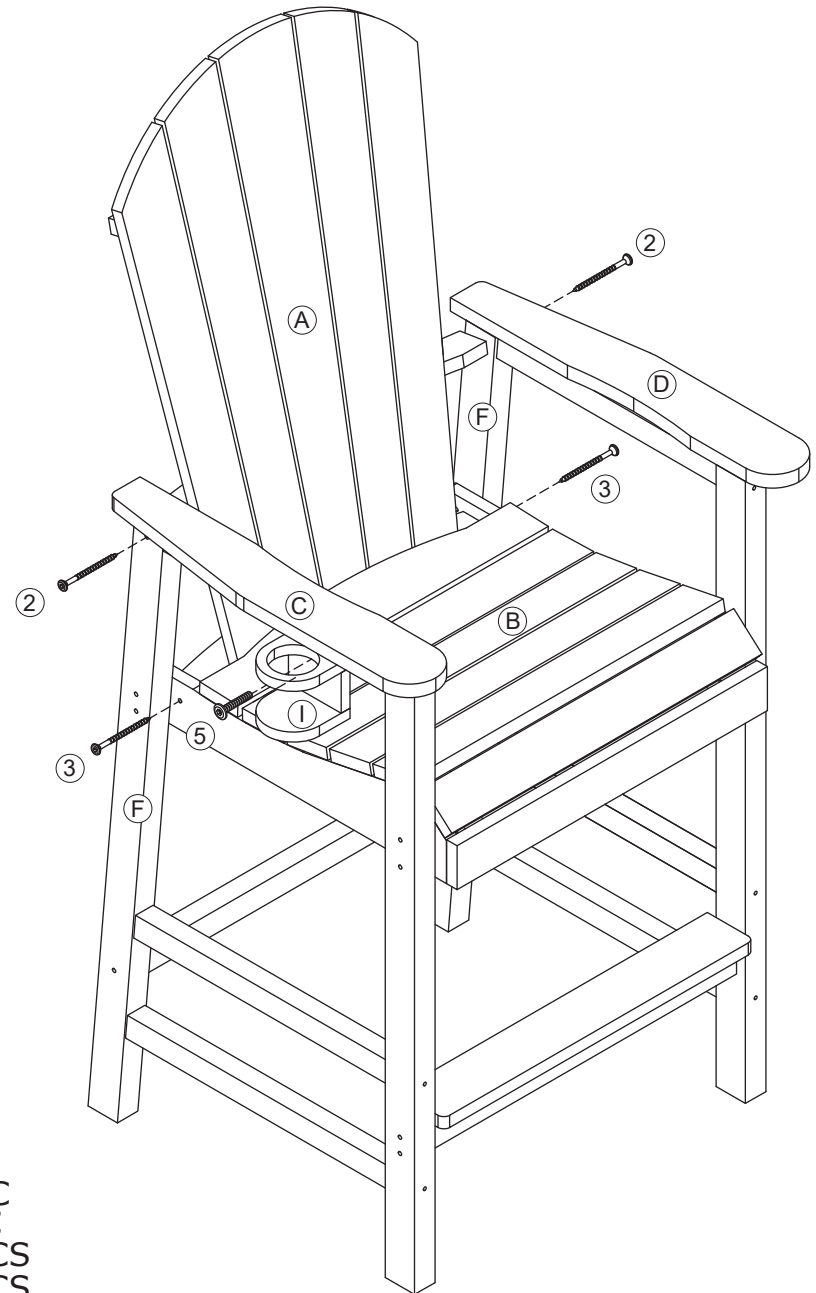

A=1PC
I=1PC
2=2PCS
3=2PCS
5=1PC