

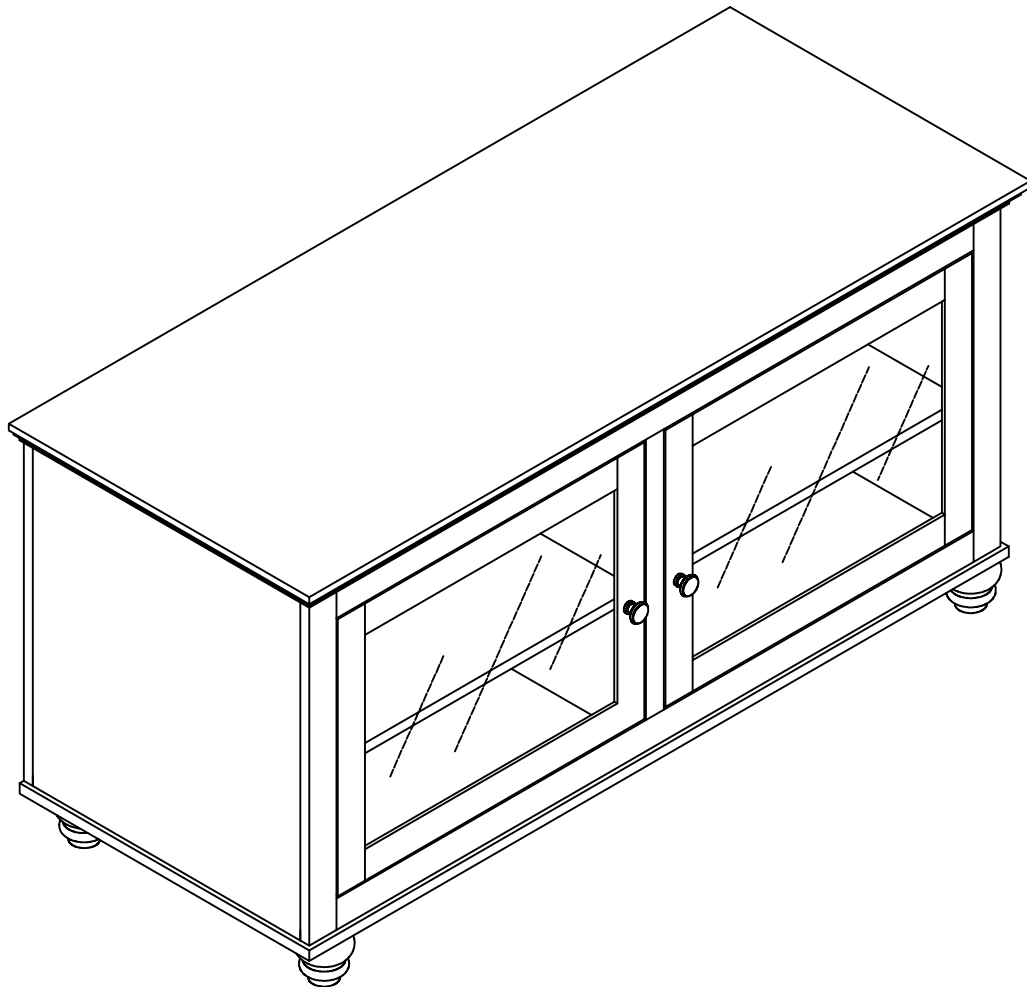

# ASSEMBLY INSTRUCTION

## 93012A

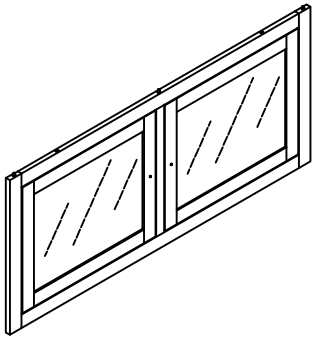
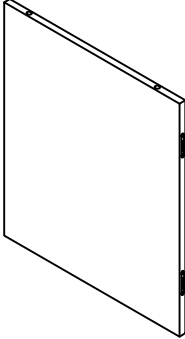
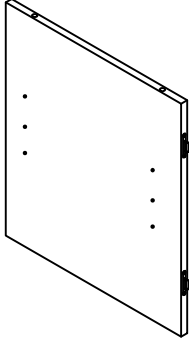
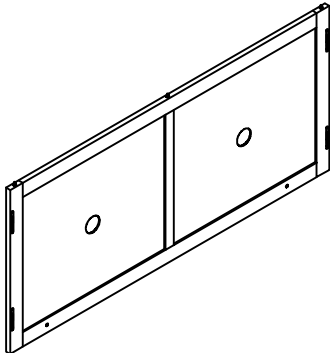
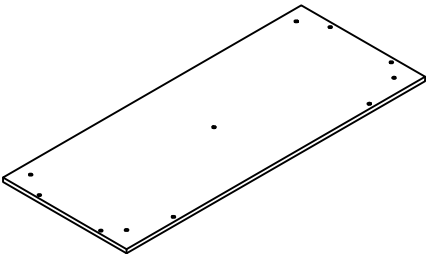
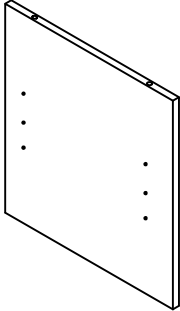

**NO TOOLS..**

# PARTS LIST

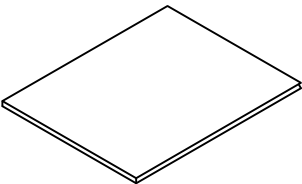
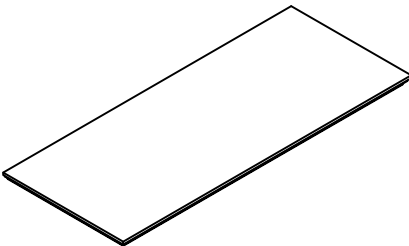
1	FRONT FRAME	1 PC	2	LEFT SIDE PANEL	1 PC	3	RIGHT SIDE PANEL	1 PC
								
4	BACK FRAME	1 PC	5	BOTTOM PANEL	1 PC	6	DIVIDER	1 PC
								
7	LEG	1 PC	8	FOOT	4 PCS	9	LOOSE SHELF	2 PCS
								
10	TOP PANEL	1 PC						
								

# HARDWARE LIST

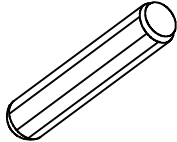
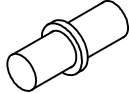
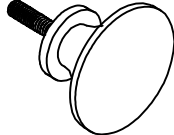
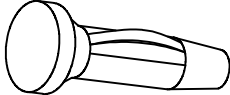
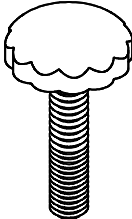
A	WOODEN DOWEL	2 PCS	B	SHELF PIN	8 PCS	C/D	KNOB/BOLT	2 PCS
						 The Screw is inside the knob		
E	INSERT PIN	4 PCS	F	THUMB SCREW	4 PCS			
								

	<b>LUBRICANT NOT PROVIDED</b>  We recommend the use of a lubricant on the key locks for easier assembly. This will allow the hardware to slide together with greater ease. We suggest the use of vaseline or liquid soap as a lubricant. Please be sure to wipe the surfaces clean after the assembly to prevent damage to the board.
---	---

If any parts are missing or damaged in this package, circle the item(s) needed to the left on the parts or hardware list. Please be sure to have the model # and color ready when ordering parts.

You can contact us by mail:

Premier RTA

4105 McMinnville Hwy

Sparta, TN 38583

Or fax: (931) 657-5507

Or phone from 8:00A - 4:00P CST: 1-866-782-0515

Or e-mail: [parts@blomand.net](mailto:parts@blomand.net)

NAME:		
ADDRESS:		
CITY:	STATE:	ZIP CODE:
HOME PHONE:	WORK PHONE:	

# Step 1

- For easier assembly, apply a small drop of lubricant (not provided) on each fitting before attaching.
- NOTE: See Hardware Page for suggested lubricants.
- Align the Left Side Panel (#2) fittings with the Front Panel (#1) fittings; push down on the Side Panel to lock into place.
- NOTE: See illustration before sliding parts into place, note the board position.
- Repeat for the Right Side Panel (#3).

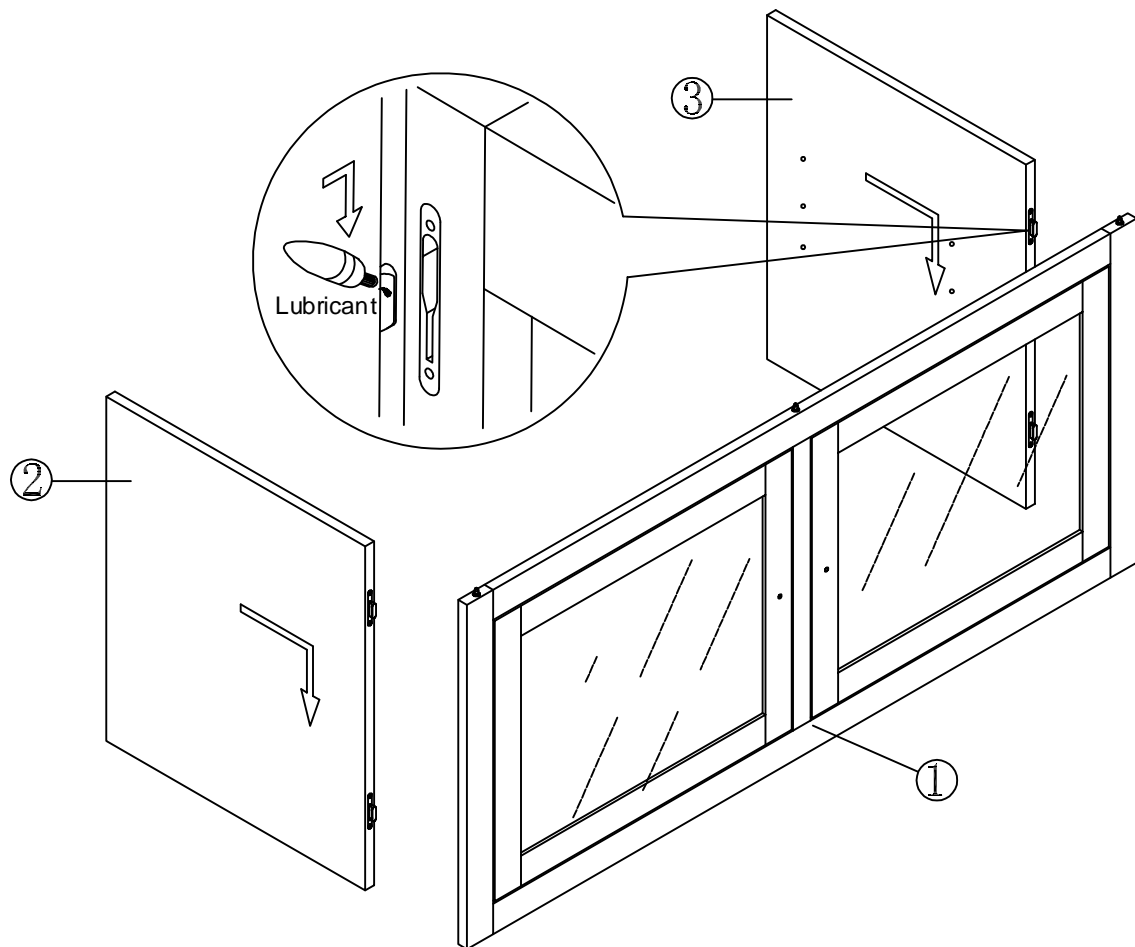

## Step 2

- Apply a small drop of lubricant (not provided) on each fitting before attaching.
- NOTE: See Hardware Page for suggested lubricants.
- Align the Back Panel (#4) fittings with the Side Panel fittings; push down on the Side Panels to lock into place.
- NOTE: See illustration before sliding parts into place, note the board position.

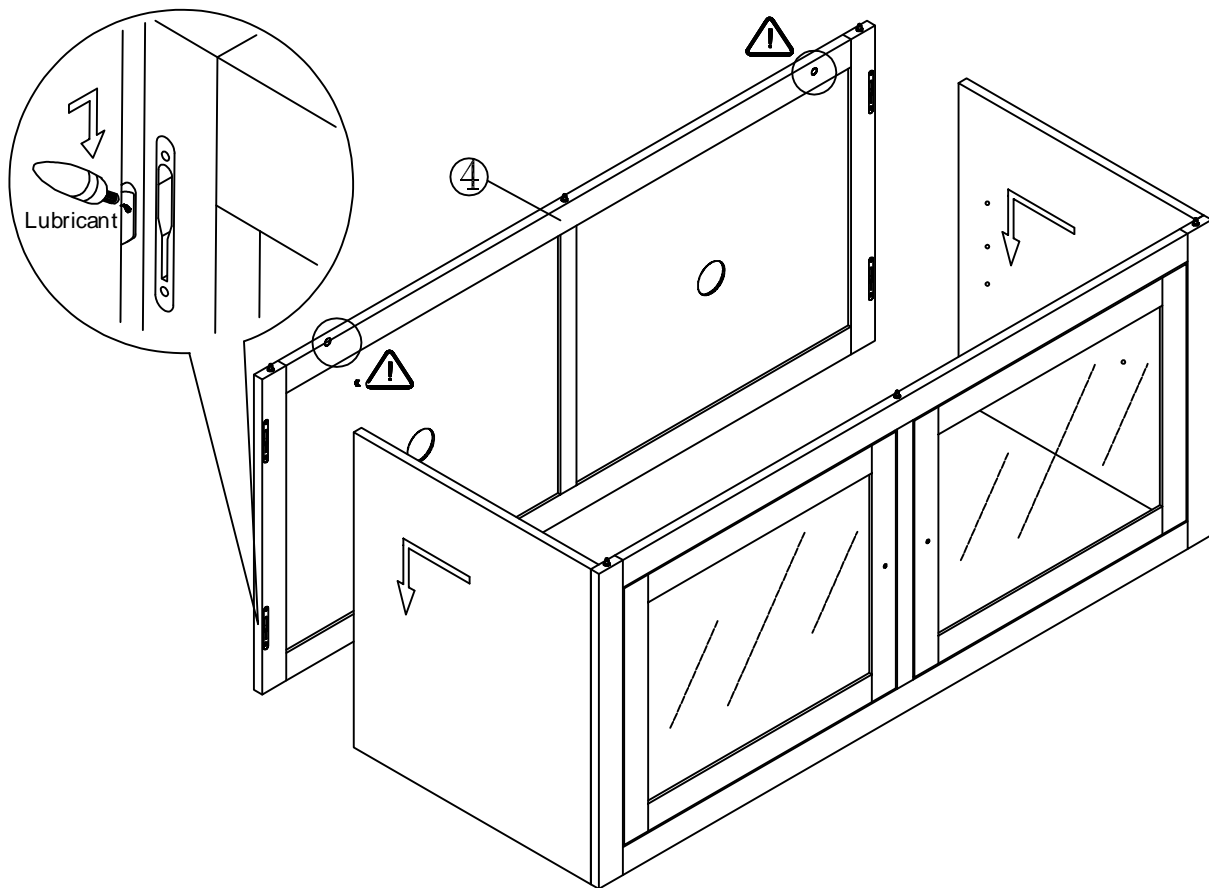

## Step 3

- Set the Bottom Panel (#5) face up on the floor.
- Carefully lift Front Frame/Left Side Panel/Right Side Panel/Back Frame assembly onto Bottom Panel.
- Align pins, push down on all panels to lock into place.

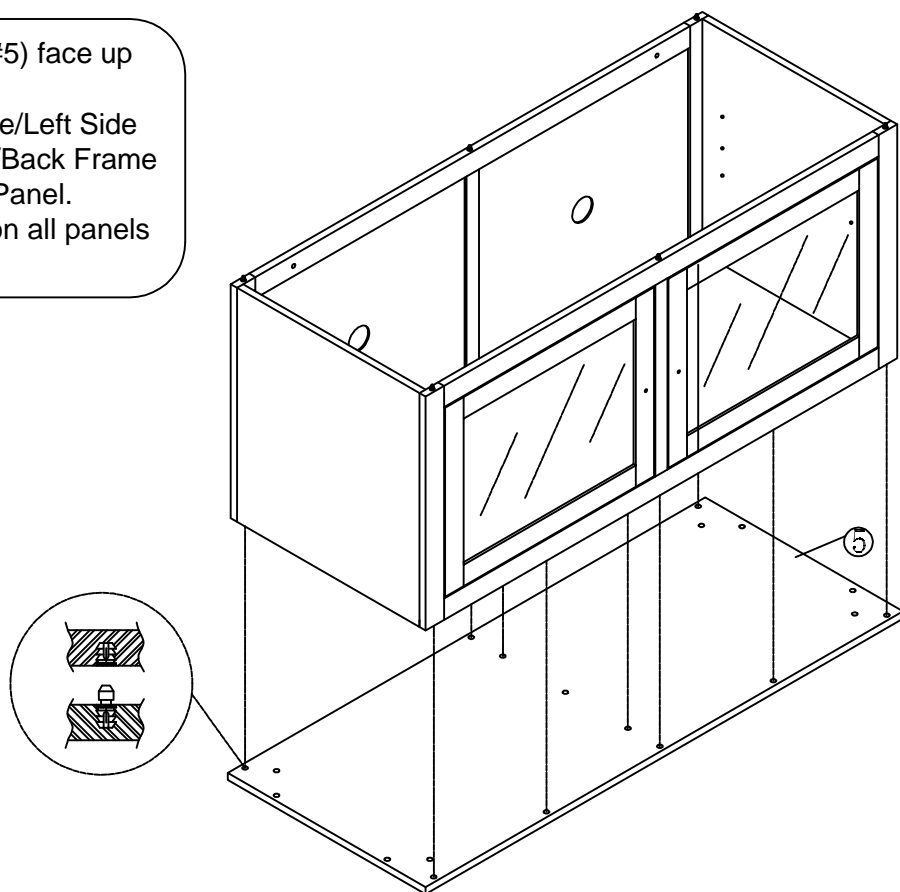

## Step 4

- Align and slide the Divider (#6) into place.
- Push down to snap into place.
- NOTE: There are 2 pins in the bottom of the Divider.

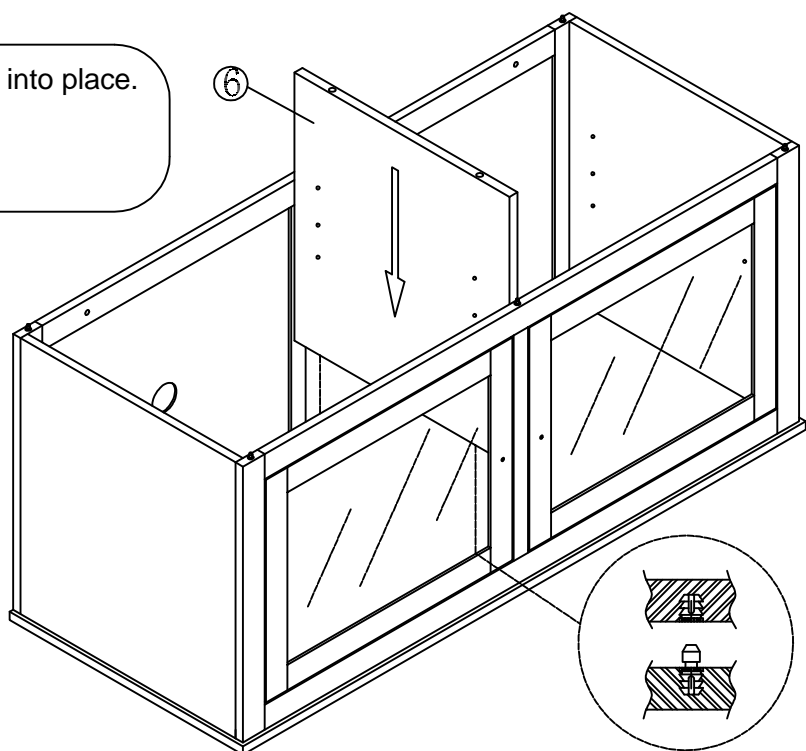

## Step 5



- Carefully tip the unit over.
- Thread 4 Thumb Screws (F) into Bottom Panel (#5).
- Thread 4 Feet (#7) into Bottom Panel (#5).
- Thread Leg (#7) through Bottom Panel and into Divider.

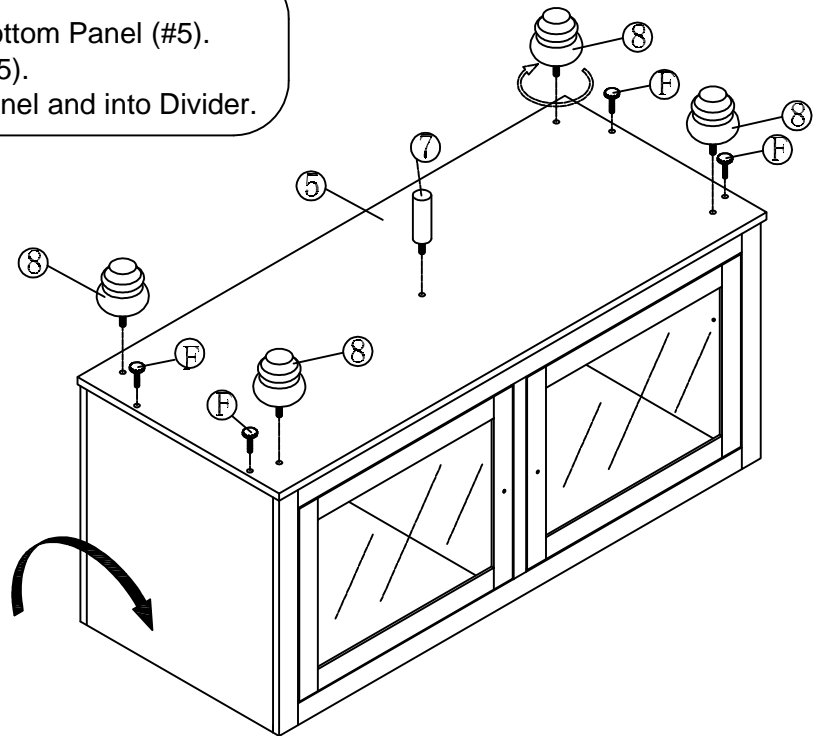

## Step 6

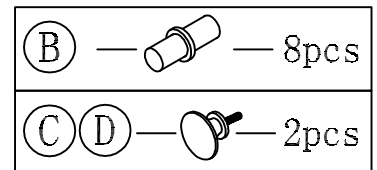

- Carefully tilt unit back onto the feet.
- Insert Shelf Pins (B) into Side Panels and Divider at the desired height.
- Slide Loose Shelves (#9) onto Shelf Pins.
- NOTE: It may be necessary to tilt the Loose Shelves (#7) to slide into place.
- Attach 1 knob/screw (C/D) to each Door.

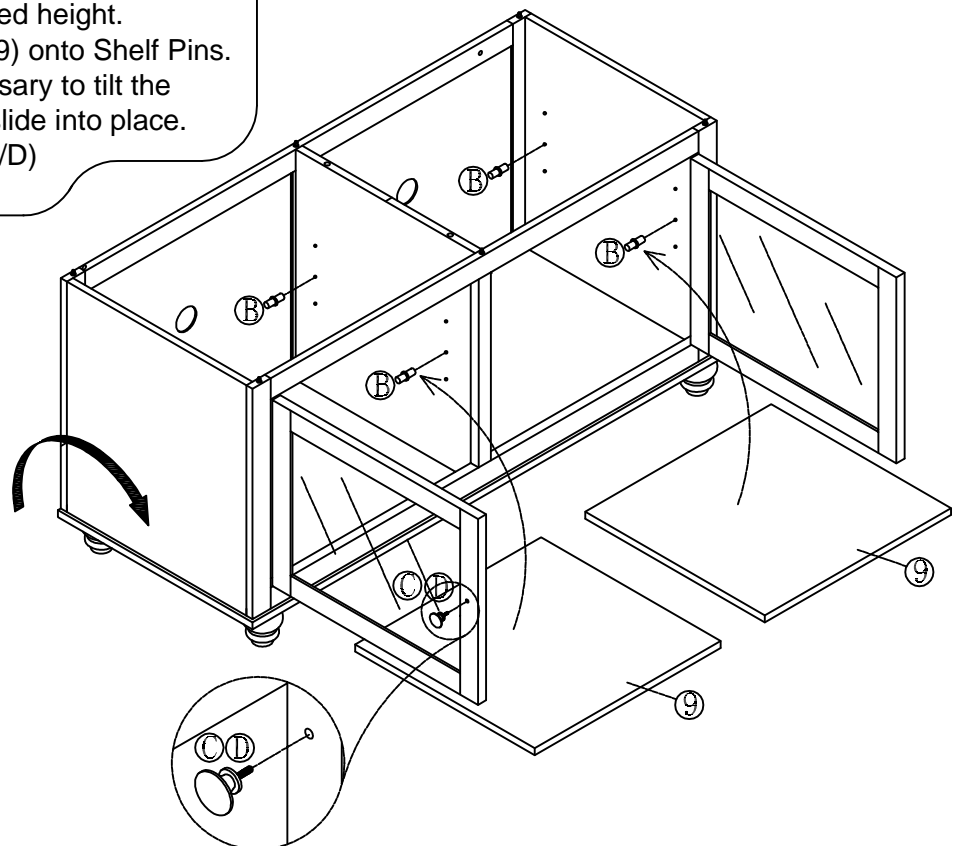

# Step 7

- Insert 2 Wooden Dowels (A) into the top of the Divider.
- Align the Top Panel (#10) with the pins on the main unit.
- Open doors.
- Push the Plastic Insert Pins (E) into the blocks located on the Top Panel. (See diagrams below)

