



























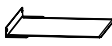



























No.	#	QTY / CANT. / QTÉ	Description / Descripción / Description	Image / Imagen / Image
1	EZJ10DB03-RGC	1	Bottom shelf Estante inferior Étagère inférieure	
2	AJQPGDZ01	1	Screw bushing Buje del perno de fijación de la bombona Douille de vis	
3	07-QPG-05-SI	1	LP cylinder screw Perno de fijación de la bombona Vis de bouteille de gaz	
4	05-WXL-06	2	Caster Rueda Roulette	
5	EZJ10JGRF02H	1	Right front leg Pata delantera derecha Jambe avant droite	
6	EZJ10JGRB02H	1	Right back leg Pata trasera derecha Jambe arrière droite	
7	EZJ10JGLF02	1	Left front leg Pata delantera izquierda Jambe avant gauche	
8	EZJ10JGLB02	1	Left back leg Pata trasera izquierda Jambe arrière gauche	
9	05-SLL-27-BK	2	Wheel Rueda Roue	
10	06-XZL-1-21-DY	1	Wheel axle Eje de las ruedas Axe de roue	
11	EZJ10QZCB	1	Cabinet center stile Viga central del armario Poutre centrale de l'armoire	
12	EZJ10QXDB	1	Front panel Panel frontal Panneau avant	
13	EZJ10QGL	1	Front basket Cesta frontal Panier avant	
14	EZJ10ZGBZC	1	Shelf support Soporte del estante Support d'étagère	
15	EZJ10ZGB	1	Upper shelf Estante superior Étagère supérieure	
16	EZJ10HHL02H	1	Cart front beam Barra frontal del carro Poutre avant du chariot	
17	EZJ10LTGDB	2	Main body support beam Barra de soporte del cuerpo principal Poutre de support du corps principal	
18	EL5JPGJ	1	Cooking griddle hook Gancho para plancha de cocción Crochet de grille de cuisson	
19	EZJ10QPGRB01-RGC-DS1	1	Thermal baffle Deflector térmico Panneau isolant	

No.	#	QTY / CANT. / QTÉ	Description / Descripción / Description	Image / Imagen / Image
20	EZJ10HHL02H	1	Cart rear beam Viga trasera del carro Traverse arrière du chariot	
21		1	Main body Cuerpo principal Corps principal	
22	EJLTGDBL02	1	Main body bracket (L) Soporte del cuerpo principal (I) Support principal du corps (G)	
23	EJLTGDBR02	1	Main body bracket (R) Soporte del cuerpo principal (D) Support principal du corps (D)	
24	EB00-L	1	Side burner shelf Base del quemador lateral Étagère du bruleur d'appoint	
25	EB00-R	1	Side shelf Bandeja lateral Étagère latérale	
26	06-XNZ-5-01	1	Knob base Base de mando de regulación de llama Base du bouton	
27	06-XNL-5-17ABK-PDD1-PBK-RGC	6	Knob Mando de regulación de llama Bouton	
28	01-LTL-4-08-245-SS4	1	Side burner Quemador lateral Bruleur d'appoint	
29	ELJYP023B	1	Grease tray Bandeja de recogida de grasa Lèche-frite	
30	ELYBZJL02	1	Grease cup bracket (L) Fijación de depósito de recogida de grasa (I) Support du bac à graisse (G)	
31	ELYBZJR02	1	Grease cup bracket (R) Fijación de depósito de recogida de grasa (D) Support du bac à graisse (D)	
32	ELYB02-LS4	1	Grease cup Depósito de recogida de grasa Bac à graisse	
33	ELFHB02	3	Flame tamer Regulador de llama Atténuateur de flamme	
34	03-XKW-E-02-TC3	1	Larger cooking grate Rejilla de cocción más grande Grille de cuisson plus grande	
35	03-XKW-E-01-TC3	1	Cooking grate Rejilla para asar Grille de cuisson	
36	ELBWW013B-SS4	1	Warming rack Rejilla para calentar Grille de réchauffement	
37	06-WDJ-3-03	1	Thermometer Termómetro Thermomètre	
38		1	Pizza oven Horno para pizza Four à pizza	

No.	#	QTY / CANT. / QTÉ	Description / Descripción / Description	Image / Imagen / Image
39	TY-KPQ01-SS4	1	Bottle opener Abridor de botella Ouvre-bouteille	
40	Z-51130007	1	Side burner decoration board Panel decorativo del quemador lateral Panneau de décoration du bruleur d'appoint	
41	Z-51130002	1	Side shelf decoration board Panel decorativo de la bandeja lateral Panneau décoration de la étagère latérale	

Key / Clave / Réf.	Description / Descripción / Description	QTY / CANT. / QTÉ	Image / Imagen / Image
A	M5×55	20	
B	M5×10	41	
C	M5×10(SS)	4	
D	Washer Arandela Rondelle	1	
E	M5	6	
F	Pad Arandela Tampon	2	
G	Split pin Pasador partido Goupille fendue	1	
H	M5×20	2	
I	M4×8	6	
J	M4×8	4	
K	Knurled thumb screw Tornillo moleteado de mariposa Vis moletée à main	2	
L	M6×15	2	

TOOLS REQUIRED / HERRAMIENTAS REQUERIDAS / OUTILS REQUIS		
Phillips screwdriver Destornillador phillips Tournevis phillips	Wrench Llave Clé	

Before beginning assembly, make sure all parts are present. If any parts are missing or damaged, do not attempt to assemble the products. Contact customer service for replacement parts via telephone or email.

- Tools needed (not included): Phillips screwdriver and wrench
- Approximate assembly time: 40 minutes
- Note: 1. The right and left sides of the grill are designed as if you are facing the front of the grill.
2. Model shown for illustration purpose only, specific please in kind prevail.

Antes de comenzar el montaje, asegúrese de que todas las piezas estén presentes. Si falta alguna pieza o está dañada, no intente ensamblar los productos. Póngase en contacto con el servicio de atención al cliente para obtener piezas de repuesto por teléfono o correo electrónico.

- Herramienta necesaria (no incluido): Destornillador phillips y llave
- Tiempo aproximado de ensamblaje: 40 minutos
- Nota: 1. Los lados derecho e izquierdo de la parrilla están diseñados como si estuvieras frente a la parte delantera de la parrilla.
2. El modelo que se muestra es sólo para fines ilustrativos, prevalecen los específicos en especie.

Avant de commencer l'assemblage, assurez-vous que toutes les pièces sont présentes. Si des pièces sont manquantes ou endommagées, n'essayez pas d'assembler les produits. Contactez le service de clientèle pour les pièces de rechange par téléphone ou par e-mail.

- Outils nécessaires (non inclus): Tournevis phillips et clé
- Temps nécessaire pour l'assemblage: 40 minutes
- Remarque: 1. les côtés droit et gauche du gril sont conçus comme si vous faisiez face à l'avant du gril.
2. le modèle est présenté à des fins d'illustration uniquement, spécifiques en nature prévalent.

1 L  x2

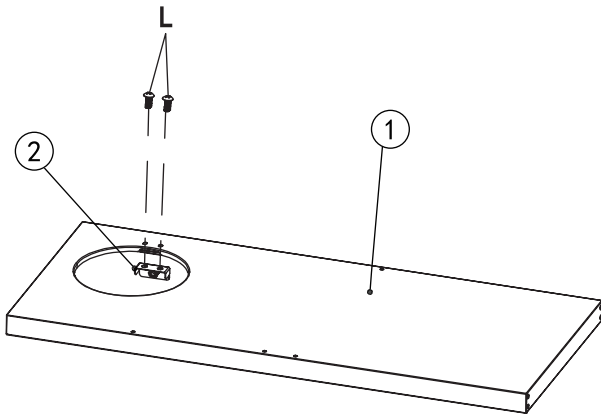

2 • Use the pre-installed screws from the LP cylinder screw.
• Utilice los tornillos preinstalados del tornillo del cilindro GLP.
• Utilisez les vis pré-installées de la bonbonne de gaz LP.

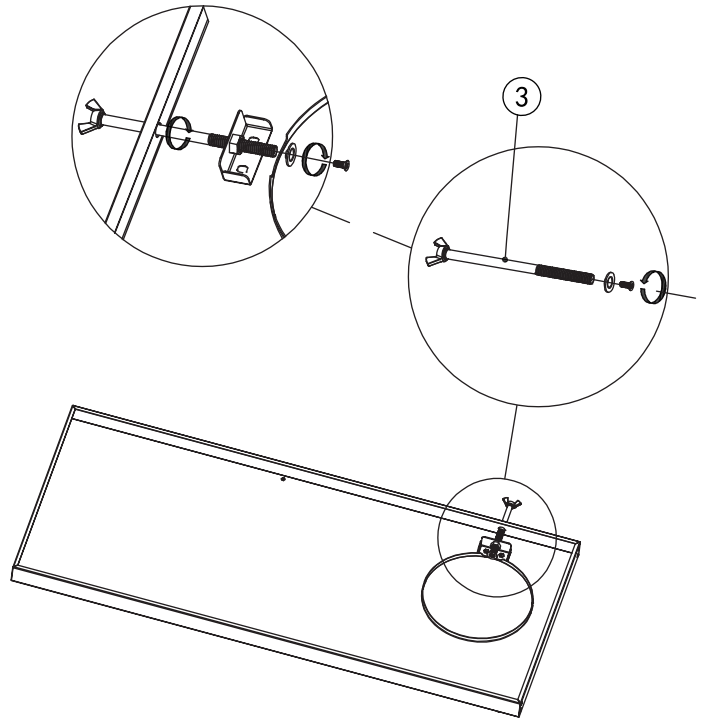

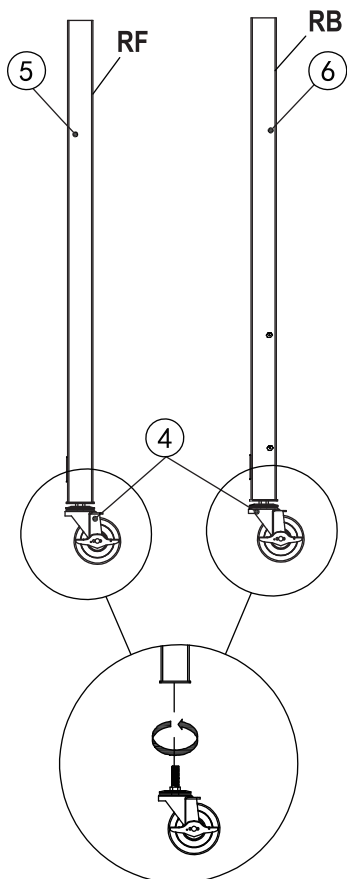

3



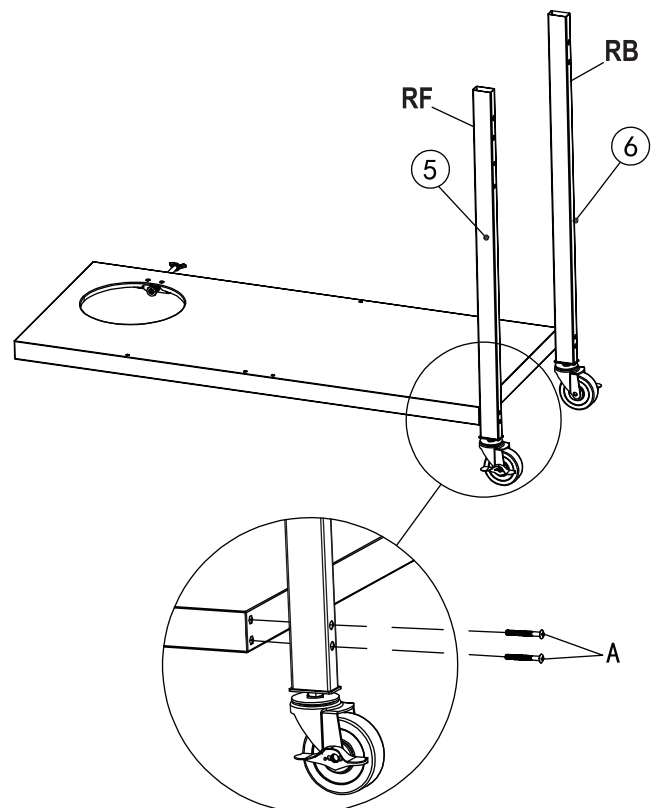

4 A  x4

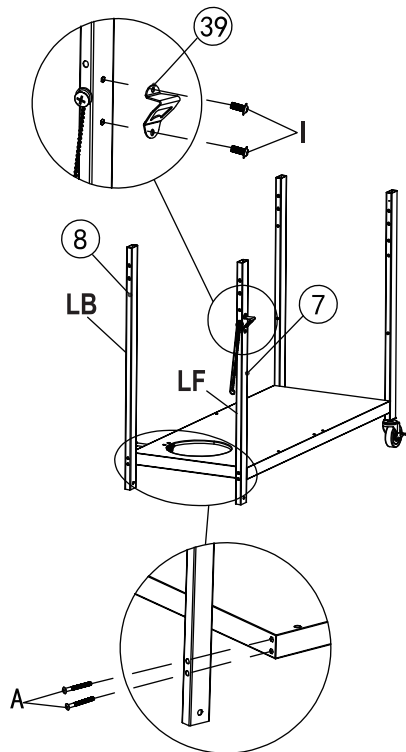

5	A		x4
	I		x2



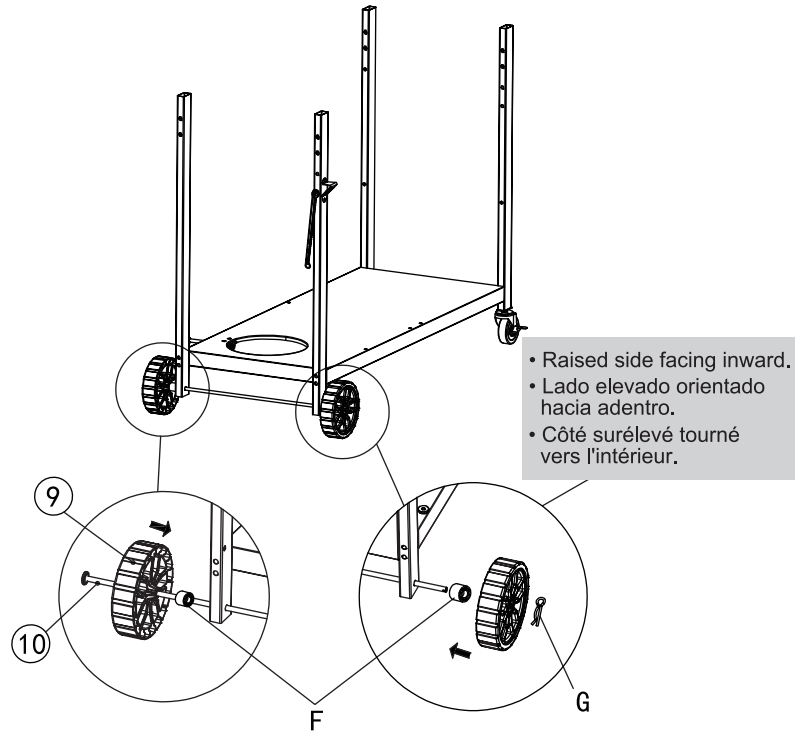

6	G		x1
	F		x2

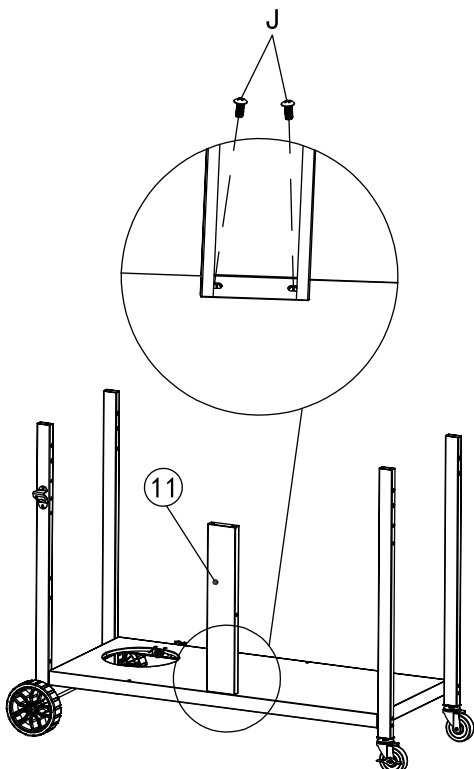

7	J		x2
----------	---	---	----



8	J		x1
	B		x4

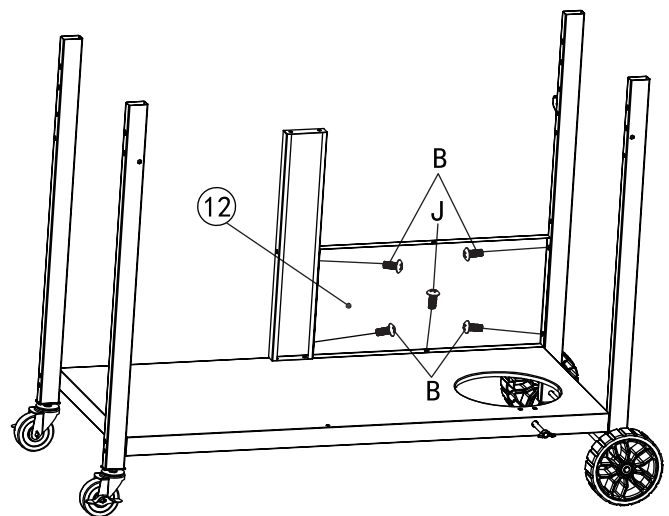

9 B  ⊕ ×5

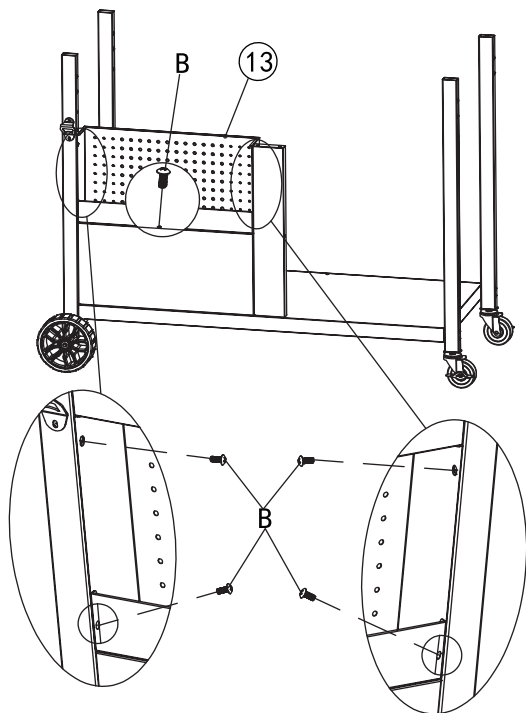

10 B  ⊕ ×2

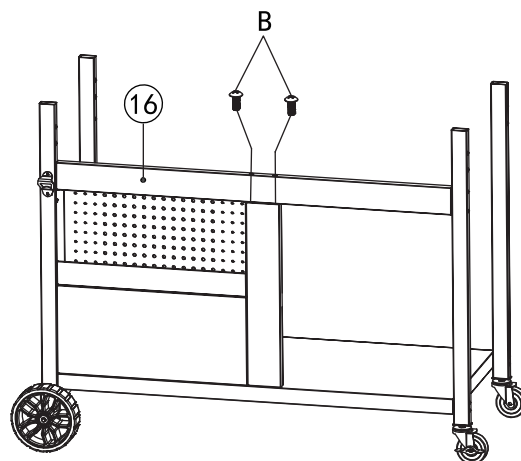

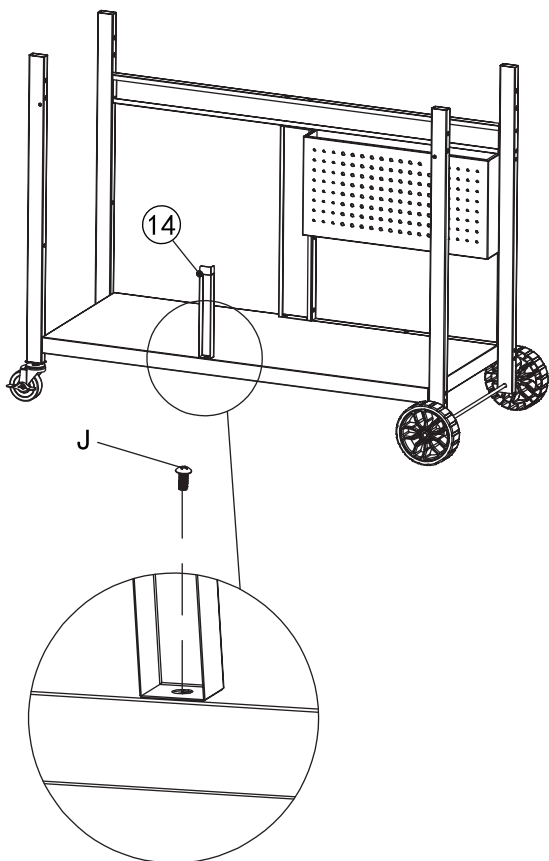

11 J  ⊕ ×1

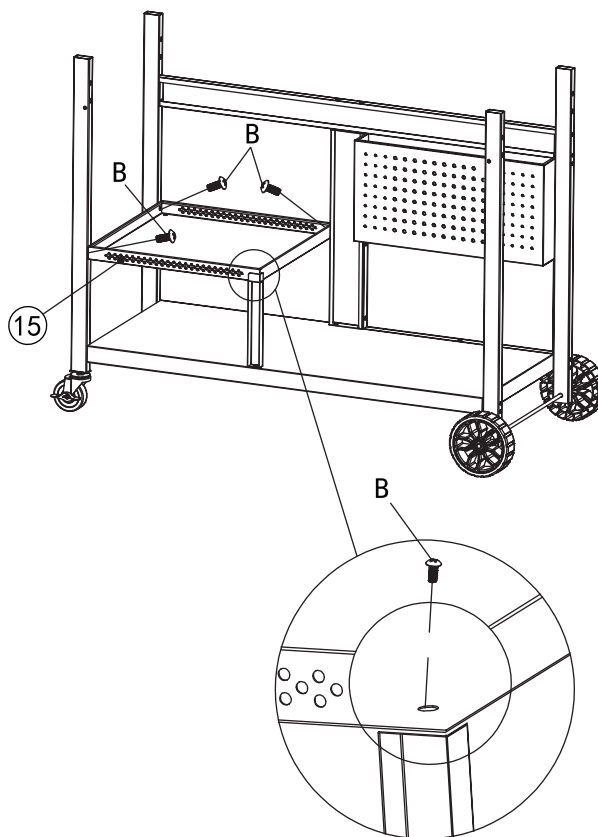

12 B  ⊕ ×4



13	A		×4
	B		×2

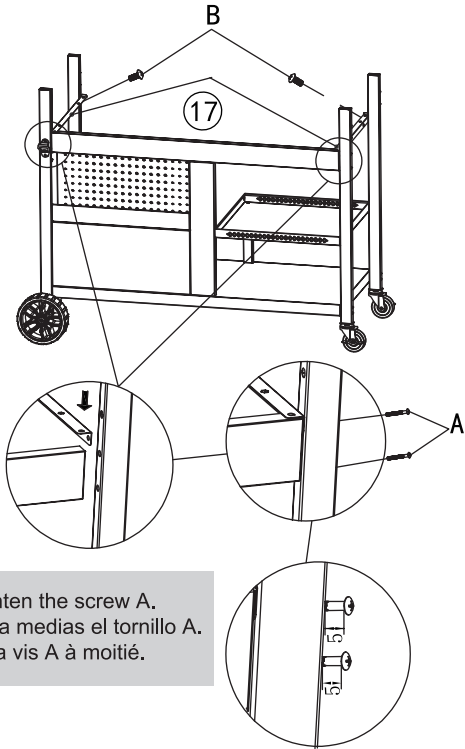

- Half tighten the screw A.
- Apriete a medias el tornillo A.
- Serrer la vis A à moitié.

14	B		×2
-----------	---	--	----

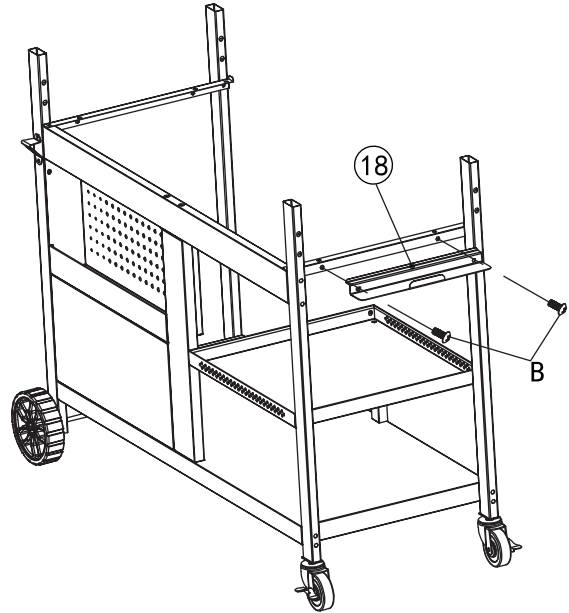

15	B		×2
-----------	---	---	----

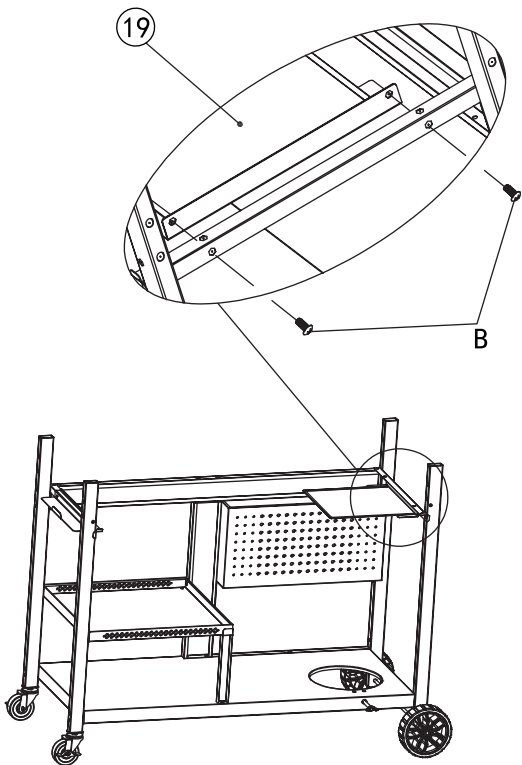

16	H		×2
-----------	---	--	----

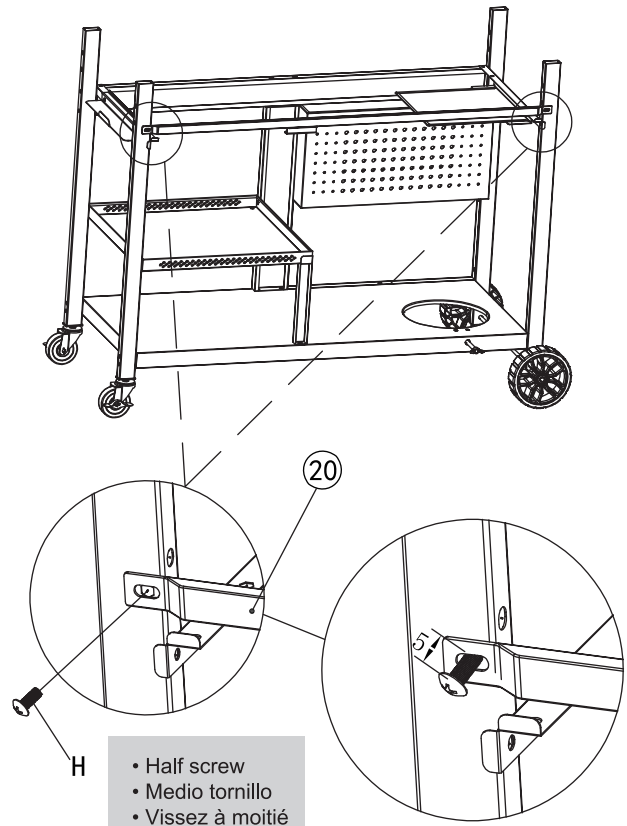

- Half screw
- Medio tornillo
- Vissez à moitié

17 B  ×4

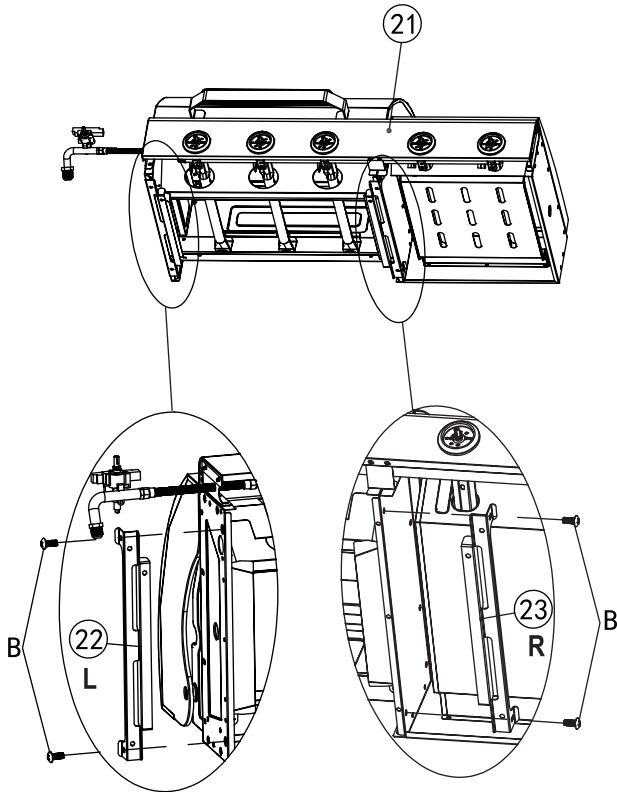

18 A  ×4

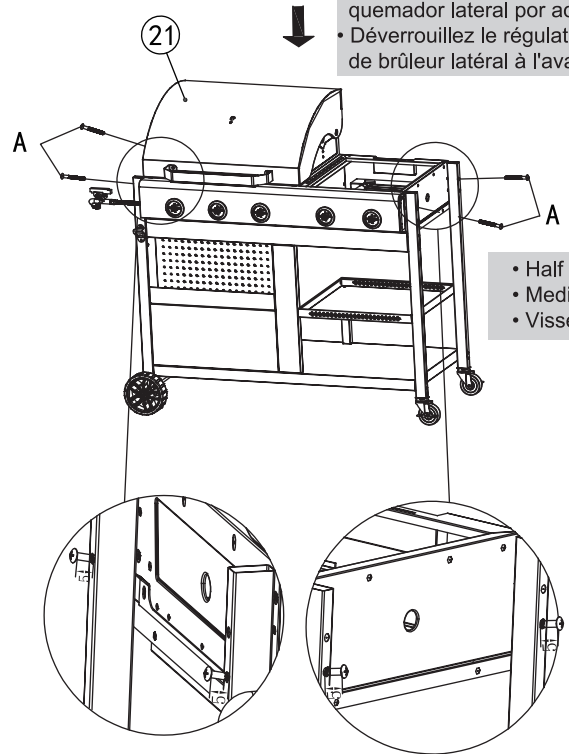

• Release the regulator and side burner valve in advance.
• Libere el el regulador y válvula del quemador lateral por adelantado.
• Déverrouillez le régulateur et valve de brûleur latéral à l'avance.

• Half screw
• Medio tornillo
• Vissez à moitié

19 B  ×4

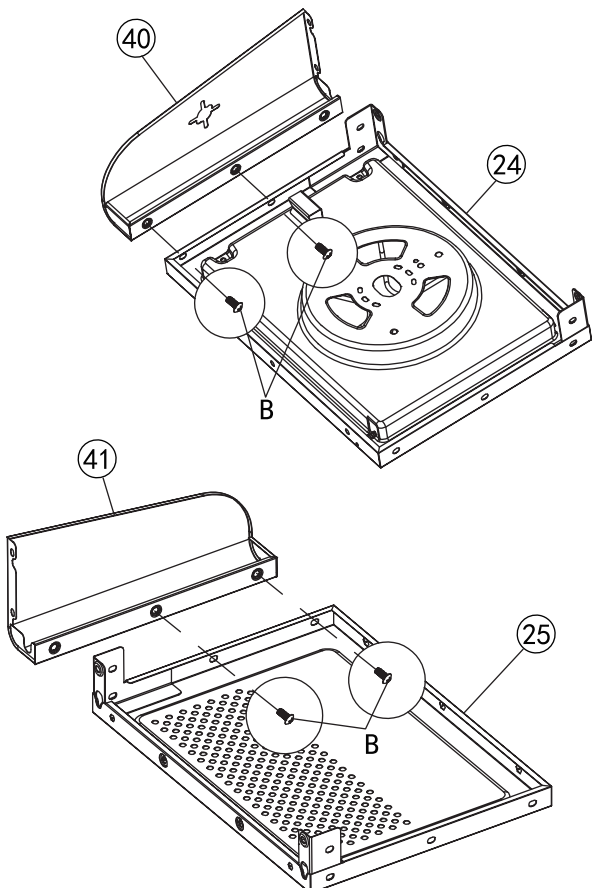

20 E  ×6

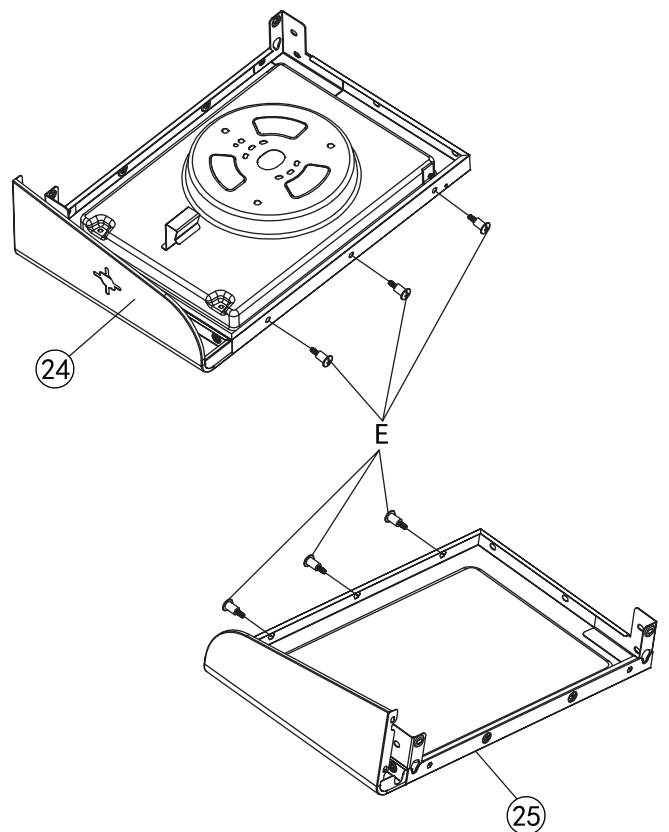

21 A  x4

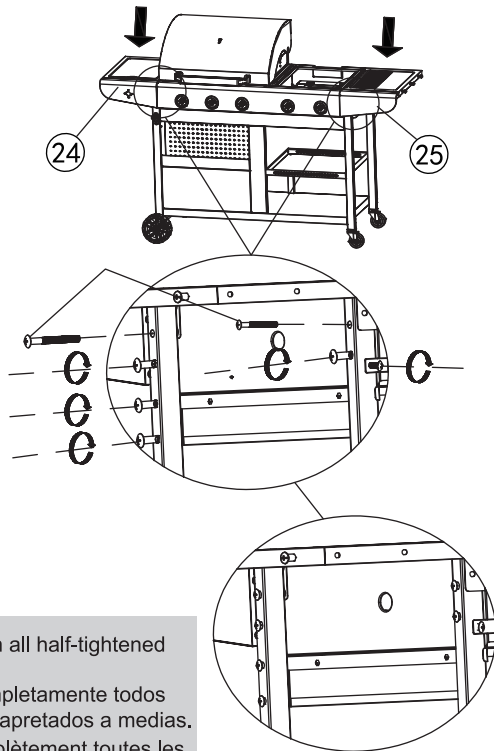

- Fully tighten all half-tightened screws.
- Apriete completamente todos los tornillos apretados a medias.
- Serrer complètement toutes les vis semi-serrées.

22 B  x4

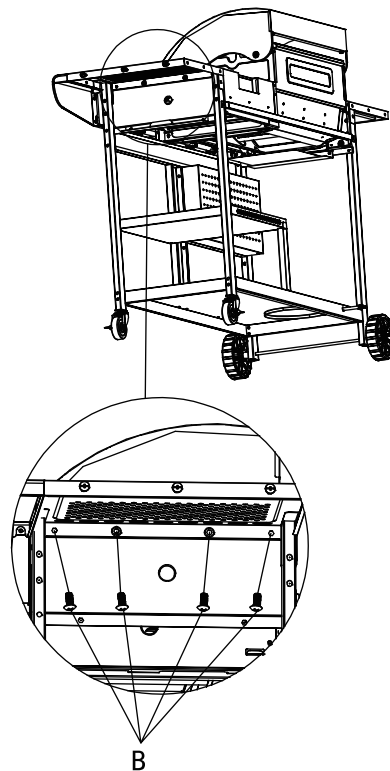

23 B  x4

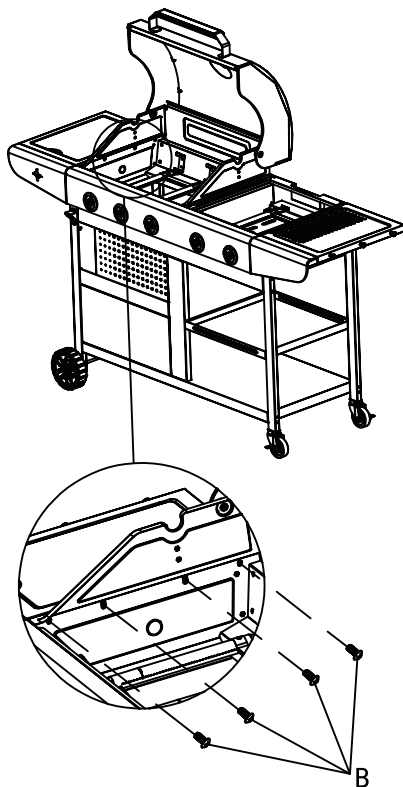

24 B  x4

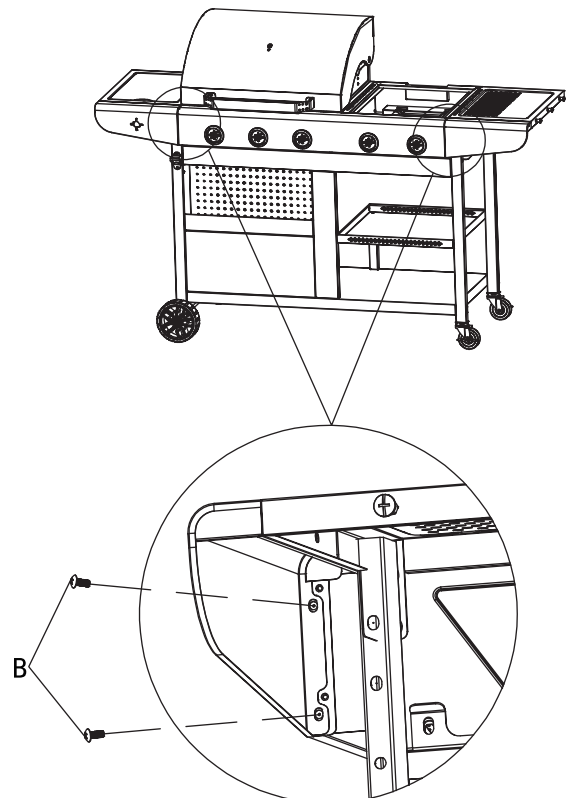

25 | 1 |  | x2

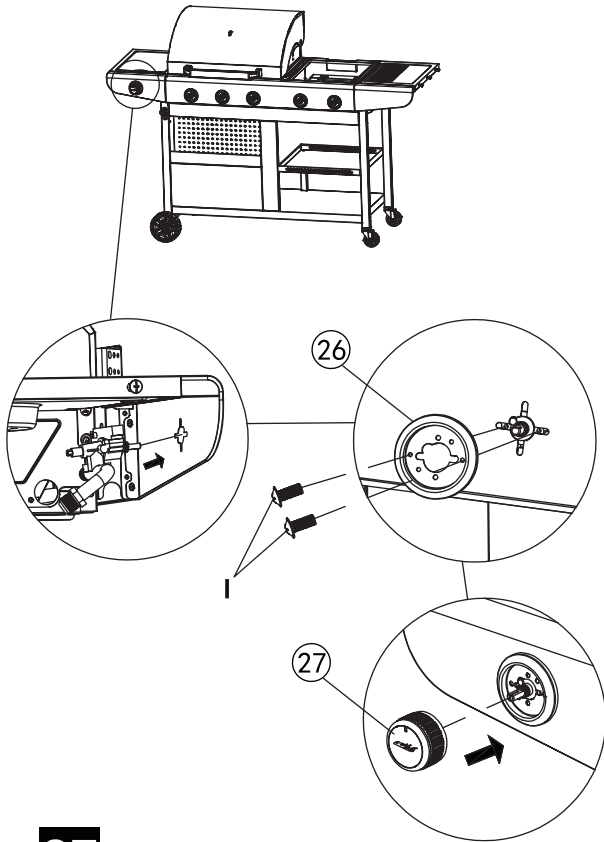

27

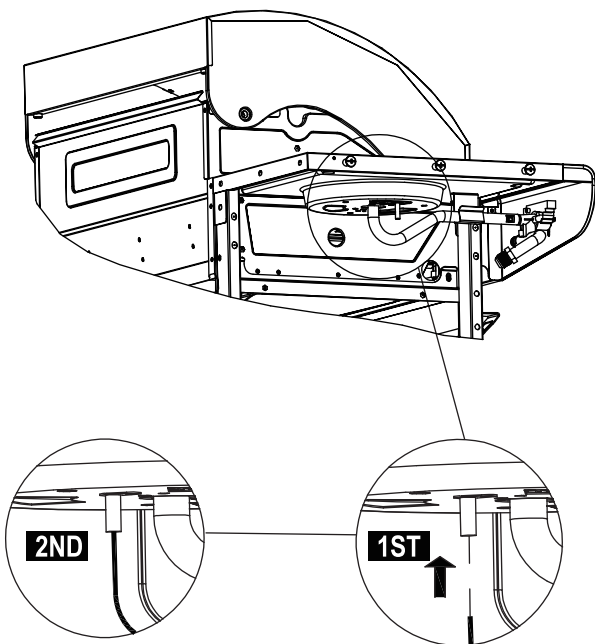

26 | 1 |  | x2

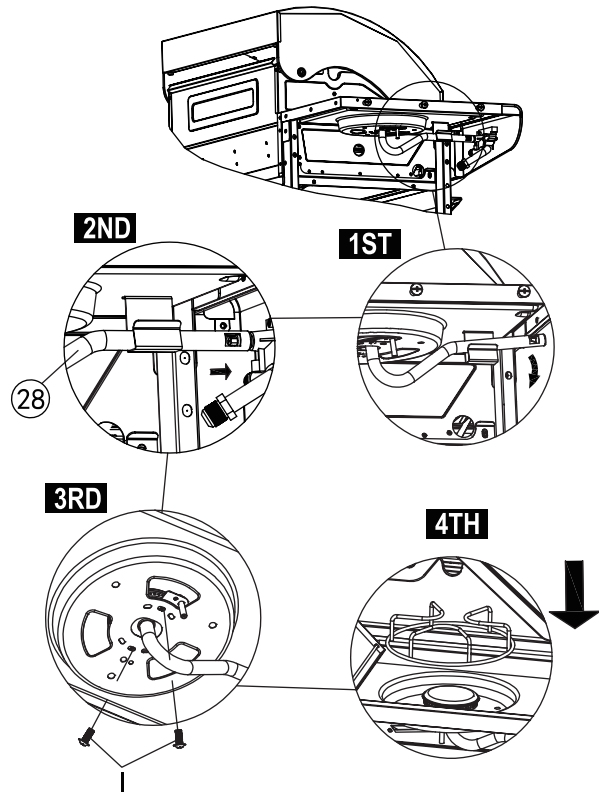

28 | C |  | x4

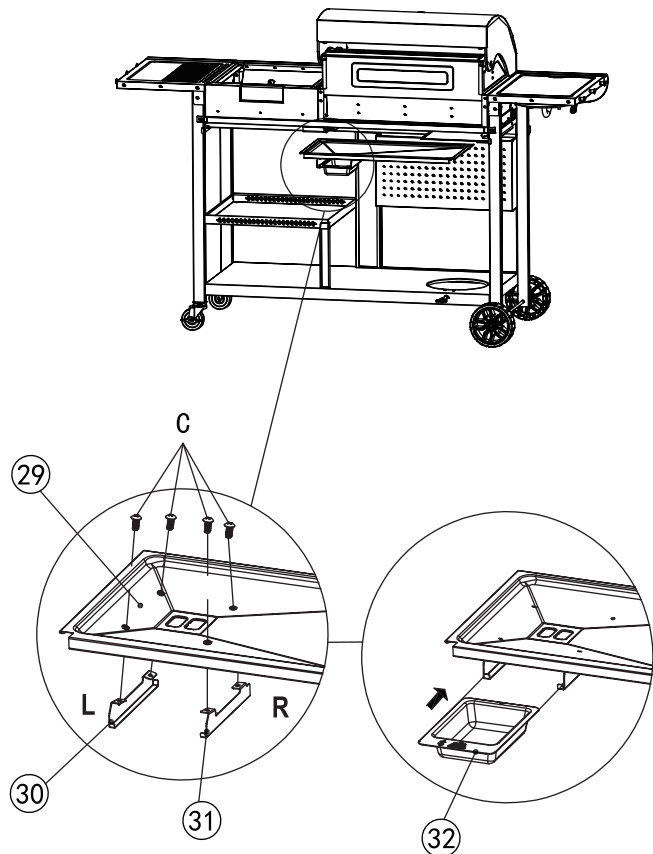

29

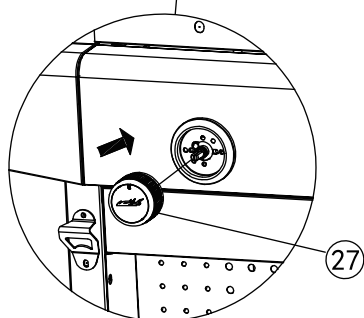
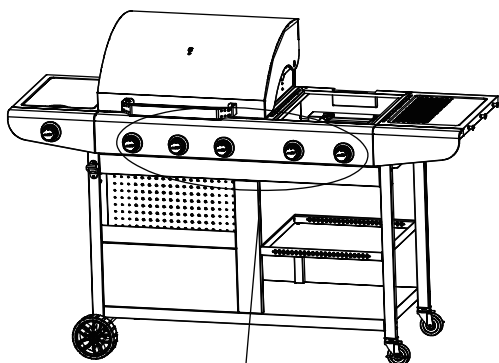

30

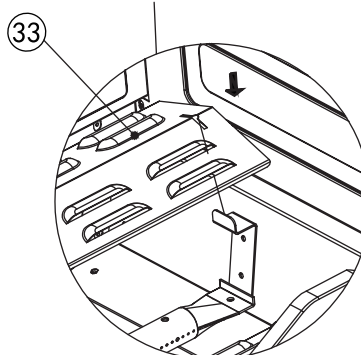
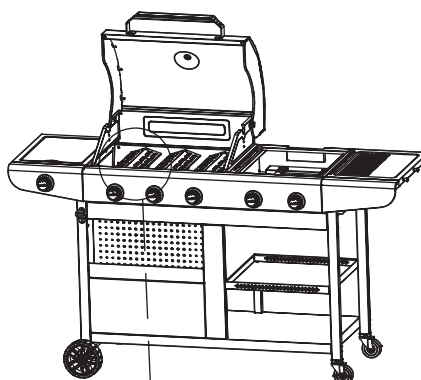

31

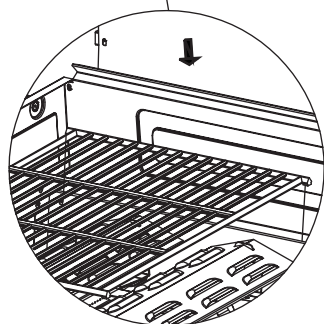
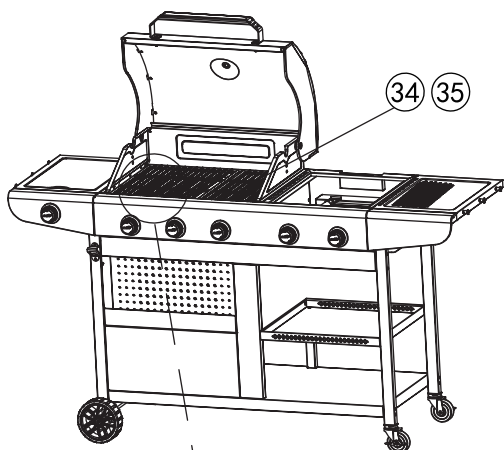

32

- Remove protective film before using.
- Retire la película protectora antes de usar.
- Retirez le film protecteur avant utilisation.

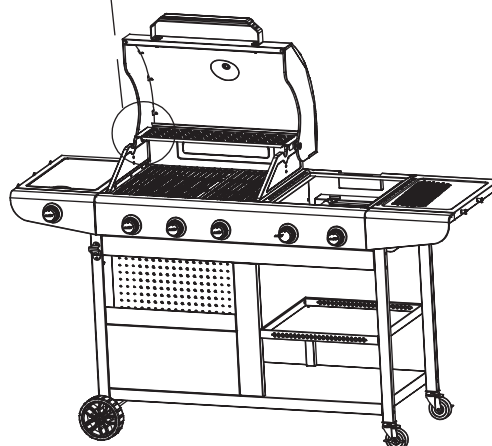
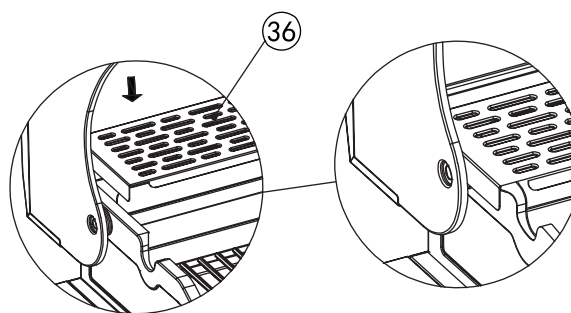

33 D  x1

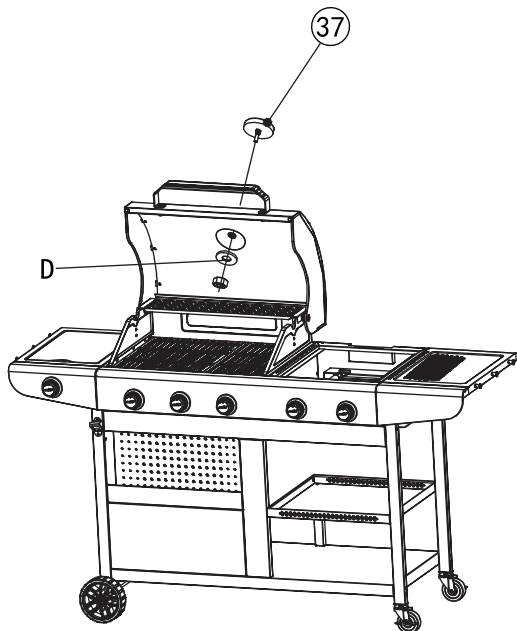

34 K  x2

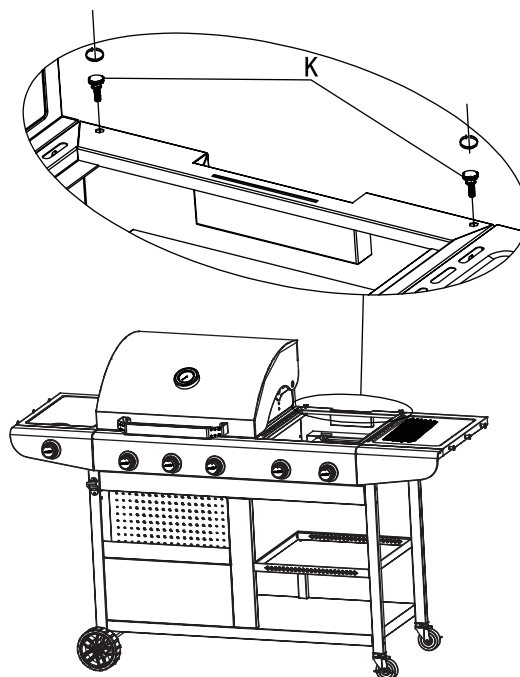

35

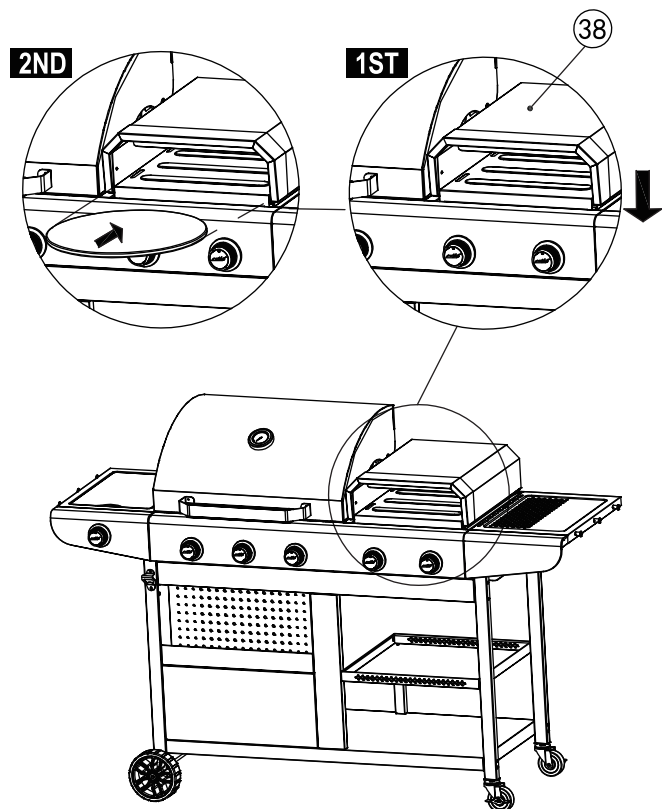

36

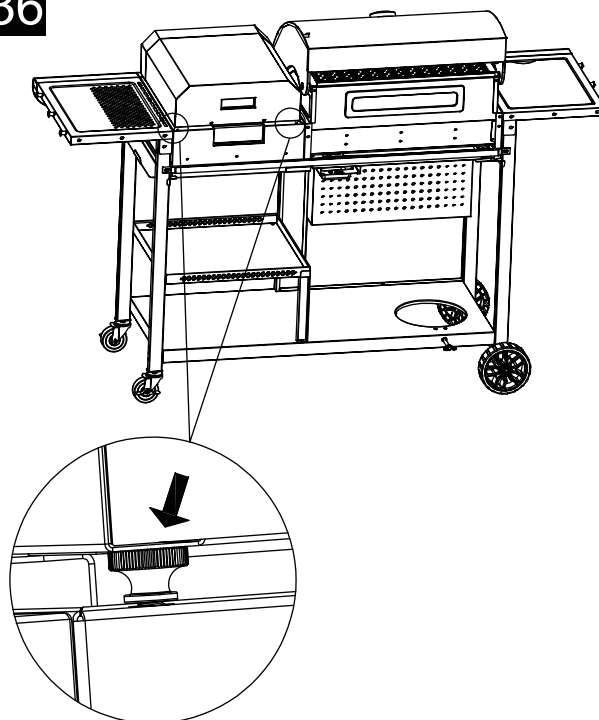

- Adjust the support screws to ensure the fatness of the pizza oven or griddle (*Griddle not included).
- Ajuste los tornillos de soporte para garantizar la gordura del horno de pizza o plancha (*Plancha no incluida).
- Ajuster les vis de support pour assurer la stabilité du four à pizza ou de la plaque de cuisson (*Plaque de cuisson non incluse).

**Thank You
For Choosing Us.**

**Any Problem!
We Can Help!**

**Customer
Service**

1-800-618-6798

Monday to Friday (8:30 am - 5:00 pm EST)

service@royalgourmetusa.com