

Save This Manual for Future Reference

Gasoline Engine

Operator's Manual



MODEL NUMBER

R210-S

SERIAL NUMBER

PURCHASE DATE

Both model number and serial number may be found on the main label. You should record both of them in a safe place for future use.

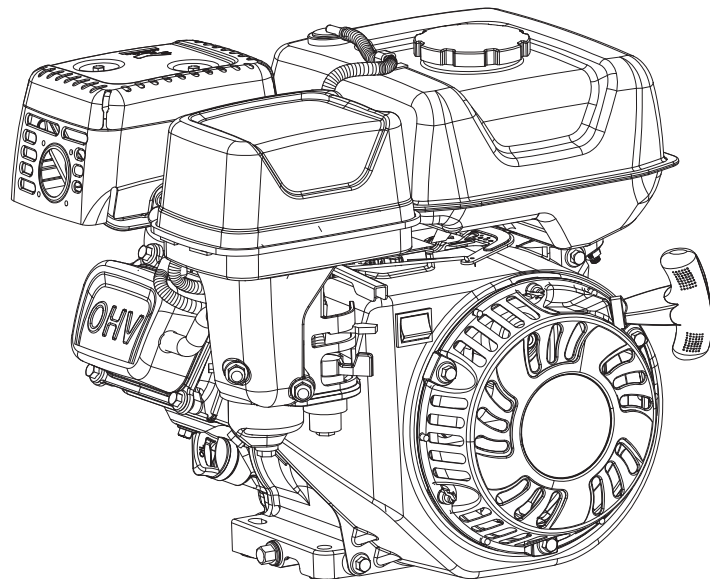

WARNING

READ AND UNDERSTAND THE ENTIRE MANUAL BEFORE OPERATING MACHINE. FAILURE TO COMPLY WITH THE SAFETY INSTRUCTIONS IN THE MANUAL MAY RESULT IN PERSONAL INJURY

GO FULL BOAR

Your new FULL BOAR® engine offers quality construction, and is easy and safe to operate. With proper use and care, it is designed to give you many years of dependable service.

Prepare to experience the durability to take on any job with the ease, portability, and convenience of your new engine!

Discover the FULL BOAR Advantage

At FULL BOAR, we understand that land ownership definitely has its privileges, but it also comes with a great deal of responsibility. When duty calls and you need to respond, will you have what it takes to tame the great outdoors?

When looking for outdoor power equipment (OPE) to get the job done right, at the right price, FULL BOAR delivers the perfect combination of performance and practicality. FULL BOAR has a solution that's right for you.

MAX Performance, MAX Value, MAX Support – that's FULL BOAR

- ✓ Backed by decades of proven manufacturing expertise
- ✓ Enhanced design features come standard
- ✓ Engineered for the best user experience
- ✓ Quality metal parts are used instead of plastic
- ✓ A robust warranty supports all products
- ✓ Budget-friendly prices make it practical



Up for the job? FULL BOAR is.

TABLE OF CONTENTS

Introduction	1
Specifications	3
Safety	3
Know Your Engine	4
Controls	5
Check before Operation	6

Operation	6
Maintenance	8
Storage / Transporting	13
Troubleshooting	15
Technical & Consumer Information	19
Wiring Diagram	21
California And Federal Exhaust And Evaporative Emissions Control Warranty Statement	22

DISCLAIMER

Keep this owner's manual handy, so you can refer to it at any time.

This owner's manual is considered a permanent part of the engine and should remain with the engine if resold.

The information and specifications included in this publication were in effect at the time of approval for printing.

READ THIS OWNER'S MANUAL CAREFULLY. Pay special attention to these symbols and any instructions that follow:

⚠ WARNING *Indicates serious injury or death will result if instructions are not followed.*

⚠ DANGER *Indicates a strong possibility that serious injury or death could result if instructions are not followed.*

⚠ CAUTION *Indicates a possibility that minor injury or an result if instructions are not followed.*

📌 NOTE *Indicates that equipment or property damage can result if instructions are not followed.*

If a problem should arise, or if you have any questions about your engine, consult your engine dealer.

⚠ WARNING *Carefully read through this entire operator's manual before using your new engine. Pay attention to all cautions and warnings.*

ENVIRONMENTAL

Recycle unwanted materials instead of disposing of them as waste. All tools, hoses, and packaging should be resorted, taken to the local recycling center and disposed of in an environmentally safe way.

ENGINE SERIAL NUMBER

Record the engine serial number on the front cover of this manual. You will need this serial number when ordering parts, and when making technical or warranty inquires.

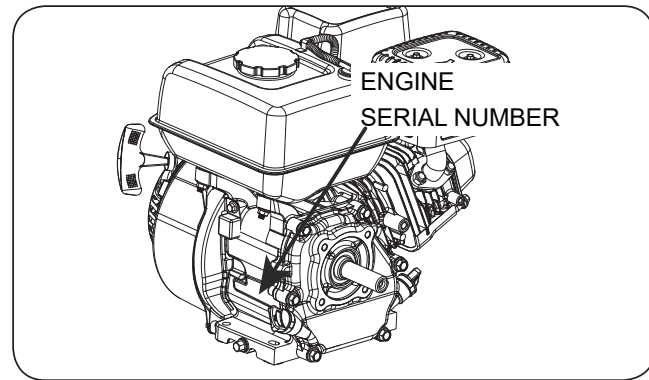
**DISCLAIMER**

FULLBOAR reserves the right to discontinue, change, and improve its products at any time without notice or obligation to the purchaser. The descriptions and specifications contained in this manual were in effect at printing. Equipment described within this manual may be optional. Some illustrations may not be applicable to your unit.

SUPPORT

Have questions about your FULLBOAR equipment? Call us at 844-FULLBOAR, email us at support@FULLBOAR.com, or contact us via your favorite social media site.

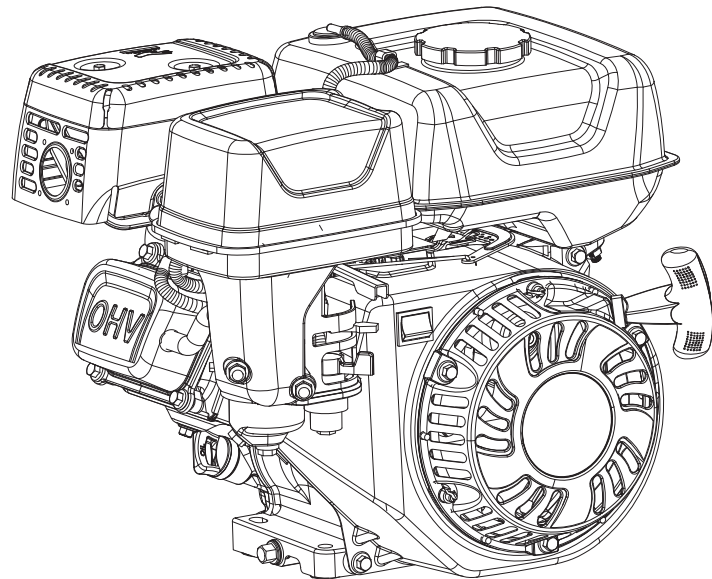

SPECIFICATIONS

Model	R210-S
Type	Single cylinder, 4-Stroke, Forced Air Cooling, OHV
Net Power (KW/3600rpm)	4.3
Max. torque (N•m/rpm)	12.4/2500
Fuel consumption (g/kW•h)	-
Idle speed	-
Speed Fluctuating Ratio	≤10%
Transmission Mode	-
Reduction Ratio	-
Bore×Stroke (mm)	74.5x48
Displacement (cc)	209
Compression Ratio	8:3:1

Lubricating mode	Splash
Starting Mode	Recoil start
Rotation	Counter-clockwise (from P.T.O. side)
Valve Clearance	input valve: 0.05 mm ~0.10mm, output valve: 0.05 mm ~0.10mm
Spark plug clearance	0.7 mm ~0.8mm
Igniting Mode	Transistorized Magneto Ignition
Air cleaner	Semi-dry, Oil bath, Foam filter
Dimension (Length) (mm)	360
Dimension (Width) (mm)	290
Dimension (High) (mm)	325
Net weight (lbs)	27.6

The power rating of the engine indicated in this document is the net power output tested on a production engine for the engine model and measured in accordance with SAE J1349 at 3,600 rpm (Net Power) and at 2,500 rpm (Max. Net Torque). Mass production engines may vary from this value.

Actual power output for the engine installed in the final machine will vary depending on numerous factors, including the operating speed of the engine in application, environmental conditions, maintenance, and other variables.

SAFETY

IMPORTANT SAFETY INFORMATION

Most accidents with engines can be prevented if you follow all instructions in this manual and on the engine. Some of the most common hazards are discussed below, along with the best way to protect yourself and others.

OWNER RESPONSIBILITIES

- The engines are designed to give safe and dependable service if operated according to instructions. Read and understand this owner's manual before operating the engine. Failure to do so could result in personal injury or equipment damage.
- Know how to stop the engine quickly, and understand the operation of all controls. Never permit anyone to operate the engine without proper instructions.
- Do not allow children to operate the engine. Keep children and pets far away from the area of operation.

REFUEL WITH CARE

Gasoline is extremely flammable, and gasoline vapor can explode. Refuel outdoors, in a well-ventilated area, with the engine stopped. Never smoke near gasoline, and keep other flames and sparks away. Always store gasoline in an approved container. If any fuel is spilled, make sure the area is dry before starting the engine.

HOT EXHAUST

- The muffler becomes very hot during operation and remains hot for a while after stopping the engine. Be careful not to touch the muffler while it is hot. Let the engine cool before storing it indoors.
- To prevent fire hazards and to provide adequate ventilation for stationary equipment applications, keep the engine at least 3 feet (1 meter) away from building walls and other equipment during operation. Do not place flammable objects close to the engine.

CARBON MONOXIDE HAZARD

Exhaust gas contains poisonous carbon monoxide. Avoid inhalation of exhaust gas. Never run the engine in a closed garage or confined area.

OTHER EQUIPMENT

Review the instructions provided with the equipment powered by this engine for any additional safety precautions that should be observed in conjunction with engine startup, shutdown, operation, or protective apparel that may be needed to operate the equipment.

KNOW YOUR ENGINE

FEATURES AND CONTROLS

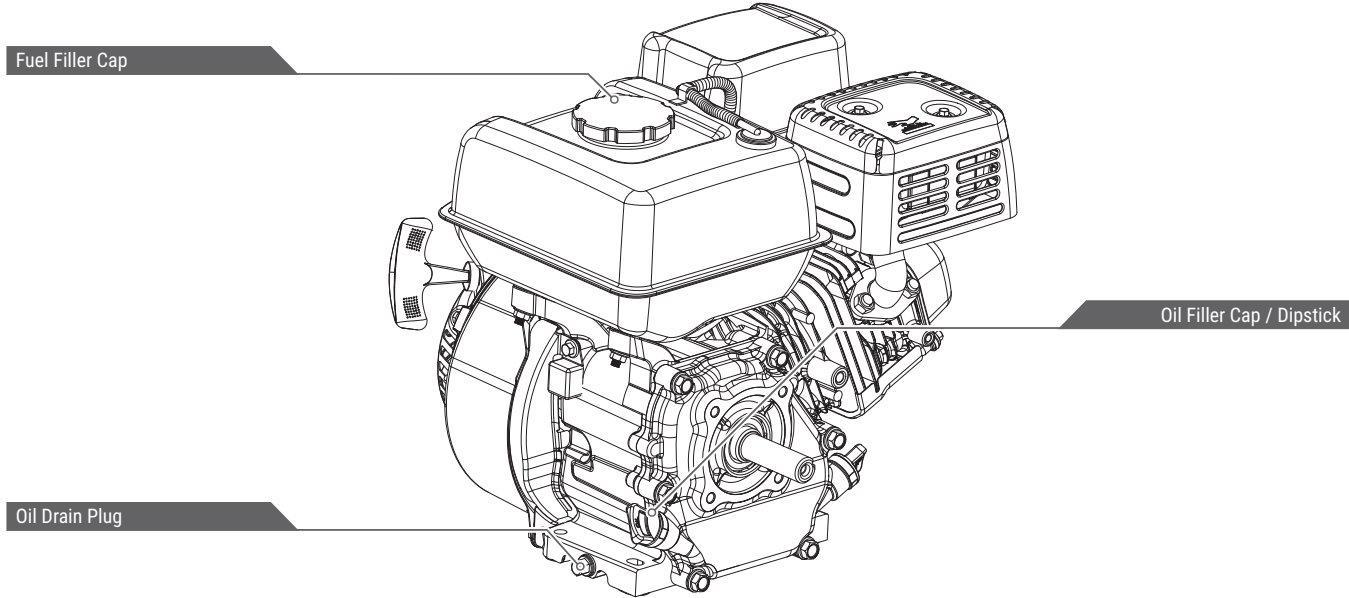
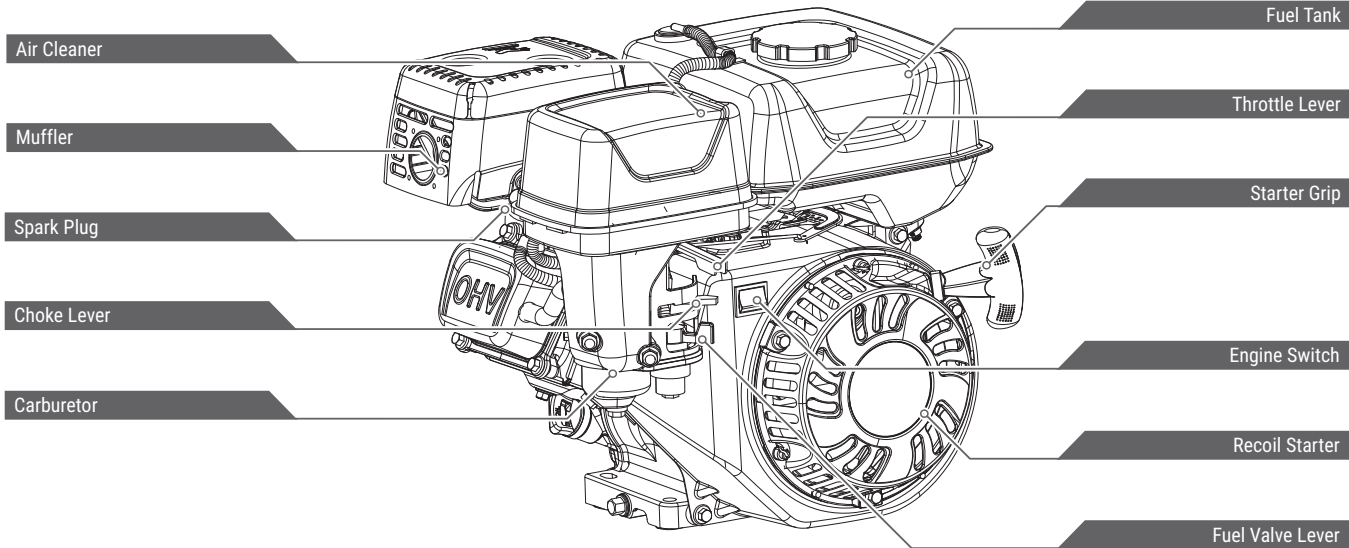

CONTROLS

FUEL VALVE LEVER

The fuel valve opens and closes the passage between the fuel tank and the carburetor.

The fuel valve lever must be in the ON position for the engine to run.

When the engine is not in use, leave the fuel valve lever in the OFF position to prevent carburetor flooding and to reduce the possibility of fuel leakage.

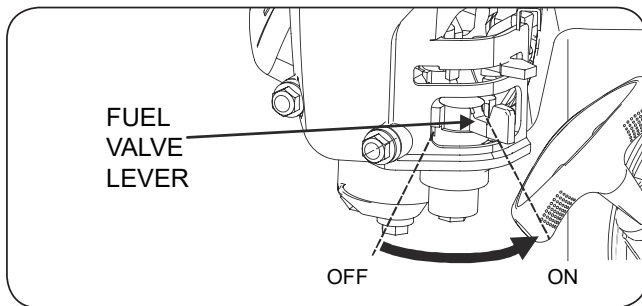

CHOKE LEVER

The choke lever opens and closes the choke valve in the carburetor.

The CHOKE position enriches the fuel mixture for starting a cold engine.

The RUN position provides the correct fuel mixture for operation after starting, and for restarting a warm engine.

Some engine applications use a remotely-mounted choke control rather than the engine-mounted choke lever shown here.

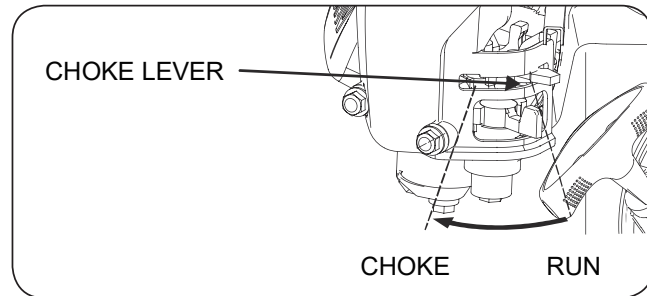

THROTTLE LEVER

The throttle lever controls engine THROTTLE LEVER speed.

Moving the throttle lever in the directions shown makes the engine run faster or slower.

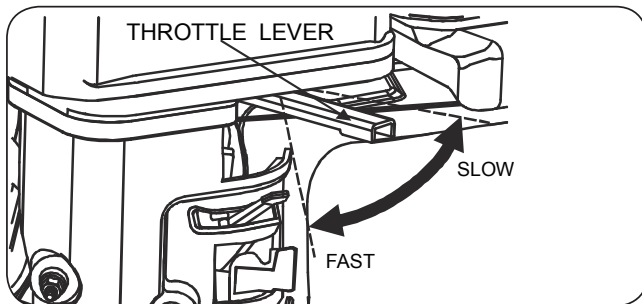

RECOIL STARTER GRIP

Pull the starter grip to crank the engine.

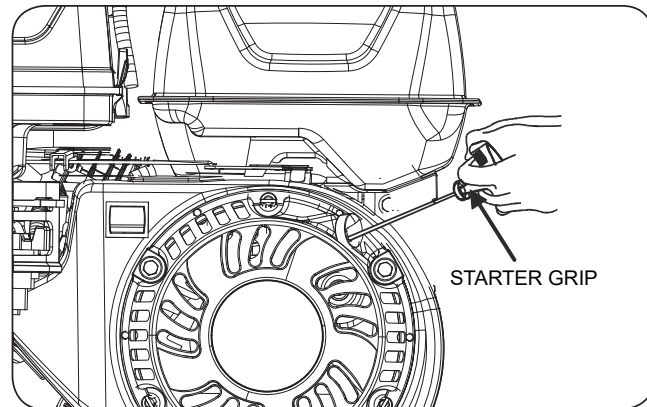

ENGINE SWITCH

The engine switch enables and disables the ignition system.

The engine switch must be in the "—" position for the engine to run.

Turning the engine switch to the "0" position stops the engine.

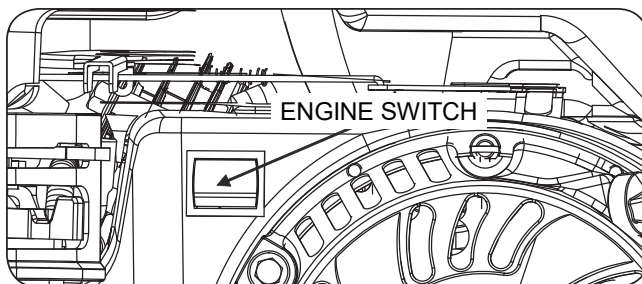

CHECK BEFORE OPERATION

IS YOUR ENGINE READY TO GO?

For your safety, and to maximize the service life of your equipment, it is very important to take a few moments before you operate the engine to check its condition. Be sure to take care of any problem you find, or have your servicing dealer correct it, before you operate the engine.

⚠ WARNING *Improperly maintaining this engine, or failing to correct a problem before operation, could cause a malfunction in which you could be seriously injured. Always perform a preoperation inspection, and correct any problem.*

Before beginning your preoperation checks, be sure the engine is level and the engine switch is in the OFF position.

CHECK THE GENERAL CONDITION OF THE ENGINE

- Look around and underneath the engine for signs of oil or gasoline leaks.
- Remove any excessive dirt or debris, especially around the muffler and recoil starter.

- Look for signs of damage.
- Check that all shields and covers are in place, and all nuts, bolts, and screws are tightened.

CHECK THE ENGINE

Check the engine oil level. Running the engine with a low oil level can cause engine damage.

The Oil Alert system (applicable engine types) will automatically stop the engine before the oil level falls below safe limits. However, to avoid the inconvenience of an unexpected shutdown, always check the engine oil level before startup.

Check the air filter. A dirty air filter will restrict air flow to the carburetor, reducing engine performance.

Check the fuel level. Starting with a full tank will help to eliminate or reduce operating interruptions for refueling.

CHECK THE EQUIPMENT POWERED BY THIS ENGINE

Review the instructions provided with the equipment powered by this engine for any precautions and procedures that should be followed before engine startup.

OPERATION

SAFE OPERATING PRECAUTIONS

Before operating the engine for the first time, please review the IMPORTANT SAFETY INFORMATION and the chapter titled BEFORE OPERATION.

⚠ WARNING *Carbon monoxide gas is toxic. Breathing it can cause unconsciousness and even kill you. Avoid any areas or actions that expose you to carbon monoxide.*

Review the instructions provided with the equipment powered by this engine for any safety precautions that should be observed in conjunction with engine startup, shutdown, or operation.

STARTING THE ENGINE

1. Move the fuel valve lever to the ON position.

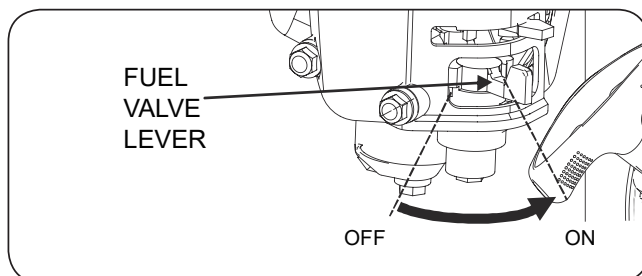

2. To start a cold engine, move the choke lever to the CHOKE position.

To restart a warm engine, leave the choke lever in the RUN position.

Some engine applications use a remotely-mounted choke control rather than the engine-mounted choke lever shown here.

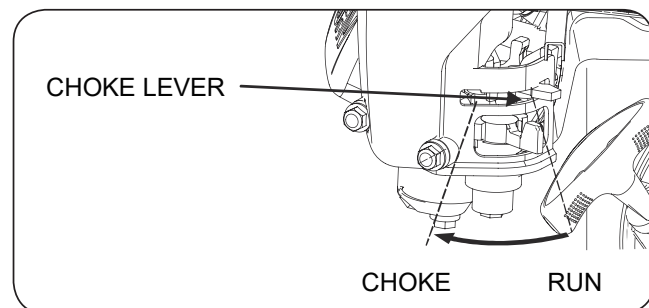

3. Move the throttle lever away from the SLOW position, about 1/3 of the way toward the FAST position.

Some engine applications use a remotely-mounted throttle control rather than the engine-mounted throttle lever shown here.

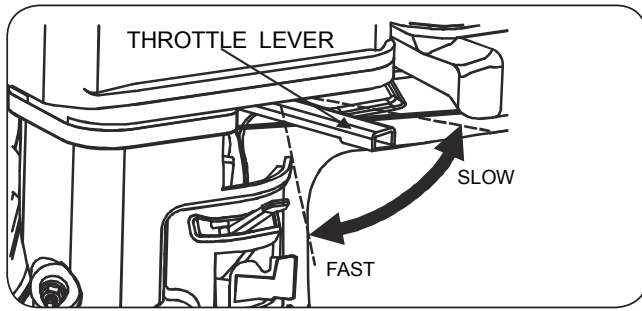

- Turn the engine switch to the "—" position.

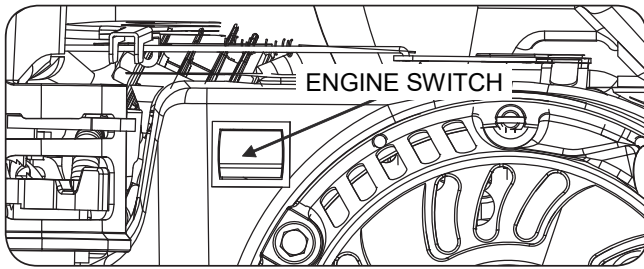

- Operate the starter.

RECOIL STARTER (all engine types):

Pull the starter grip lightly until you feel resistance, then pull briskly.

Return the starter grip gently.

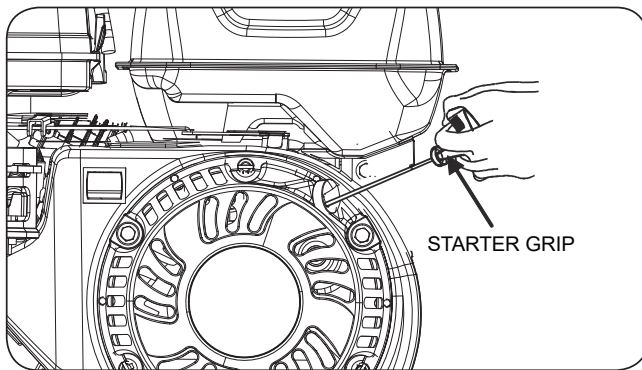

- If the choke lever has been moved to the CHOKE position to start the engine, gradually move it to the RUN position as the engine warms up.

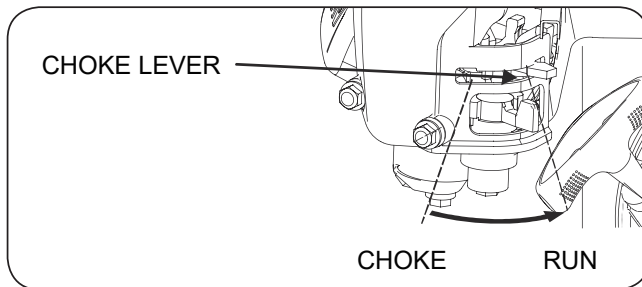

STOPPING THE ENGINE

To stop the engine in an emergency, simply turn the engine switch to the OFF position. Under normal conditions, use the following procedure.

- Move the throttle lever to the SLOW position.

Some engine applications use a remotely-mounted throttle control rather than the engine-mounted throttle lever shown here.

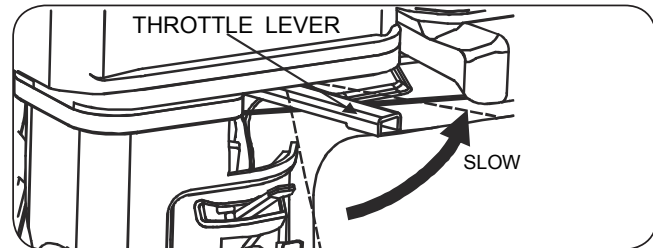

- Turn the engine switch to the "0" position.

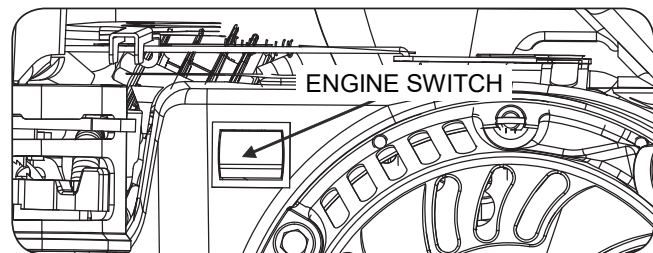

- Turn the fuel valve lever to the OFF position.

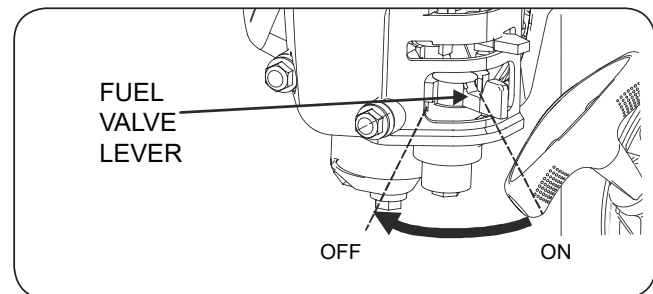

SETTING ENGINE SPEED

Position the throttle lever for the desired engine speed.

Some engine applications use a remotely-mounted throttle control rather than the engine-mounted throttle lever shown here.

For engine speed recommendations, refer to the instructions provided with the equipment powered by this engine.

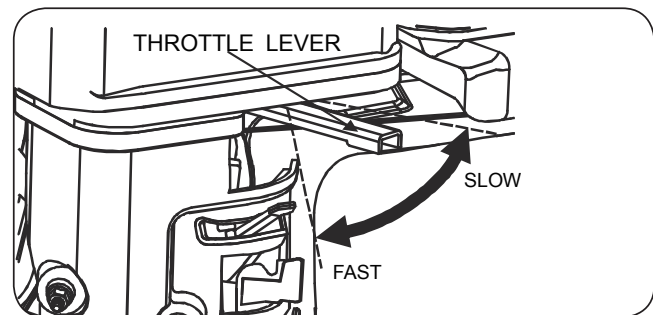

MAINTENANCE

THE IMPORTANCE OF MAINTENANCE

Good maintenance is essential for safe, economical, and trouble-free operation. It will also help reduce air pollution.

! WARNING *Improperly maintaining this engine, or failure to correct a problem before operation, can cause a malfunction in which you can be seriously hurt or killed. Always follow the inspection and maintenance recommendations and schedules in this owner's manual.*

To help you properly care for your engine, the following pages include a maintenance schedule, routine inspection procedures, and simple maintenance procedures using basic hand tools. Other service tasks that are more difficult, or require special tools, are best handled by professionals and are normally performed by a technician or other qualified mechanic.

The maintenance schedule applies to normal operating conditions. If you operate your engine under unusual conditions, such as sustained high-load or high-temperature operation, or use in unusually wet or dusty conditions, consult your servicing dealer for recommendations applicable to your individual needs and use.

MAINTENANCE SAFETY PRECAUTIONS

Some of the most important safety precautions are as follows: However, we cannot warn you of every conceivable hazard that can arise in performing maintenance. Only you can decide whether or not you should perform a given task.

! WARNING *Failure to properly follow maintenance instructions and precautions can cause you to be seriously hurt or killed. Always follow the procedures and precautions in the owner's manual.*

1. Make sure the engine is off before you begin any maintenance or repairs. This will eliminate several potential hazards:
 - **Carbon monoxide poisoning from engine exhaust.**
Be sure there is adequate ventilation whenever you operate the engine.
 - **Burns from hot parts.**
Let the engine and exhaust system cool before touching.
 - **Injury from moving parts.**
Do not run the engine unless instructed to do so.
2. Read the instructions before you begin, and make sure you have the tools and skills required.
3. To reduce the possibility of fire or explosion, be careful when working around gasoline. Use only a nonflammable solvent, not gasoline, to clean parts. Keep cigarettes, sparks and flames away from all fuel-related parts.

Remember that your servicing dealer knows your engine best and is fully equipped to maintain and repair it.

To ensure the best quality and reliability, use only new, genuine parts or their equivalents for repair and replacement.

MAINTENANCE SCHEDULE

The engine must be properly maintained to ensure its operation be safe, economy and trouble-free, as well as eco-friendly.

In order to keep your gasoline engine in good working condition, it must be periodically serviced. The following maintenance schedule and routine inspection procedures must be carefully followed

REGULAR SERVICE PERIOD Performed at every indicated month or operating hour interval, whichever comes first.			Each use	First month or 20 Hrs.	Every 3 months or 50 Hrs.	Every year or 100 Hrs.
ITEM						
●	Engine oil	Check- Refill	○			
		Replace		○	○	
●	Reduction gear oil	Check- Refill	○			
		Replace		○	○	
●	Air cleaner	Check	○			
		Clean		○ (1)		
		Replace			○	
●	Sediment cup	Clean				○
●	Spark plug	Check - Adjust				○ ☆
	Spark arrester (optional parts)	Clean			○	
●	Idle speed	Check-Adjust				○ (2)
●	Valve clearance	Check-Adjust				○ (2)
●	Fuel tank and Fuel filter	Clean				○ (2)
●	Fuel line	Check	Every 2 years(change if necessary)			
●	Cylinder head, piston	Clean up carbon	<225cc, Every 125hrs ≥225cc, Every 250hrs (2)			

● Emission-related items.

☆ These items should be replaced if replacement needed.

(1) Service more frequently when used in dusty areas.

(2) These items should be serviced by your servicing dealer unless you have the proper tools and are mechanically proficient. Refer to manual for service procedures.

NOTE

- If the gasoline engine frequently work under high temperature or heavy load, change the oil every 25 hours.
- If the engine frequently work under dusty or other severe circumstances, clean the air filter element every 10 hours; If necessary, change the air filter element every 25 hours.
- The maintenance period and the exact time (hour), the one which comes first should govern.

REFUELING

Fuel tank capacities : 0.68 gallons (2.6L)

With the engine stopped, remove the fuel tank cap and check the fuel level. Refill the tank if the fuel level is low.

! WARNING Gasoline is highly flammable and explosive. You can be burned or seriously injured when handling fuel.

- Stop the engine and keep heat, sparks, and flame away.
- Handle fuel only outdoors.
- Wipe up spills immediately.

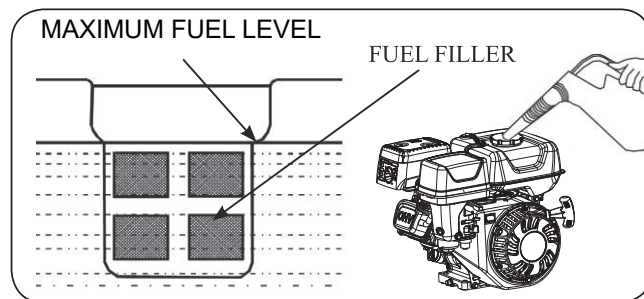

Refuel in a well-ventilated area before starting the engine. If the engine has been running, allow it to cool. Refuel carefully to avoid spilling fuel. Do not fill above the fuel strainer shoulder. After refueling, tighten the fuel tank cap securely.

Never refuel the engine inside a building where gasoline fumes may reach flames or sparks. Keep gasoline away from appliance pilot lights, barbecues, electric appliances, power tools, etc.

Spilled fuel is not only a fire hazard, it causes environmental damage. Wipe up spills immediately.

! WARNING Fuel can damage paint and plastic. Be careful not to spill fuel when filling your fuel tank. Damage caused by spilled fuel is not covered under warranty.

FUEL RECOMMENDATIONS

Use unleaded gasoline with a pump octane rating of 86 or higher.

These engines are certified to operate on unleaded gasoline. Unleaded gasoline produces fewer engine and spark plug deposits and extends exhaust system life.

Never use stale or contaminated gasoline or an oil/gasoline mixture. Avoid getting dirt or water in the fuel tank.

Occasionally you may hear a light "spark knock" or "pinging" (metallic rapping noise) while operating under heavy loads. This is no cause for concern.

If spark knock or pinging occurs at a steady engine speed, under normal load, change brands of gasoline. If spark knock or pinging persists, see an authorized servicing dealer.

! WARNING Running the engine with persistent spark knock or pinging can cause engine damage.

Running the engine with persistent spark knock or pinging is considered misuse, and the Distributor's Limited Warranty does not cover parts damaged by misuse.

ENGINE OIL LEVEL CHECK

Check the engine oil level with the engine stopped and in a level position.

1. Remove the filler cap/dipstick and wipe it clean.

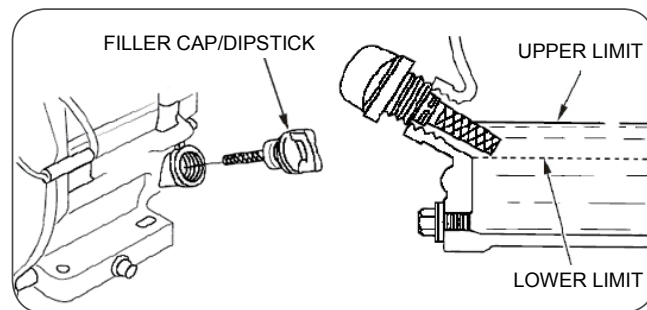

2. Insert and remove the dipstick without screwing it into the filler neck. Check the oil level shown on the dipstick.
3. If the oil level is low, fill to the edge of the oil filler hole with the recommended oil.
4. Screw in the filler cap/dipstick securely.

! WARNING Running the engine with a low oil level can cause engine damage.

The Oil Alert system (applicable engine types) will automatically stop the engine before the oil level falls below safe limit. However, to avoid the inconvenience of an unexpected shutdown, always check the engine oil level before startup.

ENGINE OIL CHANGE

Drain the used oil while the engine is warm. Warm oil drains quickly and completely.

1. Place a suitable container below the engine to catch the used oil, and then remove the filler cap/dipstick and the drain plug.
2. Allow the used oil to drain completely, and then reinstall the drain plug, and tighten it securely.

Please dispose of used motor oil in an environmental friendly way.

We suggest you take used oil in a sealed container to your local recycling center or service station for reclamation. Do not throw it in the trash; pour it on the ground; or down a drain.

3. With the engine in a level position, fill to the outer edge of the oil filler hole with the recommended oil.

Engine oil capacities: 16.9 oz.(0.5L)

Running the engine with a low oil level can cause engine damage.

The Oil Alert system (applicable engine types) will automatically stop the engine before the oil level falls below the safe limit.

However, to avoid the inconvenience of an unexpected shutdown, fill to the upper limit, and check the oil level regularly.

4. Screw in the filler cap/dipstick securely.

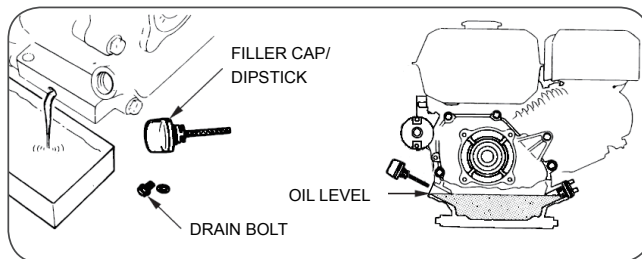

ENGINE OIL RECOMMENDATIONS

Oil is a major factor affecting performance and service life. Use 4-stroke automotive engine oil.

SAE 10W-30 is recommended for general use. Other viscosities shown in the chart may be used when the average temperature in your area is within the recommended range.

The SAE oil viscosity and service classification are in the API label on the oil container. We recommend that you use API SERVICE Category SE or SF oil.

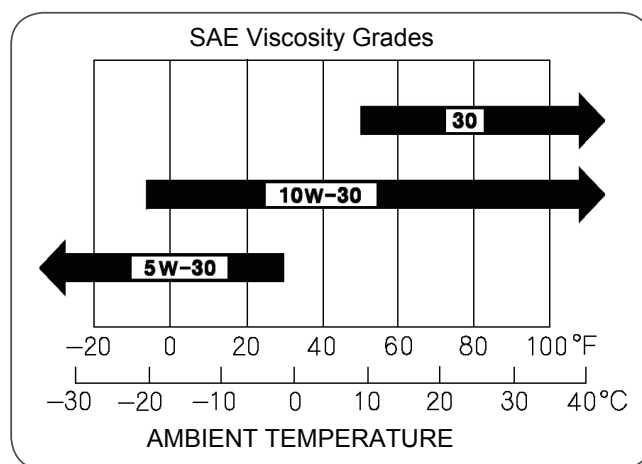

AIR FILTER INSPECTION

Remove the air cleaner cover and inspect the filter. Clean or replace dirty filter elements. Always replace damaged filter elements. If equipped with an oil-bath air cleaner, also check the oil level.

AIR CLEANER SERVICE

A dirty air filter will restrict air flow to the carburetor, reducing engine performance.

If you operate the engine in very dusty areas, clean the air filter more often than specified in the MAINTENANCE SCHEDULE.

WARNING *Operating the engine without an air filter, or with a damaged air filter, will allow dirt to enter the engine, causing rapid engine wear. This type of damage is not covered by the Distributor's Limited Warranty.*

1. Remove the air cleaner cover.
2. Remove the foam filter .
3. Inspect air filter elements, and replace them if they are damaged. Always replace the paper air filter element at the scheduled interval.
4. Clean the air filter elements if they are to be reused.
5. Foam air filter element: Clean in warm soapy water, rinse, and allow drying thoroughly. Or clean in nonflammable solvent and allow drying. Dip the filter element in clean engine oil, and then squeeze out all excess oil. The engine will smoke when started if too much oil is left in the foam.
6. Wipe dirt from the inside of the air cleaner base and cover, using a moist rag. Be careful to prevent dirt from entering the air duct that leads to the carburetor.
7. Reinstall the cleaned air filter. Be sure the gasket is in place beneath the air filter. Tighten the air filter wing nut securely.

SEDIMENT CUP CLEANING

1. Move the fuel valve to the OFF position, and then remove the fuel sediment cup and O-ring.

WARNING *Gasoline is highly flammable and explosive.*

You can be burned or seriously injured when handling fuel.

- Keep heat, sparks and flame away.
- Handle fuel only outdoors.
- Wipe up spills immediately.

2. Wash the sediment cup and O-ring in nonflammable solvent, and dry them thoroughly.
3. Place the O-ring in the fuel valve, and install the sediment cup. Tighten the sediment cup securely.
4. Move the fuel valve to the ON position, and check for leaks. Replace the O-ring if there is any leakage.

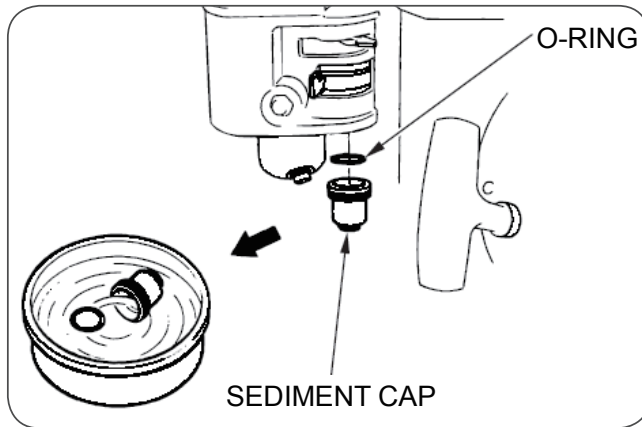

SPARK PLUG SERVICE

Recommended spark plugs: F7RTC or other equivalents.

⚠ WARNING *An incorrect spark plug can cause engine damage.*

1. Disconnect the spark plug cap, and remove any dirt from around the spark plug area.
2. Remove the spark plug with a spark plug wrench.

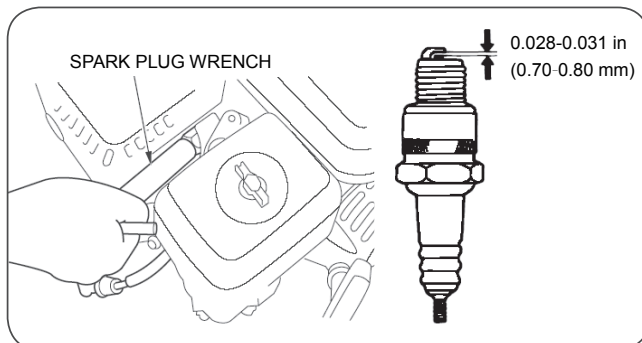

3. Inspect the spark plug. Replace it if the electrodes are worn, or if the insulator is cracked or chipped.
4. Measure the spark plug electrode gap with a suitable gauge.
The gap should be 0.028 in - 0.031 in (0.70 mm - 0.80 mm). Correct the gap, if necessary, by carefully bending the side electrode.
5. Install the spark plug carefully, by hand, to avoid cross-threading.
6. After the spark plug seats, tighten with a spark plug wrench to compress the water.

⚠ WARNING *A loose spark plug can overheat and damage the engine. Over tightening the spark plug can damage the threads in the cylinder head.*

7. Attach the spark plug cap.

IDLE SPEED ADJUSTMENT

1. Start the engine outdoors, and allow it to warm up to operating temperature.
2. Move the throttle lever to its slowest position.
3. Turn the throttle stop screw to obtain the standard idle speed.

Standard idle speed: 1800±150 rpm

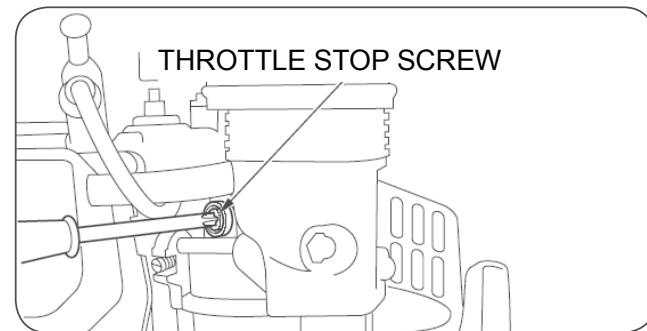

SPARK ARRESTER SERVICE (optional equipment)

Your engine is not factory-equipped with a spark arrester. In some areas, it is illegal to operate an engine without a spark arrester. Check local laws and regulations. A spark arrester is available from authorized servicing dealers.

The spark arrester must be serviced every 100 hours to keep it functioning as designed.

If the engine has been running, the muffler will be very hot. Allow the muffler to cool before servicing the spark arrester.

1. Remove the three 4 mm screws from the exhaust deflector, and remove the deflector.
2. Remove the four 5 mm screws from the muffler protector and remove the muffler protector.
3. Remove the 4 mm screw from the spark arrester, and remove the spark arrester from the muffler.

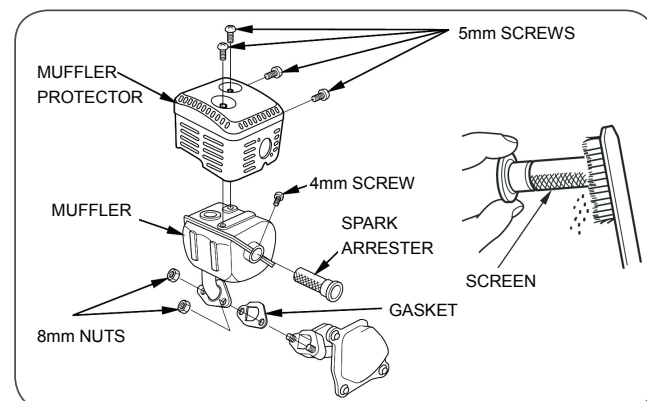

4. Use a brush to remove carbon deposits from the spark arrester screen. Be careful to avoid damaging the screen.

The spark arrester must be free of breaks and holes. Replace the spark arrester if it is damaged.

5. Install the spark arrester, muffler protector, and exhaust deflector in the reverse order of disassembly.

⚠ WARNING *Never use an engine without an appropriate spark arrester in the forest areas! Doing so may cause a fire!*

STORAGE / TRANSPORTING

STORAGE PREPARATION

Proper storage preparation is essential for keeping your engine trouble free and looking good. The following steps will help to keep rust and corrosion from impairing your engine's function and appearance, and will make the engine easier to start after storage.

CLEANING

If the engine has been running, allow it to cool for at least half an hour before cleaning. Clean all exterior surfaces, touch up any damaged paint, and coat other areas that may rust with a light film of oil.

⚠ WARNING *Using a garden hose or pressure washing equipment can force water into the air cleaner or muffler opening. Water in the air cleaner will soak the air filter, and water that passes through the air filter or muffler can enter the cylinder, causing damage. Water contacting a hot engine can cause damage. If the engine has been running, allow it to cool for at least half an hour before washing.*

FUEL

Gasoline will oxidize and deteriorate in storage. Old gasoline will cause hard starting, and it leaves gum deposits that clog the fuel system. If the gasoline in your engine deteriorates during storage, you may need to have the carburetor and other fuel system components serviced or replaced.

The Distributor's Limited Warranty does not cover fuel system damage or engine performance problems resulting from neglected storage preparation.

You can extend fuel storage life by adding a fuel stabilizer that is formulated for that purpose, or you can avoid fuel deterioration problems by draining the fuel tank and carburetor.

ADDING A FUEL STABILIZER TO EXTEND FUEL STORAGE LIFE

When adding a fuel stabilizer, fill the fuel tank with fresh gasoline. If only partially filled, air in the tank will promote fuel deterioration during storage. If you keep a container of gasoline for refueling, be sure that it contains only fresh gasoline.

1. Add fuel stabilizer following the manufacturer's instructions.
2. After adding a fuel stabilizer, run the engine outdoors for 10 minutes to be sure that treated gasoline has replaced the untreated gasoline in the carburetor.
3. Stop the engine, and move the fuel valve to the OFF position.

DRAINING THE FUEL TANK AND CARBURETOR

1. Place an approved gasoline container below the carburetor, and use a funnel to avoid spilling fuel.
2. Remove the carburetor drain bolt and sediment cup, and then move the fuel valve lever to the ON position.

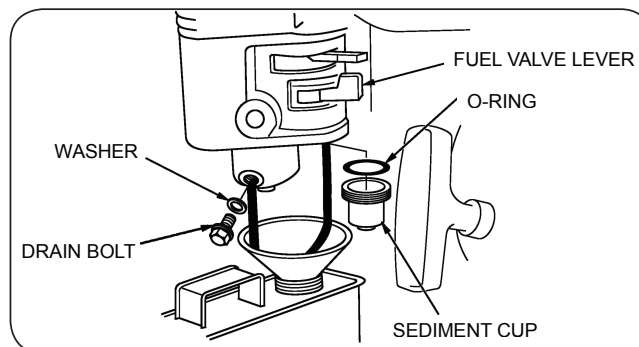

3. After all the fuel has drain into the container, reinstall the drain bolt and sediment cup. Tighten them securely.

⚠ WARNING *The length of time that gasoline can be left in your fuel tank and carburetor without causing functional problems will vary with such factors as gasoline blend, your storage temperatures, and whether the fuel tank is partially or completely filled. The air in a partially filled fuel tank promotes fuel deterioration. Very warm storage temperatures accelerate fuel deterioration. Gasoline will oxidize and deteriorate in storage. Deteriorated gasoline will cause hard starting, and it leaves gum deposits that clog the fuel system. As a result, If the engine is not used for more than one month, the fuel oil shall be drained thoroughly to prevent from deterioration of the fuel in fuel system and carburetor. The failures of fuel system or engine performance arising from improper storage are beyond the scope of the warranty.*

STORAGE PRECAUTIONS

1. Change the engine oil.
2. Remove the spark plugs.
3. Pour a tablespoon (5-10 cc) of clean engine oil into the cylinder.
4. Pull the starter rope several times to distribute the oil in the cylinder.
5. Reinstall the spark plugs.
6. Pull the starter rope slowly until resistance is felt. This will close the valves so moisture cannot enter the engine cylinder. Return the starter rope gently.

If your engine will be stored with gasoline in the fuel tank and carburetor, it is important to reduce the hazard of gasoline vapor ignition. Select a well-ventilated storage area away from any appliance that operates with a flame, such as a furnace, water heater, or clothes dryer. Also avoid any area with a spark-producing electric motor, or where power tools are operated.

If possible, avoid storage areas with high humidity, because that promotes rust and corrosion.

Unless all fuel has been drained from the fuel tank, leave the fuel valve lever in the OFF position to reduce the possibility of fuel leakage.

Position the equipment so the engine is level. Tilting can cause fuel or oil leakage.

With the engine and exhaust system cool, cover the engine to keep out dust. A hot engine and exhaust system can ignite or melt some materials. Do not use sheet plastic as a dust cover. A nonporous cover will trap moisture around the engine, promoting rust and corrosion.

If equipped with a battery for an electric starter, recharge the battery once a month while the engine is in storage. This will help to extend the service life of the battery.

REMOVAL FROM STORAGE

Check your engine as described in the chapter CHECK BEFORE OPERATION.

If the fuel was drained during storage preparation, fill the tank with fresh gasoline. If you keep a container of gasoline for refueling, be sure that it contains only fresh gasoline. Gasoline oxidizes and deteriorates over time, causing hard starting.

If the cylinders were coated with oil during storage preparation, the engine may smoke briefly at startup. This is normal.

TRANSPORTING

If the engine has been running, allow it to cool for at least 15 minutes before loading the engine-powered equipment on the transport vehicle. A hot engine and exhaust system can burn you and can ignite some materials.

Keep the engine level when transporting to reduce the possibility of fuel leakage. Move the fuel valve lever to the OFF position.

TROUBLESHOOTING

Start Engine Difficultly (By using recoil starter)

TROUBLE		CAUSE	REMEDY
Normal cylinder compression	Normal spark plug spark	Fuel supply is not smooth or no fuel supply 1. There is no enough fuel in fuel tank and fuel cock is closed. 2. Air vent in the fuel filler cap is clogged 3. Fuel cock is clogged 4. Improper or clogged main oil flow hole 5. Needle valve is not closed properly or start hole is clogged 6. Float is damaged or sticking	1. Fill fuel, open fuel cock. 2. Dredge air vent. 3. Clean first and then dredge 4. Readjust or clean, blow to get through 5. Dismantle needle valve and repair, clean, blow to get through 6. Repair float
		Fuel supply is normal 1. Fuel is too filthy or deterioratd 2. There is water in fuel 3. Too much fuel in engine 4. Wrong fuel brand	1. Replace 2. Replace 3. Drain extra fuel, diy up spark plug electrodes 4. Select proper fuel brand corresponding with the requirements.
	Normal fuel supply system	Normal high-tension line spark Spark plug is in bad conditions 1. Too much carbon deposit and dirt around electrodes 2. Electrodes are birni damaged seriously or insulators damaged. 3. Improper electrodes gap.	1. Clear away. 2. Replace spark plug. 3. Adjust to proper value.
	High-tension line no spark	Normal spark plug 1. High tension line is damaged. 2. Ignition coil is damaged 3. Magneto loses magnetism 4. Wrong gap between ignition coil and flywheel	1. Replace 2. Replace 3. Replace 4. Adjust gap between ignition and flywheel
Abnormal cylinder compression	Normal fuel supply system	Normal spark plug 1. Piston ring is worn to or even over its wear limit 2. Piston ring is broken 3. Piston ring is sticking 4. Spark plug is not installed tighten or without a gasket 5. Air leakage between cylinder block and cylinder head 6. Air leakage in the valves	1. Replace 2. Replace 3. Clear up carbon fouling 4. Tighten with a gasket in 5. Check cylinder gasket, and the flatness of the surface by which cylinder block contacting with cylinder head Tighten cylinder head bolts in stipulated order to stipulated torque. 6. Check valve. Clearance and tightness, repair if necessary.

Gasoline Engine Power Output Insufficiency

TROUBLE	CAUSE	REMEDY
When increasing throttle, speed increase slow or even decrease and stop running	Fuel supply system 1. Air in fuel line or fuel line clogged 2. Main oil flow hole is not adjusted properly 3. In carburetor, needle valve hole and main oil flow hole clogged 4. Fuel cock is clogged up 5. Too much carbon deposit in combusting chamber 6. Too much carbon fouling in muffler and exhaust pipe. 7. Air cleaner is clogged up 8. Intake pipe is leaking	1. Exhaust air or dredge fuel line 2. Readjust 3. Clean and blow to get through 4. Clean, replace damaged part 5. Clear away 6. Clear away 7. Clean air cleaner filter element 8. Repair or replace
	Poor compression 1. Piston or cylinder or piston ring is worn 2. Air leakage from the surface by which cylinder block contacting with cylinder head. 3. Too big or too small valve clearance 4. Valve tightness is poor	1. Replace the worn 2. Replace the cylinder gasket 3. Readjust 4. Repair

Gasoline Engine Can not Running Smoothly

TROUBLE	CAUSE	REMEDY
Knocking sound	1. Piston, cylinder or piston ring is worn excessively 2. Piston pin and piston pin hole are worn excessive 3. Tie rod small head is worn excessively 4. Roller bearing for crankshaft main shaft is worn	1. Replace the worn 2. Replace piston or piston pin 3. Replace tie rod 4. Replace roller bearing
Abnormal combustion	1. Engine is too hot 2. Too much carbon deposit in combustion chamber 3. Improper gasoline brand or low gasoline quality	1. Shoot trouble 2. Clear away 3. Replace with qualified gasoline
Spark lacking	1. There is water in float chamber 2. Improper spark plug electrodes clearance 3. Something wrong with induced coil, and so on	1. Clean 2. Adjust 3. Check and replace damaged parts

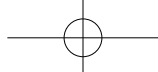

Stop Suddenly When Running

TROUBLE	CAUSE	REMEDY
Stop suddenly when running	Fuel supply system 1. Fuel is finished 2. Carburetor is clogged 3. Float chamber is leaking 4. Needle valve is stucked	1. Refill fue 2. Check fuel line and dredge 3. Repair 4. Dismantle float chamber and eliminate it
	Ignition system 1. Spark plug is punctured, or short-circuited by carbon deposit 2. Side electrode of spark plug is dropped out 3. High-tension wire is dropped out 4. Ignition coil is punctured or short-circuited 5. Parking wire is located on engine body	1. Replace spark plug 2. Replace spark plug 3. Weld on 4. Replace ignition coil 5. Find out meeting and insulate
	The other 1. Cylinder is seriously scored and valve dropped out	1. Repair or replace damaged parts

Gasoline Engine Is Overheat

TROUBLE	CAUSE	REMEDY
Gasoline engine is overheat	1. Oil insufficient or wrong oil ratio in the gasoline 2. Exhaust pipe blocked up 3. Shroud leaking 4. Cooling fins blocked by foreign matter 5. Cooling fan loosen and misfunction 6. Connection rod deformation to make piston and cylinder bushing side wear 7. Cylinder or piston or piston ring is worn to make hunting between cylinder and crankcase 8. Improper adjustment of engine governor to produce speed high 9. Crankshaft main bearing burnt out	1. Refill engine oil 2. Clean exhaust pipe 3. Repair damaged part 4. Clear cooling fins 5. Reinstall well 6. Replace connection rod 7. Replace the won parts 8. Readjust engine governor 9. Replace main bearing

Abnommal Noise Exist When Engine Running

TROUBLE	CAUSE	REMEDY
Beating sound	<ol style="list-style-type: none"> 1. Piston, piston ring or cylinder is worn 2. Connection rod or piston pin and piston pin hole are worn 3. Crankshaft main neck is worn 4. Piston ring is broken 	<ol style="list-style-type: none"> 1. Replace the worn part 2. Replace the worn part 3. Replace bearing 4. Replace piston ring
Metal beating sound when abnormal combustion occurs	<ol style="list-style-type: none"> 1. Too much carbon deposit in combusting chamber 2. Too small electrode clearance of spark plug 3. Engine fuel is too much 4. Improper fuel brand 5. Engine is overheat 	<ol style="list-style-type: none"> 1. Clear away carbon deposit 2. Adjust electrode clearance properly 3. Check relative parts such as carburetor 4. Replace fuel 5. Find a cause and eliminate it
The other	<ol style="list-style-type: none"> 1. Improper valve clearance 2. Fly wheel is not connected with crankshaft tightly 	<ol style="list-style-type: none"> 1. Readjust valve clearance properly 2. Connect tightly

TECHNICAL & CONSUMER INFORMATION

SERIAL NUMBER LOCATION

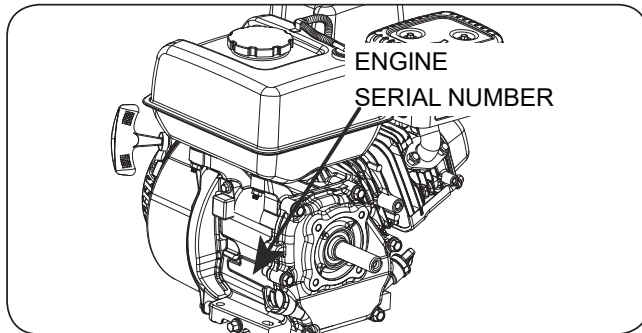

Record the engine serial number in the space below. You will need this serial number when ordering parts, and when making technical or warranty inquiries.

Engine serial number: _____

CARBURETOR MODIFICATION FOR HIGH ALTITUDE OPERATION

At high altitude, the standard carburetor air-fuel mixture will be too rich. Performance will decrease, and fuel consumption will increase. A very rich mixture will also foul the spark plug and cause hard starting. Operation at an altitude that differs from that at which this engine was certified, for extended periods of time, may increase emissions.

High altitude performance can be improved by specific modifications to the carburetor. If you always operate your engine at altitudes above 5,000 feet (1,500 meters), have your servicing dealer perform this carburetor modification. This engine, when operated at high altitude with the carburetor modifications for high altitude use, will meet each emission standard throughout its useful life.

Even with carburetor modification, engine horsepower will decrease about 3.5% for each 1,000-foot (300-meter) increase in altitude. The effect of altitude on horsepower will be greater than this if no carburetor modification is made.

⚠ WARNING *When the carburetor has been modified for high altitude operation, the air-fuel mixture will be too lean for low altitude use. Operation at altitudes below 5,000 feet (1,500 meters) with a modified carburetor may cause the engine to overheat and result in serious engine damage. For use at low altitudes, have your servicing dealer return the carburetor to original factory specifications.*

OXYGENATED FUELS

Some conventional gasolines are being blended with alcohol or an ether compound. These gasolines are collectively referred to as oxygenated fuels.

To meet clean air standards, some areas use oxygenated fuels to help reduce emissions.

If you use an oxygenated fuel, be sure it is unleaded and meets the minimum octane rating requirement.

Before using an oxygenated fuel, try to confirm the fuel's contents. Some areas require this information to be posted on the pump.

The following are the EPA approved percentages of oxygenates:

ETHANOL (ethyl or grain alcohol) 10% by volume

You may use gasoline containing up to 10% ethanol by volume. Gasoline containing ethanol may be marketed under the name "Gasohol".

MTBE (methyl tertiary butyl ether) 15% by volume

You may use gasoline containing up to 15% MTBE by volume.

METHANOL (methyl or wood alcohol) 5% by volume

You may use gasoline containing up to 5% methanol by volume, as long as it also contains cosolvents and corrosion inhibitors to protect the fuel system. Gasoline containing more than 5% methanol by volume may cause starting and/or performance problems. It may also damage metal, rubber, and plastic parts of your fuel system.

If you notice any undesirable operating symptoms, try another service station, or switch to another brand of gasoline.

Fuel system damage or performance problems resulting from the use of an oxygenated fuel containing more than the percentages of oxygenates mentioned above are not covered under warranty.

SOURCE OF EMISSIONS

The combustion process produces carbon monoxide, oxides of nitrogen, and hydrocarbons. Control of hydrocarbons and oxides of nitrogen is very important because, under certain conditions, they react to form photochemical smog when subjected to sunlight. Carbon monoxide does not react in the same way, but it is toxic.

This utilizes lean carburetor settings and other systems to reduce the emissions of carbon monoxide, oxides of nitrogen and hydrocarbons.

Tampering and Altering

Tampering with or altering the emission control system may increase emissions beyond the legal limit. Among those acts that constitute tampering are:

- Removal or alteration of any part of the intake, fuel or exhaust systems.
- Altering or defeating the governor linkage or speed-adjusting mechanism to cause the engine to operate outside its design parameters.

PROBLEMS THAT MAY AFFECT EMISSIONS

If you are aware of any of the following symptoms, have your engine inspected and repaired by your servicing dealer.

- Hard starting or stalling after starting.
- Rough idle.
- Misfiring or backfiring under load.
- Afterburning (backfiring).
- Black exhaust smoke or high fuel consumption.

REPLACEMENT PARTS

The emission control systems on your engine were designed, built. We recommend the use of genuine parts whenever you have maintenance done. These original-design replacement parts are manufactured to the same standards as the original parts, so you can be confident of their performance. The use of replacement parts that are not of the original design and quality may impair the effectiveness of your emission control system.

A manufacturer of an aftermarket part assumes the responsibility that the part will not adversely affect emission performance. The manufacturer or rebuilder of the part must certify that use of the part will not result in a failure of the engine to comply with emission regulations.

MAINTENANCE

Follow the maintenance schedule. Remember that this schedule is based on the assumption that your machine will be used for its designed purpose. Sustained high-load or high-temperature operation, or use in unusually wet or dusty conditions, will require more frequent service.

ENGINE TUNE-UP

ITEM	SPECIFICATION
Spark plug gap	0.028-0.031 in (0.70 mm -0.80 mm)
Valve clearance	IN: 0.10 mm±0.02 mm (cold) EX: 0.10 mm±0.02 mm (cold)
Other specifications	No other adjustments needed

PUBLICATIONS

These publications will give you additional information for maintaining and repairing your engine. You may order them from your engine dealer.

QUICK REFERENCE INFORMATION

Engine Oil	Type	SAE 10W-30,API SE or SF, for general use
	Capacity	R210-S: 0.5 L
Spark Plug	Type	F6TC/F6RTC/F7TC/F7RTC
	Gap	0.028-0.031 in (0.70 mm-0.80 mm)
Maintenance	Each use	Check engine oil. Check air filter.
	First 20 hours	Change engine oil.
	Subsequent	Refer to the maintenance

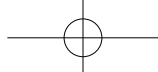

WIRING DIAGRAMS

Bl	BLACK
Y	YELLOW
W	WHITE

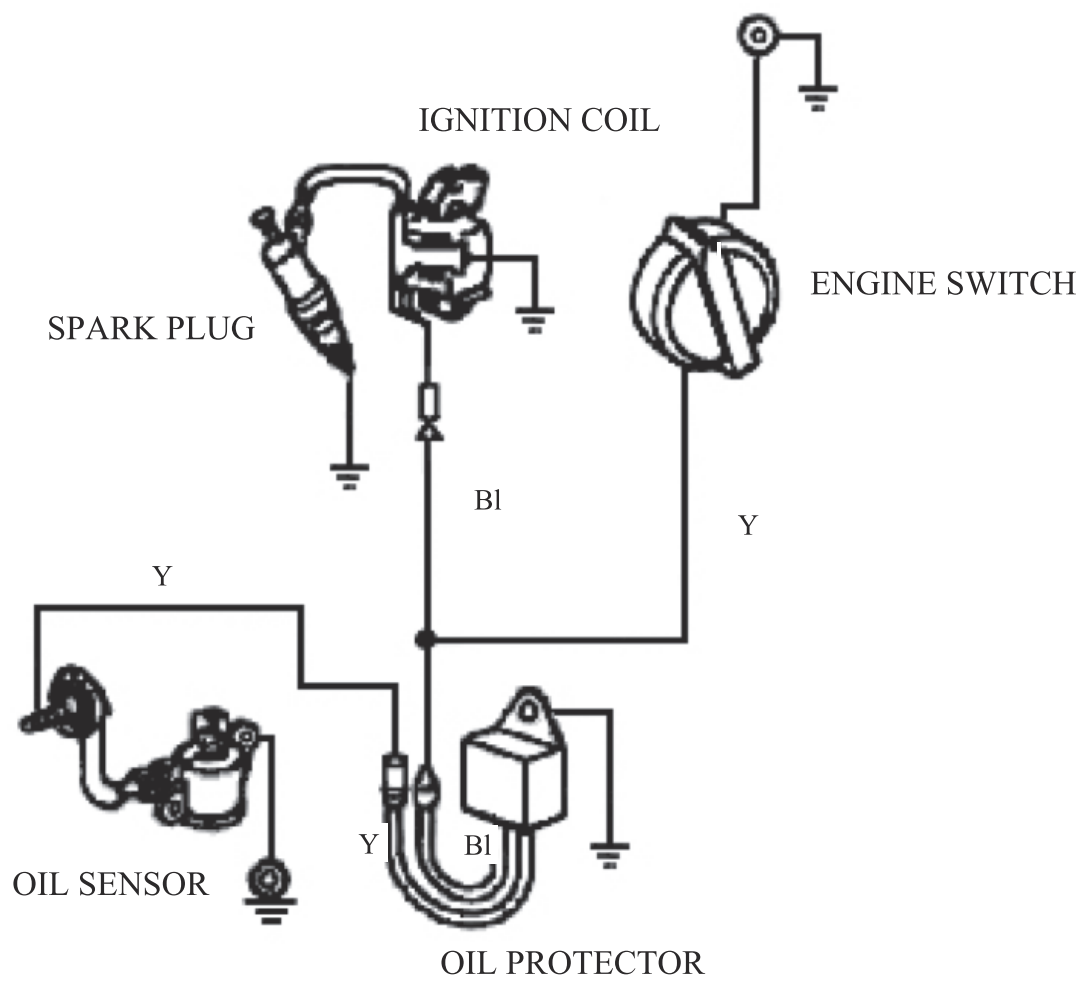

CALIFORNIA AND FEDERAL EXHAUST AND EVAPORATIVE EMISSIONS CONTROL WARRANTY STATEMENT

YOUR WARRANTY RIGHTS AND OBLIGATIONS

- The California Air Resources Board, the United States Environmental Protection Agency and FULL BOAR, are pleased to explain the exhaust and evaporative emissions ("emissions") control system warranty on your 2025/2026 small off-road engine/equipment. In California, new equipment that use small off-road engines must be designed, built, and equipped to meet the State's stringent anti-smog standards. FULL BOAR must warrant the emissions control system on your small off-road engine/equipment for the period listed below provided there has been no abuse, neglect or improper maintenance of your small off-road engine/equipment leading to the failure of the emissions control system.
- Your emissions control system may include parts such as the carburetor or fuel-injection system, the ignition system, catalytic converter, fuel tanks, fuel lines (for liquid fuel and fuel vapors), fuel caps, valves, canisters, filters, clamps and other associated components. Also included may be hoses, belts, connectors, and other emission-related assemblies.
- Where a warrantable condition exists, FULL BOAR will repair your small off-road engine/equipment at no cost to you including diagnosis, parts and labor.

MANUFACTURER'S WARRANTY COVERAGE:

- The exhaust and evaporative emissions control system on your small off-road engine/equipment is warranted for two years. If any emissions-related part on your small off-road engine/equipment is defective, the part will be repaired or replaced by FULL BOAR.

OWNER'S WARRANTY RESPONSIBILITIES:

- As the small off-road engine/equipment owner, you are responsible for performance of the required maintenance listed in your owner's manual. FULL BOAR recommends that you retain all receipts covering maintenance on your small off-road engine/equipment, but FULL BOAR cannot deny warranty coverage solely for the lack of receipts or for your failure to ensure the performance of all scheduled maintenance.
- As the small off-road engine/equipment owner, you should however be aware that FULL BOAR may deny you warranty coverage if your small off-road engine/equipment or a part has failed due to abuse, neglect, or improper maintenance or unapproved modifications.

- You are responsible for presenting your small off-road engine/equipment to a FULL BOAR distribution center or service center as soon as the problem exists. The warranty repairs shall be completed in a reasonable amount of time, not to exceed 30 days.
- If you have any questions regarding your warranty rights and responsibilities, you should contact FULL BOAR. at (888) 533-2999. The nationwide service E_mail is support@gofullboar.com.

DEFECTS WARRANTY REQUIREMENTS:

- The warranty period begins on the date the small off-road engine/equipment is delivered to an ultimate purchaser.
- General Emissions Warranty Coverage. FULL BOAR warrants to the ultimate purchaser and each subsequent owner that the engine or equipment is:
 - (1) Designed, built, and equipped so as to conform with all applicable regulations adopted by the Air Resources Board; and
 - (2) Free from defects in materials and workmanship that causes the failure of a warranted part for a period of two years.
- The warranty on emission-related parts will be interpreted as follows:
 - (1) Any warranted part that is not scheduled for replacement as required maintenance in the written instructions must be warranted for the warranty period defined in Subsection (b)(2). If any such part fails during the period of warranty coverage, it must be repaired or replaced by FULL BOAR according to Subsection (4) below. Any such part repaired or replaced under the warranty must be warranted for the remaining warranty period.
 - (2) Any warranted part that is scheduled only for regular inspection in the written instructions must be warranted for the warranty period defined in Subsection (b)(2). A statement in such written instructions to the effect of "repair or replace as necessary" shall advise owners of the warranty coverage for emissions related parts. Replacement within the warranty period is covered by the warranty and will not reduce the period of warranty coverage. Any such part repaired or replaced under warranty must be warranted for the remaining warranty period.

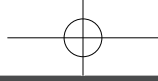

- (3) Any warranted part that is scheduled for replacement as required maintenance in the written instructions must be warranted for the period of time prior to the first scheduled replacement point for that part. If the part fails prior to the first scheduled replacement, the part must be repaired or replaced by FULL BOAR according to Subsection (4) below. Any such part repaired or replaced under warranty must be warranted for the remainder of the period prior to the first scheduled replacement point for the part.
- (4) Repair or replacement of any warranted part under the warranty provisions must be performed at no charge to the owner at a warranty station.
- (5) Notwithstanding the provisions of Subsection (4) above, warranty services or repairs must be provided at distribution centers that are franchised to service the subject engine/equipment.
- (6) The owner must not be charged for diagnostic labor that leads to the determination that a warranted part is in fact defective, provided that such diagnostic work is performed at a warranty station.
- (7) FULL BOAR is liable for damages to other engine/equipment components proximately caused by a failure under warranty of any warranted part.
- (8) Throughout the emissions control system's warranty period set out in subsection (b)(2), FULL BOAR must maintain a supply of warranted parts sufficient to meet the expected demand for such parts and must obtain additional parts if that supply is exhausted.
- (9) Manufacturer-approved replacement parts that do not increase the exhaust or evaporative emissions of the engine or emissions control system must be used in the performance of any warranty maintenance or repairs and must be provided without charge to the owner. Such use will not reduce the warranty obligations of FULL BOAR.
- (10) Add-on or modified parts that are not exempted by the Air Resources Board may not be used. The use of any non-exempted add-on or modified parts will be grounds for disallowing a warranty claim. FULL BOAR will not be liable to warrant failures of warranted parts caused by the use of a non-exempted add-on or modified part.
- (11) FULL BOAR issuing the warranty shall provide any documents that describe that warranty procedures or policies within five working days of request by the Executive Officer.

● Emission Warranty Parts List for Exhaust

- (1) Fuel Metering System
 - (i) Carburetor and internal parts (and/or pressure regulator or fuel injection system).
 - (ii) Air/fuel ratio feedback and control system.
 - (iii) Cold start enrichment system.
- (2) Air Induction System
 - (i) Controlled hot air intake system.
 - (ii) Intake manifold.
 - (iii) Air filter.
- (3) Ignition System
 - (i) Spark Plugs.
 - (ii) Magneto or electronic ignition system.
 - (iii) Spark advance/retard system.
- (4) Exhaust Gas Recirculation (EGR) System
 - (i) EGR valve body, and carburetor spacer if applicable.
 - (ii) EGR rate feedback and control system.
- (5) Air Injection System
 - (i) Air pump or pulse valve.
 - (ii) Valves affecting distribution of flow.
 - (iii) Distribution manifold.
- (6) Catalyst or Thermal Reactor System
 - (i) Catalytic converter.
 - (ii) Thermal reactor.
 - (iii) Exhaust manifold.
- (7) Particulate Controls
 - (i) Traps, filters, precipitators, and any other device used to capture particulate emissions.
- (8) Miscellaneous Items Used in Above Systems
 - (i) Electronic controls.
 - (ii) Vacuum, temperature, and time sensitive valves and switches.
 - (iii) Hoses, belts, connectors, and assemblies.

- Emission Warranty Parts List for Evap
 - (1) Fuel Tank
 - (2) Fuel Cap
 - (3) Fuel Lines (for liquid fuel and fuel vapors)
 - (4) Fuel Line Fittings
 - (5) Clamps*
 - (6) Pressure Relief Valves*
 - (7) Control Valves*
 - (8) Control Solenoids*
 - (9) Electronic Controls*
 - (10) Vacuum Control Diaphragms*
 - (11) Control Cables*
 - (12) Control Linkages*
 - (13) Purge Valves*
 - (14) Gaskets*
 - (15) Liquid/Vapor Separator
 - (16) Carbon Canister
 - (17) Canister Mounting Brackets
 - (18) Carburetor Purge Port Connector

*Note: As they relate to the evaporative emission control system.

FULL BOAR will furnish with each new small off-road engine/equipment written instructions for the maintenance and use of the engine/equipment by the owner.

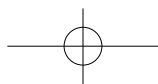
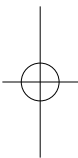
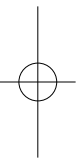
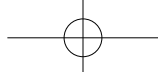

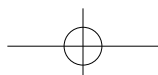
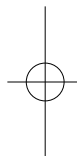
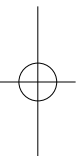
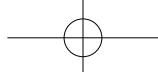

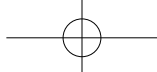

gofullboar.com



GO FULL BOAR

(888) 533-2999 | Support@gofullboar.com

