

ASSEMBLY INSTRUCTION

INSTRUCTIONS D'ASSEMBLEMENT

ITEM NO: N752P342928



ATTENTION:

1. Check to ensure all parts and hardware are present.
- 2. We have provided Extra Hardware of A/B/C/E in case of any bolts missing in the boxes.**
3. Do not fully tighten all bolts until all parts are in place. Failure to follow these instructions may cause the bolt to misalign during assembly.



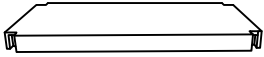
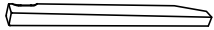
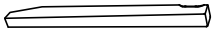
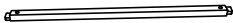

ATTENTION:

1. Vérifiez pour vous assurer que toutes les pièces et le matériel sont présents.
- 2. Nous fournissons le matériel supplémentaire de A / B / C / E en cas de perte de boulons dans la boîte.**
3. Ne serrez pas complètement tous les boulons jusqu'à ce que toutes les pièces soient en place. Le non - respect de ces instructions peut entraîner des dommages au boulon
Dislocation lors de l'assemblage.

Part List

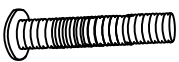
1 	2 	3 	4 	5 
Table Top x 1pc	Leg x 2pcs	Leg x 2pcs	Support Bar Panel x 1pc	Support Bar Panel x 2pcs

Hardware

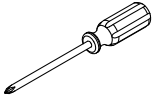
A  Ø5/16x60mm	B  Ø5/16x13mm	C  Ø5/16x19x2mm	D  4mm	E  Ø4x50mm	F 
BOLT (8PCS +1)	LOCK WASHER (8PCS + 1)	FLAT WASHER (8PCS + 1)	ALLEN KEY(1PC)	SCREW (6PCS +1)	SCREW DRIVER (1PC)

STEP1 /Étape 1:

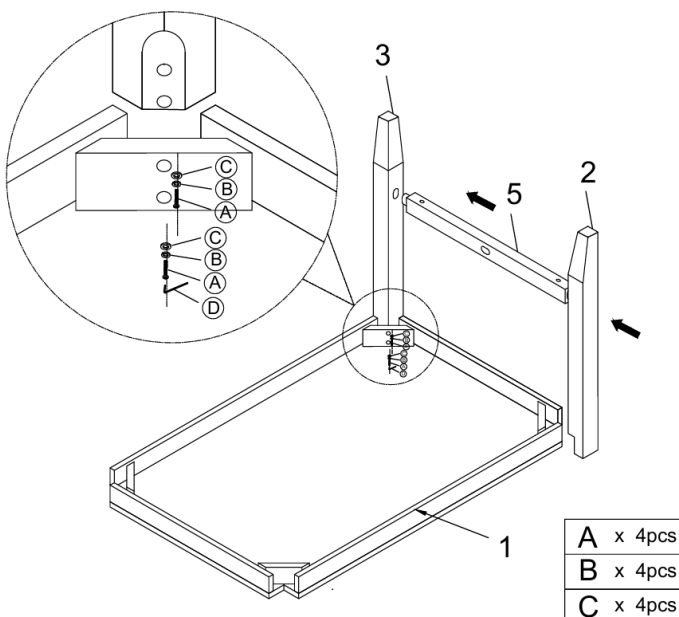

STEP2 /Étape 2:

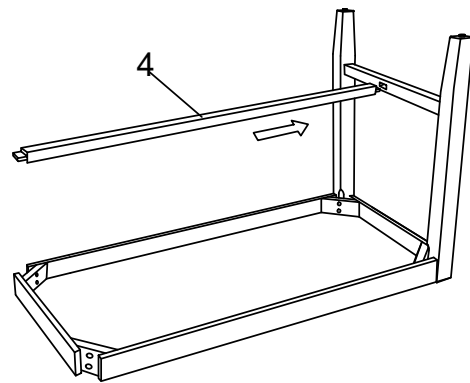

STEP3 /Étape 3:

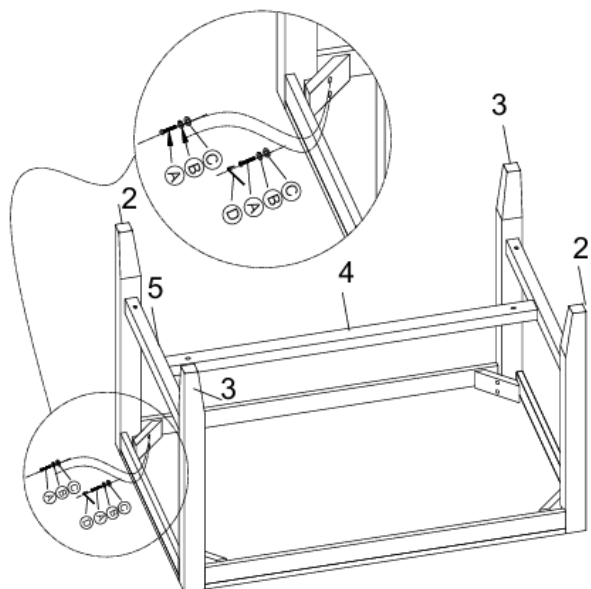

A x4PCS
B x4PCS
C x4PCS

STEP4 /Étape 4:

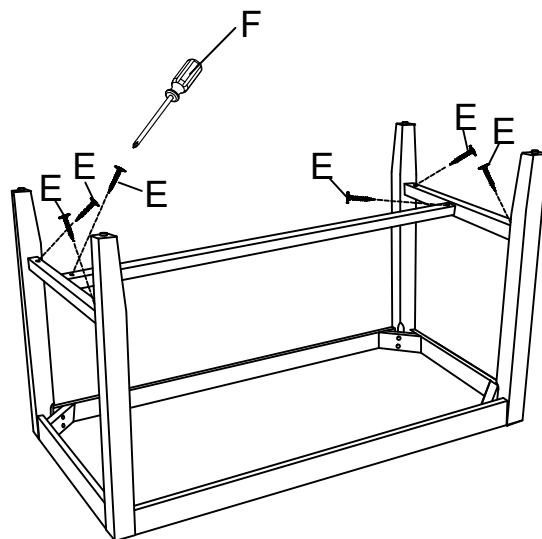

E x6PCS
F x1PC

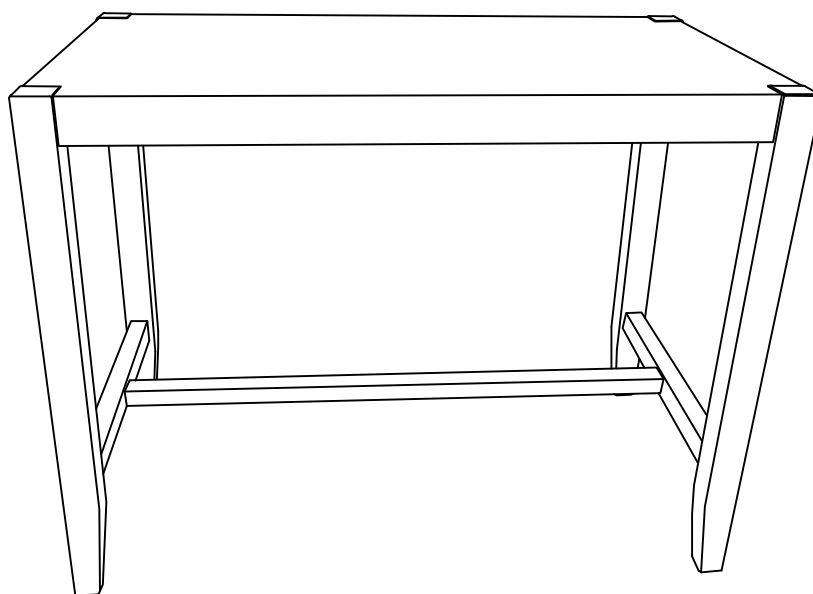

ASSEMBLY INSTRUCTION

INSTRUCTIONS D'ASSEMBLEMENT

ITEM NO: N752P342929







ATTENTION:

1. Check to ensure all parts and hardware are present.
- 2. We have provided Extra Hardware of A/B/C/D/E/F/H in case of any bolts missing in the boxes.**
3. Do not fully tighten all bolts until all parts are in place. Failure to follow these instructions may cause the bolt to misalign during assembly.

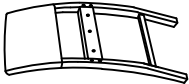







ATTENTION:

1. Vérifiez pour vous assurer que toutes les pièces et le matériel sont présents.
- 2. Nous fournissons du matériel supplémentaire pour A/B/C/D/E/F/H au cas où il manque des boulons dans la boîte.**
3. Ne serrez pas complètement tous les boulons jusqu'à ce que toutes les pièces soient en place. Le non - respect de ces instructions peut entraîner des dommages au boulon
Dislocation lors de l'assemblage.

Part List

1 	2 	3 	4 
Chair Back x 1pc	Seat Cushion x 1pc	Front Leg x 1pc	Front Leg x 1pc
5 	6 	7 	
Side Stretcher x 1pc	Back Stretcher x 1pc	Side Stretcher x 1pc	

Hardware

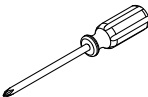
A 	B 	C 	D 	E 
Ø10*30mm	Ø1/4x38mm	Ø1/4x60mm	Ø1/4x75mm	Ø1/4x13mm
WOOD DOWEL (1PC+1)	SHORT BOLT (2PCS+1)	BOLT (4PCS+1)	LONG BOLT (4PCS+1)	LOCK WASHER (10PCS+1)
F 	G 	H 	I 	
Ø1/4x19x2mm	4mm	Ø4x45mm		
FLAT WASHER (10PCS+1)	ALLEN KEY (1PC)	SCREW (6PCS +1)	SCREW DRIVER (1PC)	

STEP1 /Étape 1:

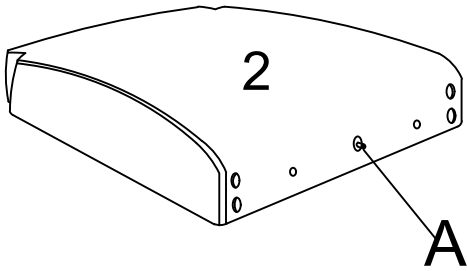

A x1PC

STEP2 /Étape 2:

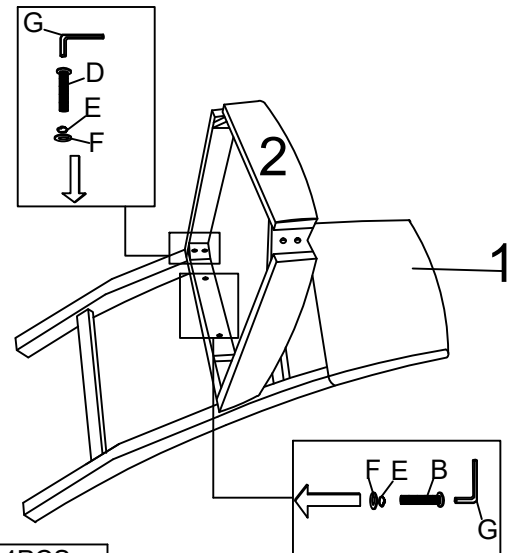

B x2PCS	D x4PCS
E x2PCS	E x4PCS
F x2PCS	F x4PCS

STEP3 /Étape 3:

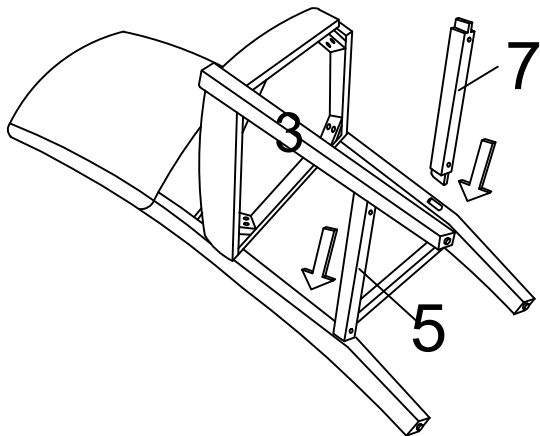

STEP4 /Étape 4:

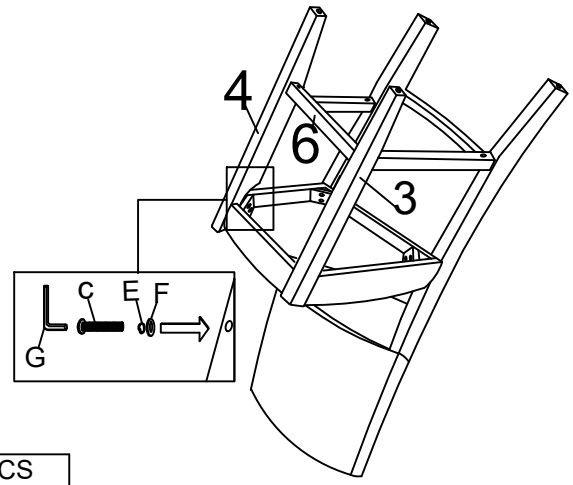

C x4PCS
F x4PCS
E x4PCS

STEP5 /Étape 5:

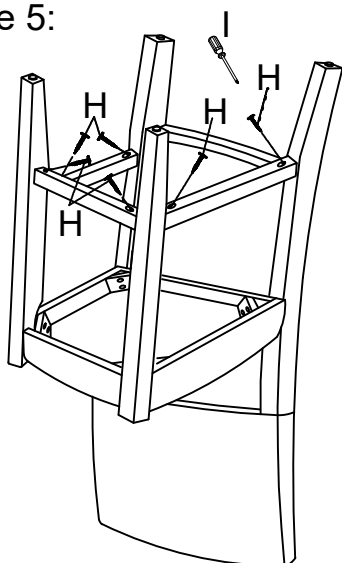

H x6PCS
I x1PCS

