

Notices de réparation, Repair manuals, Manuales de reparación, Reparaturanleitungen, Reparationshandbücher, Reparationsvejledninger, Manuais de reparo, Manuali di riparazione, Manuais de reparação, 维修手册, 修理マニュアル, Руководства по ремонту, أدلة الإصلاح, मरम्मत के निर्देश, 수리 매뉴얼, பழுது பார்க்கும் கையேடுகள்

FRANÇAIS	2
ENGLISH	21
NEDERLANDS.....	40
ESPAÑOL.....	59
PORTUGUÊS	78
日本語	97
한국어.....	116
SVENSK	135
DANSK	154
DEUTSCH	173
ITALIANO.....	192
中文	211
中国	230
हिन्दी	249
தமிழ்	268
عربي	287
ΕΛΛΗΝΙΚΑ	307

DELSEY PARIS

1 9 4 6

SCHEMATIC

SOMMAIRE

Cliquez sur la réparation qui vous concerne :

1. REMPLACEMENT D'UNE ROUE PIVOTANTE
2. REMPLACEMENT D'UNE SERRURE À COMBINAISON
3. REMPLACEMENT D'UNE SERRURE À COMBINAISON CAS MONCEY
4. REMPLACEMENT DU SYSTÈME TROLLEY EXTÉRIEUR
5. REMPLACEMENT DU SYSTÈME TROLLEY INTÉRIEUR
6. REMPLACEMENT D'UNE POIGNÉE
7. REMPLACEMENT DE LA TIRETTE DE CURSEUR
8. REMPLACEMENT DE PILES SUR POIGNÉE D'INDICATEUR DE SURPOIDS

LEXIQUE

LES OUTILS REQUIS

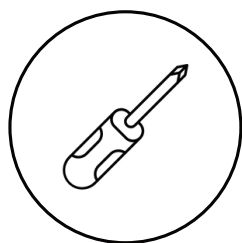

Tournevis cruciforme



Pince coupante

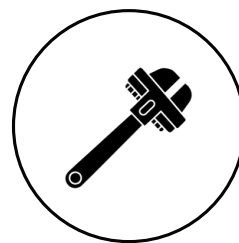

Pince multiprise



Chiffon



Tournevis plat

clause de non-responsabilité

DELSEY PARIS n'assume aucune responsabilité en cas de blessures ou de dommages résultant de ce kit de réparation ou de ces instructions, veuillez donc procéder avec prudence. Si vous avez des questions concernant ces instructions, vous pouvez toujours contacter le service clientèle à n'importe quelle étape du processus de réparation et nous vous aiderons !

REPLACEMENT D'UNE ROUE PIVOTANTE 4 MINUTES

OUTILS REQUIS

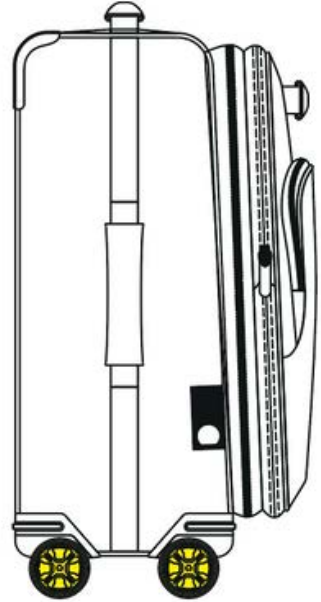

Exemple de roue montée

1



Ouvrez complètement votre valise et dépliez-la en deux sur le sol, en veillant à ce que les deux compartiments soient bien à plat...



... pour avoir un accès facilité à la doublure.

2



Retirez la/ les vis de maintien de la roue.

3



Retirez la roue et fixez la nouvelle pièce en sens inverse (par l'intérieur) et remettez en place toutes les vis en serrant.

4



Pour finir, refermez la doublure et le bagage.

REPLACEMENT D'UNE SERRURE TSA 3 MINUTES

OUTILS REQUIS

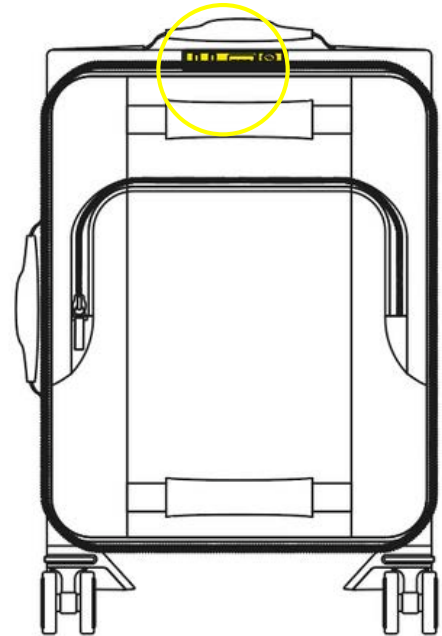

Exemple de serrure montée

1



Ouvrez complètement votre valise et déployez-la en deux sur le sol, en veillant à ce que les deux compartiments soient bien à plat...

... pour avoir un accès facilité à la doublure.

2



Accédez à la contreplaque de la fixation sous la doublure (les têtes de vis peuvent être protégées sous un scotch).



Démontez les vis de la contreplaque.

3



Retirez la serrure endommagée. Une fois la serrure retirée, **fixez ensuite la nouvelle serrure** en vissant les vis dans le sens inverse de l'extraction (**par l'intérieur**). Et repositionnez la contre plaque (déviscée en point 2).

4



Pour finir, refermez la doublure et le bagage.

REEMPLACEMENT DE LA SERRURE POUR LES VALISES MONCEY - 10 MINUTES

OUTILS REQUIS



1



Ouvrez complètement votre valise et déployez-la en deux sur le sol, en veillant à ce que les deux compartiments soient bien à plat...



Ouvrez la doublure, dévisser les 2 vis au-dessous à l'arrière de la serrure.

2



Déclipsez la doublure qui est maintenue par 1 petite pièce plastique de chaque côté de la serrure.

3



Dévissez les 2 vis à présent accessibles.

4



Retirez le bloc poignée/serrure en tirant vers le bas.

5



Mettez en place la nouvelle poignée/serrure.

6



Veillez à bien la bloquer en hauteur contre la coque.

7



Remettez toutes les vis en place + les 2 petits clips de maintien de la doublure.

8



Pour finir, refermez la doublure puis le Zip de la valise.

REPLACEMENT DU SYSTÈME TROLLEY EXTÉRIEUR - 5 MINUTES

OUTILS REQUIS

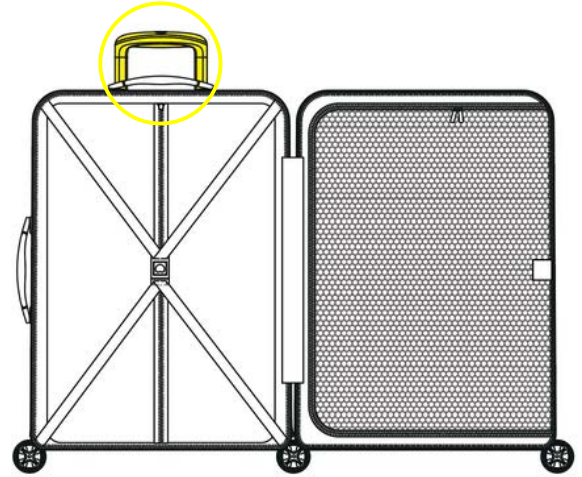
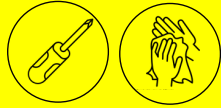

1



Ajustez le système Trolley au premier cran, pour faciliter son extraction.

2



Ouvrez complètement votre valise et déployez-la en deux sur le sol, en veillant à ce que les deux compartiments soient bien à plat ...

... pour avoir un accès facilité à la doublure.

3



Démontez les vis du haut.

4



Démontez les vis du bas.

5



Conservez toutes les vis et pièces d'origine.

6



Retirez la pièce par l'extérieur et remontez la nouvelle pièce en sens inverse (par l'intérieur).

7



Pour finir, refermez la doublure puis le Zip de la valise.

REPLACEMENT DU SYSTÈME TROLLEY INTÉRIEUR - 7 MINUTES

OUTILS REQUIS

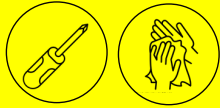

1

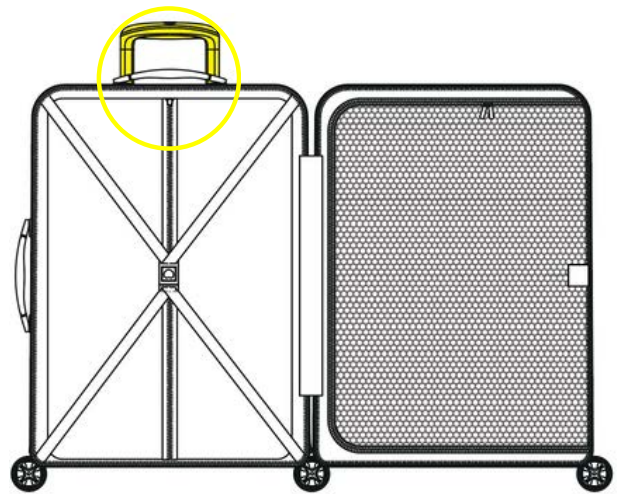

Ouvrez complètement votre valise et déployez-la en deux en veillant à ce que les deux compartiments soient bien à plat, pour avoir un accès facilité à la doublure.

2



Dévissez les vis du haut et du bas qui maintiennent le système trolley.

3



Installez le nouveau système trolley en le fixant à l'aide de la contreplaque et des vis retirées.

4



Pour finir, refermez la doublure puis votre bagage.

REEMPLACEMENT D'UNE POIGNÉE 4 MINUTES

OUTILS REQUIS



Exemple de poignée montée

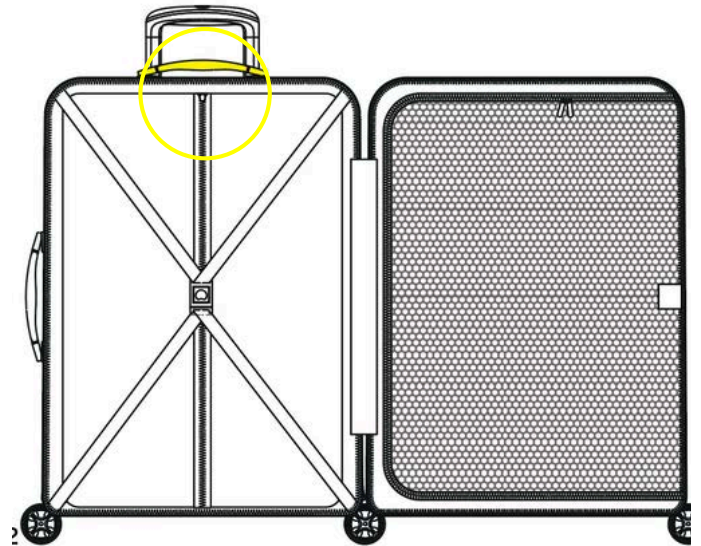

1



Ouvrez complètement votre valise et dépliez-la en deux sur le sol, en veillant à ce que les deux compartiments soient bien à plat ...



... pour avoir un accès facilité à la doublure.

2



Dévissez les vis de maintien de la poignée (tête de vis possiblement masquée par du **scotch de protection**).

3



Retirez la poignée par l'extérieur et fixez la nouvelle pièce dans le sens inverse (par l'intérieur). Puis remettez **en place** toutes les vis en serrant.

4



Pour finir, refermez la doublure puis le Zip de la valise.

REMPACEMENT DE LA TIRETTE DE CURSEUR - 7 MINUTES

OUTILS REQUIS

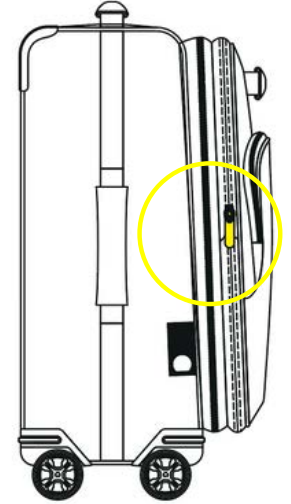

1



Coupez la tirette endommagée avec une pince coupante ou tenaille en prenant soin de ne pas **endommager** le pont de curseur.

2



Soulevez délicatement le pont de curseur d'1 ou 2 mm à l'aide d'un tournevis plat pour pouvoir **enclencher** la nouvelle tirette.

3



Refermez le pont de curseur à l'aide d'une pince multiprise (protégez les dents de la pince à l'aide d'un scotch épais afin de ne pas griffer le pont).

REPLACEMENT DE PILES SUR UNE POIGNÉE D'INDICATEUR DE SURPOIDS - 3 MIN

OUTILS REQUIS

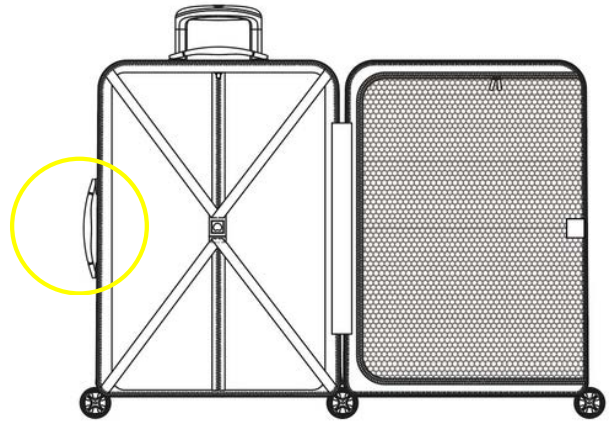

Ouvrez complètement votre valise, et dépliez-la en deux sur le sol, en veillant à ce que les deux compartiments soient bien à plat ...



... pour avoir un **accès facilité à la doublure**.

2



Ouvrez soigneusement la doublure intérieure pour permettre un accès direct à la **contreplaque** de la poignée., et en veillant à ne pas endommager le matériau ou les coutures environnantes



À l'arrière de la poignée, une petite trappe intégrée permet d'accéder facilement aux **deux piles bouton**.



Ouvrez délicatement cette petite trappe située à l'arrière de la poignée et **remplacez** les deux piles bouton usagées par des neuves, en veillant à bien **respecter** la polarité indiquée (+/-).



Pour finir, refermez le clapet de la petite trappe, Vous devriez entendre un "clic". Refermez la doublure puis le Zip de la valise.

SUMMARY

Click on the type of repair that you would like to do :

1. REPLACEMENT OF A CASTER WHEEL
2. REPLACEMENT OF A COMBINATION LOCK
3. REPLACEMENT OF A COMBINATION LOCK CASE MONCEY
4. REPLACEMENT OF THE EXTERNAL TROLLEY SYSTEM
5. REPLACEMENT OF THE INTEGRATED TROLLEY SYSTEM
6. REPLACEMENT OF A HANDLE
7. REPLACEMENT OF A SLIDER PULL
8. REPLACEMENT OF BATTERIES ON AN OVERWEIGHT INDICATOR HANDLE

LEXIQUE

TOOLS

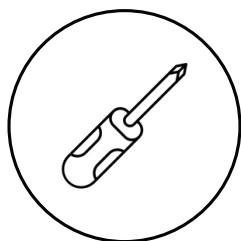

Screwdriver cruciform



Pliers Cutting

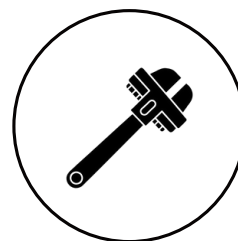

Pliers power strip



Rag



Screwdriver flat

DISCLAIMER

DELSEY PARIS does not assume liability for injury or damages resulting from this DIY repair kit or these instructions, so please proceed with caution. If you have any questions about these instructions, you can always reach customer service at any stage of the repair process and we'll help you through it! 23

REPLACEMENT OF A CASTER WHEEL 4 MINUTES

REQUIRED TOOLS

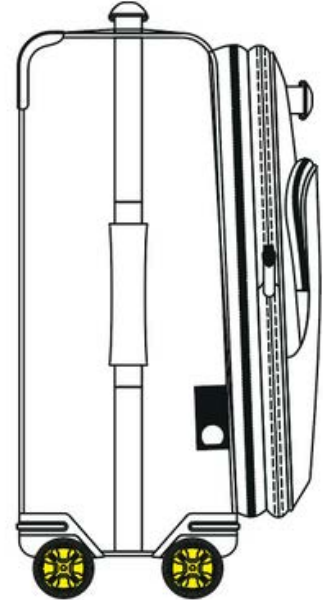

Example of a wheel assembly

1



Please open your suitcase fully and unfold it in half on the floor, ensuring the two compartments are flat...



... to allow easy access to the lining.

DELSEY PARIS

1 9 4 6

2



Then remove the retaining screw(s) from the wheel.

3



Remove the wheel and attach the new part in the opposite direction (from the inside) and tighten all the screws back into place.

4



Finally, close the lining and the luggage.

REPLACEMENT OF A COMBINATION LOCK 3 MINUTES

REQUIRED TOOLS

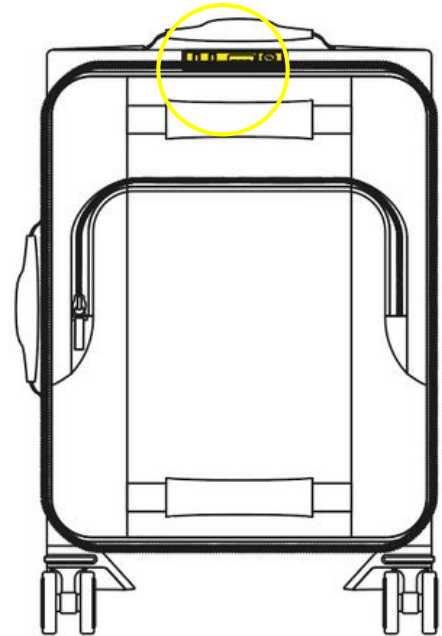
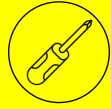

Example of a lock assembly

1



Open your suitcase fully and unfold it in half on the floor, ensuring the two compartments are flats.

... to allow easy access to the lining.

2



Access the plywood of the fastener under the liner (the screw heads should be protected under tape to avoid the risk of dislodging).



Remove the screws from the plywood.

3



Remove the damaged lock. Once the lock has been removed, then fix the new lock by screwing the screws in the opposite direction of extraction (from the inside). reposition the counter plate (unscrewed at point 2).

4



And finally, close the lining and the luggage

REPLACEMENT OF A COMBINATION LOCK CASE MONCEY - 10 MINUTES

REQUIRED TOOLS



1



Open your suitcase completely and unfold it in half on the floor, making sure that the two compartments are flat...



Unclip the liner which is held in place by 1 small plastic piece on each side of the lock.

2



Open the liner, unscrew the 2 screws below on the back of the lock.

3



Unscrew the 2 screws that are now accessible.

4



Remove the handle/lock block by pulling downwards.

5



Install the new handle/lock.

6



Make sure to lock it high up against the shell

7



Put all the screws back in place + the 2 small clips holding the lining.

8



Finally, close the lining then the Zip of the suitcase.

REPLACEMENT OF THE EXTERNAL TROLLEY SYSTEM - 5 MINUTES

REQUIRED TOOLS

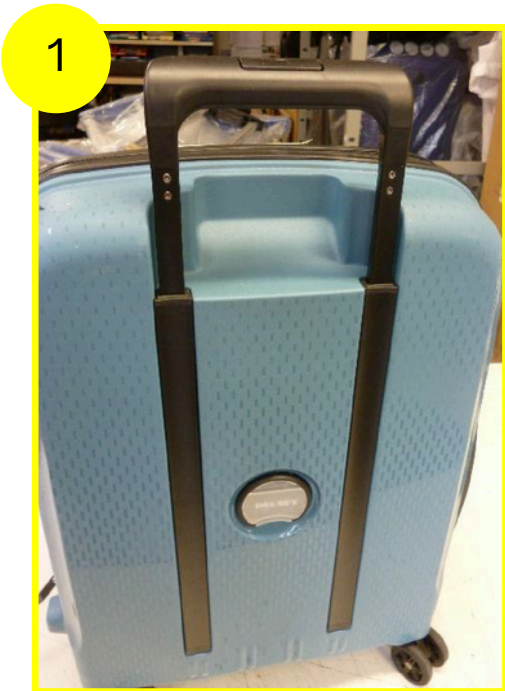
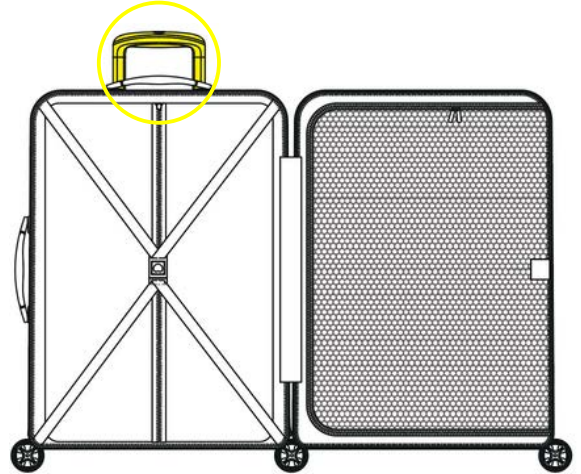

Adjust the Trolley system to the first notch, to make it easier to extract.



Open your suitcase completely and unfold it in half on the floor, making sure that both compartments are flat ...

... for easy access to the lining.

DELSEY PARIS

1946

3



Remove the top screws

4



Remove the bottom screws.

5



Keep all original screws and parts.

6



Remove the part from the outside and reassemble the new part in the opposite direction (from the inside).

7



Finally, close the lining then the Zip of the suitcase.

REPLACEMENT OF THE INTEGRATED TROLLEY SYSTEM - 7 MINUTES

REQUESTED TOOLS

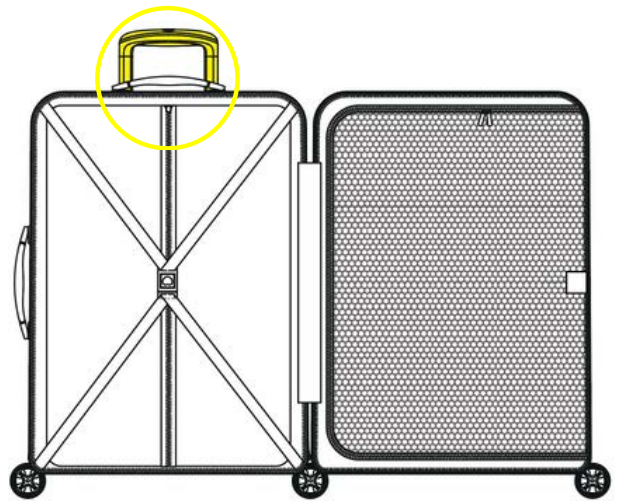

Open your suitcase completely and unfold it in half, making sure that the two compartments are flat, for easy access to the lining.

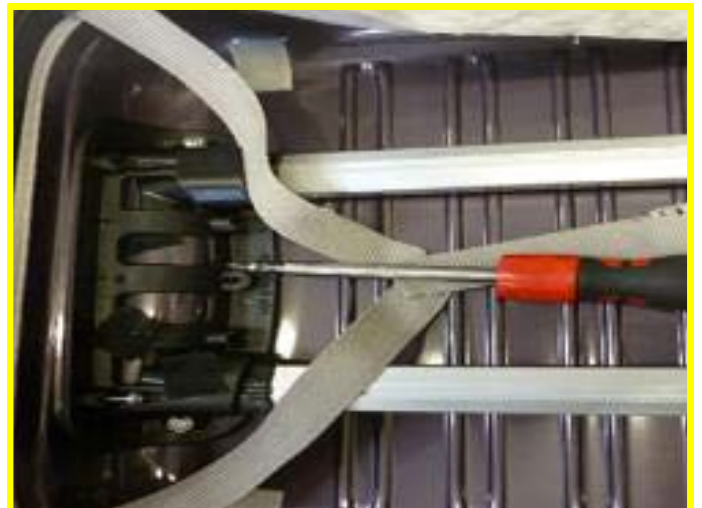

Unscrew the top and bottom screws that hold the trolley system.

DELSEY PARIS

1 9 4 6

3



Install the new trolley system by securing it with the plywood and the removed screws.

4



To finish Close the lining and then your luggage.

REPLACEMENT OF A HANDLE 4 MINUTES

REQUESTED TOOL



Example of a fixed handle

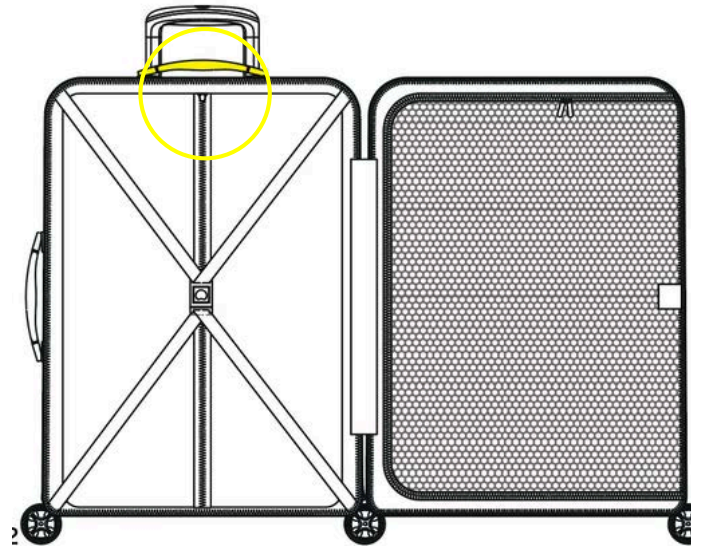

1



Open your suitcase completely and unfold it in half on the floor, ensuring that both side lay flat.

... for an easy access to the lining

DELSEY PARIS

1946

2



Unscrew the screws holding the handle (screw head possibly hidden by protective tape).

3



Remove the handle from the outside and attach the new part in the opposite direction (from the inside). Then put all the screws back in place by tightening.

4



Finally, close the lining then the suitcase zipper.

REPLACEMENT OF A SLIDER PULL - 7 MINUTES

REQUIRED TOOLS

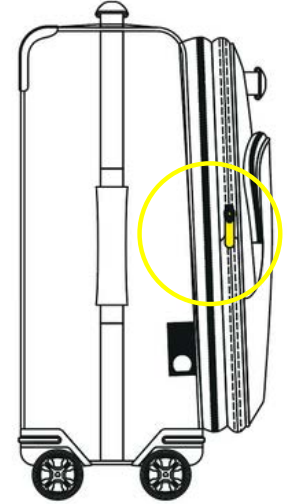
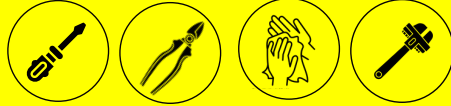

1



Cut the damaged zipper with wire cutters or folders, taking care not to damage the slider bridge.

2



Gently lift the slider bridge 1 or 2 mm with a flat head screwdriver so that the new zipper puller can be fitted.



Check the direction of the direction of the part before hand: right or left. Close the slider bridge using a pair of pliers (protect the teeth of the pliers with thick tape not to scratch the bridge).

REPLACEMENT OF BATTERIES ON AN OVERWEIGHT INDICATOR HANDLE - 3 MIN

REQUIRED TOOLS

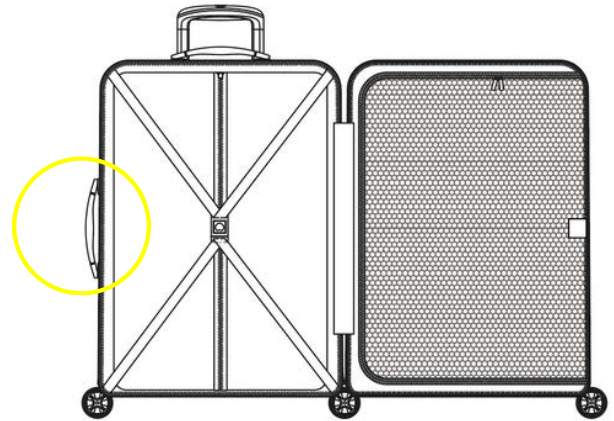

Open your suitcase completely, and unfold it in half on the floor, ensuring that the two compartments are flat...



... for easy access to the lining.



Carefully open the inner lining to allow direct access to the handle plywood, and be careful not to damage the material or surrounding seams

DELSEY PARIS

1946



On the back of the handle, a small integrated hatch provides easy access to the batteries compartment.



Carefully open this small hatch located at the back of the handle and replace the two used button batteries with new ones, making sure to respect the polarity indicated (+/-).



Finally, close the flap of the small hatch, you should hear a "click". Close the lining and then the zip of the suitcase.

samenvatting

Klik op het type reparatie dat u wilt uitvoeren:

1. VERVANGING VAN EEN ZWENKWIEL
2. VERVANGING VAN EEN COMBINATIESLOT
3. VERVANGING VAN EEN COMBINATIESLOT
GEVAL MONCEY
4. VERVANGING VAN HET EXTERNE
TROLLEYSYSTEEM
5. VERVANGING VAN DE GEÏNTEGREERDE
TROLLEY-SYSTEEM
6. VERVANGING VAN EEN HANDVAT
7. VERVANGING VAN EEN TREKKER
8. VERVANGING VAN BATTERIJEN OP EEN
OVERGEWICHTSINDICATORHENDEL

LEXICON

DE BENODIGDE GEREEDSCHAPPEN

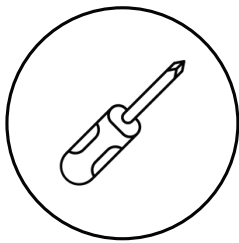

Schroevendraaier kruisvormig



snijtang



Tangste kkerdoos



Vod

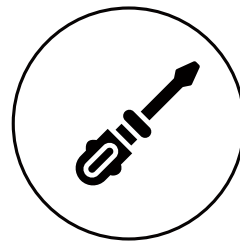

Schroevendraaier plat

DISCLAIMER

DELSEY PARIS aanvaardt geen aansprakelijkheid voor letsel of schade als gevolg van deze doe-het-zelf-reparatieset of deze instructies, dus ga voorzichtig te werk. Als je vragen hebt over deze 42 instructies, kun je altijd contact opnemen met de klantenservice in elk stadium van het reparatieproces en helpen we je er doorheen!

VERVANGING VAN EEN ZWENKWIEL 4 MINUTEN

BENODIGD GEREEDSCHAP

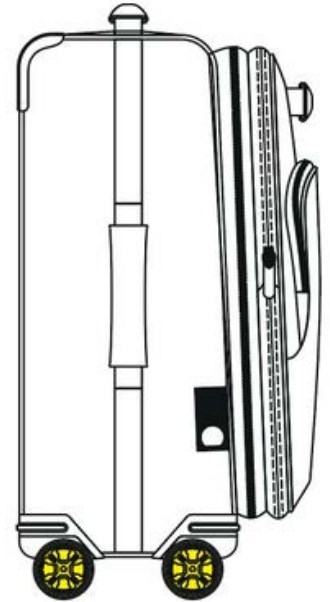

Voorbeeld van een wielmontage



Open uw koffer volledig en vouw hem dubbel op de vloer, zodat de twee compartimenten plat zijn.



...om gemakkelijke toegang tot de voering mogelijk te maken

2



Verwijder vervolgens de borgschroef(en) van het wiel.

3



Verwijder het wiel, bevestig het nieuwe onderdeel in de tegenovergestelde richting (van binnenuit) en draai alle schroeven weer vast.

4



Sluit ten slotte de voering en de bagage.

VERVANGING VAN EEN COMBINATIESLOT 3 MINUTEN

BENODIGD GEREEDSCHAP

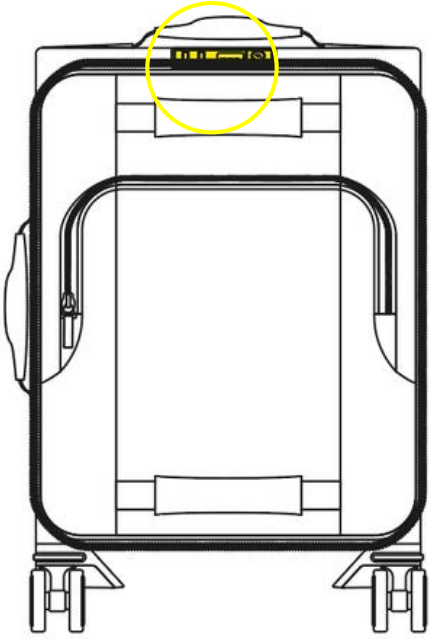

Voorbeeld van een slotmontage...

1



Open uw koffer volledig en vouw hem dubbel op de vloer, zodat de twee compartimenten plat zijn.

...om gemakkelijke toegang tot de voering mogelijk te maken.

2



Ga naar het multiplex van de bevestigiger onder de voering (de schroefkoppen moeten worden beschermd met tape om het risico van losraken te voorkomen).



Verwijder de schroeven uit het multiplex.

3



Verwijder het beschadigde slot. Nadat het slot is verwijderd, bevestigt u het nieuwe slot door de schroeven in de tegenovergestelde richting van het uittrekken (van binnenuit) te draaien. plaats de tegenplaat terug (losgeschroefd bij punt 2).

4



En sluit tenslotte de voering en de bagage.

REPLACEMENT DE LA SERRURE POUR LES VALISES MONCEY - 10 MINUTEN

BENODIGD GEREEDSCHAP

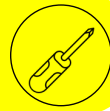

Open je koffer helemaal en vouw hem dubbel op de grond, zorg ervoor dat de twee compartimenten plat zijn...



Maak de voering los, die op zijn plaats wordt gehouden door 1 klein plastic stukje aan elke kant van het slot.



Open de voering en draai de 2 schroeven onderaan de achterkant van het slot los.



Draai de 2 schroeven los die nu toegankelijk zijn.

4



Verwijder het handvat/slotblok door het naar beneden te trekken.

5



Installeer de nieuwe hendel/slot.

6



Zorg ervoor dat u hem dicht tegen de schaal vergrendelt.

7



Plaats alle schroeven terug op hun plaats + de 2 kleine clips die de voering vasthouden.

8



Sluit ten slotte de voering en vervolgens de ritssluiting van de koffer.

VERVANGING VAN HET EXTERNE TROLLEYSYSTEEM - 5 MINUTEN

BENODIGD GEREEDSCHAP

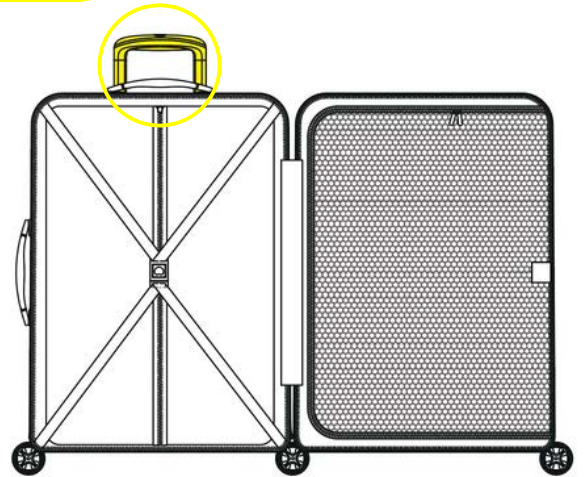

Pas het Trolley-systeem aan tot de eerste inkeping, om het uittrekken gemakkelijker te maken.



Open je koffer helemaal en vouw hem dubbel op de grond, zorg ervoor dat beide compartimenten plat zijn...

...voor gemakkelijke toegang tot de voering.

DELSEY PARIS

1946

3



Verwijder de bovenste schroeven

4



Verwijder de onderste schroeven.

5



Bewaar alle originele schroeven en onderdelen.

6



Verwijder het onderdeel van buitenaf en monteer het nieuwe onderdeel in de tegenovergestelde richting (van binnenuit) opnieuw.

7



Sluit ten slotte de voering en vervolgens de ritssluiting van de koffer.

VERVANGING VAN DE GEÏNTEGREERDE TROLLEY-SYSTEEM - 7 MINUTEN

BENODIGD GEREEDSCHAP



1

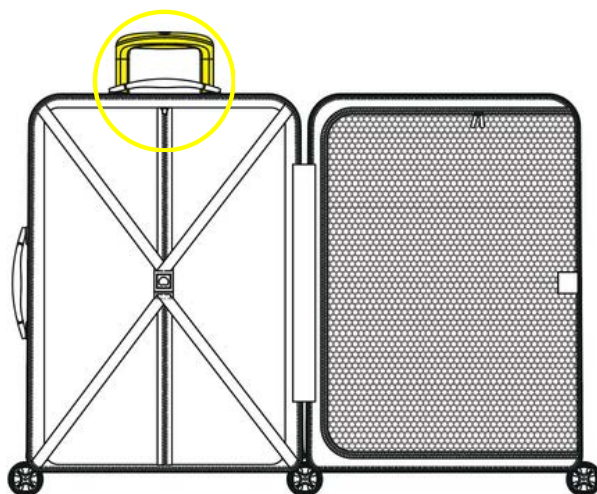

Open uw koffer volledig en vouw hem dubbel, zorg ervoor dat de twee compartimenten plat zijn, zodat u gemakkelijk bij de voering kunt.

2



Draai de bovenste en onderste schroeven los waarmee het trolleysysteem vastzit.

3



Installeer het nieuwe trolleysysteem door het vast te zetten met het multiplex en de verwijderde schroeven.

4



Sluit tot slot de voering en vervolgens uw bagage.

VERVANGING VAN EEN HANDVAT 4 MINUTEN

BENODIGD GEREEDSCHAP

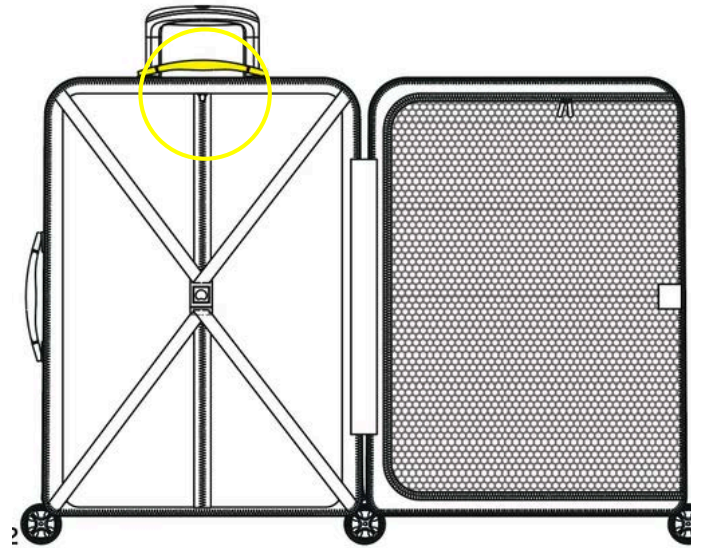
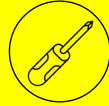

Voorbeeld van een vaste handgreep

1



Open uw koffer volledig en vouw hem dubbel op de vloer, waarbij u ervoor zorgt dat beide zijden plat liggen.

...voor gemakkelijke toegang tot de voering.

2



Draai de schroeven los waarmee de handgreep vastzit (de schroefkop is mogelijk verborgen door beschermtape).

3



Verwijder de handgreep van buitenaf en bevestig het nieuwe onderdeel erin de tegenovergestelde richting (van binnenuit). Plaats vervolgens alle schroeven weer op zijn plaats door vast te draaien.

4



Sluit ten slotte de voering en vervolgens de rits van de koffer.

VERVANGING VAN EEN TREKKER - 7 MINUTEN

BENODIGD GEREEDSCHAP



1

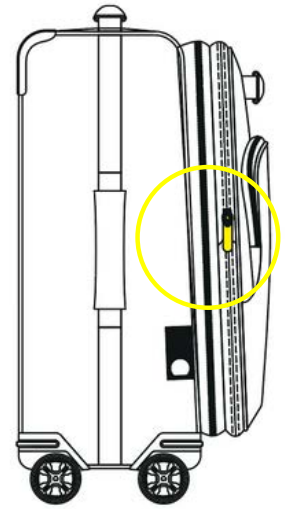

Knip de beschadigde rits door met een draadknipper of -mappen en zorg ervoor dat u de schuifbrug niet beschadigt.

2



Til de schuifbrug voorzichtig 1 of 2 mm op met een platte schroevendraaier, zodat de nieuwe ritsstrekker kan worden aangebracht.

3



Controleer de richting van het onderdeel vóór de hand: rechts of links. Sluit de schuifbrug met een tang (bescherm de tanden van de tang met dikke tape om krassen op de brug te voorkomen).

VERVANGING VAN BATTERIJEN OP EEN OVERGEWICHTSINDICATORHENDEL - 3 MINUTEN

BENODIGD GEREEDSCHAP

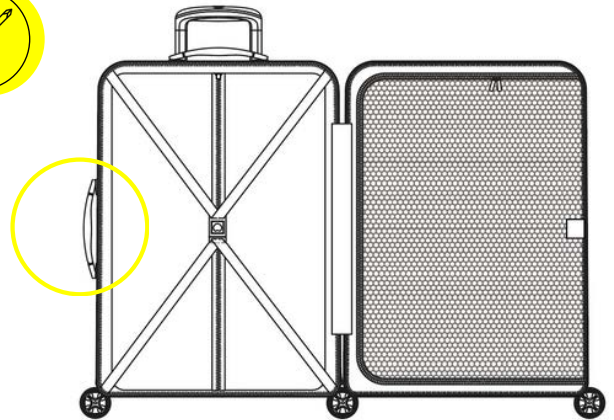

1
Open uw koffer volledig en vouw hem dubbel op de vloer, zodat de twee compartimenten plat zijn...



...voor gemakkelijke toegang tot de voering.

2



Open voorzichtig de binnenvoering om directe toegang tot het multiplex van de handgreep mogelijk te maken, en pas op dat u het materiaal of de omliggende naden niet beschadigt



Aan de achterkant van het handvat biedt een klein geïntegreerd luikje gemakkelijke toegang tot het batterijcompartiment.



Open voorzichtig dit kleine luikje aan de achterkant van het handvat en vervang de twee gebruikte knoopbatterijen door nieuwe. Zorg ervoor dat u de aangegeven polariteit (+/-) respecteert.



Sluit ten slotte de klep van het kleine luikje, u hoort een "klik". Sluit de voering en vervolgens de ritssluiting van de koffer.

Resumen

Haga clic en el tipo de reparación que desea realizar:

1. REEMPLAZO DE UNA RUEDA
2. REEMPLAZO DE UNA CERRADURA DE COMBINACIÓN
3. REEMPLAZO DE UNA CERRADURA DE COMBINACIÓN CASO MONCEY
4. SUSTITUCIÓN DEL SISTEMA TROLLEY EXTERNO
5. SUSTITUCIÓN DEL SISTEMA TROLLEY INTEGRADO SISTEMA DE CARRO
6. SUSTITUCIÓN DE UNA ASA
7. SUSTITUCIÓN DE UN CURSOR DE CREMALLERA
8. REEMPLAZO DE PILAS EN UN MANGO CON INDICADOR DE SOBREPESO

Herramientas necesarias

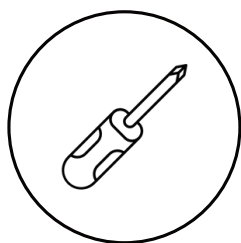

Destornillador de estrella



Alicates de corte

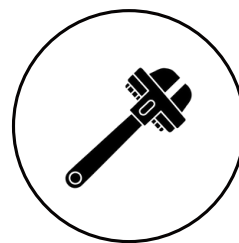

Alicates de presión



Trapo

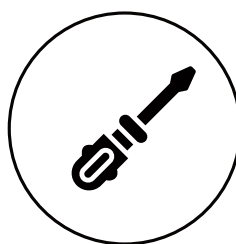

Destornillador plano

AVISO LEGAL

DELSEY PARIS no asume ninguna responsabilidad por lesiones o daños derivados de este kit de reparación de bricolaje o de estas instrucciones, por lo que le rogamos que proceda con precaución. Si tiene alguna duda sobre estas instrucciones, siempre puede ponerse en contacto con el servicio de atención al cliente en cualquier fase del proceso de reparación y le ayudaremos a resolverla.

REEMPLAZO DE UNA RUEDA 4 MINUTOS

HERRAMIENTAS NECESARIAS

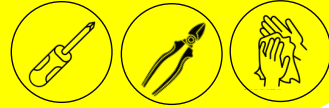

Ejemplo de rueda montada

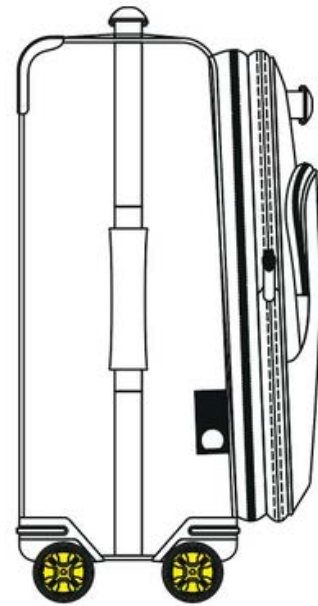

1



Abra su maleta completamente y desdóblela por la mitad en el suelo, asegurándose de que los dos compartimentos queden planos...



... para permitir un fácil acceso al forro.

2



Luego retire los tornillos de sujeción de la rueda.

3



Retire la rueda y coloque la pieza nueva en la dirección opuesta (desde el interior) y apriete todos los tornillos nuevamente en su lugar.

4



Por último, cierre el forro y el equipaje.

REEMPLAZO DE UNA CERRADURA DE COMBINACIÓN - 3 MINUTOS

HERRAMIENTAS NECESARIAS

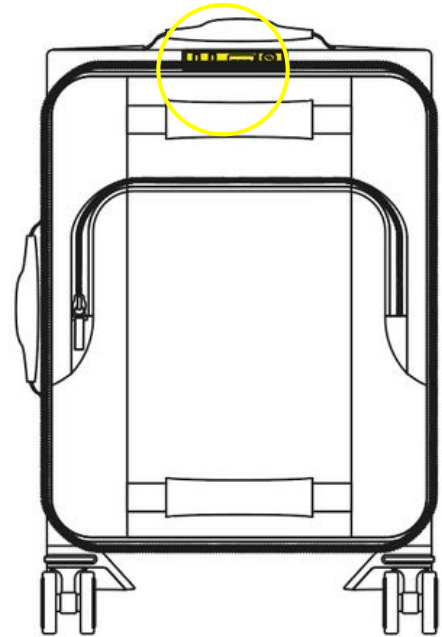
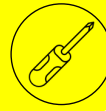

Ejemplo de cerradura montada...

1



Abra su maleta completamente y desdóblela por la mitad en el suelo, asegurándose de que los dos compartimentos queden planos.

...para permitir un fácil acceso al forro.

2



Acceda a la contraplaca de sujeción bajo el forro (las cabezas de los tornillos deben protegerse bajo una cinta para evitar el riesgo de que se salgan).



Retire los tornillos de la contraplaca.

3



Retire la cerradura dañada. Una vez retirada la cerradura, fije la nueva cerradura atornillando los tornillos en el sentido contrario a la extracción (desde el interior). Vuelva a colocar la contraplaca (desatornillada en el punto 2).

4



Y por último cierre el forro y el equipaje.

REEMPLAZO DE UNA CERRADURA DE COMBINACIÓN CASO MONCEY - 10 MINUTOS

HERRAMIENTAS NECESARIAS

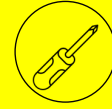

Abra su maleta completamente y desdóblela por la mitad en el suelo, asegurándose de que los dos compartimentos queden planos.



Suelte el revestimiento que se sujeta con 1 pequeña pieza de plástico a cada lado de la cerradura.



Abra el forro, desatornille los 2 tornillos que se encuentran debajo en la parte posterior de la cerradura.



Desatornille los 2 tornillos que ahora son accesibles.

4



Retire el asa/cerradura tirando hacia abajo.

5



Instale la nueva asa/cerradura.

6



Asegúrese de de bloquearlo hacia la parte superior contra la carcasa

7



Vuelva a colocar todos los tornillos en su lugar + los 2 clips pequeños que sujetan el forro.

8



Por último, cierre la cremallera del forro y posteriormente la maleta.

SUSTITUCIÓN DEL SISTEMA TROLLEY EXTERNO - 5 MINUTOS

HERRAMIENTAS NECESARIAS

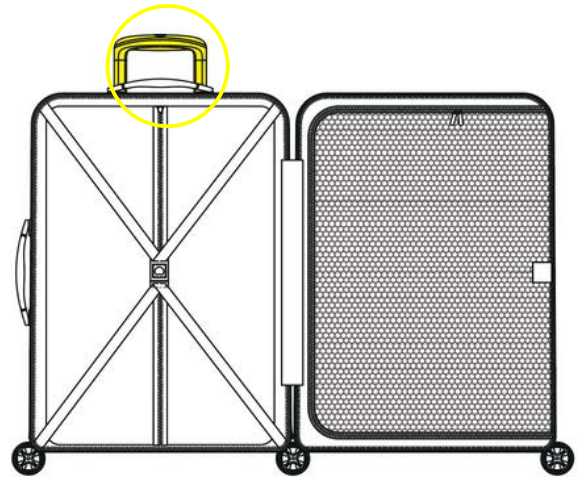

Ajustar el sistema trolley al primer nivel, para facilitar su extracción.



Abra su maleta completamente y desdóblela por la mitad en el suelo, asegurándose de que los dos compartimentos queden planos...

... para un fácil acceso al forro.

3



Retire los tornillos superiores

4



Retire los tornillos inferiores

5



Conserve todos los tornillos y piezas originales.

6



Retire la pieza del exterior y vuelva a montar la pieza nueva en la dirección opuesta (desde el interior).

7



Por último, cierre el forro y a continuación la cremallera de la maleta.

SUSTITUCIÓN DEL SISTEMA TROLLEY INTEGRADO SISTEMA DE CARRO - 7 MINUTOS

HERRAMIENTAS NECESARIAS

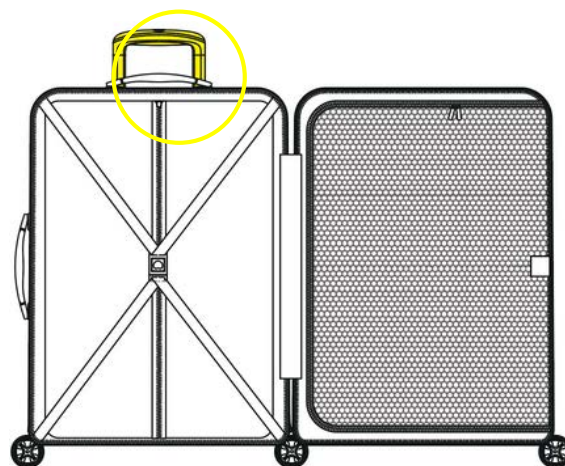

Abra su maleta completamente y desdóblela por la mitad en el suelo, asegurándose de que los dos compartimentos queden planos para acceder fácilmente al forro.



Desatornille los tornillos superior e inferior que sujetan el sistema del trolley.

DELSEY PARIS

1946

3



Instale el nuevo sistema trolley asegurándolo con la contraplaca y con los tornillos retirados.

4



Para terminar cierre el forro y a continuación su equipaje.

SUSTITUCIÓN DE UNA ASA - 4 MINUTOS

HERRAMIENTAS NECESARIAS

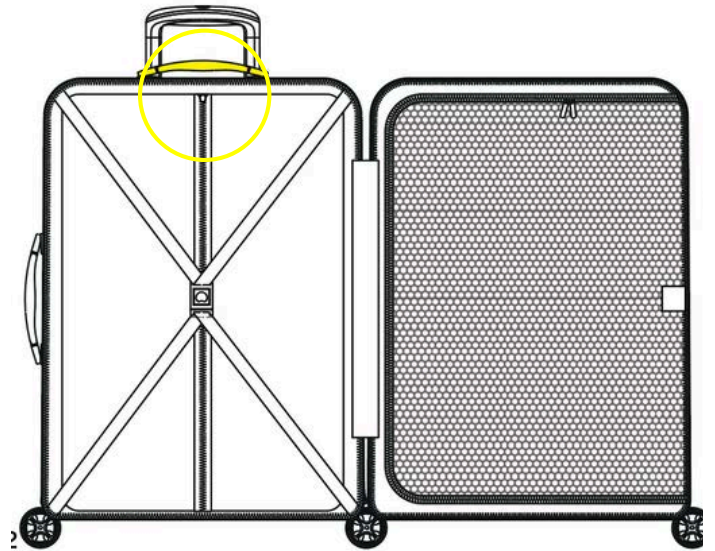
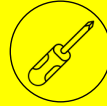

Ejemplo de asa fija

1



Abra su maleta completamente y desdóblela por la mitad en el suelo, asegurándose de que los dos compartimentos queden planos...

...para un fácil acceso al forro.

2



Desatornille los tornillos que sujetan el asa (la cabeza del tornillo posiblemente esté oculta por una cinta protectora).

3



4



Retire el asa del exterior y coloque la pieza nueva en dirección opuesta (desde el interior). A continuación coloque todos los tornillos nuevamente en su lugar apretando.

Finalmente, cierra el forro y a continuación la cremallera de la maleta

SUSTITUCIÓN DE UN CURSOR DE CREMALLERA - 7 MINUTOS

HERRAMIENTAS NECESARIAS

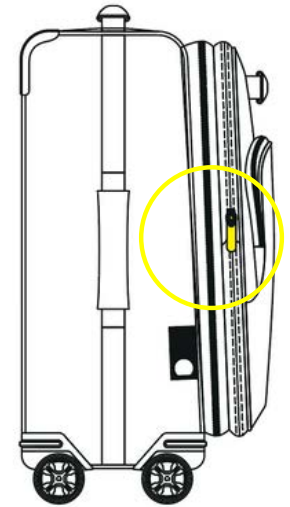
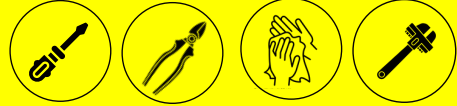

Corte la cremallera dañada con un alicate o una carpeta, vigilando no dañar el puente del cursor.



Levante suavemente el puente del cursor 1 o 2 mm con un destornillador de punta plana para poder colocar el nuevo cursor de cremallera.

3



Verifique la dirección de la pieza de antemano: derecha o izquierda. Cierre el puente del cursor con unos alicates (proteja los dientes de los alicates con cinta gruesa para no rayar el puente).

REEMPLAZO DE PILAS EN UN MANGO CON INDICADOR DE SOBREPESO - 3 MINUTOS

HERRAMIENTAS NECESARIAS

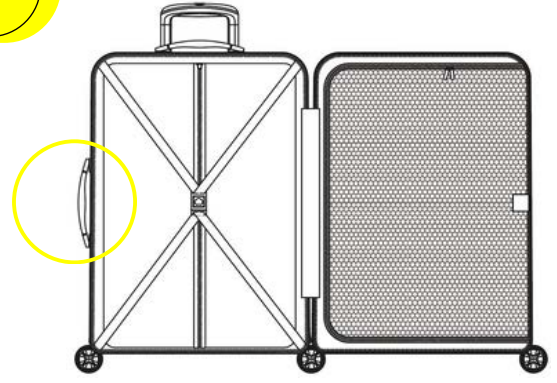

Abra su maleta completamente y desdóblela por la mitad en el suelo, asegurándose de que los dos compartimentos queden planos...



... para un fácil acceso al forro.



Abra con cuidado el forro interior para permitir el acceso directo a la contraplaca del asa y vigile no dañar el material ni las costuras circundantes.



En la parte posterior del mango, una pequeña trampa integrada proporciona un fácil acceso al compartimento de las pilas.



Abra con cuidado esta pequeña trampa ubicada en la parte posterior del asa y reemplace las dos pilas de botón usadas por otras nuevas, asegurándose de respetar la polaridad indicada (+/-).



Finalmente, cierre la tapa de la pequeña trampa, debería escuchar un "clic". Cierre el forro y a continuación la cremallera de la maleta.

NOTAS

RESUMO

Clique no tipo de reparo que deseja fazer:

1. SUBSTITUIÇÃO DE UMA RODA GIRATORIA
2. SUBSTITUIÇÃO DE UMA FECHADURA COMBINADA
3. SUBSTITUIÇÃO DE UMA FECHADURA COMBINADA CASO MONCEY
4. SUBSTITUIÇÃO DO SISTEMA DE CARRINHO EXTERNO
5. SUBSTITUIÇÃO DO SISTEMA DE CARRINHO INTEGRADO
6. SUBSTITUIÇÃO DE UMA ALÇA
7. SUBSTITUIÇÃO DE UM PUXADOR DESLIZANTE
8. SUBSTITUIÇÃO DE BATERIAS NUM PUNHO INDICADOR DE SOBREPESO

LÉXICO

Ferramentas Necessárias

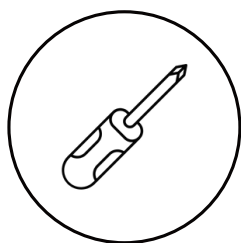

Chave de fenda cruciforme



Alicate de corte

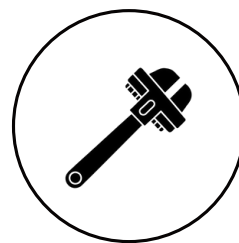

Alicate de extensão



Pano



Chave de fenda plana

AVISO LEGAL

A DELSEY PARIS não se responsabiliza por ferimentos ou danos resultantes deste kit de reparação DIY ou destas instruções, pelo que deve proceder com cautela. Se tiver alguma dúvida sobre estas instruções, pode sempre contactar o serviço de apoio ao cliente em qualquer fase do processo de reparação e nós ajudamo-lo!

SUBSTITUIÇÃO DE UMA RODA GIRATORIA 4 MINUTOS

FERRAMENTAS NECESSÁRIAS



Exemplo de montagem de roda

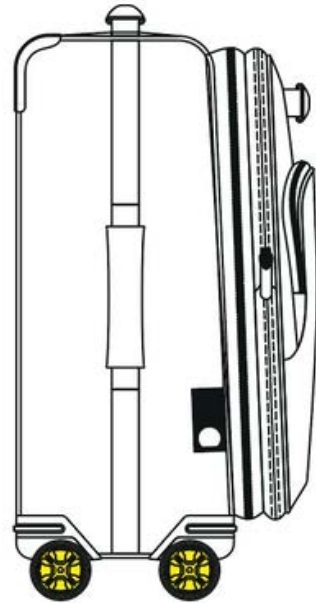

1



Por favor, abra totalmente a sua mala e desdobre-a ao meio no chão, garantindo que os dois compartimentos estejam planos...



... para permitir um acesso fácil ao forro.

DELSEY PARIS

1 9 4 6

2



Em seguida, remova o(s) parafuso(s) de retenção da roda

3



Remova a roda e coloque a nova peça na direção oposta (por dentro) e aperte todos os parafusos de volta no lugar.

4



Por fim, feche o forro e a bagagem.

SUBSTITUIÇÃO DE UMA FECHADURA COMBINADA - 3 MINUTOS

FERRAMENTAS NECESSÁRIAS

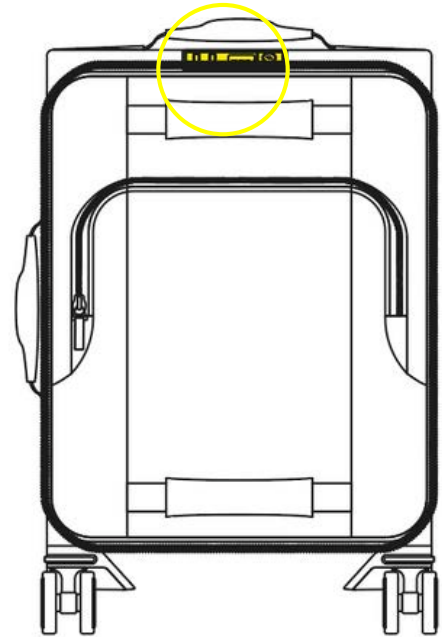
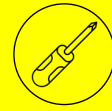

Exemplo de montagem de fechadura...

1



Abra totalmente a sua mala e desdobre-a ao meio no chão, garantindo que os dois compartimentos estejam planos.

...para permitir um acesso fácil ao revestimento.

2



Acesse o compensado do fixador sob o liner (as cabeças dos parafusos devem ser protegidas por fita para evitar o risco de desalojamento).



Remova os parafusos da madeira compensada.

3



Remova a fechadura danificada. Depois de remover a fechadura, fixe a nova fechadura apertando os parafusos na direção oposta à extração (por dentro). reposicione a contraplaca (desparafusada no ponto 2).

4



E por fim feche o forro e a bagagem.

SUBSTITUIÇÃO DE UMA FECHADURA COMBINADA CASO MONCEY - 10 MINUTOS

FERRAMENTAS NECESSÁRIAS

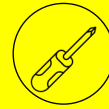

1



Abra completamente a sua mala e desdobre-a ao meio no chão, certificando-se de que os dois compartimentos estão planos...



Solte o revestimento que é preso por um pequeno pedaço de plástico em cada lado da fechadura.

2



Abra o revestimento, desparafuse os 2 parafusos abaixo na parte traseira da trava.

3



Desparafuse os 2 parafusos que agora estão acessíveis

4



Remova a alça/bloco de trava puxando para baixo.

5



Instale a nova alça/trava.

6



Certifique-se de travá-lo bem alto contra a casca

7



Coloque todos os parafusos de volta no lugar + os 2 pequenos cliques que prendem o forro

8



Por fim, feche o forro e depois o zíper da mala.

SUBSTITUIÇÃO DO SISTEMA DE CARRINHO EXTERNO - 5 MINUTOS

FERRAMENTAS NECESSÁRIAS

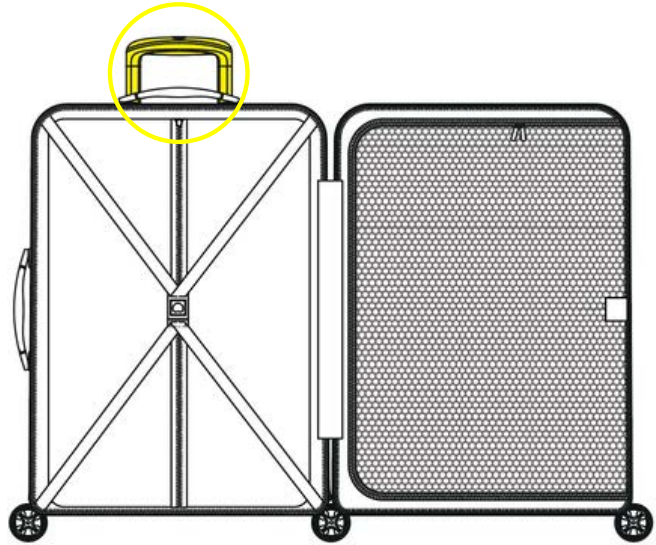
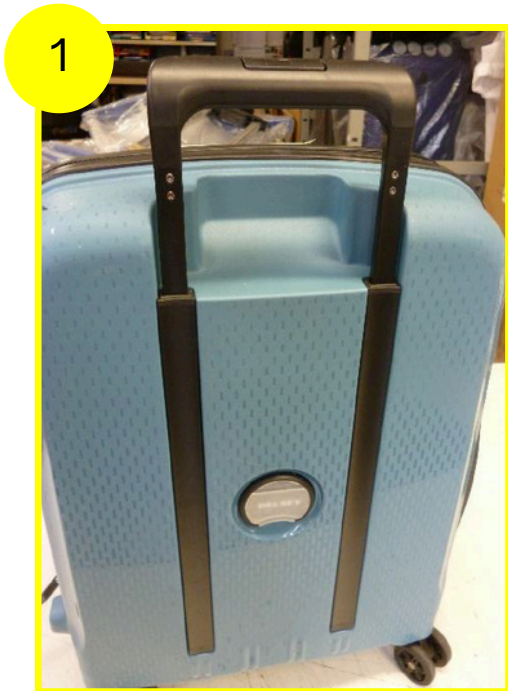
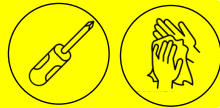

Ajuste o sistema Trolley para o primeiro entalhe, para facilitar a extração.



Abra completamente a sua mala e desdobre-a ao meio no chão, certificando-se de que ambos os compartimentos estão planos ...

... para um acesso fácil ao forro.

DELSEY PARIS

1 9 4 6

3



Remova os parafusos superiores

4



Remova os parafusos inferiores.

5



Guarde todos os parafusos e peças originais.

6



Retire a peça por fora e monte novamente a nova peça no sentido oposto (por dentro).

7



Por fim, feche o forro e depois o zíper da mala.

SUBSTITUIÇÃO DO SISTEMA DE CARRINHO INTEGRADO - 7 MINUTOS

FERRAMENTAS NECESSÁRIAS



1

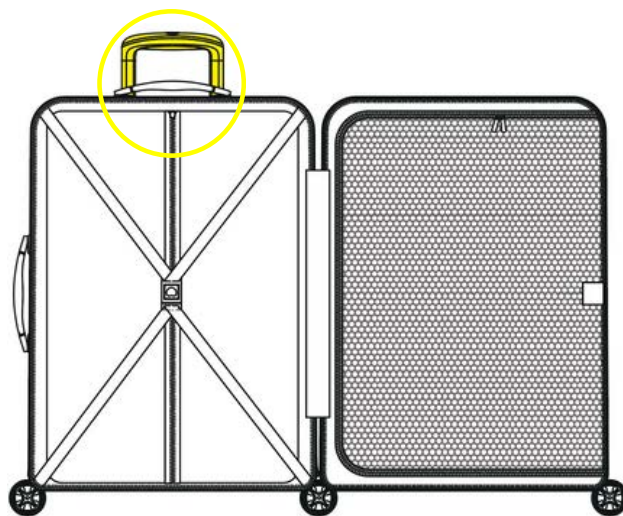

Abra completamente a sua mala e desdobre-a ao meio, certificando-se de que os dois compartimentos estão planos, para facilitar o acesso ao forro.

2



Desaparafuse os parafusos superiores e inferiores que prendem o sistema do carrinho.

DELSEY PARIS

1 9 4 6

3



Instale o novo sistema de carrinho fixando-o com madeira compensada e os parafusos removidos.

4



Para finalizar feche o forro e depois a sua bagagem.

SUBSTITUIÇÃO DE UMA ALÇA 4 MINUTOS

FERRAMENTAS NECESSÁRIAS

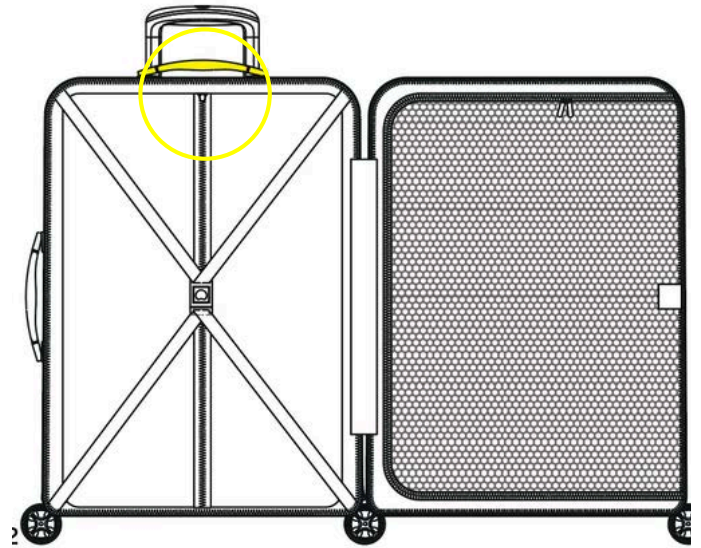

Exemplo de alça fixa

1



Abra completamente a mala e desdobre-a ao meio no chão, garantindo que ambos os lados fiquem planos.

...para facilitar o acesso ao forro.

2



Desaparafuse os parafusos que prendem a alça (cabeça do parafuso possivelmente escondida por fita protetora).

3



4



Remova a alça do lado de fora e fixe a nova peça na direção oposta (por dentro). Depois coloque todos os parafusos de volta no lugar apertando.

Por fim, feche o forro e depois o zíper da mala.

SUBSTITUIÇÃO DE UM PUXADOR DESLIZANTE - 7 MINUTOS

FERRAMENTAS NECESSÁRIAS



1

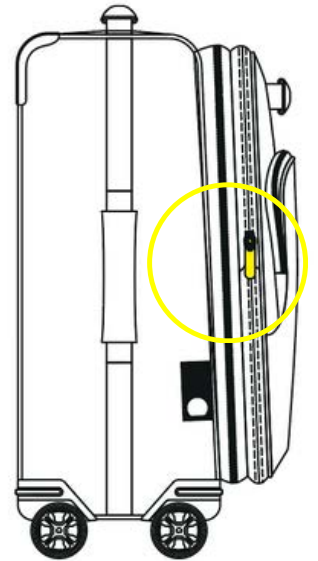

Corte o zíper danificado com um alicate, tomando cuidado para não danificar a ponte deslizante.

2



Levante suavemente a ponte deslizante 1 ou 2 mm com uma chave de fenda para que o novo extrator de zíper possa ser encaixado.

3



Verifique a direção da peça com antecedência: direita ou esquerda. Feche a ponte deslizante com um alicate (proteja os dentes do alicate com fita grossa para não riscar a ponte).

SUBSTITUIÇÃO DE BATERIAS NUM PUNHO INDICADOR DE SOBREPESO- 3 MINUTOS

FERRAMENTAS NECESSÁRIAS

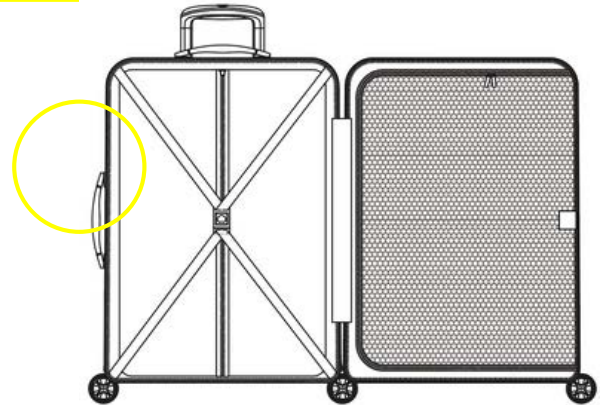

Abra completamente a sua mala e desdobre-a ao meio no chão, certificando-se de que os dois compartimentos ficam planos...



... para um acesso fácil ao forro.

2



Abra cuidadosamente o forro interno para permitir acesso direto ao compensado do cabo e tome cuidado para não danificar o material ou as costuras ao redor



Na parte de trás da alça, uma pequena escotilha integrada proporciona acesso fácil ao compartimento das baterias.



Abra com cuidado esta pequena portinhola localizada na parte traseira da alça e substitua as duas pilhas tipo botão usadas por novas, respeitando a polaridade indicada (+/-).



Por fim, feche a aba da pequena escotilha, você deverá ouvir um “clique”. Feche o forro e depois o zíper da mala.

風

舞

舞

舞

目次

修理したい 種類をクリックしてください

1. キャスター車輪の交換
2. コンビネーションロックの交換
3. ダイヤル錠の交換
例・モンシー
4. トロリーシステムを最初の位置に調整し、取り出しやすくしてください。
5. 統合トロリーシステムの交換
6. ハンドルの交換
7. スライダープルの交換
8. 過重量インジケータのハンドルのバッテリー交換

レキシコン

必要な工具

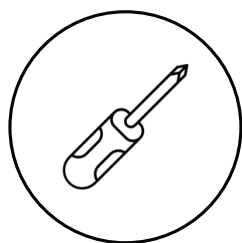

プラスドライバー



切断用ペンチ

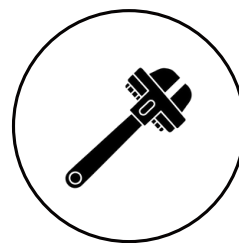

切断用プライヤー



ぞうきん

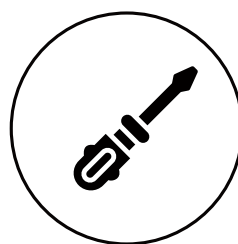

マイナスドライバー

免責事項

DELSEY PARISは、このDIY修理キットや説明書に起因する怪我や損害について責任を負いません。この説明書についてご不明な点がございましたら、修理のどの段階でも、いつでもカスタマーサービスにご連絡ください!

キャスター車輪の交換 4分

必要な工具

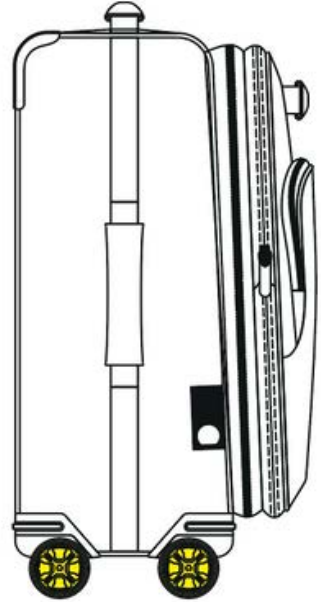

車輪の組み立ての例



1
スーツケースを完全に開き、床に半分
分に広げ、
両方のコンパートメントが平らにな
るようにします。

... ライニングへの簡単なアクセス
を可能にするためです。

2



次に、ホイールから固定ネジを取り外します。

3



車輪を取り外し、新しい部品を逆方向（内側から）で取り付け、すべてのネジを元の位置にしっかりと締めてください。」

4



最後に裏地と荷物を閉じます。

コンビネーションロックの交換 3分

必要な工具

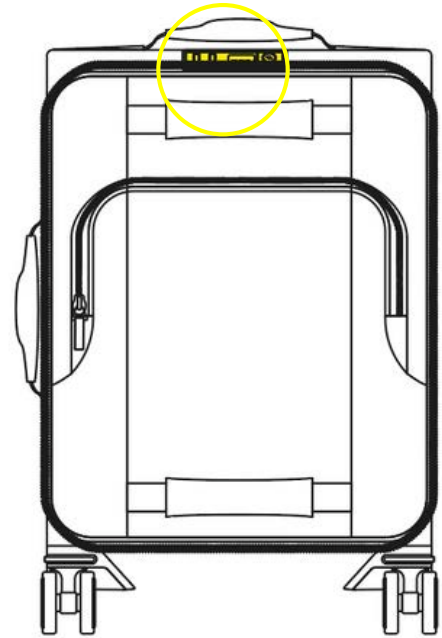

ロックアセンブリの例...

1



スーツケースを完全に開き、床の上で半分に広げ、2つのコンパートメントが平らになるようにします。



...裏地に簡単にアクセスできるようにします

2



ライナーの下にあるファスナーの合板にアクセスします (外れる危険を避けるために、ネジの頭をテープで保護する必要してください)。



合板からネジを外します。

3



損傷した鍵を取り外してください。鍵が取り外されたら、新しい鍵を取り付けます。ネジは取り外しとは反対の方向に回して締めます (内側から)。カウンタープレート (ポイント2で取り外したもの) を戻してください。

4



最後に裏地と荷物を閉じます。

ダイヤル錠の交換 例・モンシー - 10分

必要な工具



1



スーツケースを完全に開き、床の上で半分に広げ、2つのコンパートメントが平らになるようにします。



ロックの両側にある小さなプラスチック部品で固定されているライナーのクリップを外してください

2



ライナーを開き、ロックの裏側にある下の2本のネジを外します。

3



今アクセス可能な2つのネジを外してください

4



ハンドル/ロックブロックを下に引いて取り外します。

5



新しいハンドル/ロックを取り付けます。

6



必ずシェルの高い位置でロックしてください

7



すべてのネジを元の位置に戻し、ライニングを保持している2つの小さなクリップを取り付けます

8



最後にスーツケースの裏地を閉め、ジッパーを閉めます。

トロリーシステムを最初の位置に調整し、
取り出しやすくしてください。 - 5分

必要な工具

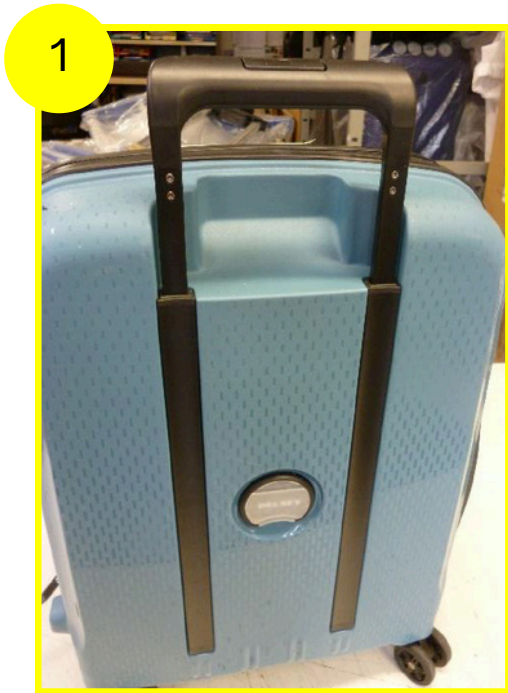
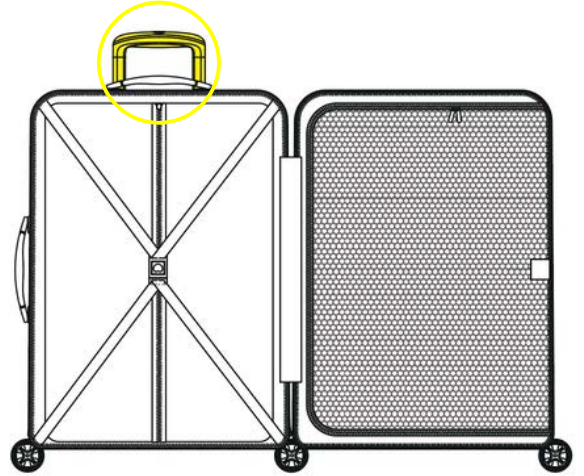

取り出しやすくするために、トロリーシステムを最初のノッチに調整します。



スーツケースを完全に開き、床の上で半分に広げ、両方のコンパートメントが平らであることを確認します。



ライニングに簡単にアクセスできるように

3



上部のネジを取り外します

4



底部のネジを取り外します。

5



元のネジと部品はすべて保管してください。

6



外側から部品を取り外し、新しい部品を逆の方向（内側から）に再度組み立ててください。

7



最後にスーツケースの裏地を閉め、ジッパーを閉めます

統合トロリーシステムの交換 - 7分

必要な工具

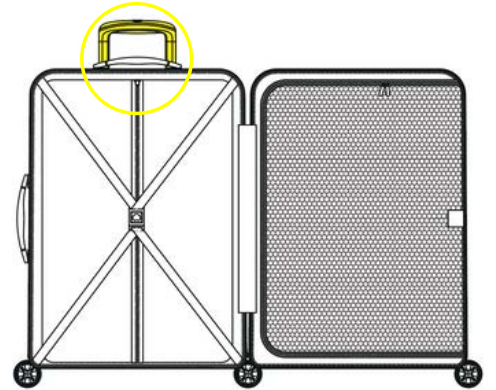
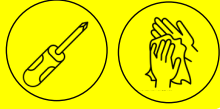

1



スーツケースを完全に開き、半分に広げて、裏地に簡単にアクセスできるように、2つのコンパートメントが平らになるようにします。

2



トロリーシステムを固定している上下のネジを外します。

3



新しいトロリーシステムを取り付け、
合板と取り外したネジで
してください。

4



最後に裏地を閉めてから荷物を入れます。

ハンドルの交換 4分

必要な工具



例：固定ハンドル

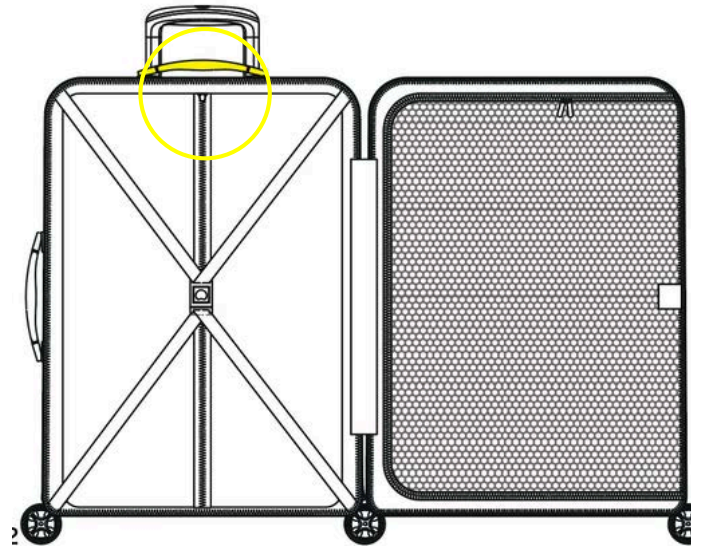

1



スーツケースを完全に開き、半分に広げて、裏地に簡単にアクセスできるように、2つのコンパートメントが平らになるようにします。



ライニングに簡単にアクセスできるように

2



ハンドルを固定しているネジを外してください（ネジの頭が保護テープで隠れている可能性があります）

3



外側からハンドルを取り外し、新しい部品を取り付けてください
反対方向（内側から）。次に、すべてのネジを取り付けます
締めて元の位置に戻します。

4



最後に裏地を閉め、スーツケースのジッパーを閉めます。

スライダープルの交換 - 7分

必要な工具

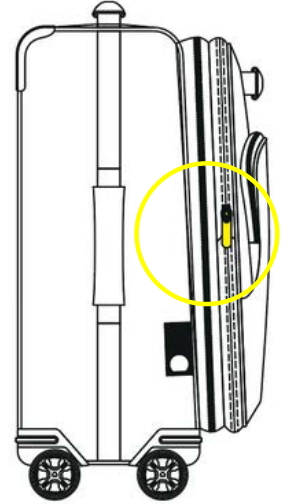

1



スライダーブリッジを傷つけないように注意しながら、損傷したジッパーをカッターまたはフォルダーで切ります。

2



マイナスドライバーを使用してスライダーブリッジを1~2mm ゆっくりと持ち上げ、新しいジッパープラーを取り付けられるようにします。

3



事前に部品の位置を確認してください。ペンチを使用してスライダーブリッジを閉じます (ブリッジを傷つけないように、ペンチの歯を厚いテープで保護します)。

過重量インジケータのハンドルのバッテリー交換 - 3分

必要な工具

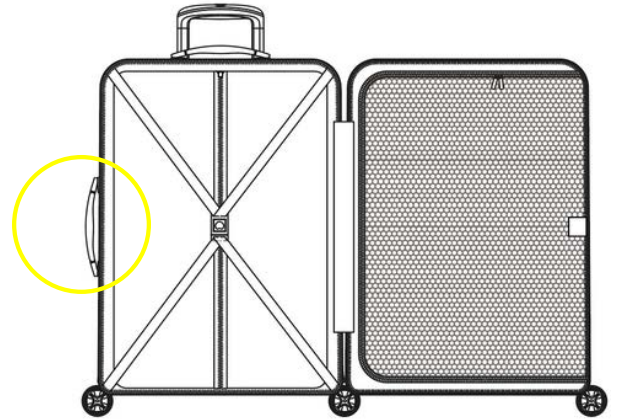

スーツケースを完全に開き、床の上で半分に広げて、2つのコンパートメントが平らになるようにします。



...裏地に簡単にアクセスできます。



内側のライニングを慎重に開き、ハンドル合板に直接アクセスできるようにし、素材や周囲の縫い目を傷つけないように注意してください。



ハンドルの裏側には小さな統合されたハッチがあり、バッテリーコンパートメントに簡単にアクセスできます



ハンドルの後ろにあるこの小さなハッチを慎重に開き、表示されている(+/-)を確認をし、2電池を新しいものと交換します。



最後に、小さなハッチのフラップを閉じると、「カチッ」という音が聞こえます。スーツケースの裏地を閉めてからジッパーを閉めます。

콘텐츠

수행하려는 수리 유형을 클릭하십시오.

1. 캐스터 휠 교체
2. 콤비네이션 자물쇠 교체
3. 콤비네이션 자물쇠 교체
케이스 몬시
4. 외부 트롤리 시스템 교체
5. 통합 교체
트롤리 시스템
6. 핸들 교체
7. 슬라이더 풀 교체
8. 중량 초과 측정 핸들의 배터리 교체

사전

필수 도구

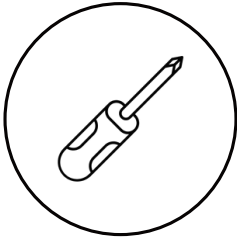

십자형 드라이버



펜치



파이프 렌치



수건

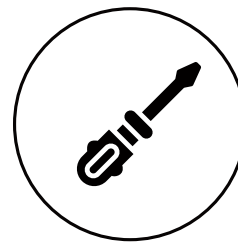

일자형 드라이버

면책 조항

델세이파리는 이 DIY 수리 키트 또는 이 설명서로 인한 부상이나 손해에 대해 책임을 지지 않으므로 주의하여 진행하시기 바랍니다. 이 지침에 대해 궁금한 점이 있으면 수리 과정의 어느 단계에서든 고객 서비스에 연락하시면 도움 118을 드릴 수 있습니다!

캐스터 휠 교체 4분

필수 도구

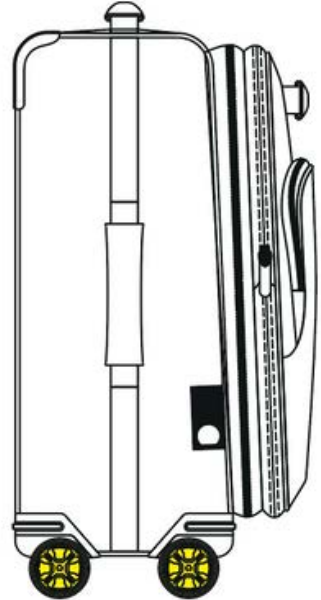

바퀴 조립 예시



여행 가방을 완전히 열고 바닥에 반으로 펼쳐서 두 개의 수납공간이 평평하게 되도록 해주세요.

... 안감에 쉽게 접근할 수 있도록 합니다.

DELSEY PARIS

1946

2



그런 다음 바퀴 고정 나사를 제거합니다.

3



바퀴를 제거하고 새 부품을 역순으로(내부)으로 부착한 후 모든 나사를 원래 위치로 조여주세요.

4



마지막으로 안감과 여행 가방을 닫으세요.

콤비네이션 자물쇠 교체 3분

필수 도구

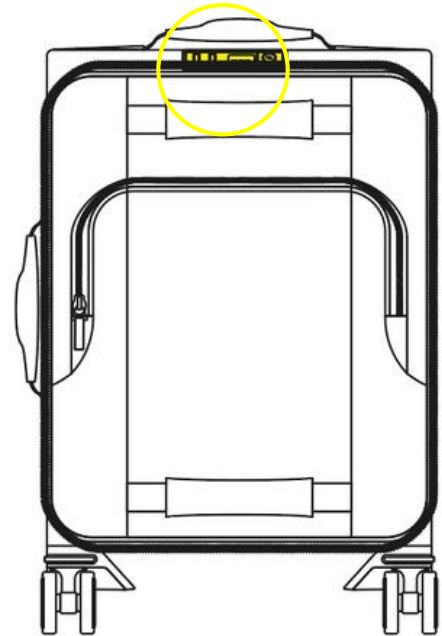

잠금 장치의 예...

1



여행 가방을 완전히 열고 바닥에 반으로 펼쳐서 두 개의 수납공간이 평평하게 되도록 해주세요.

...안감에 쉽게 접근할 수 있도록 합니다.

2



안감 안쪽 자물쇠 고정 장치 합판에 접근하세요(나사 머리가 이탈 위험을 방지하기 위해 테이프로 보호되어야 함).



합판에서 나사를 제거합니다.

3



손상된 자물쇠를 제거하세요. 자물쇠가 제거되면 새로운 자물쇠를 추출 역순(내부에서)으로 나사를 조여 고정하세요. 카운터 플레이트의 위치를 다시 조정합니다(지점 2에서 나사 풀림).

4



마지막으로 안감과 여행 가방을 닫으세요.

콤비네이션 자물쇠 교체 케이스 몬시 - 10 분

필수 도구



1



여행가방을 완전히 열고 바닥에 반으로
펴서 두 칸이 평평한지 확인하세요.



자물쇠 양쪽에 있는 작은 플라스틱 조각
1개로 고정되어 있는 라이너의 클립을
푼니다.

2



라이너를 열고 잠금 장치 뒷면 아래에
있는 나사 2개를 푸세요.

3



이제 접근 가능한 나사 2개를 푸세요.

4



아래쪽으로 당겨 핸들/잠금 블록을 제거합니다.

5



새 손잡이/잠금 장치를 설치하십시오.

6



웰에 단단히 고정하세요

7



모든 나사와 라이닝을 고정하는 2개의 작은 클립을 제자리에 다시 놓습니다.

8



마지막으로 안감을 닫은 후 여행가방의 지퍼를 닫아주세요.

외부 트롤리 시스템 교체 - 5분

필수 도구

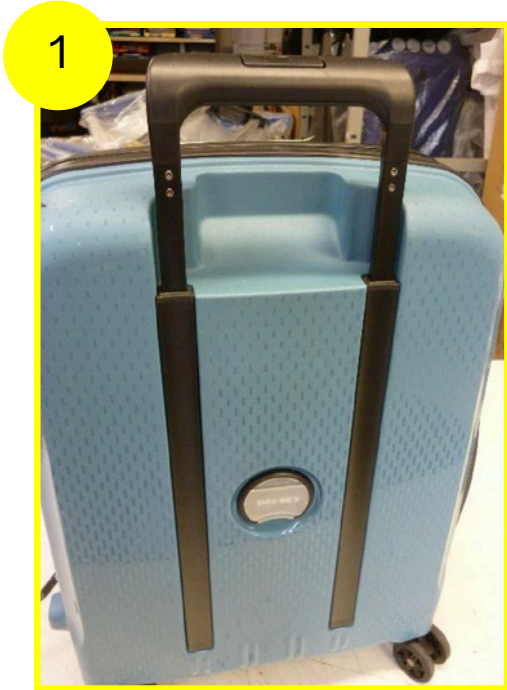
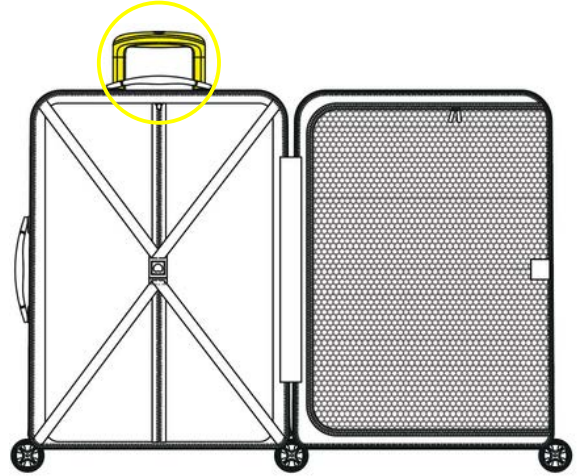
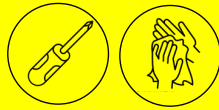

쉽게 추출할 수 있도록 트롤리 시스템을 첫 번째로 조정합니다.



여행가방을 완전히 열고 바닥에 반으로 펼쳐서 두 수납칸이 모두 평평한지 확인하세요.



... 안감에 쉽게 접근할 수 있습니다.

3



상단 나사 제거

4



하단 나사를 제거합니다.

5



모든 원래 나사와 부품을 보관하십시오.

6



외부에서 부품을 제거하고 반대 방향(내부에서)으로 새 부품을 다시 조립합니다.

7



마지막으로 안감을 닫은 후 여행가방의 지퍼를 닫아주세요.

통합 교체 트롤리 시스템 - 7분

필수 도구

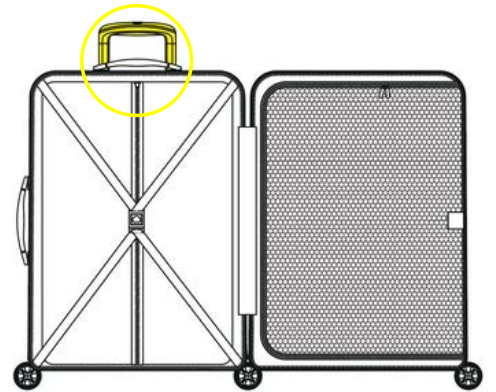
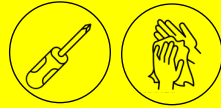

1



여행가방을 완전히 열고 반으로 펼친 후 안감에 쉽게 접근할 수 있도록 두 수납칸이 평평한지 확인하세요.

2



트롤리 시스템을 고정하는 상단 및 하단 나사를 푸십시오.

3



합판으로 고정하여 새 트롤리 시스템을
설치하고
제거된 나사.

4



마무리하려면 안감을 닫은 다음 수하물을
담으세요.

핸들 교체 4분

필수 도구



고정 핸들의 예

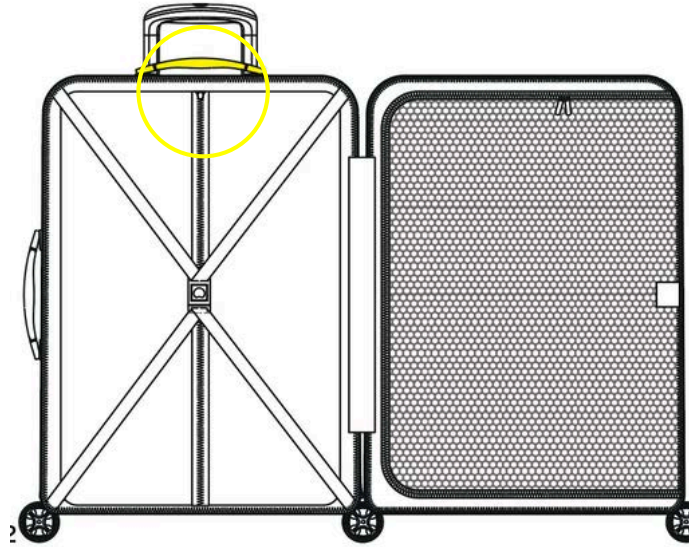

1



여행 가방을 완전히 열고 바닥에 반으로 펴서 양쪽이 편평하게 놓이도록 하세요.

...안감에 쉽게 접근할 수 있습니다.

2



핸들을 고정하고 있는 나사를 푸십시오(나사 머리는 보호 테이프로 숨겨져 있을 수 있음).

3



외부에서 손잡이를 제거하고 새 부품을 내부에 부착하십시오.

반대 방향(안쪽에서). 그런 다음 나사를 모두 끼우고 조여서 제자리로 돌아갑니다.

4



안감을 마무리한 후 여행가방을 닫으세요.

슬라이더 풀 교체 - 77분

필수 도구

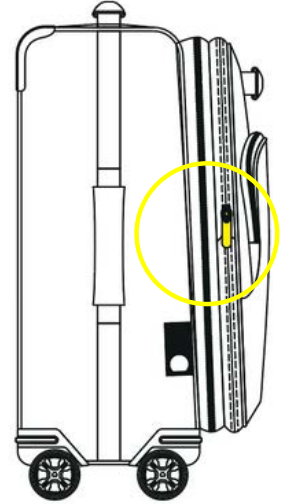
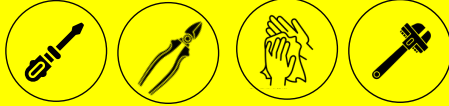

1



슬라이더 브릿지가 손상되지 않도록 주의하면서 손상된 지퍼를 와이어 커터나 풀더로 자릅니다.

2



새 지퍼 풀러가 장착될 수 있도록 일자 드라이버를 사용하여 슬라이더 브릿지를 1~2mm 정도 들어올립니다.



부품의 방향을 미리 확인하십시오: 오른쪽 또는 왼쪽. 플라이어를 사용하여 슬라이더 브릿지를 단습니다. (브릿지가 굽히지 않도록 두꺼운 테이프로 펀치의 톱니를 보호하십시오.)

중량 초과 측정 핸들의 배터리 교체 - 3 분

필수 도구

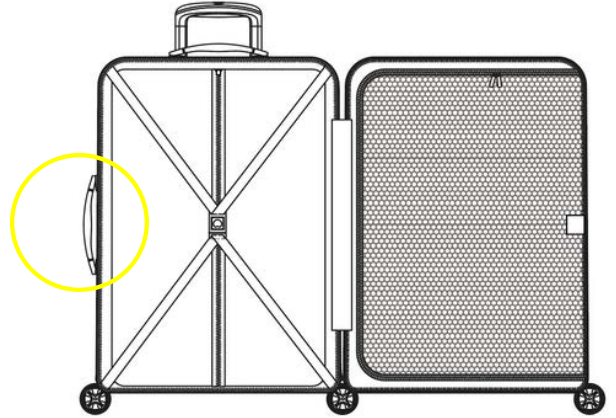
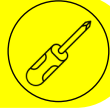

여행 가방을 완전히 열고 바닥에 반으로 펼쳐서 두 칸이 평평한지 확인하세요.



... 안감에 쉽게 접근할 수 있습니다.



내부 안감을 조심스럽게 열어 핸들 합판에 직접 접근할 수 있도록 하고, 소재나 주변 봉제선을 손상시키지 않도록 주의하세요.



핸들 뒷면에는 작은 일체형 해치가 있어 배터리 수납공간에 쉽게 접근할 수 있습니다.



핸들 뒤쪽에 있는 이 작은 해치를 조심스럽게 열고 사용한 버튼 배터리 2개를 표시된 극성(+/-)을 준수하여 새 배터리로 교체하세요.



마지막으로 작은 해치의 덮개를 닫으면 "딸깍" 소리가 들립니다. 안감을 닫은 다음 여행 가방의 지퍼를 닫습니다.

sammanfattning

Klicka på den typ av reparation du vill göra:

1. BYTE AV ETT HJUL
2. BYTE AV ETT KOMBINATIONSLÅS
3. BYTE AV ETT KOMBINATIONSLÅS
CASE MONCEY
4. BYTE AV DET EXTERNA FRAGHANDTAGS
SYSTEMET
5. BYTE AV INTEGRERAD DRAGHANTAG
VAGNSYSTEM
6. BYTE AV ETT HANDTAG
7. BYTE AV EN SLIDER DRAGARE
8. BYTE AV BATTERIER PÅ EN ÖVERVIKT
INDIKATORHANDTAG

Nödvändiga verktyg

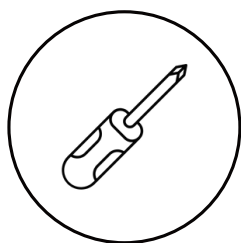

Skruvmejsel korsformad



Tång skärning

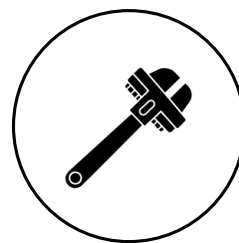

Tång grenuttag



Trasa

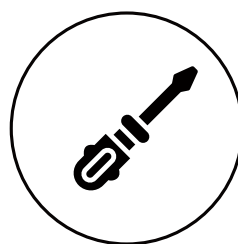

Skruvmejsel platt

ANSVARFRISKRIVNING

DELSEY PARIS tar inte ansvar för skador som uppstår till följd av denna DIY-reparations-sats eller dessa instruktioner, så fortsätt med försiktighet. Om du har några frågor om dessa instruktioner kan du alltid kontakta kundtjänst när som helst under reparationsprocessen, så hjälper vi dig igenom den! 137

BYTE AV ETT HJUL 4 MINUTER

NÖDVÄNDIGA VERKTYG



Exempel på ett hjulaggregat

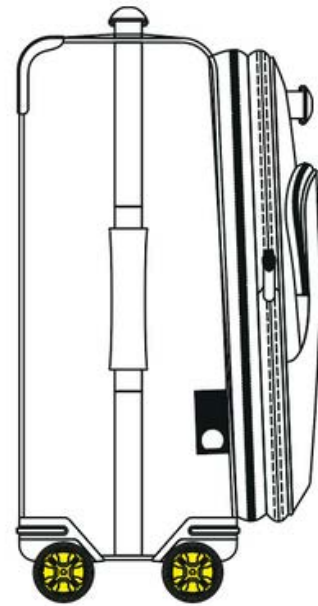

1



Vänligen öppna din resväska helt och vik ut den på mitten på golvet, se till att de två facken är platta...



... för att ge enkel åtkomst till fodret.

DELSEY PARIS

1 9 4 6

2



Ta sedan bort fästskruvarna från hjulet.

3



Ta bort hjulet och fäst den nya delen i motsatt riktning (inifrån) och dra åt alla skruvar på plats.

4



Stäng slutligen fodret och bagaget.

BYTE AV ETT KOMBINATIONSLÅS 3 MINUTER

NÖDVÄNDIGA VERKTYG



Exempel på en låsenhet...

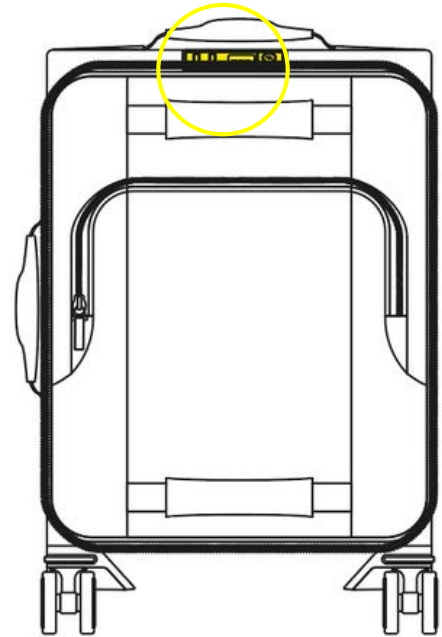

1



Öppna din resväska helt och vik ut den på mitten på golvet, se till att de två facken är plana.



...för att ge enkel åtkomst till fodret.

2



Öppna och synliggör fästelementets plywood under fodret (skruvhuvudena bör skyddas under tejp för att undvika risken att lossna).



Ta bort skruvarna från plywooden.

3



Ta bort det skadade låset. När låset har tagits bort, fixera sedan det nya låset genom att skruva skruvarna i motsatt riktning (inifrån). flytta tillbaka motplattan (avskruvad vid punkt 2).

4



Och slutligen, stäng fodret och bagaget.

BYTE AV ETT KOMBINATIONSLÅS CASE MONCEY - 10 MINUTER

NÖDVÄNDIGA VERKTYG



Öppna din resväska helt och vik ut den på mitten på golvet, se till att de två facken är plana...



Haka loss fodret som hålls på plats av 1 liten plastbit på varje sida av låset.



Öppna fodret, skruva loss de 2 skruvarna nedan på baksidan av låset.



Skruva loss de 2 skruvarna som nu är åtkomliga.

DELSEY PARIS

1946

4



Ta bort handtaget/låsblocket genom att dra nedåt.

5



Montera det nya handtaget/låset.

6



Se till att låsa den högt upp mot skalet

7



Sätt tillbaka alla skruvar på plats + de 2 små klämmorna som håller fodret.

8



Slutligen, stäng fodret och sedan dragkedjan på resväskan.

BYTE AV DET EXTERNA FRAGHANDTAGS SYSTEMET - 5 MINUTER

NÖDVÄNDIGA VERKTYG

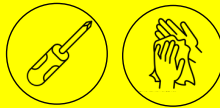

1

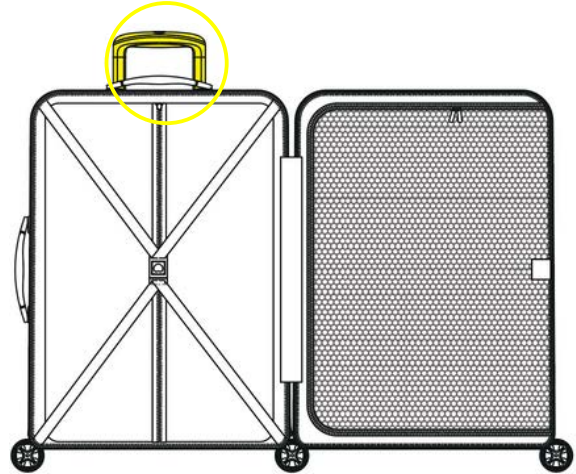

Justera vagnsystemet till första hacket för att göra det lättare att dra ut.

2



Öppna din resväska helt och vik ut den på mitten på golvet, se till att båda facken är platta ...

... för enkel åtkomst till fodret.

DELSEY PARIS

1946

3



Ta bort de övre skruvarna

4



Ta bort de nedre skruvarna.

5



Behåll alla originalsruvar och delar.

6



Ta bort delen från utsidan och sätt tillbaka den nya delen i motsatt riktning (inifrån).

7



Slutligen, stäng fodret och sedan dragkedjan på resväskan.

BYTE AV INTEGRERAD DRAGHANTAG VAGNSYSTEM - 7 MINUTER

NÖDVÄNDIGA VERKTYG



1

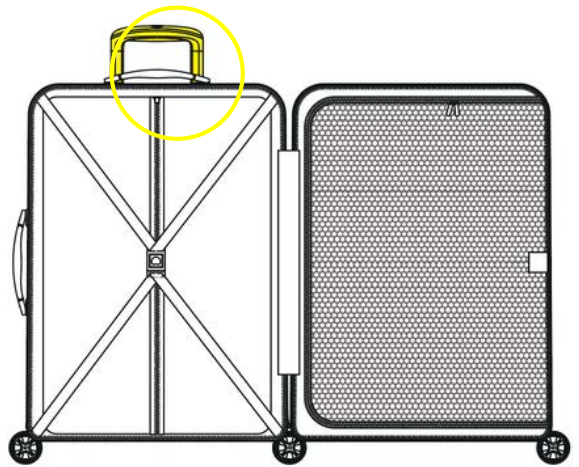

Öppna din resväska helt och vik ut den på mitten, se till att de två facken är platta, för enkel åtkomst till fodret.

2



Skruva loss de övre och nedre skruvarna som håller fast vagnsystemet.

DELSEY PARIS

1 9 4 6

3



Installera det nya vagnsystemet genom att säkra det med plywood och de borttagna skruvarna.

4



För att avsluta stäng fodret och sedan ditt bagage.

BYTE AV ETT HANDTAG - 4 MINUTER

NÖDVÄNDIGA VERKTYG

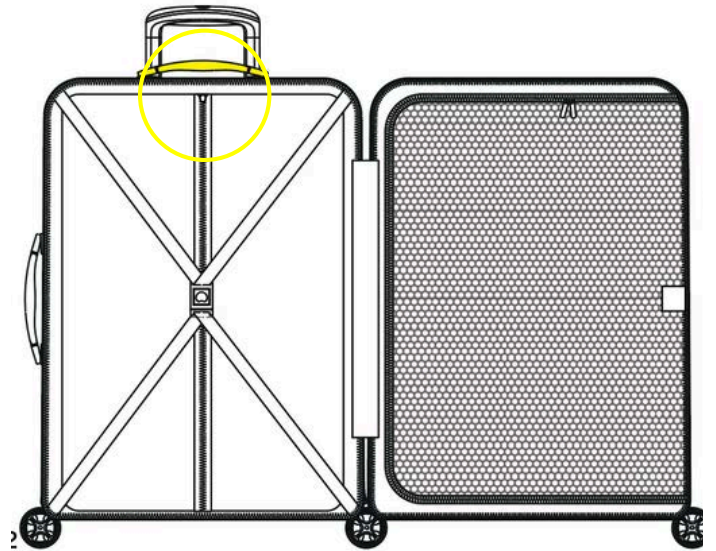

Exempel på fast handtag

1



Öppna din resväska helt och vik ut den på mitten på golvet, se till att båda sidorna ligger plant.

...för enkel åtkomst till fodret.

DELSEY PARIS

1946

2



Skruva loss skruvarna som håller handtaget (skruvhuvudet eventuellt dold av skyddstejp).

3



Ta bort handtaget från utsidan och fäst den nya delen i motsatt riktning (inifrån). Sätt sedan i alla skruvar tillbaka på plats genom att dra åt.

4



Slutligen, stäng fodret och sedan dragkedjan för resväskan.

BYTE AV EN SLIDER DRAGARE 7 MINUTER

NÖDVÄNDIGA VERKTYG



1

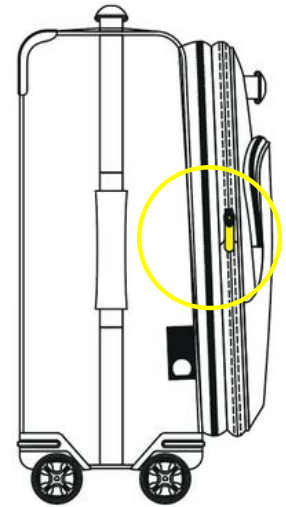

Klipp av den skadade dragkedjan med trådkärare eller foldrar, var noga med att inte skada glidbryggan.

2



Lyft försiktigt glidbryggan 1 eller 2 mm med en platt skruvmejsel så att den nya blixtlåsavdragaren kan monteras.

3



Kontrollera riktningen på delens riktning innan hand: höger eller vänster. Stäng skjutbryggan med en tång (skydda tänderna på tången med tjock tejp för att inte repa bryggan).

BYTE AV BATTERIER PÅ EN ÖVERVIKT INDIKATORHANDTAG - 3 MINUTER

NÖDVÄNDIGA VERKTYG

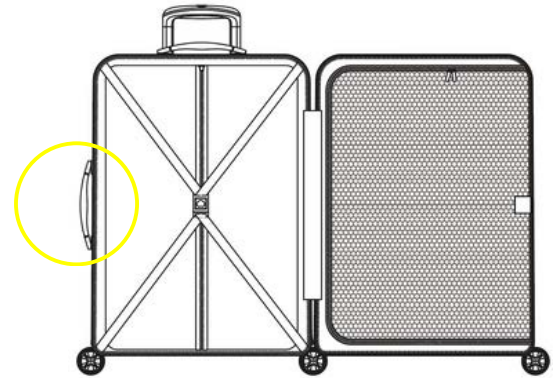

Öppna din resväska helt och vik ut den på mitten på golvet, se till att de två facken är platta...



... för enkel åtkomst till fodret.

2



Öppna försiktigt det inre fodret för att ge direkt åtkomst till handtagets plywood, och var försiktig så att du inte skadar materialet eller omgivande sömmar

DELSEY PARIS

1946



På baksidan av handtaget finns en liten integrerad lucka som ger enkel åtkomst till batterifacket.



Öppna försiktigt denna lilla lucka på baksidan av handtaget och byt ut de två använda knappbatterierna mot nya, se till att notera polariteten (+/-).



Slutligen, stäng luckan på den lilla luckan, du ska höra ett "klick". Stäng fodret och sedan dragkedjan på resväskan.

Sammenfatning

Klik på den type reparation, du gerne vil udføre:

1. UDSKIFTNING AF HJUL
2. UDSKIFTNING AF KOMBINATIONSLÅS
3. UDSKIFTNING AF EN KOMBINATIONSLÅS
CASE MONCEY
4. UDSKIFTNING AF DET EKSTERNE
TROLLESYSTEM
5. UDSKIFTNING AF DET INTEGREREDE
TROLLEY SYSTEM
6. UDSKIFTNING AF HÅNDTAG
7. UDSKIFTNING AF LYNLÅSTRÆKKER
8. UDSKIFTNING AF BATTERIER PÅ
HÅNDTAG MED OVERVÆGTSINDIKATOR

Nødvendigt værktøj

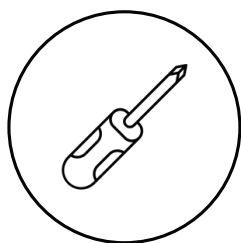

Stjerneskruestrækker



Bidetang

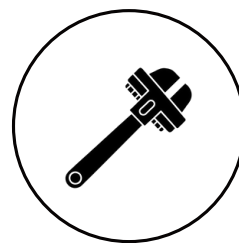

Svensknøgle



Klud

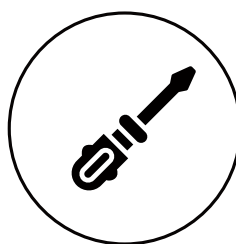

Ligekærvet skruestrækker

ANSVARSRASKRIVELSE

DELSEY PARIS påtager sig intet ansvar for personskade eller skader som følge af dette DIY-reparationssæt eller disse instruktioner, så fortsæt med forsigtighed. Hvis du har spørgsmål til disse instruktioner, kan du altid kontakte kundeservice på et hvilket som helst tidspunkt i reparationsprocessen, så hjælper vi dig igennem!

UDSKIFTNING AF HJUL 4 MINUTTER

NØDVENDIGT VÆRKTØJ

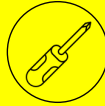

Eksempel på montering af hjul

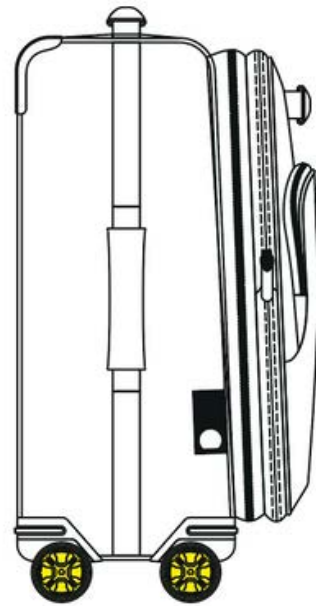

1



Åbn kufferten helt og sørg for at begge rum ligger fladt mod gulvet



...for lettere adgang til foret.

DELSEY PARIS

1 9 4 6

2



Fjern derefter de skruer, der holder hjulet.

3



Fjern hjulet og sæt det nye hjul på i modsat rækkefølge (set indefra) og spænd alle skruerne på plads igen.

4



Luk lynlåsen i foret og til sidst luk kufferten.

UDSKIFTNING AF KOMBINATIONSLÅS 3 MINUTTER

NØDVENDIGT VÆRKTØJ

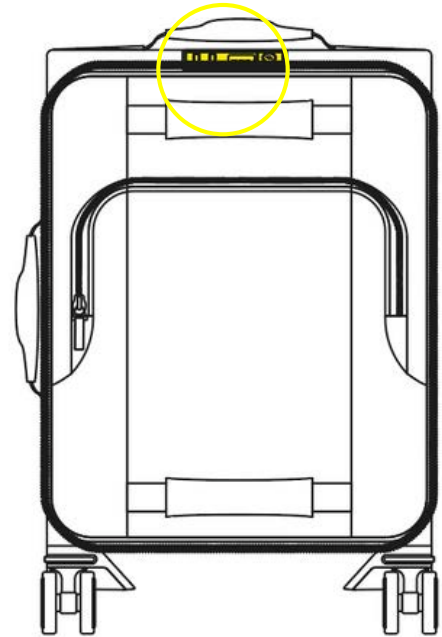

Eksempel på montering af lås

1



Åbn kufferten helt og sørg for at begge rum ligger fladt mod gulvet



...for lettere adgang til foret.

2



Låsen er fastgjort i en lille krydsfinerplade under foret som er holdt på plads af et plastikdæksel (skruehovederne skal beskyttes af tape for at undgå risikoen for at blive løsnet).



Fjern skruerne fra krydsfinerpladen.

3



Fjern den beskadigede lås og fikser den nye lås ved at skrue skruerne i modsat rækkefølge (set indefra). Sæt plastikdækslet på plads igen (skruet af ved punkt 2).

4



Luk lynlåsen i foret og til sidst luk kufferten.

UDSKIFTNING AF EN KOMBINATIONSLÅS CASE MONCEY - 10 MINUTTER

NØDVENDIGT VÆRKTØJ



Åbn kufferten helt og sørg for at begge rum ligger fladt mod gulvet



Løsn foret, som holdes på plads af et lille plastikstykke på hver side af låsen



Åbn foret og skru de 2 skruer af på bagsiden af låsen.



Skru de 2 skruer ud, der nu er tilgængelige.

4



Fjern håndtaget/låsestykket ved at trække nedad.

5



Monter det nye håndtag/lås.

6



Sørg for at låse den højt op mod skallen

7



Sæt alle skruerne på plads igen + de 2 små clips, der holder foringen.

8



Til sidst skal du lukke foret og derefter kuffertens lynlås

UDSKIFTNING AF DET EKSTERNE TROLLESYSTEM- 5 MINUTTER

NØDVENDIGT VÆRKTØJ



1

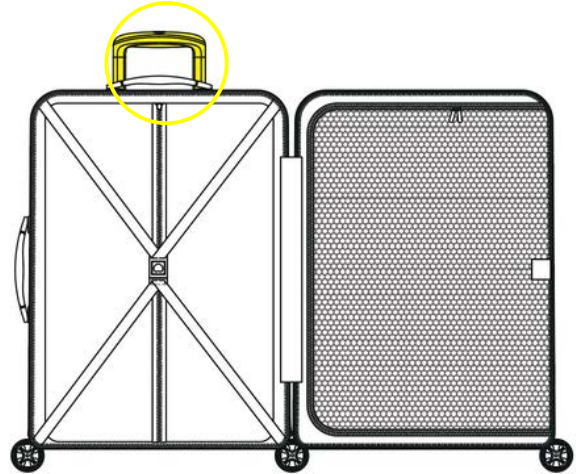

Juster trolleysystemet til det første hak for at gøre det nemmere at trække det ud.

2



Åbn kufferten helt og sørg for at begge rum ligger fladt mod gulvet

...for lettere adgang til foret.

DELSEY PARIS

1946

3



Fjern de øverste skruer

4



Fjern de nederste skruer.

5



Gem alle originale skruer og dele.

6



Fjern delen udefra og monter den nye del i modsat rækkefølge (set indefra).

7



Til sidst skal du lukke foret og derefter kuffertens lynlås.

UDSKIFTNING AF DET INTEGREREDE TROLLEY SYSTEM - 7 MINUTTER

NØDVENDIGT VÆRKTØJ



1

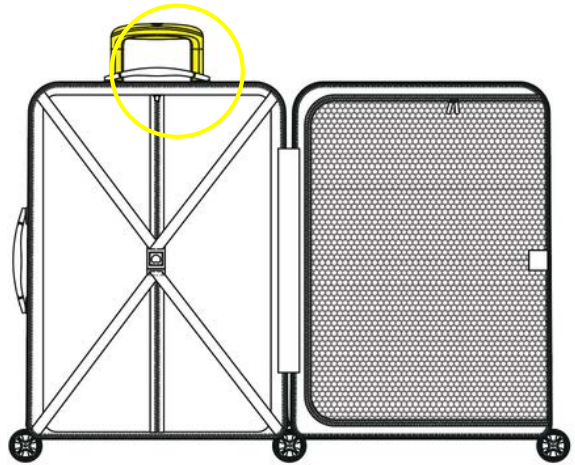

Åbn kufferten helt og sørg for at begge rum ligger fladt mod gulvet for lettere adgang til foret.

2



Skru de øverste og nederste skruer af, der holder trolleysystemet.

DELSEY PARIS

1 9 4 6

3



Installer det nye trolleysystem ved at fastgøre det med krydsfiner og de fjernede skruer.

4



For at afslutte luk foret og derefter din bagage.

DELSEY PARIS

1946

UDSKIFTNING AF HÅNDTAG 4 MINUTTER

NØDVENDIGT VÆRKTØJ

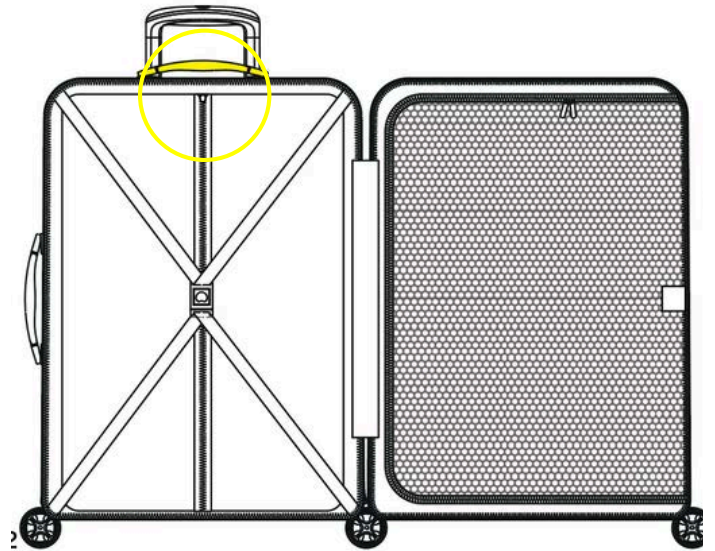

Eksempel på fast håndtag

1



Åbn kufferten helt og sørg for at begge rum ligger fladt mod gulvet

...for lettere adgang til foret.

DELSEY PARIS

1 9 4 6

2



Skru skruerne ud, der holder håndtaget (skruehovedet er muligvis skjult af beskyttelsestape).

3



Fjern håndtaget udefra og sæt det nye håndtag på i modsat rækkefølge (set indefra). Sæt derefter alle skruerne tilbage på plads og stram dem.

4



Luk til sidst foret og derefter kuffertens lynlås.

UDSKIFTNING AF LYNLÅSTRÆKKER 7 MINUTTER

NØDVENDIGT VÆRKTØJ



1

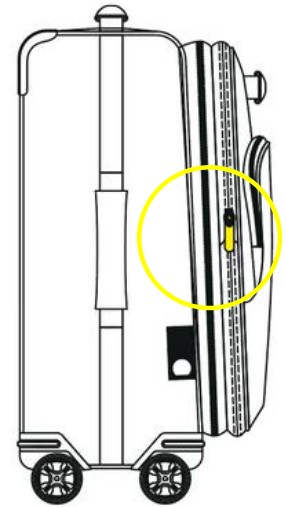

Klip de beskadigede lynlåstrækkere af med en med lille bidetang, og pas på ikke at beskadige selve lynlåsglideren.

2



Løft meget forsigtigt broen 1 eller 2 mm med en ligekærvet skruestrækker eller alternativt en lille tang, så den nye lynlåstrækker kan monteres. Det er vigtigt, at dette gøres meget forsigtigt, da broen risikerer at knække.

3



Kontroller først lynlåstrækkerens retning: højre eller venstre vendt og monter herefter den korrekte lynlåstrækker. Luk forsigtigt igen skyderbroen med en tang (beskyt tænderne på tangen med tykt tape for ikke at ridse broen).

UDSKIFTNING AF BATTERIER PÅ HÅNDTAG MED OVERVÆGTSINDIKATOR- 3 MINUTTER

NØDVENDIGT VÆRKTØJ

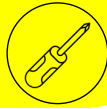

1
Åbn kufferten helt og sørg for at begge rum ligger fladt mod gulvet



... for lettere adgang til foret.



2
Åbn forsigtigt det indvendige foer for at give direkte adgang til håndtagets krydsfiner, og vær forsigtig med ikke at beskadige materialet eller omgivende sømme

DELSEY PARIS

1 9 4 6



På bagsiden af håndtaget giver en lille integreret luge let adgang til batterirummet.



Åbn forsigtigt denne lille luge, der er placeret på bagsiden af håndtaget, og udskift de to brugte knapbatterier med nye, og sørg for at respektere den angivne polaritet (+/-).



Luk til sidst klappen på den lille luge, du skal høre et "klik". Luk foret og derefter lynlåsen på kufferten.

Inhaltsverzeichnis

Klicken Sie auf die Art der Reparatur, die Sie durchführen möchten:

1. AUSTAUSCH EINES RADES
2. AUSTAUSCH EINES ZAHLENSCHLOSSES
3. AUSTAUSCH EINES ZAHLENSCHLOSSES
FALL MONCEY
4. AUSTAUSCH DES EXTERNEN TROLLEY-
SYSTEMS
5. AUSTAUSCH DES INTEGRIERTEN
TROLLEY-SYSTEM
6. AUSTAUSCH EINES GRIFFS
7. AUSTAUSCH EINES
REISSVERSCHLUSSSCHIEBER
8. BATTERIEWECHSEL AN EINEM
ÜBERGEWICHTSANZEIGEGRIFF

Die benötigten tools

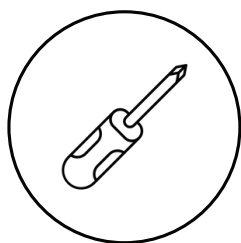

Kreuzschlitz-Schraubendreher



Schneidezange

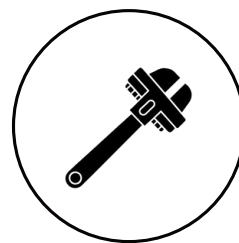

Mehrfachzange



Lappen

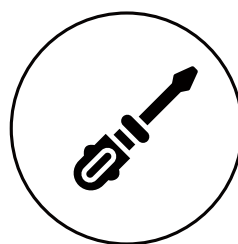

Flacher Schraubendreher

HAFTUNGSAUSSCHLUSS

DELSEY PARIS übernimmt keine Haftung für Verletzungen oder Schäden, die aus diesem DIY-Reparaturset oder dieser Anleitung resultieren, also gehen Sie bitte mit Vorsicht vor. Wenn Sie Fragen zu dieser Anleitung haben, können Sie sich in jeder Phase des Reparaturprozesses an den Kundendienst wenden, der Ihnen gerne weiterhilft!

AUSTAUSCH EINES RADES 4 MINUTEN

DIE BENÖTIGTEN TOOLS



Beispiel einer Radmontage

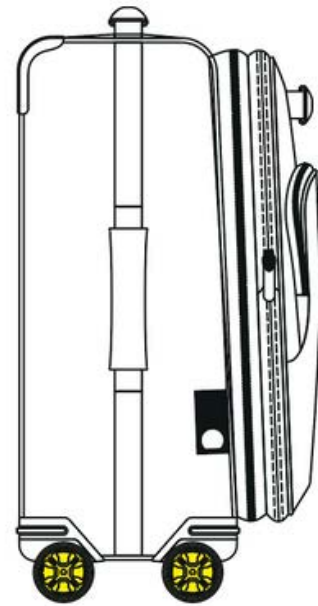

1



Bitte öffnen Sie Ihren Koffer vollständig und falten Sie ihn auf dem Boden in zwei Hälften auseinander. Darauf achten, dass beide Fächer flach liegen...

... um einen einfachen Zugang zum Futter zu ermöglichen.

2



Entfernen Sie dann die Befestigungsschraube(n) vom Rad.

3



Entfernen Sie das Rad, befestigen Sie das neue Teil in der entgegengesetzten Richtung (von innen) und ziehen Sie alle Schrauben wieder fest.

4



Schließen Sie abschließend das Futter und das Gepäck.

AUSTAUSCH EINES ZAHLENSCHLOSSES 3 MINUTEN

DIE BENÖTIGTEN TOOLS

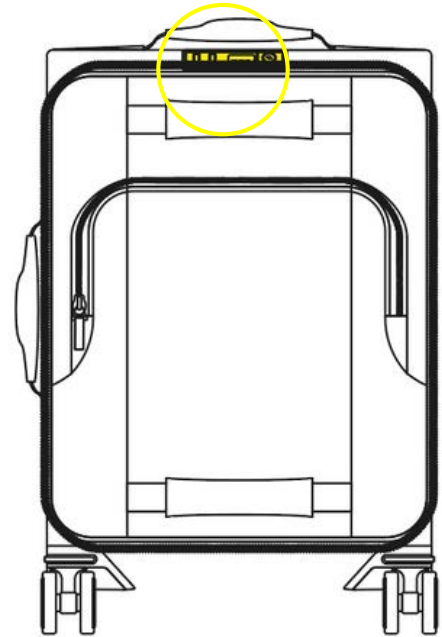

Beispiel einer Schlossmontage...

1



Öffnen Sie Ihren Koffer vollständig und falten Sie ihn auf dem Boden in zwei Hälften auseinander. Darauf achten, dass beide Fächer flach liegen...

...um einen einfachen Zugang zum Futter zu ermöglichen.

2



Greifen Sie auf die Gegenplatte der Befestigung unter dem Futter zu (die Schraubenköpfe können unter einem Klebeband geschützt werden).



Entfernen Sie die Schrauben der Gegenplatte.

3



Entfernen Sie das beschädigte Schloss. Sobald das Schloss entfernt wurde, befestigen Sie das neue Schloss, indem Sie die Schrauben in die entgegengesetzte Richtung zum Herausziehen (von innen) eindrehen. Positionieren Sie die Gegenplatte neu (an Punkt 2 abgeschraubt).

4



Und zum schluss schließen Sie das Futter und das Gepäck.

AUSTAUSCH EINES ZAHLENSCHLOSSES FALL MONCEY - 10 MINUTEN

DIE BENÖTIGTEN TOOLS



Öffnen Sie Ihren Koffer vollständig und falten Sie ihn auf dem Boden in zwei Hälften auseinander. Darauf achten, dass beide Fächer flach liegen...



Öffnen Sie das Futter, lösen Sie die 2 Schrauben unten auf der Rückseite des Schlosses



Ziehen Sie das Futter ab, das von je 1 kleinen Plastikteil auf jeder Seite des Schlosses gehalten wird.



Lösen Sie die beiden Schrauben, die nun zugänglich sind.

4



Entfernen Sie den Griff-/Schlossblock : nach unten ziehen.

5



Installieren Sie den neuen Griff/das neue Schloss

6



Stellen Sie sicher, dass es hoch oben an der Schale befestigt ist

7



Setzen Sie alle Schrauben wieder ein + die 2 kleinen Clips, die das Futter zusammenhalten.

8



Schließen Sie das Innenfutter und dann den Reißverschluss des Koffers.

AUSTAUSCH DES EXTERNEN TROLLEY-SYSTEMS- 5 MINUTEN

DIE BENÖTIGTEN TOOLS

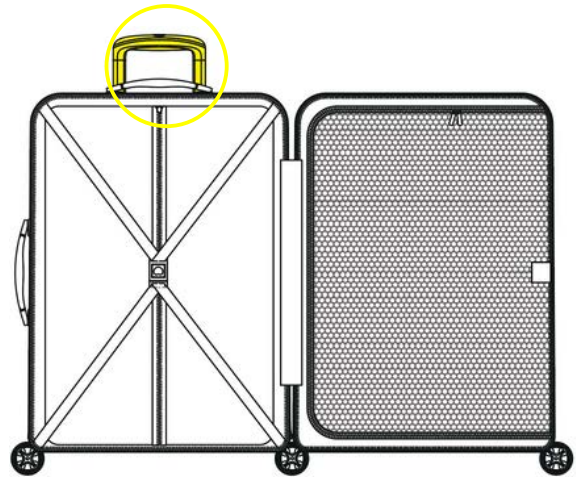
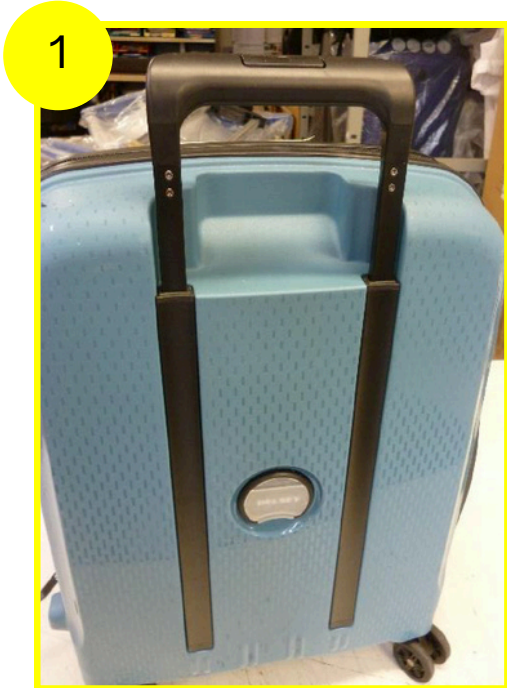

Stellen Sie das Trolley-System auf die erste Raste ein, damit es sich leichter herausziehen lässt.



Öffnen Sie Ihren Koffer vollständig und falten Sie ihn auf dem Boden in zwei Hälften auseinander. Darauf achten, dass beide Fächer flach liegen...

... für einfachen Zugang zum Futter

3



Entfernen Sie die oberen Schrauben

4



Entfernen Sie die unteren Schrauben

5



Bewahren Sie alle
Originalschrauben und -teile auf.

6



Entfernen Sie das Teil von außen
und bauen Sie das neue Teil in
umgekehrter Richtung (von innen)
wieder zusammen.

7



Schließen Sie zum Schluss das
Innenfutter und dann den
Reißverschluss des Koffers.

AUSTAUSCH DES INTEGRIERTEN TROLLEY-SYSTEM - 7 MINUTEN

DIE BENÖTIGTEN TOOLS

1

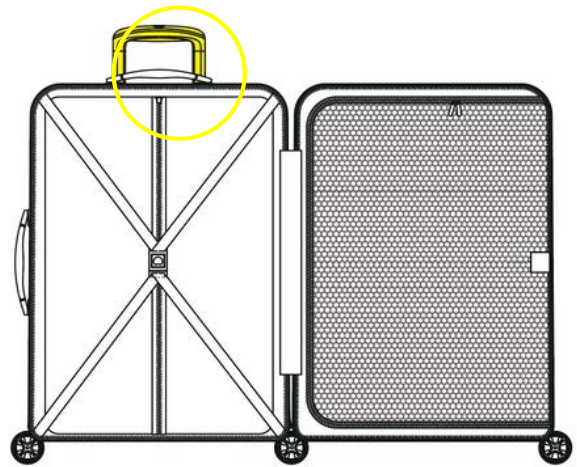

Öffnen Sie Ihren Koffer vollständig und falten Sie ihn in zwei Hälften auseinander. Darauf achten, dass die beiden Fächer flach sind, damit Sie leicht an das Futter gelangen können.

2



Lösen Sie die oberen und unteren Schrauben, mit denen das Trolley-System befestigt ist.

3



Installieren Sie das neue Trolley-System, indem Sie es mit der Gegenplatte und den entfernten Schrauben befestigen.

4



Schließen Sie das Futter und dann Ihr Gepäck.

AUSTAUSCH EINES GRIFFS 4 MINUTEN

DIE BENÖTIGTEN TOOLS

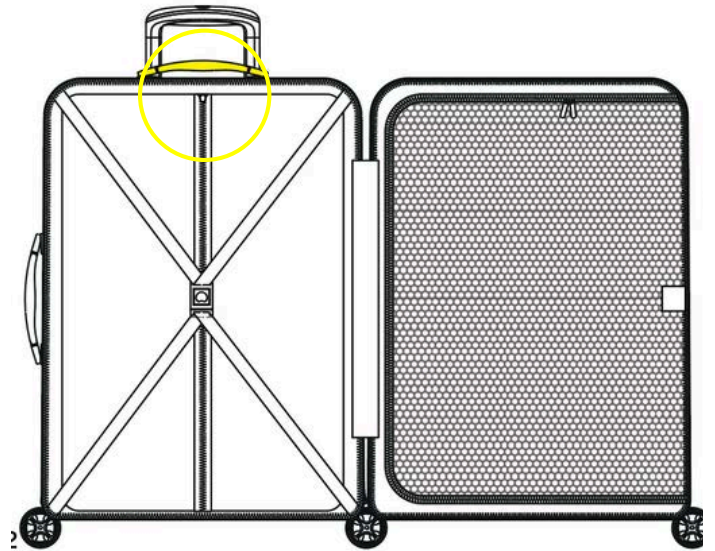

Beispiel für einen festen Griff

1



Öffnen Sie Ihren Koffer vollständig und falten Sie ihn auf dem Boden auseinander. Stellen Sie sicher, dass beide Seiten flach liegen.

...für einen einfachen Zugang zum Futter.

2



Lösen Sie die Schrauben, mit denen der Griff befestigt ist (Schraubenkopf möglicherweise durch Schutzband verdeckt).

3



4



ziehen Sie den Griff von außen ab und befestigen Sie das neue Teil in umgekehrter Reihenfolge (von innen). Bringen Sie dann alle Schrauben wieder an, indem Sie sie festziehen.

Schließen Sie das Futter und dann den Reißverschluss des Koffers.

AUSTAUSCH EINES REISSVERSCHLUSSSCHIEBE - 7 MINUTEN

DIE BENÖTIGTEN TOOLS

1

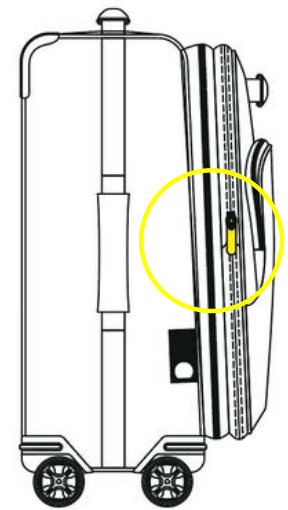

Schneiden Sie den beschädigten Reißverschluss mit einer Schneidezange durch und achten Sie dabei darauf, die Spitze des Schiebers nicht zu beschädigen.

2



Heben Sie die Spitze des Schiebers mit einem flachen Schraubendreher vorsichtig um 1 oder 2 mm an, damit der neue Reißverschlusschieber montiert werden kann.

3



Schließen Sie die Spitze mit einer Mehrfachzange (schütze die Zähne der Zange mit einem dicken Klebeband, damit die Spitze nicht zerkratzt wird).

BATTERIEWECHSEL AN EINEM ÜBERGEWICHTSANZEIGEGRIFF - 3 MINUTEN

DIE BENÖTIGTEN TOOLS

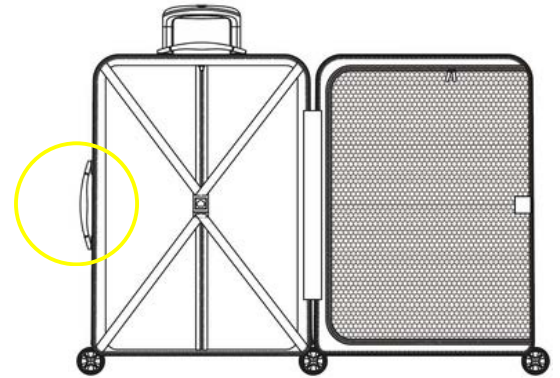

Öffnen Sie Ihren Koffer vollständig und falten Sie ihn auf dem Boden in zwei Hälften auseinander. Darauf achten, dass beide Fächer flach liegen...



... für einfachen Zugang zum Futter.



Öffnen Sie vorsichtig das Innenfutter, um direkten Zugang zur Gegenplatte zu ermöglichen, und achten Sie darauf, das Material oder die umliegenden Nähte nicht zu beschädigen



Auf der Rückseite des Griffs befindet sich eine kleine integrierte Klappe. Einfachen Zugang zum Batteriefach.



Öffnen Sie vorsichtig diese kleine Klappe auf der Rückseite des Griffs und ersetzen Sie die beiden verbrauchten Knopfzellen durch neue. Achten Sie dabei auf die angegebene Polarität (+/-).



Schließen Sie die Klappe der kleinen Luke, Sie sollten ein „Klick“ hören. Schließen Sie das Innenfutter und dann den Reißverschluss des Koffers.

SINTESI

Clicca sul tipo di riparazione che desideri effettuare:

1. SOSTITUZIONE DI UNA RUOTA GIREVOLE
2. SOSTITUZIONE DI UNA SERRATURA A COMBINAZIONE
3. SOSTITUZIONE DI UNA SERRATURA A COMBINAZIONE LINEA MONCEY
4. SOSTITUZIONE DEL SISTEMA TROLLEY/
CARRELLO ESTERNO ALLA VALIGIA
5. SOSTITUZIONE DEL SISTEMA TROLLEY/
CARRELLO INTEGRATO ALLA VALIGIA (INTERNO)
6. SOSTITUZIONE DI UNA MANIGLIA
7. SOSTITUZIONE DI UN TIRANTE CERNIERA
TROLLEY
8. SOSTITUZIONE DELLE BATTERIE SU UNA MANIGLIA
CON INDICATORE DI SOVRAPPESO ("OVERWEIGHT
INDICATOR" INTEGRATO)

STRUMENTI RICHIESTI

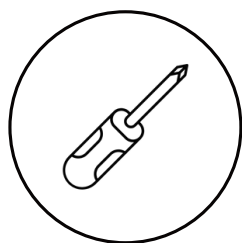

Cacciavite a croce



Pinze Da Taglio/
Tronchese

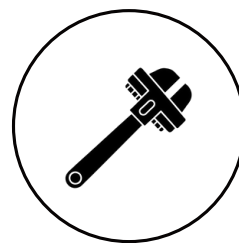

Pinza multipresa



Straccio

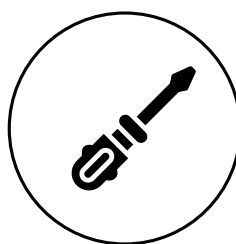

Cacciavite piatto

Disclaimer

DELSEY PARIS non si assume alcuna responsabilità per lesioni o danni derivanti da questo kit di riparazione fai-da-te o da queste istruzioni, pertanto si prega di procedere con cautela. Se avete domande su queste istruzioni, potete sempre contattare il servizio clienti in qualsiasi fase del processo di riparazione e vi aiuteremo!

SOSTITUZIONE DI UNA RUOTA GIREVOLE 4 MINUTI

STRUMENTI RICHIESTI

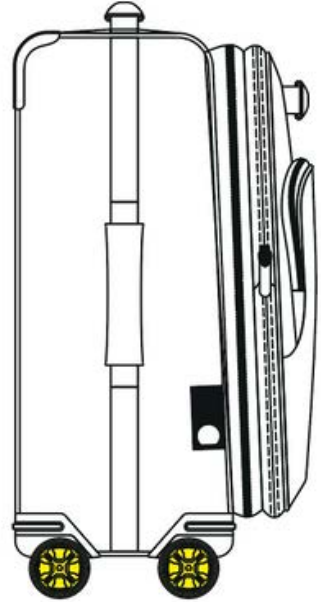

Esempio di montaggio di una ruota

1



Si prega di aprire completamente la valigia e di dispiegarla sul pavimento con i due scomparti ben aperti, assicurandosi che entrambi gli scomparti siano ben distesi...

... per consentire un facile accesso alla zip della fodera.

2



Quindi rimuovere la(e) vite(i) di fissaggio dalla ruota.

3



Rimuovere la ruota danneggiata dall'esterno della valigia e montare la nuova partendo dalla direzione opposta (ossia verso l'interno) e serrare quindi nuovamente tutte le viti.

4



Infine, chiudere la fodera e il bagaglio.

SOSTITUZIONE DI UNA SERRATURA A COMBINAZIONE - 3 minuti

STRUMENTI RICHIESTI

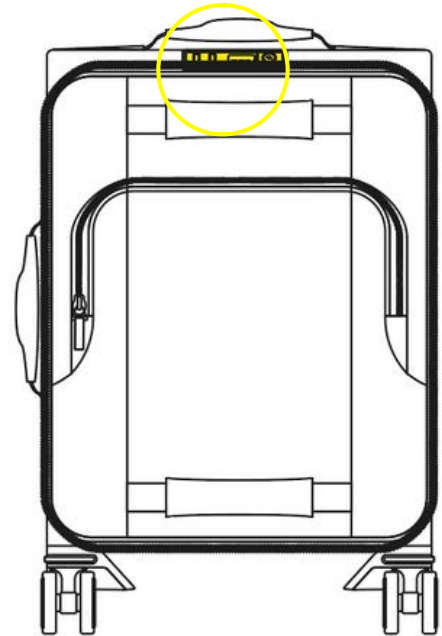

Esempio di montaggio di una serratura...

1



Si prega di aprire completamente la valigia e di dispiegarla sul pavimento con i due scomparti ben aperti, assicurandosi che entrambi gli scomparti siano ben distesi...

...per consentire un facile accesso alla zip della fodera.

2



Individuare la parte in compensato dove è fissata la combinazione sotto la fodera (le teste delle viti devono essere protette con nastro adesivo per evitare il rischio di spostamento).



Rimuovere le viti dal compensato.

3



Rimuovere la serratura danneggiata. Una volta rimossa la serratura, fissare la nuova serratura avvitando le viti nel senso opposto all'estrazione (ossia dall'interno). riposizionare la contropiastra di compensato (svitata al punto 2).

4



E infine chiudere la fodera e il bagaglio.

SOSTITUZIONE DI UNA SERRATURA A COMBINAZIONE LINEA MONCEY 10 MINUTI

STRUMENTI RICHIESTI



1
Si prega di aprire completamente la valigia e di dispiegarla sul pavimento con i due scomparti ben aperti, assicurandosi che entrambi gli scomparti siano ben distesi...

Sganciare il rivestimento che è tenuto in posizione da 1 piccolo pezzo di plastica su ciascun lato della serratura.



2
Aprire il rivestimento, svitare le 2 viti in basso sul retro della serratura.

3
Svitare le 2 viti che ora sono risultano visibili/accessibili

4



Rimuovere il blocco maniglia/serratura tirando verso il basso.

5



Installare la nuova maniglia/serratura.

6



Assicurarsi di fissare il nuovo blocco combinazione in alto contro il guscio della valigia

7



Rimettere a posto tutte le viti + le 2 piccole clip che fissano il rivestimento (rimosse in precedenza)

8



Infine chiudere la fodera e poi la cerniera della valigia.

SOSTITUZIONE DEL SISTEMA TROLLEY/ CARRELLO ESTERNO ALLA VALIGIA- 5 MINUTI

STRUMENTI RICHIESTI

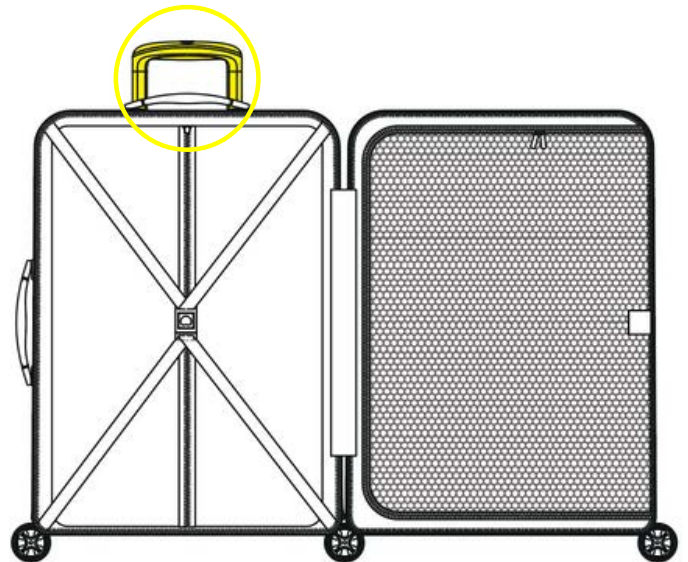

Posizionare il traino sistema Trolley alla prima tacca partendo dal basso, per facilitarne l'estrazione.



Si prega di aprire completamente la valigia e di dispiegarla sul pavimento con i due scomparti ben aperti, assicurandosi che entrambi gli scomparti siano ben distesi...

... per consentire un facile accesso alla zip della fodera.

3



Rimuovere le viti superiori.

4



Rimuovere le viti inferiori.

5



Conservare tutte le viti e le parti originali.

6



Rimuovere la parte dall'esterno e rimontare la nuova parte nella direzione opposta (verso l'interno).

7



Infine chiudere la fodera e poi la cerniera della valigia.

SOSTITUZIONE DEL SISTEMA TROLLEY/ CARRELLO INTEGRATO ALLA VALIGIA (INTERNO) 7 MINUTI

STRUMENTI RICHIESTI



1

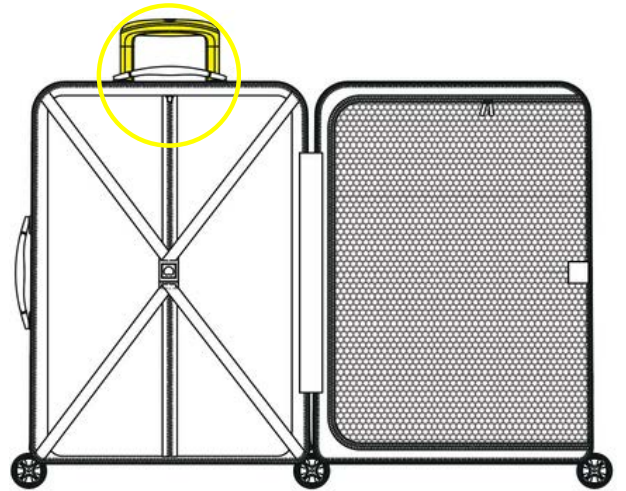

Aprire completamente la valigia e dispiegarla a metà, assicurandosi che i due scomparti siano ben distesi, per un facile accesso alla fodera ed alla sua zip.

2

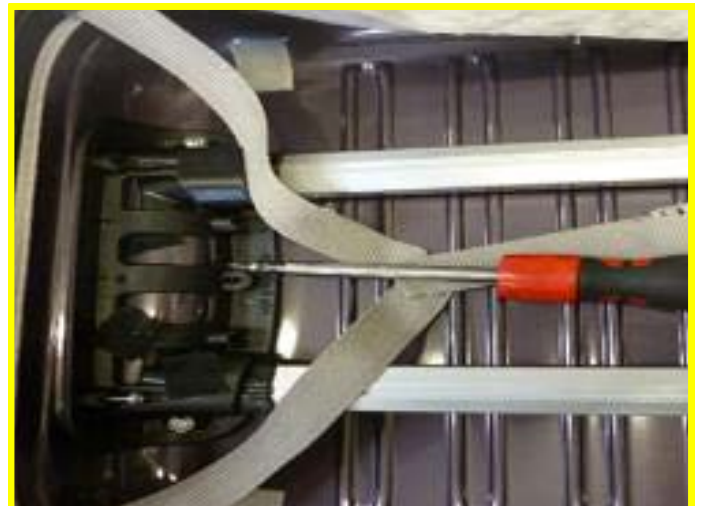

Svitare le viti superiori e inferiori che fissano il sistema trolley..

3



Installare il nuovo carrello del sistema trolley fissandolo alla parte in compensato tramite le viti rimosse.

4



Per finire richiudere la fodera e poi il tuo bagaglio.

SOSTITUZIONE DI UNA MANIGLIA 4 MINUTI

STRUMENTI RICHIESTI



Esempio di maniglia fissa

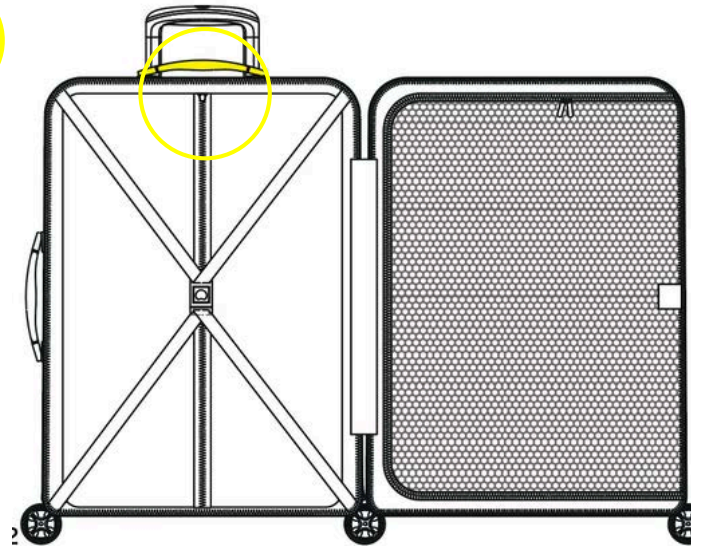

Si prega di aprire completamente la valigia e di dispiegarla sul pavimento con i due scomparti ben aperti, assicurandosi che entrambi gli scomparti siano ben distesi...



...per consentire un facile accesso alla zip della fodera.

2



Svitare le viti che fissano la maniglia (la testa della vite potrebbe eventualmente essere nascosta da nastro protettivo).

3



4



Rimuovere la maniglia dall'esterno e inserire la nuova parte nella direzione opposta (verso l'interno). Quindi rimettere tutte le viti come in origine e stringerle alla maniglia.

Infine, chiudere la fodera e poi la cerniera della valigia.

SOSTITUZIONE DI UN TIRANTE CERNIERA TROLLEY - 7 MINUTI

STRUMENTI RICHIESTI

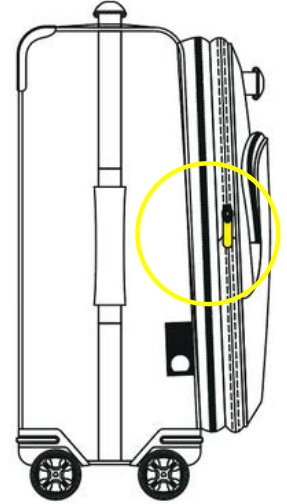

1



Tagliare il tirante della cerniera danneggiato con una pinza da taglio o un tronchese, facendo attenzione a non danneggiare il cursore scorrevole della zip.

2



Sollevare delicatamente il cursore scorrevole di 1 o 2 mm con un cacciavite a testa piatta in modo da poter montare il nuovo tirante della cerniera.

3



Controllare prima la direzione della parte: destra o sinistra. Chiudere il cursore scorrevole utilizzando una pinza (proteggere i denti della pinza con nastro adesivo spesso per non graffiare il cursore).

SOSTITUZIONE DELLE BATTERIE SU UNA MANIGLIA CON INDICATORE DI SOVRAPPESO ("OVERWEIGHT INDICATOR" INTEGRATO)- 3 MINUTI

STRUMENTI RICHIESTI

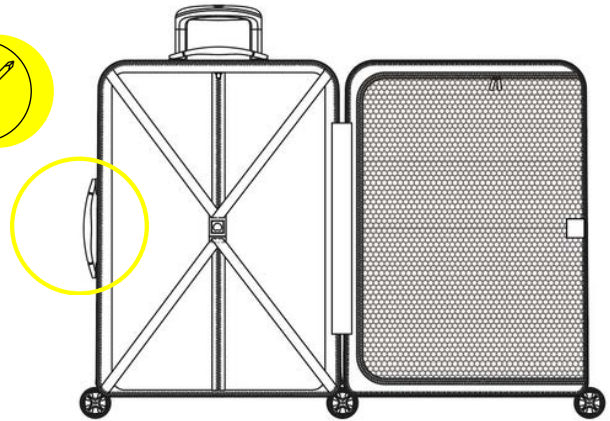

1



Si prega di aprire completamente la valigia e di dispiegarla sul pavimento con i due scomparti ben aperti, assicurandosi che entrambi gli scomparti siano ben distesi...



...per consentire un facile accesso alla zip della fodera.

2



Aprire con attenzione la zip della fodera interna per consentire l'individuazione della parte in compensato adiacente alla maniglia facendo attenzione a non danneggiare il materiale o le cuciture circostanti



Sul retro dell'impugnatura della maniglia, un piccolo sportello in esso integrato consente un facile accesso al vano batterie.



Aprire con cautela questo piccolo sportello situato nella parte posteriore della maniglia e sostituire le due batterie a bottone usate/scariche con delle nuove, avendo cura di rispettare la polarità indicata (+/-).



Infine, chiudere lo sportello del vano portabatterie (dovresti sentire un "clic" laddove fatto nella maniera corretta). Chiudere infine la fodera e poi la cerniera della valigia.

摘要

选择您想要维修的类型：

1. 更换脚轮
2. 更换密码锁
3. 密码锁组件示例... (手把+锁)
4. 更换外置拉杆系统
5. 更换内置拉杆系统
6. 更换手柄
7. 更换拉链片
8. 更换称重手柄电池

词典

所需工具： 十字螺丝刀或内六角扳手

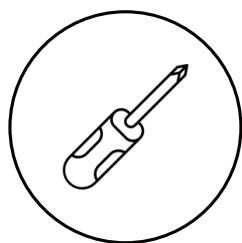

十字螺丝刀



钳子

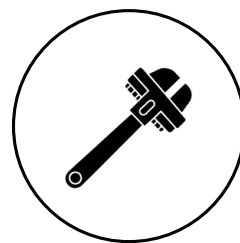

内六角扳手



抹布



平头螺丝刀

免責聲明

DELSEY PARIS 不承擔因本 DIY 維修套件或這些說明書所造成的傷害或損害的責任，因此請謹慎操作。如果您對這些說明有任何疑問，您可以在維修過程中的任何階段隨時聯絡客戶服務部，我們將協助您完成維修！

更换脚轮 - 4分钟

所需工具:



脚轮组件示例

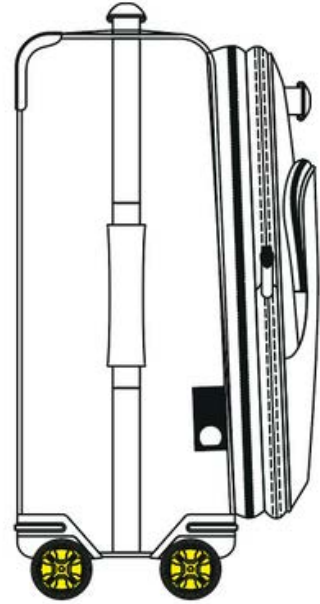

1



请打开您的行李箱，并将其展开且平铺在地板上



以便打开内衬

2



然后从脚轮上拆下固定螺丝

3



拆下脚轮，并从外部安装新的脚轮，
然后从内部将所有螺钉拧紧固定。

4



最后，合上内衬和行李箱。

更换密码锁 - 3分钟

所需工具:



密码锁组件示例... (单锁)

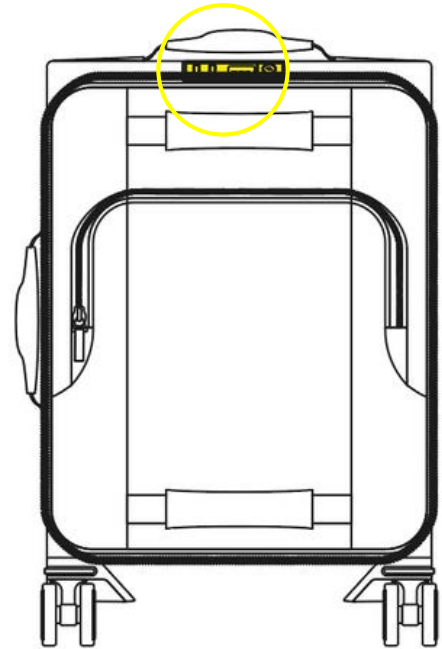

1



请打开您的行李箱，并将其展开且平铺在地板上



以便打开内衬

2



找到内衬下的密码锁部位



从密码锁内盒上拆下螺丝

3



从外部拆下损坏的密码锁。装上新锁后，从内部扣上密码锁内盒，并拧紧螺丝以固定新锁。

4



最后，合上内衬和行李箱。

密码锁组件示例... (手把+锁) - 10分钟

所需工具:



1



请打开您的行李箱，并将其展开且平铺在地板上



找到内衬下的密码锁部位，首先拧开固定内衬的塑胶片上的一个小螺丝

2



打开内衬后，拧下密码锁内部上下各 2 个螺丝。

4



从外部拉动并拆下手柄/锁块

5



安装新的手柄/锁块

6



确保将其固定在原有位置上

7



先拧紧固定手柄/锁体的四个螺丝，再拧紧固定内衬的小螺丝

8



最后，合上内衬和行李箱。

更换外置拉杆系统- 5分钟

所需工具:



1

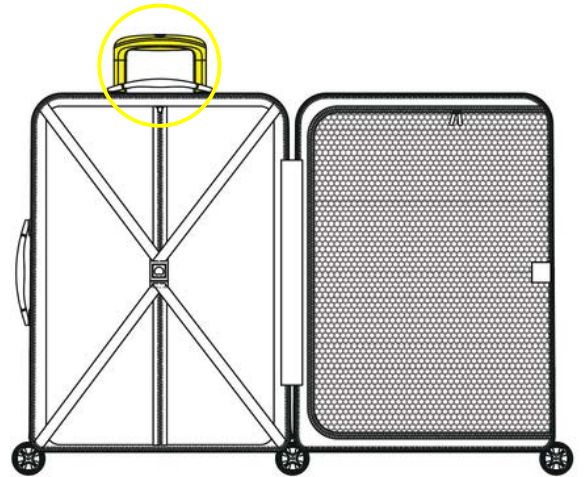

将拉杆拉至第一截更容易拆卸。

2



请打开您的行李箱，并将其展开且平铺在地板上

以便打开内衬

3



拆下拉杆顶部螺丝

4



拆下拉杆底部螺丝。

5



保留所有原装螺丝和其他配件。

6



从外部拆下拉杆，然后装上新的拉杆并拧上所有螺丝固定。

7



最后，合上内衬和行李箱。

更换内置拉杆系统- 7分钟

所需工具:



1

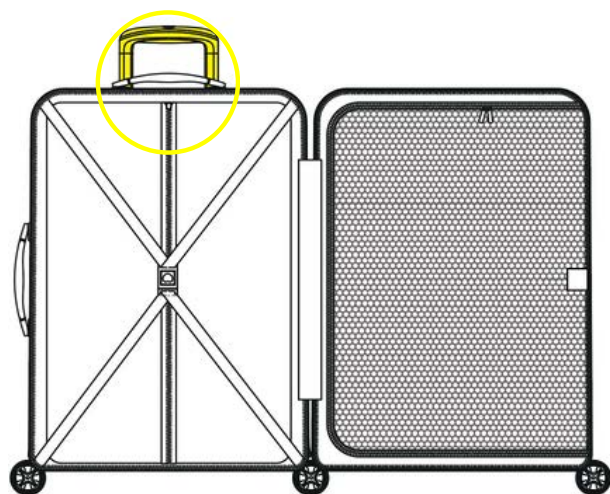

请打开您的行李箱，并将其展开且平铺在地板上，以便打开内衬

2



拧下固定拉杆的顶部和底部螺丝

3



安装固定新的拉杆并拧紧螺丝

4



最后，合上内衬和行李箱。

更换手柄 - 4分钟

所需工具：



固定手柄示例

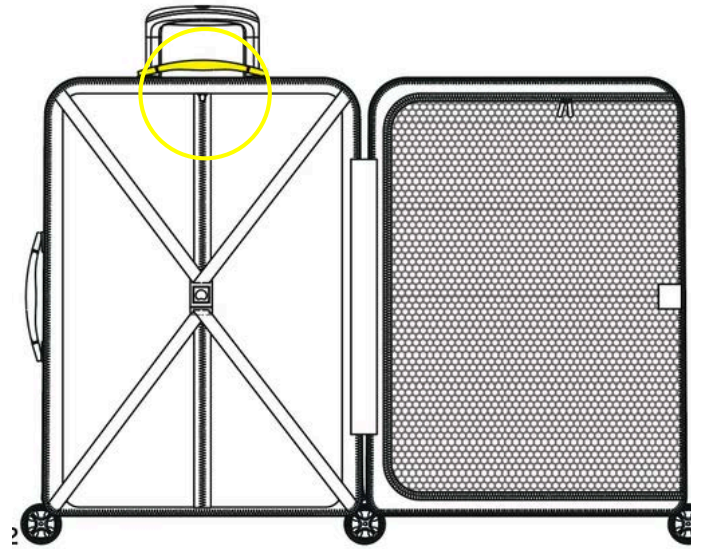

1



请打开您的行李箱，并将其展开且平铺在地板上，



以便打开内衬

2



拧下固定手柄的螺丝

3



从外部拆下手柄并安装新的手柄，然后拧紧所有的螺丝固定。

4



最后，合上内衬和行李箱。

更换拉链片 - 7分钟

所需工具:

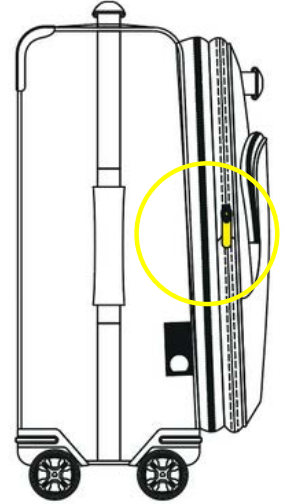
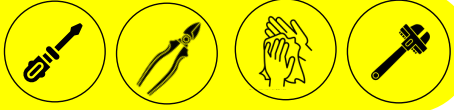

1



用钳子或剪刀剪掉损坏的拉链片，注意不要损坏拉链头。

2



用平头螺丝刀轻轻将拉链头翘起 1 或 2 毫米，以便安装新的拉链片。



事先检查拉链片的左右，拉链片分左半边和右半边。用钳子夹紧拉链头（用厚胶带或毛巾包裹钳齿，可以避免刮伤拉链头）。

更换称重手柄电池 - 3分钟

所需工具：

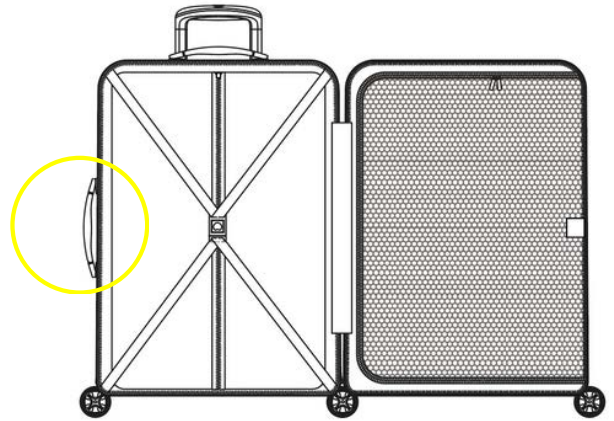

1



请打开您的行李箱，并将其展开且平铺在地板上，



以便打开内衬

2



找到手柄位置，



手柄一侧有一个小型集成盒即电池所在位置。



小心打开集成盒盖子，然后更换新的纽扣电池，确保电池正负极不要装反。



最后，盖上集成盒盖子，听到“咔哒”声即为成功。合上内衬和行李箱

目录

選擇您想要維修的類型：

1. 更換腳輪
2. 更換密碼鎖
3. 密碼鎖元件示例... (手把+鎖)
4. 更換外置拉杆系統
5. 更換內置拉杆系統
6. 更換手柄
7. 更換拉鍊片
8. 更換稱重手柄電池

所需工具：十字螺絲刀 或內六角扳手

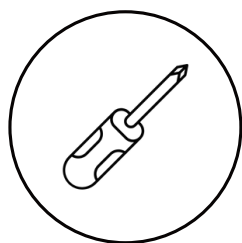

十字螺絲刀



鉗子

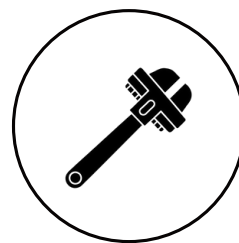

內六角扳手



抹布



平頭螺絲刀

免责声明

巴黎德西不承担因本 DIY 修理包或这些说明而造成的伤害或损失，因此请谨慎操作。如果您对这些说明有任何疑问，您可以在维修过程的任何阶段联系客服，我们将帮助您完成维修！

更換腳輪 - 4分鐘

所需工具



腳輪組件示例

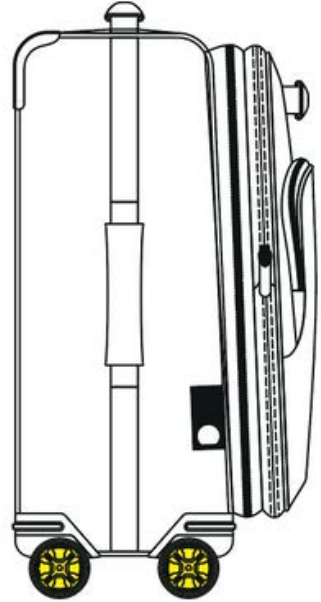

請打開您的行李箱，並將其展開且平鋪在地板上



以便打開內襯

DELSEY PARIS

1946

2



然後從腳輪上拆下固定螺絲

3



拆下腳輪，並從外部安裝新的腳輪，
然後從內部將所有螺釘擰緊固定。

4



最後，合上內襯和行李箱。

更換密碼鎖 - 3分鐘

所需工具

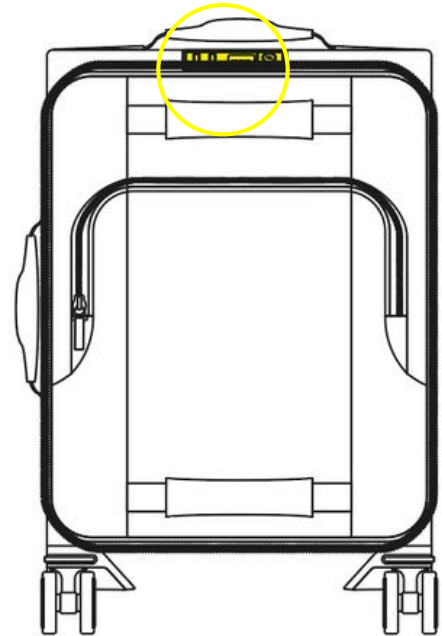
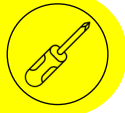

密碼鎖元件示例... (單鎖)

1



請打開您的行李箱，並將其展開且平鋪在地板上

以便打開內襯

2



找到內襯下的密碼鎖部位



從密碼鎖內盒上拆下螺絲

3



從外部拆下損壞的密碼鎖。裝上新鎖後，從內部扣上密碼鎖內盒，並擰緊螺絲以固定新鎖。

4



最後，合上內襯和行李箱。

密碼鎖元件示例... (手把+鎖) - 10分鐘

所需工具



1



請打開您的行李箱，並將其展開且平鋪在地板上



找到內襯下的密碼鎖部位，首先擰開固定內襯的塑膠片上的一個小螺絲

2



3



打開內襯後，擰下密碼鎖內部上下各 2 個螺絲。

4



從外部拉動並拆下手柄/鎖塊

5



安裝新的手柄/鎖塊

6



確保將其固定在原有位置上

7



先擰緊固定手柄/鎖體的四個螺絲，再擰緊固定內襯的小螺絲。

8



最後，合上內襯和行李箱。

更換外置拉杆系統 - 5分鐘

所需工具

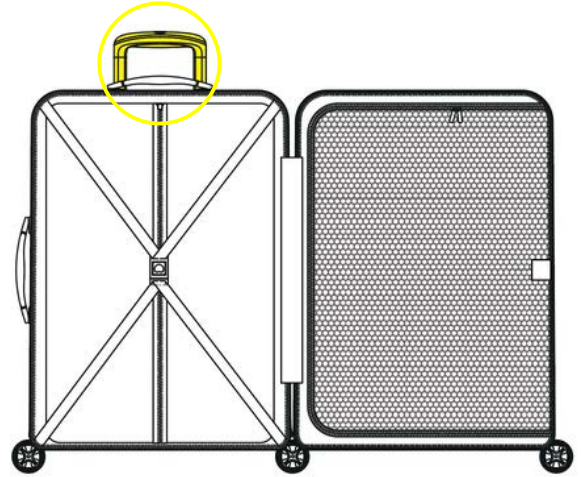
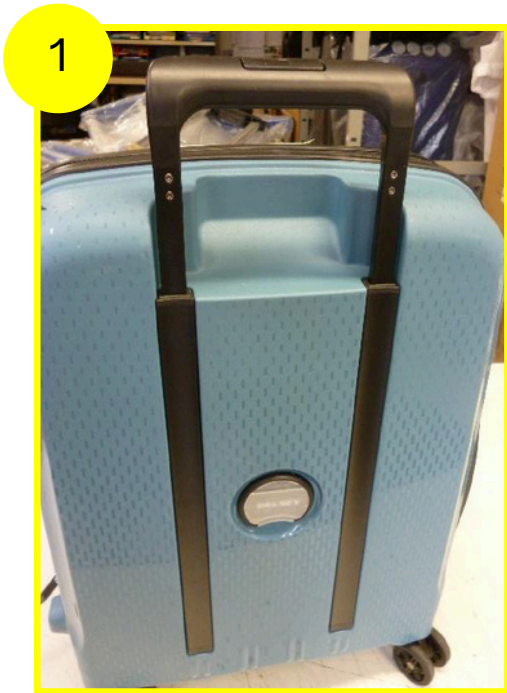

將拉杆拉至第一截更容易拆卸



請打開您的行李箱，並將其展開且平鋪在地板上

以便打開內襯

3



拆下拉杆頂部螺絲

4



拆下拉杆底部螺絲。

5



保留所有原裝螺絲和其他配件。

6



從外部拆下拉杆，然後裝上新的拉杆並擰上所有螺絲固定

7



最後，合上內襯和行李箱。

更換內置拉杆系統 - 7分鐘

所需工具



1

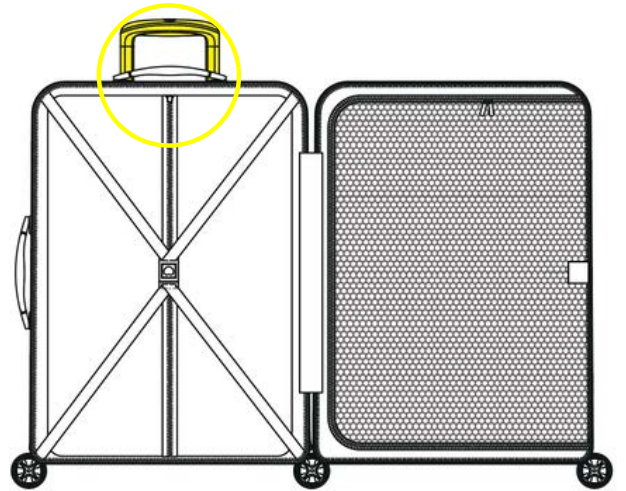

請打開您的行李箱，並將其展開且平鋪在地板上，以便打開內襯

2

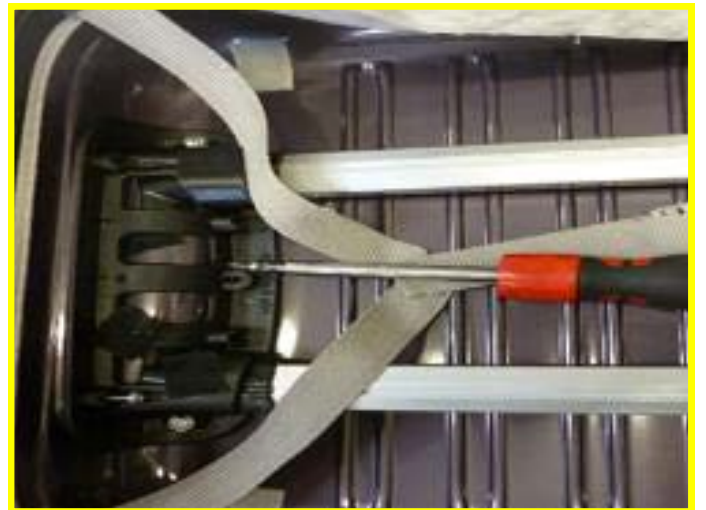

擰下固定拉杆的頂部和底部螺絲

3



安裝固定新的拉杆並擰緊螺絲

4



最後，合上內襯和行李箱。

更換手柄 - 4分鐘

所需工具



固定手柄示例

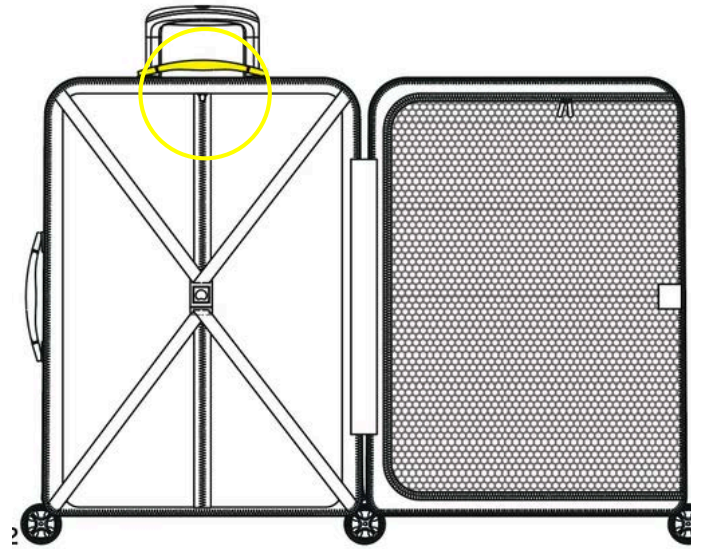

1



請打開您的行李箱，並將其展開且平鋪在地板上



以便打開內襯

2



擰下固定手柄的螺絲

3



從外部拆下手柄並安裝新的手柄，然後擰緊所有的螺絲固定。

4



最後，合上內襯和行李箱。

更換拉鍊片 - 7分鐘

所需工具



1

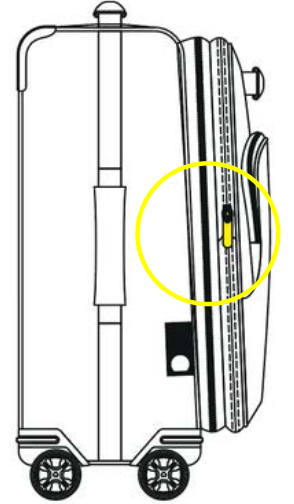

用鉗子或剪刀剪掉損壞的拉鍊片，注意不要損壞拉鍊頭。

2



用平頭螺絲刀輕輕將拉鍊頭翹起 1 或 2 毫米，以便安裝新的拉鍊片。



事先檢查拉鍊片的左右，拉鍊片分左半邊和右半邊。用鉗子夾緊拉鍊頭（用厚膠帶或毛巾包裹鉗齒，可以避免刮傷拉鍊頭）。

更換稱重手柄電池 - 3分鐘

所需工具

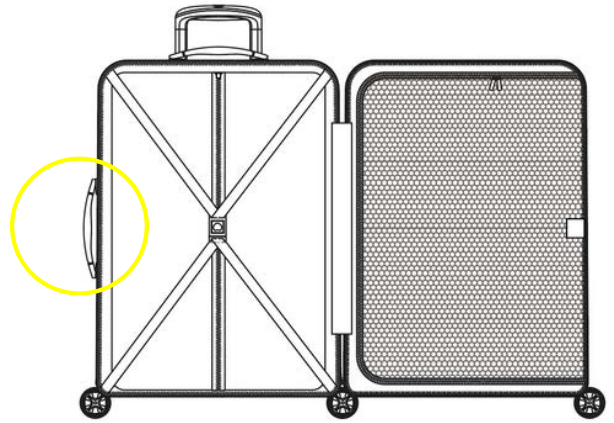

請打開您的行李箱，並將其展開且平鋪在地板上，



以便打開內襯



找到手柄位置，



手柄一側有一個小型集成盒即電池所在位置。



小心打開集成盒蓋子，然後更換新的鈕扣電池，確保電池正負極不要裝反。



最後，蓋上集成盒蓋子，聽到“啵嗒”聲即為成功。合上內襯和行李箱

सारांश

आप जिस प्रकार की मरम्मत करना चाहते हैं उस पर क्लिक करें:

1. कैस्टर व्हील का प्रतिस्थापन
2. कॉम्बिनेशन लॉक का प्रतिस्थापन
3. कॉम्बिनेशन लॉक का प्रतिस्थापन मामला मंसी
4. बाहरी ट्रॉली प्रणाली का प्रतिस्थापन
5. एकीकृत का प्रतिस्थापन ट्रॉली प्रणाली
6. एक हैंडल का प्रतिस्थापन
7. स्लाइडर पुल का प्रतिस्थापन
8. ओवरवेट संकेतक हैंडल पर बैटरियों का प्रतिस्थापन

आवश्यक उपकरण

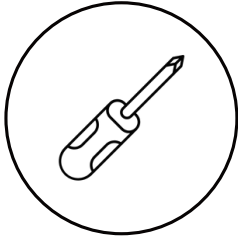

पेचकश क्रूसिफ़ॉर्म



सरौता काटना



प्लायर्स पावर स्ट्रिप



खपरैल



पेचकस फ्लैट

अस्वीकरण

डेल्टा पेरिस इस DIY मरम्मत किट या इन निर्देशों के परिणामस्वरूप होने वाली चोट या क्षति के लिए ज़िम्मेदारी नहीं लेता है, इसलिए कृपया सावधानी से आगे बढ़ें। यदि आपके पास इन निर्देशों के बारे में कोई प्रश्न हैं, तो आप मरम्मत प्रक्रिया के किसी भी चरण में हमेशा 251 ग्राहक सेवा से संपर्क कर सकते हैं और हम इसमें आपकी मदद करेंगे!

कैस्टर व्हील का प्रतिस्थापन - 4 मिनट

आवश्यक उपकरण



व्हील असेंबली का उदाहरण

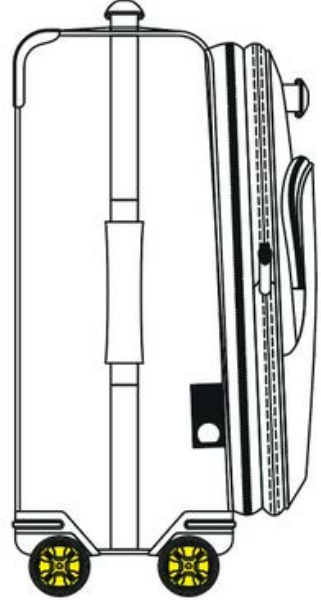

1



कृपया अपना सूटकेस पूरा खोलें और इसे फर्श पर आधा फैला दें, यह सुनिश्चित करते हुए कि दोनों डिब्बे समतल हों...



...लाइनिंग तक आसान पहुंच की अनुमति देने के लिए।

2



फिर पहिए से रिटेनिंग स्कू हटा दें।

3



पहिये को हटा दें और नए हिस्से को विपरीत दिशा में (अंदर से) जोड़ दें और सभी स्कू को वापस अपनी जगह पर कस दें।

4



अंत में, अस्तर और सामान को बंद कर दें।

कॉम्बिनेशन लॉक का प्रतिस्थापन - 3 मिनट

आवश्यक उपकरण

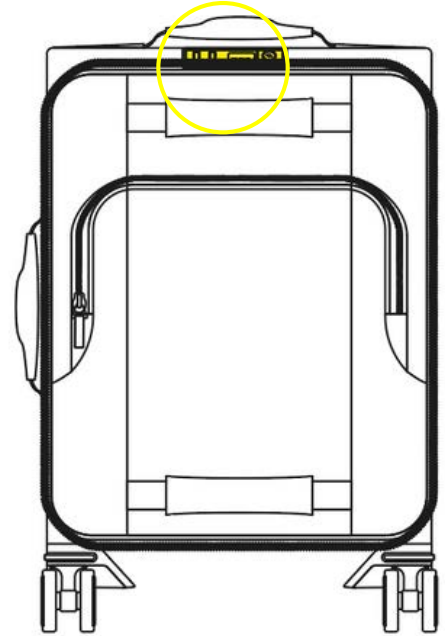

लॉक असेंबली का उदाहरण...

1



अपने सूटकेस को पूरा खोलें और इसे फर्श पर आधा खोल दें, यह सुनिश्चित करते हुए कि दोनों डिब्बे समतल हों।

...लाइनिंग तक आसान पहुंच की अनुमति देने के लिए।

2



लाइनर के नीचे फास्टर के प्लाईवुड तक पहुंचें (स्कू हेड्स को उखाड़ने के जोखिम से बचने के लिए टेप के नीचे संरक्षित किया जाना चाहिए)।



प्लाईवुड से पेंच हटा दें।

3



क्षतिग्रस्त ताले को हटा दें। एक बार ताला हटा दिया जाए, तो निकालने की विपरीत दिशा में (अंदर से) स्कू लगाकर नया ताला लगा दें। काउंटर प्लेट को पुनः व्यवस्थित करें (बिंदु 2 पर स्कू को हटा दें)।

4



और अंत में, अस्तर और सामान को बंद कर दें।

कॉम्बिनेशन लॉक का प्रतिस्थापन मामला मंसी - 10 मिनट

आवश्यक उपकरण



1



अपने सूटकेस को पूरा खोलें और इसे फर्श पर आधा फैलाएं, यह सुनिश्चित करते हुए कि दोनों डिब्बे सपाट हैं...



लाइनर को खोल दें जो ताले के प्रत्येक तरफ 1 छोटे प्लास्टिक के टुकड़े से बंधा हुआ है।

2



लाइनर खोलें, ताले के पीछे नीचे लगे 2 स्कू खोल दें।

3



अब पहुंच योग्य दो स्कू खोल दें।

4



नीचे की ओर खींचकर हैंडल/लॉक ब्लॉक को हटा दें।

5



नया हैंडल/लॉक स्थापित करें।

6



यह सुनिश्चित करें कि इसे खोल के ऊपर ऊंचे स्थान पर बंद कर दिया जाए

7



सभी स्कू को वापस अपनी जगह पर रख दें + लाइनिंग को पकड़े हुए 2 छोटे क्लिप।

8



अंत में, सूटकेस की लाइनिंग और फिर जिप को बंद कर दें।

बाहरी ट्रॉली प्रणाली का प्रतिस्थापन - 5 मिनट

आवश्यक उपकरण

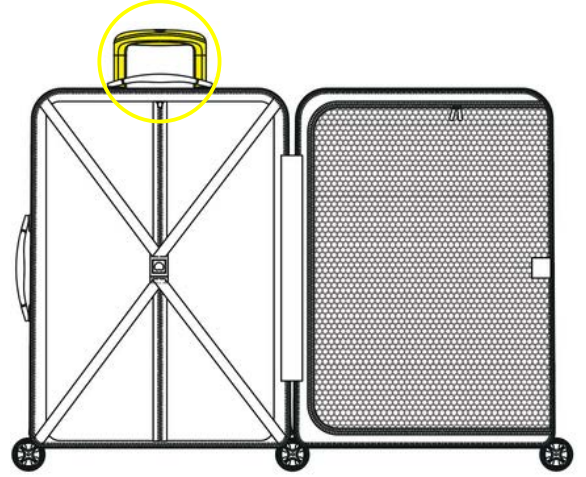

1



इसे निकालना आसान बनाने के लिए ट्रॉली सिस्टम को पहले पायदान पर समायोजित करें।

2



अपने सूटकेस को पूरी तरह से खोलें और इसे फर्श पर आधा फैला दें, यह सुनिश्चित करते हुए कि दोनों डिब्बे समतल हों...

... अस्तर तक आसान पहुंच के लिए।

DELSEY PARIS

1946

3



शीर्ष पेंच हटा दें

4



नीचे के पेंच हटा दें.

5



सभी मूल पेंच और हिस्से रखें।

6



भाग को बाहर से हटा दें और नए भाग को विपरीत दिशा में (अंदर से) पुनः जोड़ें।

7



अंत में, सूटकेस की लाइनिंग और फिर जिप को बंद कर दें।

एकीकृत का प्रतिस्थापन ट्रॉली प्रणाली - 7 मिनट

आवश्यक उपकरण



1

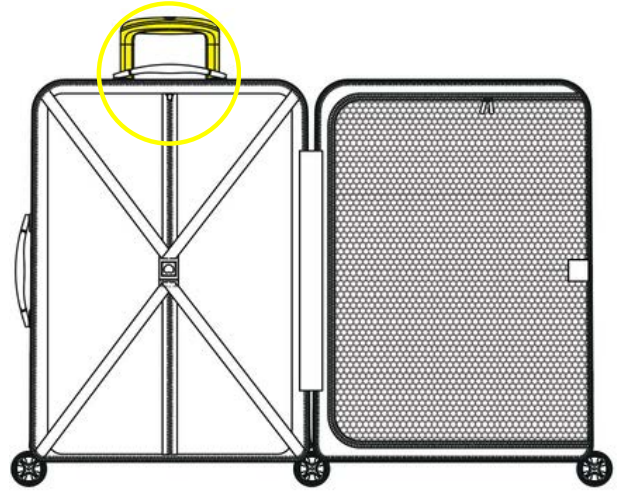

अपने सूटकेस को पूरी तरह से खोलें और इसे आधे में खोलें, यह सुनिश्चित करते हुए कि अस्तर तक आसान पहुंच के लिए दोनों डिब्बे सपाट हैं।

2



ट्रॉली सिस्टम को पकड़ने वाले ऊपर और नीचे के स्क्रू को खोल दें।

3



नए ट्रॉली सिस्टम को प्लाईवुड से सुरक्षित करके स्थापित करें हटाए गए पेंच.

4



समाप्त करने के लिए अस्तर को बंद करें और फिर अपना सामान।

एक हैंडल का प्रतिस्थापन - 4 मिनट

आवश्यक उपकरण



एक निश्चित हैंडल का उदाहरण

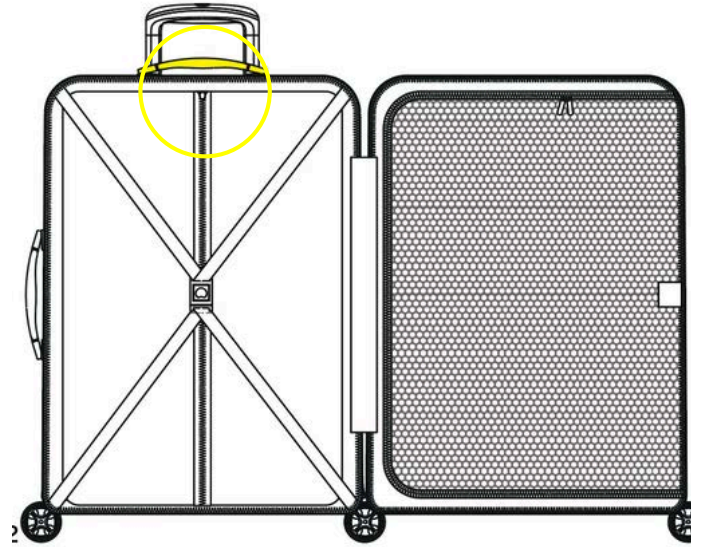

1



अपने सूटकेस को पूरी तरह से खोलें और इसे फर्श पर आधा फैलाएं, यह सुनिश्चित करते हुए कि दोनों तरफ सपाट रहें।



...अस्तर तक आसान पहुंच के लिए।

2



हैंडल को पकड़े हुए स्कू को खोल दें (स्कू हेड संभवतः सुरक्षात्मक टेप से छिपा हुआ है)।

3



4



हैंडल को बाहर से हटा दें और नया हिस्सा अंदर लगा दें विपरीत दिशा (अंदर से)। फिर सभी पेंच लगाएं कस कर वापस अपनी जगह पर।

अंत में, पहले अस्तर और फिर सूटकेस की ज़िप बंद कर दें।

स्लाइडर पुल का प्रतिस्थापन - 7 मिनट

आवश्यक उपकरण

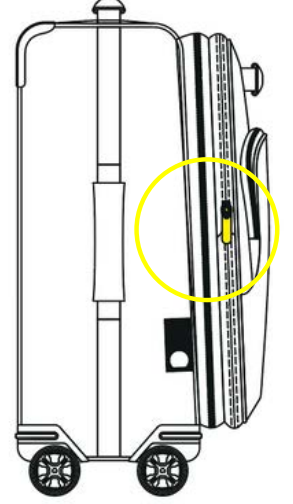

1



क्षतिग्रस्त जिपर को वायर कटर या फोल्डर से काटें, ध्यान रखें कि स्लाइडरब्रिज को नुकसान न पहुंचे।

2



एक फ्लैट हेड स्कूड्राइवर के साथ स्लाइडर ब्रिज को धीरे से 1 या 2 मिमी ऊपर उठाएं ताकि नया जिपर पुलर फिट किया जा सके।

3



हाथ से पहले भाग की दिशा की जांच करें: दाएं या बाएं। सरौता की एक जोड़ी का उपयोग करके स्लाइडर ब्रिज को बंद करें (पुल को खरोंचने से बचाने के लिए सरौता के दांतों को मोटे टेप से सुरक्षित रखें)।

ओवरवेट संकेतक हैंडल पर बैटरियों का प्रतिस्थापन - 3 मिनट

आवश्यक उपकरण

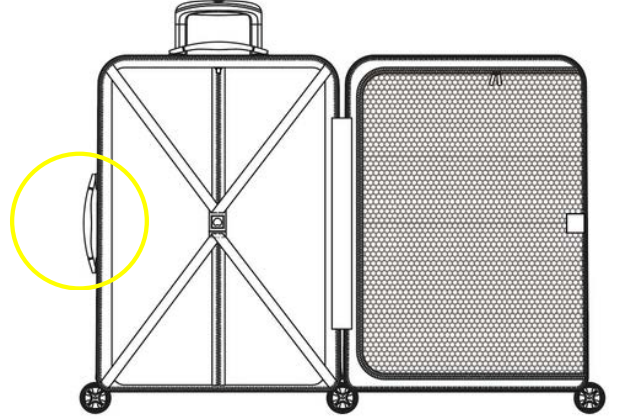

अपने सूटकेस को पूरी तरह से खोलें, और इसे फर्श पर आधा फैलाएं, यह सुनिश्चित करते हुए कि दोनों डिब्बे सपाट हैं...



... अस्तर तक आसान पहुंच के लिए।

2



हैंडल प्लाइवुड तक सीधी पहुंच की अनुमति देने के लिए आंतरिक अस्तर को सावधानीपूर्वक खोलें, और सावधान रहें कि सामग्री या आसपास के सीम को नुकसान न पहुंचे

DELSEY PARIS

1946



हैंडल के पीछे, एक छोटी एकीकृत हैच बैटरी डिब्बे तक आसान पहुंच प्रदान करती है।



हैंडल के पीछे स्थित इस छोटे हैच को सावधानीपूर्वक खोलें और संकेतित ध्रुवता (+/-) का सम्मान करते हुए, उपयोग की गई दो बटन बैटरियों को नई बैटरियों से बदलें।



अंत में, छोटी हैच के फ्लैप को बंद करें, आपको एक "क्लिक" सुनाई देनी चाहिए। सूटकेस की लाइनिंग और फिर ज़िप बंद कर दें।

சுருக்கம்

நீங்கள் செய்ய விரும்பும் பழுதுபார்க்கும் வகையை கிளிக் செய்யவும்:

1. ஒரு காஸ்டர் சக்கரத்தை மாற்றுதல்
2. ஒரு கூட்டுப் பூட்டை மாற்றுதல்
3. ஒரு கூட்டுப் பூட்டை மாற்றுதல்
கேஸ் மான்சி
4. வெளிப்புற தள்ளுவண்டி அமைப்பின் மாற்றீடு
5. ஒருங்கிணைக்கப்பட்டதை மாற்றுதல்
தள்ளுவண்டி அமைப்பு
6. ஒரு கைப்பிடியின் மாற்றீடு
7. ஒரு ஸ்டைலர் இழுவை மாற்றுதல்
8. அதிக எடை காட்டி கைப்பிடியில்
பேட்டரிகளை மாற்றுதல்

அகராதி

தேவையான கருவிகள்

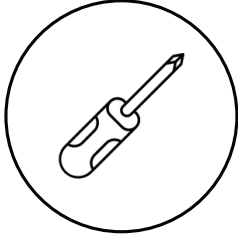

ஸ்க்ரூட்ரைவர்
சிலுவை வடிவம்



இடுக்கி வெட்டுதல்

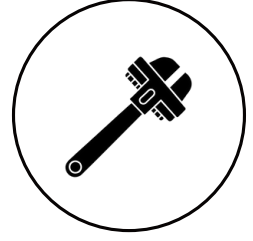

இடுக்கி பவர்
ஸ்ட்ரிப்



கந்தல்



ஸ்க்ரூடிரைவர்
பிளாட்

மறுப்பு

இந்த DIY பழுதுபார்க்கும் கருவி அல்லது இந்த வழிமுறைகளால் ஏற்படும் காயம் அல்லது சேதங்களுக்கு DELSEY PARIS பொறுப்பேற்காது, எனவே தயவுசெய்து எச்சரிக்கையுடன் தொடரவும். இந்த வழிமுறைகள் குறித்து ஏதேனும் கேள்விகள் இருந்தால், பழுதுபார்க்கும் செயல்முறையின் எந்த நிலையிலும் நீங்கள் எப்போதும் வாடிக்கையாளர் சேவையைத் தொடர்பு கொள்ளலாம், நாங்கள் அதைச் சமாளிக்க உங்களுக்கு உதவுவோம்!

ஒரு காஸ்டர் சக்கரத்தை மாற்றுதல் 4 நிமிடங்கள்

தேவையான கருவிகள்



சக்கர அசெம்பிளியின் உதாரணம்

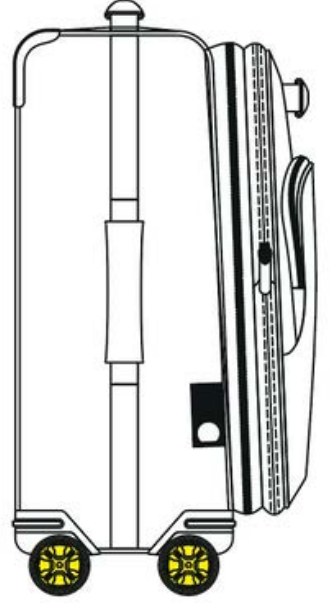

1



தயவு செய்து உங்கள் சூட்கேஸை முழுவதும் திறந்து தரையில் பாதியாக விரிக்கவும், இரண்டு பெட்டிகளும் தட்டையாக இருப்பதை உறுதி செய்யவும்...



... லைனிங்கிற்கு எளிதாக அணுக அனுமதிக்க.

2



பின்னர் சக்கரத்திலிருந்து தக்கவைக்கும் திருகு (களை) அகற்றவும்.

3



சக்கரத்தை அகற்றி, புதிய பகுதியை எதிர்திசையில் (உள்ளே இருந்து) இணைக்கவும் மற்றும் அனைத்து திருகுகளையும் மீண்டும் இடத்தில் இறுக்கவும்.

4



இறுதியாக, புறணி மற்றும் சாமான்களை மூடு.

ஒரு கூட்டுப் பூட்டை மாற்றுதல் 3 நிமிடங்கள்

தேவையான கருவிகள்



லாக் அசெம்பிளியின் உதாரணம்...

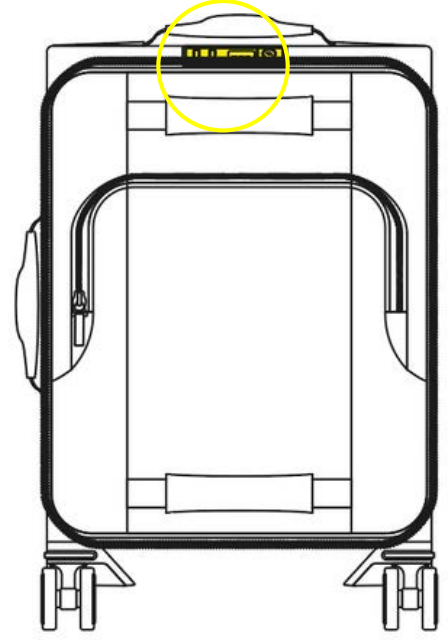

1



உங்கள் சூட்கேஸை முழுவதுமாக திறந்து தரையில் பாதியாக விரித்து, இரண்டு பெட்டிகளும் தட்டையாக இருப்பதை உறுதி செய்யவும்.



லைனிங்கை எளிதாக அணுக அனுமதிக்க.

2



லைனரின் கீழ் ஃபாஸ்டென்சரின் ஒட்டு பலகையை அணுகவும் (திருகு தலைகள் இடமாற்றம் ஆபத்தைத் தவிர்க்க பேப்பின் கீழ் பாதுகாக்கப்பட வேண்டும்).



ஒட்டு பலகையில் இருந்து திருகுகளை அகற்றவும்.

3



சேதமடைந்த பூட்டை அகற்றவும். பூட்டு அகற்றப்பட்டதும், பிரித்தெடுத்தலின் எதிர் திசையில் உள்ளே இருந்து திருகுகளை திருகுவதன் மூலம் புதிய பூட்டை சரிசெய்யவும். கவுண்டர் பிளேட்டை மாற்றவும் (டூள்ளி 2 இல் திருகப்பட்டது).

4



இறுதியாக, புறணி மற்றும் சாமான்களை மூடு

ஒரு கூட்டுப் பூட்டை மாற்றுதல் கேஸ் மான்சி - 10 நிமிடங்கள்

தேவையான கருவிகள்



உங்கள் சூட்கேஸை முழுவதுமாக திறந்து தரையில் பாதியாக விரித்து, இரண்டு பெட்டிகளும் தட்டையாக இருப்பதை உறுதி செய்து கொள்ளுங்கள்...

பூட்டின் ஒவ்வொரு பக்கத்திலும் 1 சிறிய பிளாஸ்டிக் துண்டால் வைக்கப்பட்டுள்ள லைனரை அவிழ்த்து விடுங்கள்.



லைனரைத் திறந்து, பூட்டின் பின்புறத்தில் கீழே உள்ள 2 திருகுகளை அவிழ்த்து விடுங்கள்.

இப்போது அணுகக்கூடிய 2 திருகுகளை அவிழ்த்து விடுங்கள்.

4



கீழ்நோக்கி இழுப்பதன் மூலம் கைப்பிடி/ பூட்டுத்தொகுதியை அகற்றவும்.

5



புதிய கைப்பிடி/பூட்டை நிறுவவும்.

6



ஷெல்லுக்கு எதிராக அதை பூட்டுவதை உறுதிசெய்க

7

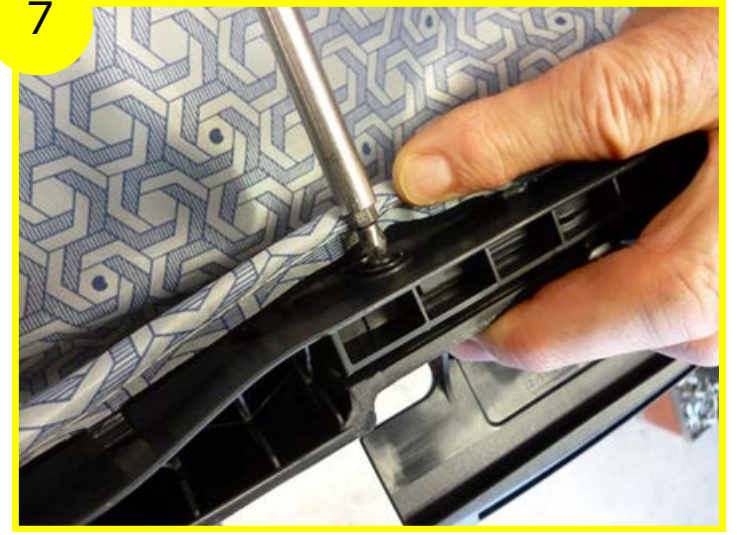

அனைத்து திருகுகளையும் மீண்டும் இடத்தில் வைக்கவும் + லைனிங்கை வைத்திருக்கும் 2 சிறிய கிளிப்புகள்

8



இறுதியாக, சூட்கேஸின் ஜிப்பை மூடவும்.

வெளிப்புற தள்ளுவண்டி அமைப்பின் மாற்றீடு - 5 நிமிடங்கள்

தேவையான கருவிகள்



1

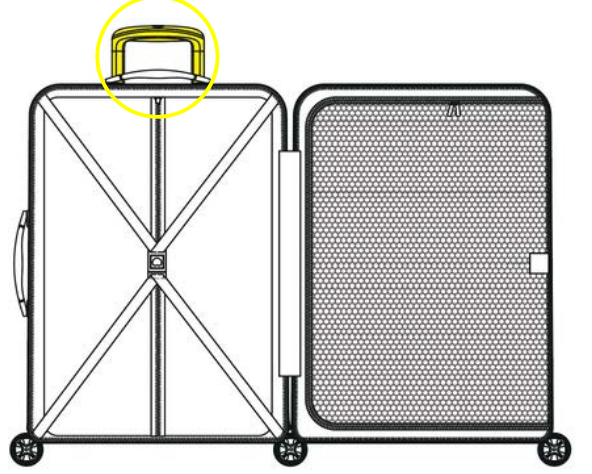

பிரித்தெடுப்பதை எளிதாக்க, டிராலி அமைப்பை முதல் நாட்சுக்கு சரிசெய்யவும்.

2



உங்கள் சூட்கேஸை முழுவதுமாக திறந்து தரையில் பாதியாக விரித்து, இரண்டு பெட்டிகளும் தட்டையாக இருப்பதை உறுதி செய்து கொள்ளுங்கள்.

.. லைனிங்கை எளிதாக அணுகுவதற்கு.

DELSEY PARIS

1946

3



மேல் திருகுகளை அகற்றவும்

4



கீழே உள்ள திருகுகளை அகற்றவும்.

5



அனைத்து அசல் திருகுகள் மற்றும் பாகங்கள் வைத்து.

6



வெளியில் இருந்து பகுதியை அகற்றி, புதிய பகுதியை எதிர் திசையில் (உள்ளே இருந்து) மீண்டும் இணைக்கவும்.

7



இறுதியாக, சூட்கேஸின் ஜிப்பை மூடவும்.

ஒருங்கிணைக்கப்பட்டதை மாற்றுதல்
தள்ளுவண்டி அமைப்பு - 7 நிமிடங்கள்

தேவையான கருவிகள்



1

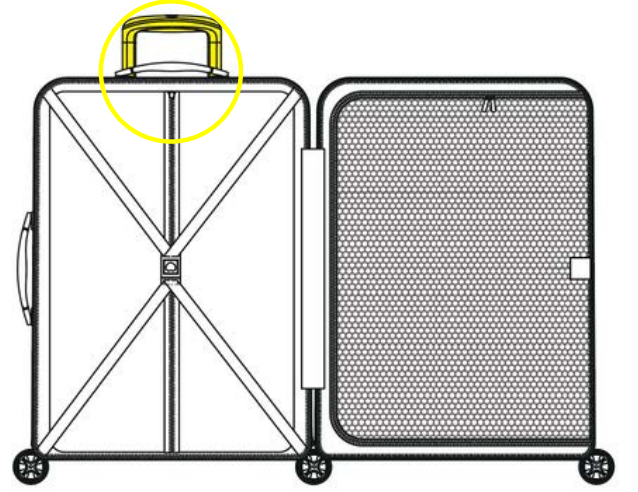

உங்கள் சூட்கேஸை முழுவதுமாக திறந்து பாதியாக விரித்து, லைனிங்கை எளிதாக அணுக, இரண்டு பெட்டிகளும் தட்டையாக இருப்பதை உறுதிசெய்து கொள்ளவும்.

2



தள்ளுவண்டி அமைப்பை வைத்திருக்கும் மேல் மற்றும் கீழ் திருகுகளை அவிழ்த்து விடுங்கள்.

DELSEY PARIS

1946

3



ப்ளைவுட் மூலம் பாதுகாப்பதன் மூலம் புதிய தள்ளுவண்டி அமைப்பை நிறுவவும் அகற்றப்பட்ட திருகுகள்.

4



புறணியை மூடவும், பின்னர் உங்கள் சாமான்களை மூடவும்.

ஒரு கைப்பிடியின் மாற்றீடு - 4 நிமிடங்கள்

தேவையான கருவிகள் 

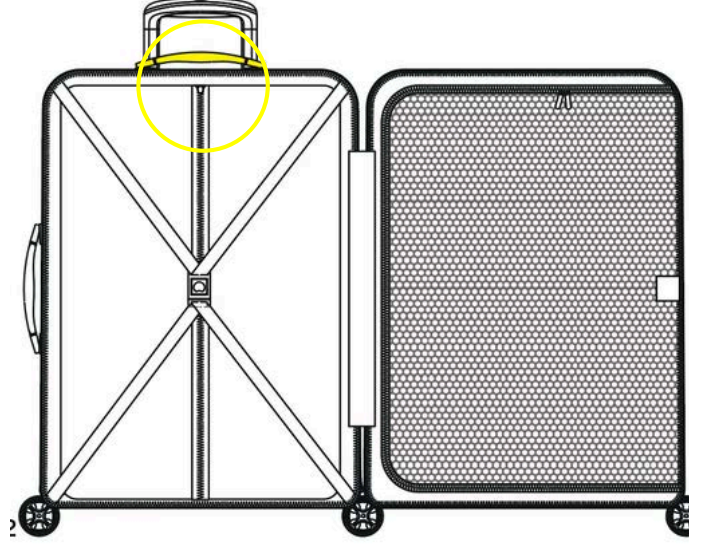

நிலையான கைப்பிடியின் எடுத்துக்காட்டு



உங்கள் சூட்கேஸை முழுவதுமாகத் திறந்து, அதை தரையில் பாதியாக விரித்து, இருபுறமும் தட்டையாக இருப்பதை உறுதிசெய்யவும்.

லைனிங்கை எளிதாக அணுகுவதற்கு.

2



கைப்பிடியை வைத்திருக்கும் திருகுகளை அவிழ்த்து விடுங்கள் (திருகு தலை ஒருவேளை பாதுகாப்பு நாடா மூலம் மறைக்கப்படலாம்).

3



4



வெளியில் இருந்து கைப்பிடியை அகற்றி புதிய பகுதியை இணைக்கவும் எதிர் திசையில் (உள்ளே இருந்து). பின்னர் அனைத்து திருகுகளையும் வைக்கவும் இறுக்குவதன் மூலம் மீண்டும் இடத்தில்.

இறுதியாக, லைனிங்கை மூடிவிட்டு சூட்கேஸ் ரிவிட் செய்யவும்.

ஒரு ஸ்லைடர் இழுவை மாற்றுதல் - 7 நிமிடங்கள்

தேவையான கருவிகள்



1

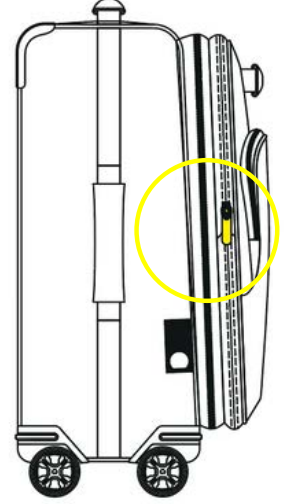

ஸ்லைடர்பிரிட்ஜை சேதப்படுத்தாமல் பார்த்துக்கொண்டு, சேதமடைந்த ஜிப்பரை கம்பி கட்டர்கள் அல்லது கோப்புறைகள் மூலம் வெட்டுங்கள்.

2



ஒரு பிளாட் ஹெட் ஸ்க்ரூடிரைவர் மூலம் ஸ்லைடர் பிரிட்ஜை 1 அல்லது 2 மிமீ மெதுவாக உயர்த்தவும், அதனால் புதிய ஜிப்பர் புல்லர் பொருத்தப்படும்.

3



முன் பகுதியின் திசையின் திசையை சரிபார்க்கவும்: வலது அல்லது இடது. ஒரு ஜோடி இடுக்கியைப் பயன்படுத்தி ஸ்லைடர் பிரிட்ஜை மூடு (பிரிட்ஜ் கீறாதபடி தடிமனான டேப்பைக் கொண்டு இடுக்கியின் பற்களைப் பாதுகாக்கவும்).

அதிக எடை காட்டி கைப்பிடியில் பேட்டரிகளை மாற்றுதல் - 3 நிமிடங்கள்

தேவையான கருவிகள்

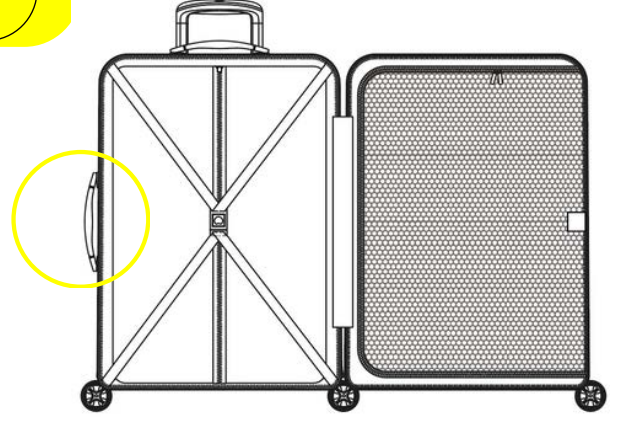

1
உங்கள் சூட்கேஸை முழுவதுமாகத் திறந்து, தரையில் பாதியாக விரித்து, இரண்டு பெட்டிகளும் தட்டையாக இருப்பதை உறுதி செய்து...



... லைனிங்கை எளிதாக அணுகுவதற்கு.



2
கைப்பிடி ஒட்டு பலகைக்கு நேரடி அணுகலை அனுமதிக்க உள் புறணியை கவனமாகத் திறந்து, பொருள் அல்லது சுற்றியுள்ள சீம்களை சேதப்படுத்தாமல் கவனமாக இருங்கள்.



கைப்பிடியின் பின்புறத்தில், ஒரு சிறிய ஒருங்கிணைந்த ஹட்ச் பேட்டரிகள் பெட்டிக்கு எளிதாக அணுகலை வழங்குகிறது.



கைப்பிடியின் பின்புறத்தில் அமைந்துள்ள இந்த சிறிய ஹட்ச்சைக் கவனமாகத் திறந்து, பயன்படுத்திய இரண்டு பொத்தான் பேட்டரிகளை புதியவற்றுடன் மாற்றவும், சுட்டிக்காட்டப்பட்ட துருவமுனைப்பை (+/-) மதிக்க வேண்டும் என்பதை உறுதிப்படுத்தவும்.



இறுதியாக, சிறிய ஹட்சின் மடலை மூடு, நீங்கள் ஒரு "கிளிக்" கேட்க வேண்டும். லைனிங் மற்றும் பின் சூட்கேஸின் ஜிப்பை மூடு.

المحتويات

انقر على نوع الإصلاح الذي تريد القيام به:

1. استبدال عجلة العجلات
2. استبدال القفل المجمع
3. استبدال القفل المجمع قضية مونسي
4. استبدال نظام الترولي الخارجي
5. استبدال المتكاملة نظام الترولي
6. استبدال المقبض
7. استبدال سحب المنزلق
8. استبدال البطاريات بمقبض مؤشر الوزن الزائد

الأدوات المطلوبة

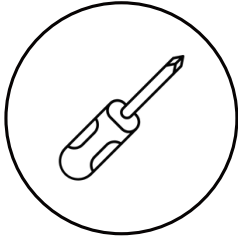

مفك صليبي



قطع كماشة

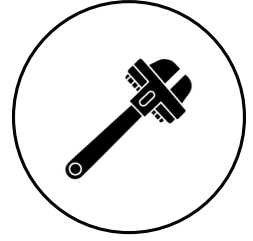

كماشة قطاع الطاقة



خرقة



مفك البراغي مسطح

إخلاء المسؤولية

لا تتحمل DELSEY PARIS أي مسؤولية عن الإصابات أو الأضرار الناتجة عن مجموعة أدوات الإصلاح هذه أو هذه التعليمات، لذا يُرجى المتابعة بحذر. إذا كانت لديك أي أسئلة حول هذه التعليمات، يمكنك دائمًا التواصل مع خدمة العملاء 289 في أي مرحلة من مراحل عملية الإصلاح وسنساعدك في ذلك!

استبدال عجلة العجلات 4 دقائق

الأدوات المطلوبة

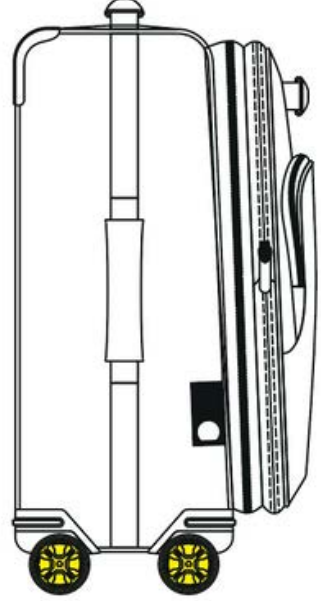

مثال على تجميع العجلة

1



يرجى فتح حقيبتك بالكامل وفتحها إلى
نصفين على الأرض، مع التأكد من أن
المقصورتين مسطحتان...

... للسماح بسهولة الوصول إلى البطانة.

2



ثم قم بإزالة براغي (مسامير) التثبيت من العجلة.

3



قم بإزالة العجلة وقم بتثبيت الجزء الجديد في الاتجاه المعاكس (من الداخل) وأحكم ربط جميع البراغي مرة أخرى في مكانها.

4



وأخيرا، أغلق البطانة والأمتعة.

استبدال القفل المجمع 3 دقائق

الأدوات المطلوبة

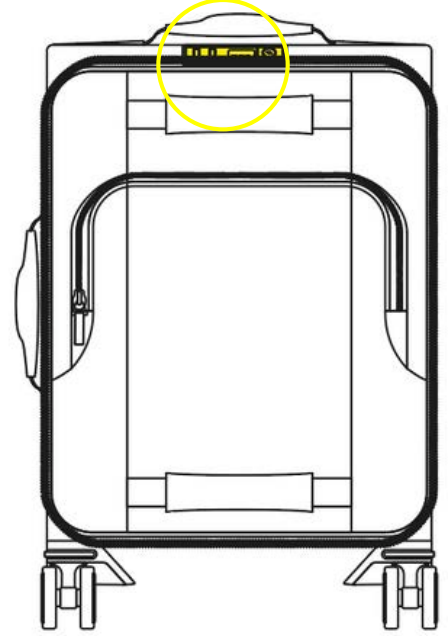

مثال على تجميع القفل...

1



افتح حقيبتك بالكامل وافرداها إلى نصفين على الأرض، مع التأكد من أن المقصورتين مسطحتان.

...للسماح بالوصول السهل إلى البطانة.

2



قم بالوصول إلى الخشب الرقائقي الخاص بأداة التثبيت أسفل البطانة (يجب حماية رؤوس البراغي تحت الشريط لتجنب خطر الخلع).



قم بإزالة المسامير من الخشب الرقائقي.

3



قم بإزالة القفل التالف. بمجرد إزالة القفل، قم بتثبيت القفل الجديد عن طريق ربط البراغي في الاتجاه المعاكس للاستخراج (من الداخل). أعد وضع لوحة العداد (مفككة عند النقطة 2).

4



وأخيرًا، أغلق البطانة والأمتعة.

ستبدال القفل المجمع قضية مونسي

10 دقائق

الأدوات المطلوبة



1



افتح حقيبتك بالكامل وافردتها إلى نصفين على الأرض، مع التأكد من أن الجزأين مسطحان...



قم بفك البطانة المثبتة في مكانها بقطعة بلاستيكية صغيرة على كل جانب من القفل.

2



افتح البطانة، وقم بفك المسمارين الموجودين بالأسفل في الجزء الخلفي من القفل.

3



قم بفك المسمارين اللذين يمكن الوصول إليهما الآن.

4



قم بإزالة كتلة المقبض/القفل عن طريق سحبها للأسفل.

5



قم بتثبيت المقبض/القفل الجديد.

6



تأكد من قفله عالياً مقابل الصدفه

7



أعد جميع البراغي إلى مكانها + المشبكين الصغيرين اللذين يحملان البطانة.

8



وأخيراً، أغلقي البطانة ثم سحاب الحقيبه.

استبدال نظام الترولي الخارجي 5 دقائق

الأدوات المطلوبة

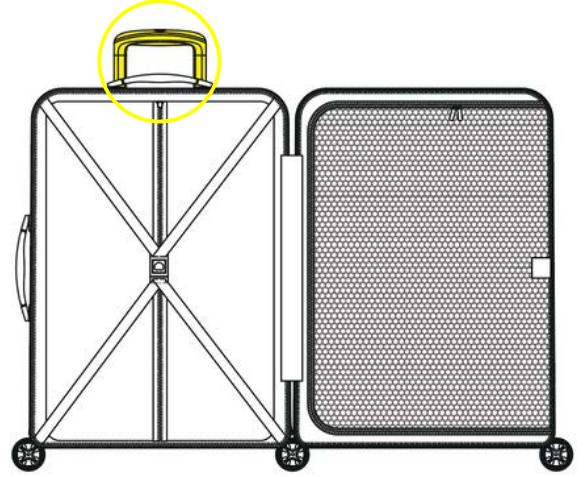

1



اضبط نظام العربة على الدرجة الأولى لتسهيل عملية الاستخراج.

2



...لسهولة الوصول إلى البطانة.

افتح حقيبتك بالكامل وافرد لها إلى نصفين على الأرض، وتأكد من أن كلا الحجرتين مسطحتان...

3



قم بإزالة المسامير العلوية

4



قم بإزالة المسامير السفلية.

5



احتفظ بجميع البراغي والأجزاء الأصلية.

6



قم بإزالة الجزء من الخارج وأعد تجميع الجزء الجديد في الاتجاه المعاكس (من الداخل).

7



وأخيرًا، أغلقي البطانة ثم سحب الحقيبة.

استبدال المتكاملة نظام الترولي 7 دقائق

الأدوات المطلوبة

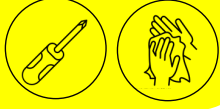

1

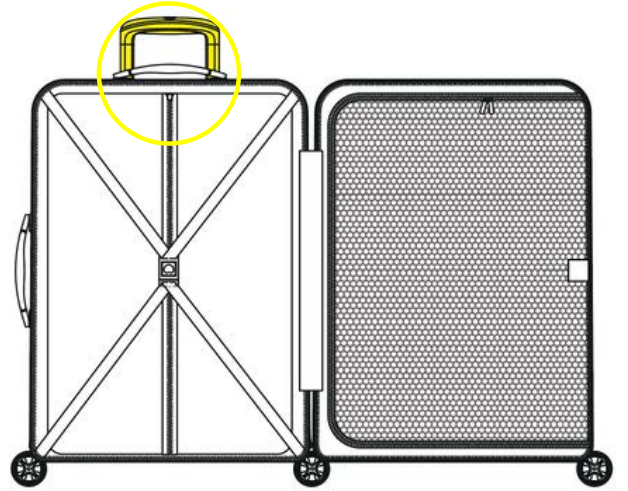

افتح حقيبتك بالكامل وافرداها إلى نصفين، مع التأكد من أن المقصورتين مسطحتان،
لسهولة الوصول إلى البطانة.

2

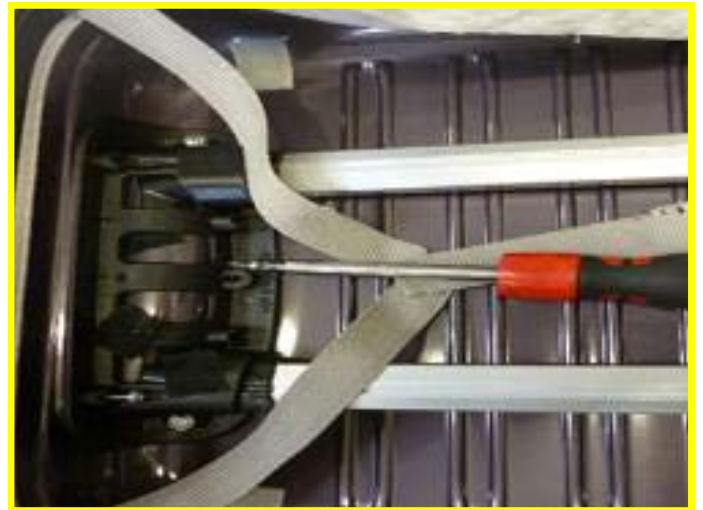

..قم بفك البراغي العلوية والسفلية التي تثبت نظام العربة

3



4



قم بتركيب نظام العربة الجديد، مع تأمينه باستخدام اللوح المضاد والبراغي التي قمت بإزالتها.

لإنهاء إغلاق البطانة ثم أمتعتك.

استبدال المقبض 4 دقائق

الأدوات المطلوبة

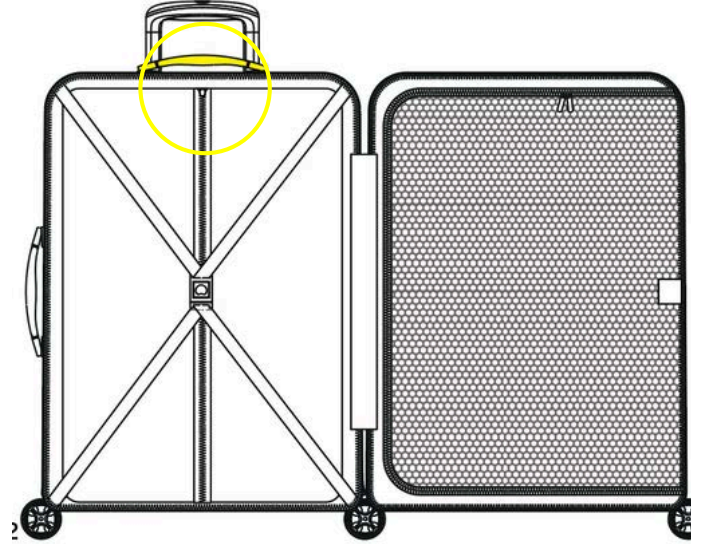

مثال على المقبض الثابت

1



...لسهولة الوصول إلى البطانة.

افتح حقيبتك بالكامل وافردھا إلى نصفين
على الأرض، مع التأكد من وضع كلا الجانبين
بشكل مسطح.

2



قم بفك البراغي التي تحمل المقبض (ربما يكون رأس المسمار مخفيًا بشريط واقٍ).

3



4



قم بإزالة المقبض من الخارج ثم قم بإرفاق الجزء الجديد به الاتجاه المعاكس (من الداخل). ثم ضع كل المسامير العودة إلى مكانها عن طريق تشديد.

وأخيرا، أغلق البطانة ثم سحب الحقيبة.

استبدال سحب المنزلق دقائق 7

الأدوات المطلوبة

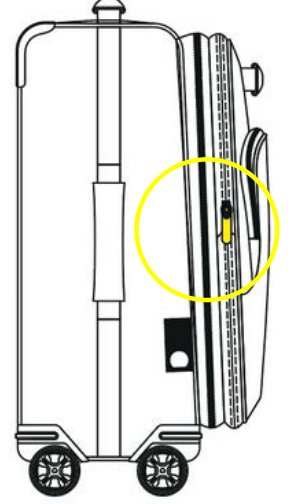

1



قم بقطع السحاب التالف باستخدام قاطعات الأسلاك أو
المجلدات، مع الحرص على عدم إتلاف الجسر المنزلق.

2



ارفع الجسر المنزلق بلطف بمقدار 1 أو 2 مم باستخدام مفك براغي مسطح الرأس حتى
يمكن تركيب صاحب السحاب الجديد.

3



تأكد من اتجاه اتجاه الجزء قبل اليد: اليمين أو اليسار. أغلق الجسر المنزلق باستخدام زوج من الكماشات (قم بحماية أسنان الكماشات بشريط سميك حتى لا تخدش الجسر).

استبدال البطاريات بمقبض مؤشر الوزن الزائد دقائق 3

الأدوات المطلوبة

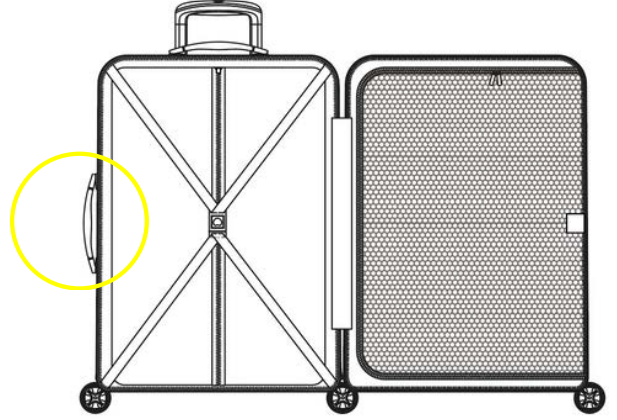

1



افتح حقيبتك بالكامل، ثم افردّها إلى نصفين على الأرض، مع التأكد من أن المقصورتين مسطحتان...



...لسهولة الوصول إلى البطانة.

2



افتح البطانة الداخلية بعناية للسماح بالوصول المباشر إلى الخشب الرقائقي للمقبض، واحرص على عدم إتلاف المواد أو الطبقات المحيطة



يوجد في الجزء الخلفي من المقبض فتحة صغيرة مدمجة توفر سهولة الوصول إلى حجرة البطاريات.



افتح هذه الفتحة الصغيرة الموجودة في الجزء الخلفي من المقبض بعناية واستبدل بطاريتي الزر المستخدمتين بأخرى جديدة، مع التأكد من احترام القطبية المشار إليها (-/+).



أخيرًا، أغلق باب الفتحة الصغيرة، ويجب أن تسمع "نقرة". أغلق البطانة ثم سحاب الحقيبة.

περίληψη

Κάντε κλικ στον τύπο επισκευής που θέλετε να κάνετε:

1. ΑΝΤΙΚΑΤΑΣΤΑΣΗ ΡΟΔΑΣ
2. ΑΝΤΙΚΑΤΑΣΤΑΣΗ ΚΛΕΙΔΑΡΙΑΣ ΣΥΝΔΥΑΣΜΟΥ
3. ΑΝΤΙΚΑΤΑΣΤΑΣΗ ΚΛΕΙΔΑΡΙΑΣ ΣΥΝΔΥΑΣΜΟΥ CASE MONCEY
4. ΑΝΤΙΚΑΤΑΣΤΑΣΗ ΕΞΩΤΕΡΙΚΟΥ ΣΥΣΤΗΜΑΤΟΣ ΤΡΟΛΕΪ
5. ΑΝΤΙΚΑΤΑΣΤΑΣΗ ΤΟΥ ΟΛΟΚΛΗΡΩΜΕΝΟΥ ΣΥΣΤΗΜΑ ΤΡΟΛΕΪ
6. ΑΝΤΙΚΑΤΑΣΤΑΣΗ ΛΑΒΗΣ
7. ΑΝΤΙΚΑΤΑΣΤΑΣΗ ΤΟΥ ΜΟΧΛΟΥ ΣΥΡΟΜΕΝΟΥ ΜΗΧΑΝΙΣΜΟΥ (ΣΥΡΤΗΣ)
8. ΑΝΤΙΚΑΤΑΣΤΑΣΗ ΤΩΝ ΜΠΑΤΑΡΙΩΝ ΣΤΗ ΛΑΒΗ ΤΟΥ ΔΕΪΚΤΗ ΥΠΕΡΒΟΛΙΚΟΥ ΒΑΡΟΥΣ

Απαιτούμενα εργαλεία

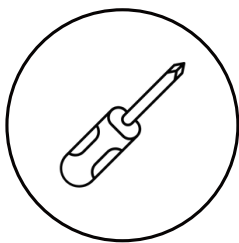

Σταυροκατσάβιδο



Κοπή πένσας

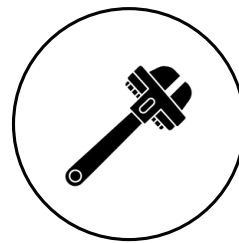

Πένσα για ταινία ρεύματος



Πανί

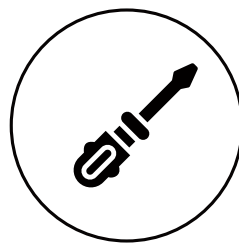

Κατσαβίδι επίπεδο

ΑΠΟΠΟΙΗΣΗ ΕΥΘΥΝΗΣ

Η DELSEY PARIS δεν αναλαμβάνει καμία ευθύνη για τραυματισμούς ή ζημιές που προκύπτουν από αυτό το σετ επισκευής DIY ή τις παρούσες οδηγίες, γι' αυτό προχωρήστε με προσοχή. Εάν έχετε οποιοσδήποτε απορίες σχετικά με αυτές τις οδηγίες, μπορείτε πάντα να απευθυνθείτε στην εξυπηρέτηση πελατών σε οποιοδήποτε στάδιο της διαδικασίας επισκευής και θα σας βοηθήσουμε!

ΑΝΤΙΚΑΤΑΣΤΑΣΗ ΡΟΔΑΣ 4 ΛΕΠΤΑ

ΑΠΑΙΤΟΥΜΕΝΑ ΕΡΓΑΛΕΙΑ



Παράδειγμα συναρμολόγησης τροχού

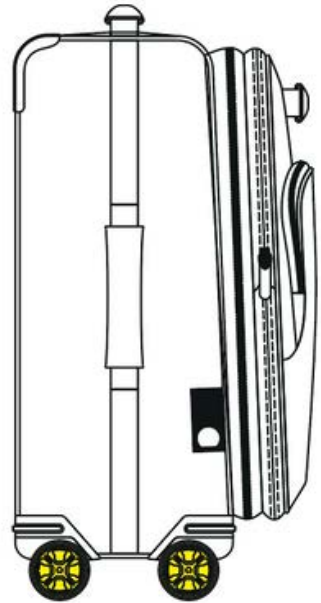

1



Ανοίξτε τη βαλίτσα σας πλήρως και ξεδιπλώστε τη στη μέση στο πάτωμα, διασφαλίζοντας ότι οι δύο θήκες είναι επίπεδες...

... για εύκολη πρόσβαση στην επένδυση.

2



Στη συνέχεια αφαιρέστε τη(τις) βίδα(ες) συγκράτησης από τον τροχό.

3



Αφαιρέστε τον τροχό και συνδέστε το νέο μέρος προς την αντίθετη κατεύθυνση (από μέσα) και σφίξτε όλες τις βίδες ξανά στη θέση τους.

4



Τέλος, κλείστε την επένδυση και την αποσκευές.

ΑΝΤΙΚΑΤΑΣΤΑΣΗ ΚΛΕΙΔΑΡΙΑΣ ΣΥΝΔΥΑΣΜΟΥ

3 ΛΕΠΤ΄Α

ΑΠΑΙΤΟΥΜΕΝΑ ΕΡΓΑΛΕΪΑ

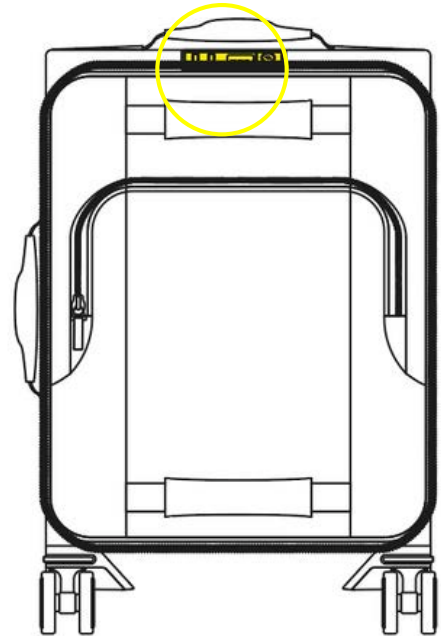

Παράδειγμα συναρμολόγησης κλειδαριάς...

1



Ανοίξτε πλήρως τη βαλίτσα σας και ξεδιπλώστε τη στη μέση στο πάτωμα, διασφαλίζοντας ότι οι δύο θήκες είναι επίπεδες.

...για εύκολη πρόσβαση στην επένδυση.

2



Πρόσβαση στο κόντρα πλακέ του συνδετήρα κάτω από το επένδυμα (οι κεφαλές των βιδών θα πρέπει να προστατεύονται με ταινία για να αποφευχθεί ο κίνδυνος αποκόλλησης).



Αφαιρέστε τις βίδες από το κόντρα πλακέ.

3



Αφαιρέστε την κατεστραμμένη κλειδαριά. Μόλις αφαιρεθεί η κλειδαριά, στερεώστε τη νέα κλειδαριά βιδώνοντας τις βίδες στην αντίθετη κατεύθυνση εξαγωγής (από το εσωτερικό). Επανατοποθετήστε την πλάκα του πάγκου (ξεβιδωμένη στο σημείο 2).

4



Και τέλος, κλείστε την επένδυση και την αποσκευη

ΑΝΤΙΚΑΤΑΣΤΑΣΗ ΚΛΕΙΔΑΡΙΑΣ ΣΥΝΔΥΑΣΜΟΥ CASE MONCEY - 10 ΛΕΠΤΑ

ΑΠΑΙΤΟΥΜΕΝΑ ΕΡΓΑΛΕΙΑ



1



Ανοίξτε τη βαλίτσα σας εντελώς και ξεδιπλώστε τη στη μέση στο πάτωμα, φροντίζοντας οι δύο θήκες να είναι επίπεδες...



Ξεκουμπώστε την επένδυση που συγκρατείται στη θέση της με 1 μικρό πλαστικό κομμάτι σε κάθε πλευρά της κλειδαριάς.

2



Ανοίξτε την επένδυση, ξεβιδώστε τις 2 βίδες από κάτω στο πίσω μέρος της κλειδαριάς.

3



Ξεβιδώστε τις 2 βίδες που είναι πλέον προσβάσιμες.

4



Αφαιρέστε το μπλοκ λαβής/ασφάλισης τραβώντας προς τα κάτω.

5



Τοποθετήστε τη νέα λαβή/κλείδωμα.

6



Φροντίστε να το κλειδώσετε ψηλά στο κέλυφος

7



Τοποθετήστε ξανά όλες τις βίδες στη θέση τους + τα 2 μικρά κλιπ που συγκρατούν την επένδυση.

8



Τέλος, κλείστε την επένδυση και μετά το φερμουάρ της βαλίτσας.

ΑΝΤΙΚΑΤΑΣΤΑΣΗ ΕΞΩΤΕΡΙΚΟΥ ΣΥΣΤΗΜΑΤΟΣ ΤΡΟΛΕΪ - 5 ΛΕΠΤΑ

ΑΠΑΙΤΟΥΜΕΝΑ ΕΡΓΑΛΕΙΑ

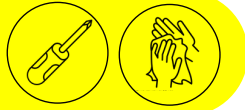

1

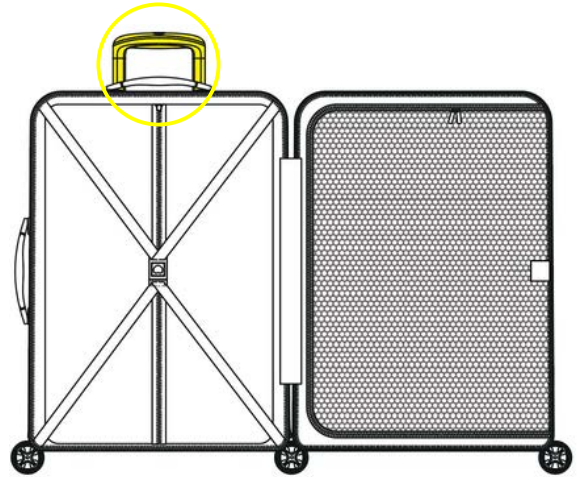

Ρυθμίστε το σύστημα τρόλεϊ στην πρώτη εγκοπή, για να διευκολύνετε την εξαγωγή.

2



Ανοίξτε τη βαλίτσα σας εντελώς και ξεδιπλώστε τη στη μέση στο πάτωμα, φροντίζοντας να είναι και οι δύο θήκες επίπεδες ...

... για εύκολη πρόσβαση στην επένδυση.

3



Αφαιρέστε τις επάνω βίδες

4



Αφαιρέστε τις κάτω βίδες.

5



Διατηρήστε όλες τις γνήσιες βίδες και εξαρτήματα.

6



Αφαιρέστε το εξάρτημα από το εξωτερικό και επανασυναρμολογήστε το νέο μέρος προς την αντίθετη κατεύθυνση (από μέσα).

7



Τέλος, κλείστε την επένδυση και μετά το φερμουάρ της βαλίτσας.

ΑΝΤΙΚΑΤΑΣΤΑΣΗ ΤΟΥ ΟΛΟΚΛΗΡΩΜΕΝΟΥ ΣΥΣΤΗΜΑ ΤΡΟΛΕΪ - 7 ΛΕΠΤΑ

ΑΠΑΙΤΟΥΜΕΝΑ ΕΡΓΑΛΕΙΑ



1

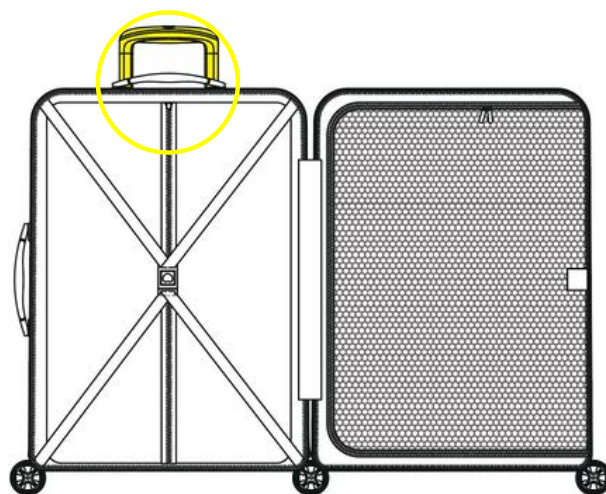

Ανοίξτε τελείως τη βαλίτσα σας και ξεδιπλώστε τη στη μέση, φροντίζοντας οι δύο θήκες να είναι επίπεδες, για εύκολη πρόσβαση στην επένδυση.

2



Ξεβιδώστε τις πάνω και κάτω βίδες που συγκρατούν το σύστημα τρολεϊ.

3



Εγκαταστήστε το νέο σύστημα τρόλιϊ στερεώνοντάς το με το κόντρα πλακέ και οι βίδες που αφαιρέθηκαν.

4



Για να τελειώσετε κλείστε την επένδυση και μετά τις αποσκευές σας.

ΑΝΤΙΚΑΤΑΣΤΑΣΗ ΛΑΒΗΣ - 4 λεπτά

OUTILS REQUIS



Παράδειγμα σταθερής λαβής

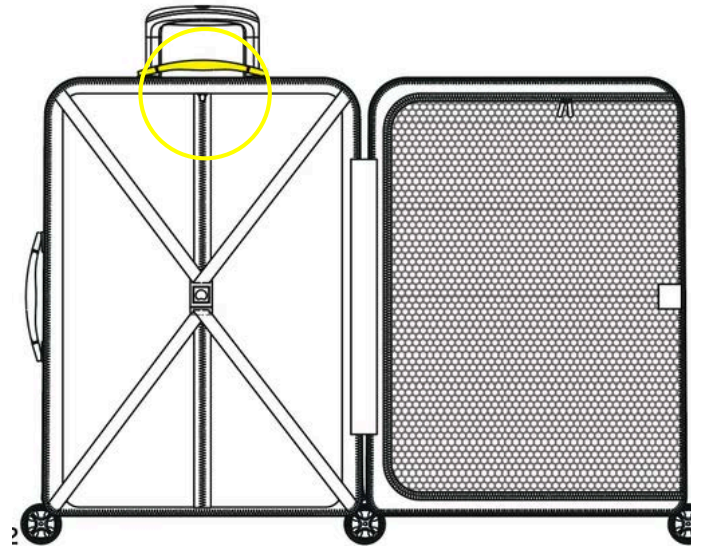

1



Ανοίξτε τελείως τη βαλίτσα σας και ξεδιπλώστε τη στη μέση στο πάτωμα, φροντίζοντας και οι δύο πλευρές να είναι επίπεδη.



...για εύκολη πρόσβαση στην επένδυση.

2



Ξεβιδώστε τις βίδες που συγκρατούν τη λαβή (η κεφαλή της βίδας πιθανόν να είναι κρυμμένη με προστατευτική ταινία).

3



4



Αφαιρέστε τη λαβή από το εξωτερικό και συνδέστε το νέο εξάρτημα μέσα αντίθετη φορά (από μέσα). Στη συνέχεια, βάλτε όλες τις βίδες πίσω στη θέση του σφίγγοντα.

Τέλος, κλείστε την επένδυση και μετά το φερμουάρ της βαλίτσας.

Αντικατάσταση του μοχλού συρόμενου μηχανισμού (σύρτης) - 7 λεπτά

ΑΠΑΙΤΟΥΜΕΝΑ ΕΡΓΑΛΕΙΑ



1

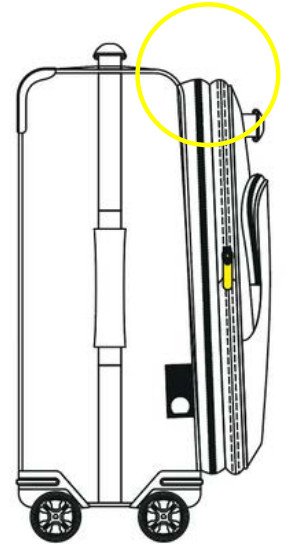

Κόψτε το κατεστραμμένο φερμουάρ με συρματοκόπτες ή φακέλους, προσέχοντας να μην προκαλέσετε ζημιά στη γέφυρα ολίσθησης.

2



Ανασηκώστε απαλά τη γέφυρα ολίσθησης κατά 1 ή 2 mm με ένα κατσαβίδι επίπεδης κεφαλής, ώστε να μπορεί να τοποθετηθεί το νέο εξολκέα με φερμουάρ.

3



Ελέγξτε την κατεύθυνση της κατεύθυνσης του εξαρτήματος πριν το χέρι: δεξιά ή αριστερά. Κλείστε τη γέφυρα ολίσθησης χρησιμοποιώντας μια πένσα (προστατέψτε τα δόντια της πένσας με χοντρή ταινία για να μην γρατσουνίσετε τη γέφυρα).

Αντικατάσταση των μπαταριών στη λαβή του δείκτη υπερβολικού βάρους - 3 λεπτά

ΑΠΑΙΤΟΥΜΕΝΑ ΕΡΓΑΛΕΙΑ

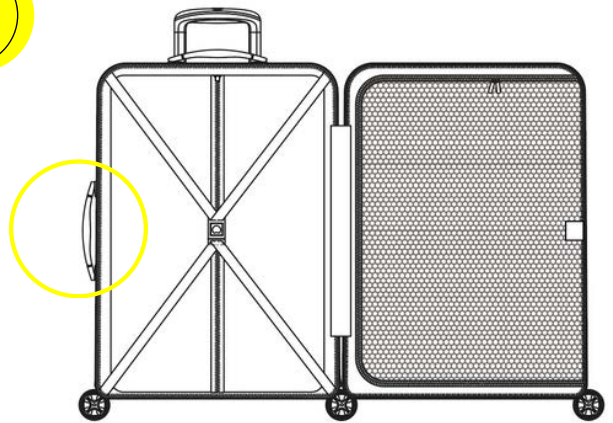
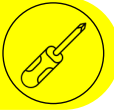

1
Ανοίξτε εντελώς τη βαλίτσα σας και ξεδιπλώστε τη στη μέση στο πάτωμα, φροντίζοντας οι δύο θήκες να είναι επίπεδες...



... για εύκολη πρόσβαση στην επένδυση.



2
Ανοίξτε προσεκτικά την εσωτερική επένδυση για να επιτρέψετε την άμεση πρόσβαση στο κόντρα πλακέ της λαβής και προσέξτε να μην καταστρέψετε το υλικό ή τις γύρω ραφές



Στο πίσω μέρος της λαβής, μια μικρή ενσωματωμένη καταπακτή παρέχει εύκολη πρόσβαση στη θήκη των μπαταριών.



Ανοίξτε προσεκτικά αυτή τη μικρή καταπακτή που βρίσκεται στο πίσω μέρος της λαβής και αντικαταστήστε τις δύο χρησιμοποιημένες μπαταρίες κουμπιών με νέες, φροντίζοντας να τηρείτε την υποδεικνυόμενη πολικότητα (+/-).



Τέλος, κλείστε το καπάκι της μικρής θυρίδας, θα πρέπει να ακούσετε έναν "κλικ". Κλείστε την επένδυση και μετά το φερμουάρ της βαλίτσας.