

---

# **User Manual**

## **REFRIGERATION AIR DRYER**

**Quality Dry Air**

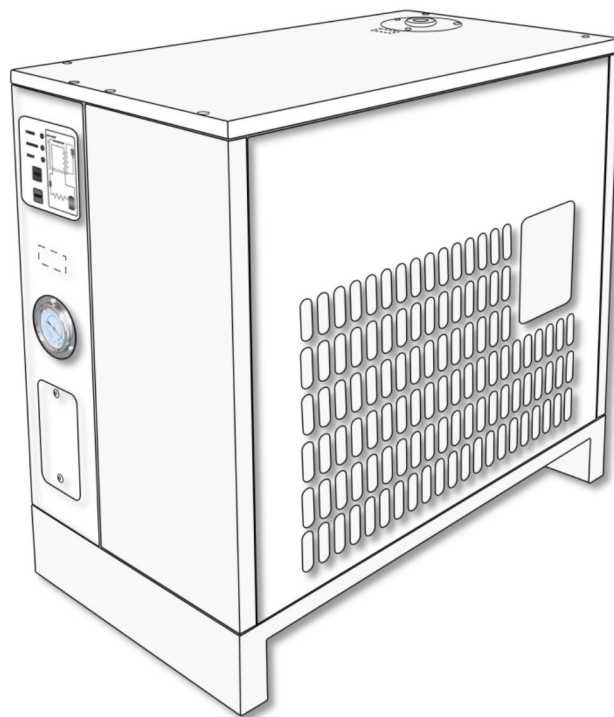

---

# Catalog

Foreword.....	1
General warning.....	1
Transportation and handling.....	2
Installation .....	2
Installation place avoided.....	3
Setup method.....	5
About air tubing.....	5
Water-cooled dryer installation.....	6
Water-cooled water pipeline.....	6
Condenser water pipeline.....	7
Cooling tower installation.....	7
Meets ISO8573.1 standard in distribution system.....	7
Electrical system.....	8
About power supply.....	8
Wind direction of fan.....	9
Electric circuit diagram.....	9
Working elements .....	12
Flow chart.....	12
Parts name.....	12
Operation method.....	13
Running method.....	13
Stop method.....	14
Stop and restart method.....	14
Periodic examination and management .....	14
Examination and management monthly.....	15
Cleanout automatic drain.....	15
Cleanout intake (inspiration gob).....	15
Condenser.....	15
Installation and usage of electronic drain valves attention matters.....	16
Overload state.....	16
Troubleshooting.....	17
Air pressure is too much.....	17
Drainage of water abnormal.....	17
Total not running.....	18
Ineffective running.....	19
Abnormally start.....	20
Automatic sewerage system abnormal.....	21
Certificate of inspection .....	22
Maintain card .....	23
Guarantee sheet .....	24

---

## Foreword

Thank you for choosing a product from our company. Although it has undergone rigorous testing prior to shipment, it is essential that you read this manual carefully and completely to ensure the machine's safe and reliable operation.

As we strive to enhance our product quality and features, we also welcome your feedback. Please inform us of any quality-related issues or dissatisfaction you encounter. We sincerely appreciate and will earnestly consider any practical suggestions you have for our production

## General warning

Before operation, the operator must verify that the operating environment meets the specifications outlined in the technical data section. This machine is designed for stable performance and high reliability.

However, any failure to install, configure, or operate the machine correctly may result in malfunctions or misleading error indicators. Therefore, if a fault occurs, the operator should:

- Check for any improper installation, configuration, or operation.
- Carefully inspect the machine for any abnormal sounds, vibrations, or performance.
- Identify and resolve the root cause.
- If the problem persists, contact our service department for technical support.

**Disclaimer:** The manufacturer shall not be held liable for any damages or injuries resulting from the user's failure to comply with safety procedures during operation, running, maintenance, or repair, even if such safety procedures are not explicitly stated in this manual.



To prevent malfunctions and accidents, follow all cautions properly and completely.

---

## **Transportation and handling**

Do not subject the dryer to throwing, severe impacts, or excessive vibration during handling or hoisting.

The dryer may be tilted to an angle below 45° for short-term transportation only. Avoid long-distance transportation with the unit in a horizontal position or at a steep angle, as this may cause damage to the compressor. A forklift truck or freight elevator may be used for handling, provided the unit is kept in its standard upright operating position. Take care to avoid damaging the equipment's outer casing.

1、 In order to avoid damage of the equipment and the components, please be careful when handling.

2、 For routine movement, use a crane and rollers. Never drag or pull the equipment forcibly.

3、 Lift the equipment only using a crane, attaching to the designated lifting points.

4、 Use pads to avoid damage.

## **Installation notice**

1、 Operators must follow all local and internal codes applicable to workplace safety and operation. Only qualified personnel are permitted to perform maintenance or repairs. For complex tasks, a second similarly qualified person must be present to supervise and assist. It is recommended that a specially appointed person oversees the operation of this machine.

2、 Never remove, change or adjust any protective or warning signs or safety device.

3、 Never remove any protection or safety device whether temporarily or permanently during the running of machine.

4、 Never perform the maintenance and repair until the machine is stopped and de-energized and also make sure that no accidental operation would possibly restart the machine. Make sure that no tools are left in the machine and there is no loose

- 
- 5、 component or other problem.
  - 6、 Make sure to read and understand this manual carefully and thoroughly. Any failure to follow procedures or caution described in this manual would lead to accident or injury.
  - 7、 Keep your body, handhold tools and other conductors away from exposed electric circuit.
  - 8、 Never start this machine in any unsafe condition. Never attempt to run this machine while where is any problem found.
  - 9、 Keep working pressure below the rated pressure for dryer (refer to the value on the nameplate attached to this machine).
  - 10、 Never apply the compressed air to the dryer while it is not in operation, otherwise moisture may accumulate on the wall in the back end pipeline damaging the quality of the compressed air. The correct procedure is to start the dryer first and wait for 3 minutes before applying compressed air.
  - 11、 Never operate the machine with incomplete phases(check the power supply for adequate voltage and complete phases),otherwise serious injury may occur.



Never start the machine under abnormal working condition. Refer to relevant information in this manual for normal working condition. It is recommended that, operators indicate in written that they have read this manual carefully, and that the manual is maintained properly. We are not liable for the loss of this manual.

## **Installation place avoided**

1. It is strongly recommended that the dryer is equipped with a air receiver tank. Check and see if the position is appropriate for installation by firstly considering its effect on the operation of the machine and then the convenience for tubing. Make sure not to allow heat from the compressor or other heat sources to be discharged onto the dryer.

2. Keep the installation away from the combustible and explosive gas or goods.

3. Install the dryer in the clean, dry place and allow for sufficient space for convenient maintenance. Keep the machine away from wind and rain and maintain the ambient temperature at 36.5~77°F (The occasional running of the machine at 120°F would not cause damage but would affect the cooling capacity and dry air

4. dew point, and therefore, it is better not to run the machine at this temperature to prevent machine from tripping due to high pressure. Operation at ambient temperature.

5. To ensure normal operation of the machine, good ventilation is needed for the surround space of the machine to avoid overly high ambient temperature. Before installation, allow for sufficient space for the control panel, and make sure that there is an unblocked outlet and inlet for the cooling air.

6. At the place where there is a direct sunshine, heat emission would be affected, and therefore, the machine is not allowed to install at the place where there are much steam, oil gas, hot gas, and dust such as diesel engine, generator, chimney, painting, woodworking shop, cement mixing station, and

7. grinding machine.

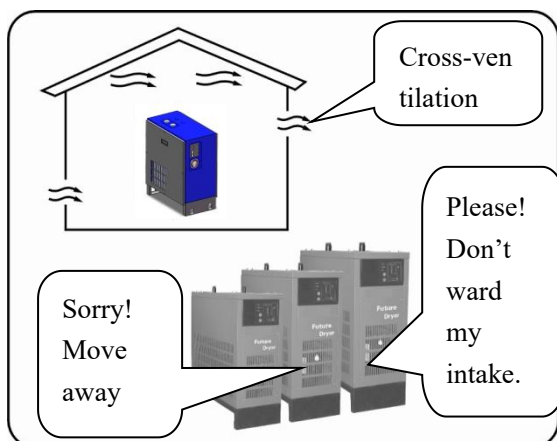

The installation site must be well-ventilated. Ensure there is sufficient unobstructed space around the unit for air to

circulate freely. If installed indoors, the room must have adequate ventilation to prevent hot spots, and the surrounding temperature must be maintained below 113°F.

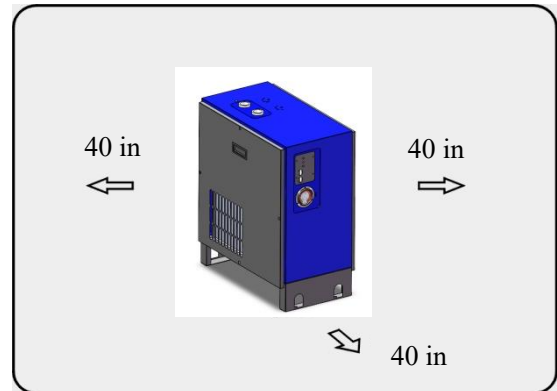

Surrounding area shall be more than

40 in away from such barrier like wall. The side without intake can be closed to the wall, but shall be move when maintenance.

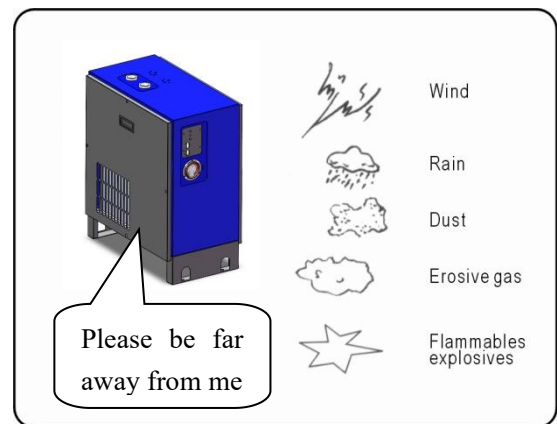

8. The machine should be installed, used and operated strictly in compliance with state or local legal provision, standard and regulations.

## Setup method

Generally, place them on the ground. No Special base is needed.

Please pay attention to the distance when two gas cooled dehumidifiers are placed together. Try not to place radiators face to face as those two have Function of absorbing heat.

Shaky places, acclivitous places, places Where drainage is easy to be clotted (if

need , please use heater to avoid clotting.)

Please directly suffered from rain or wind and humid places, places with much dust and places with erosive gas.

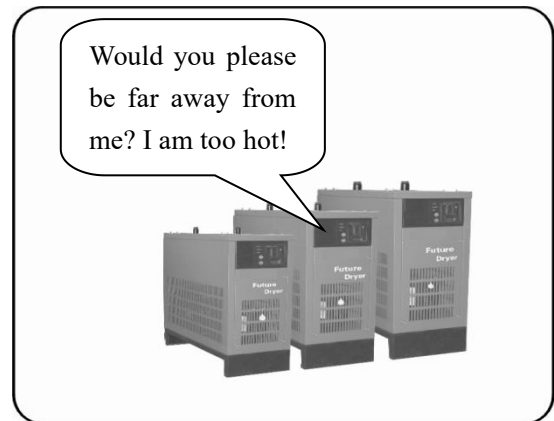

## About air tubing



Pay attention to the label on the machine

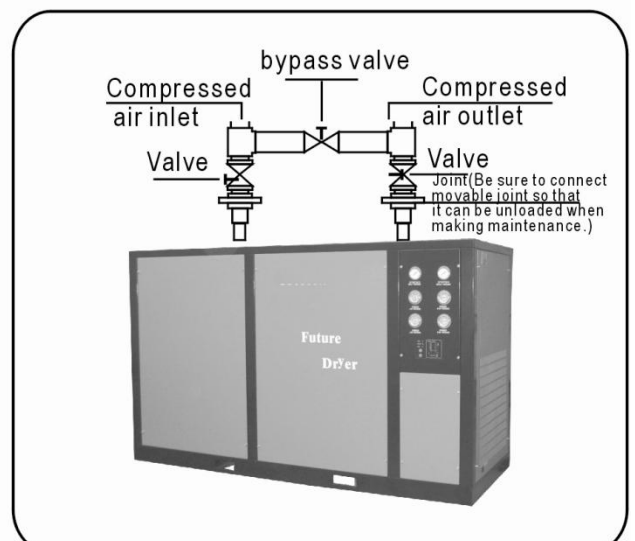
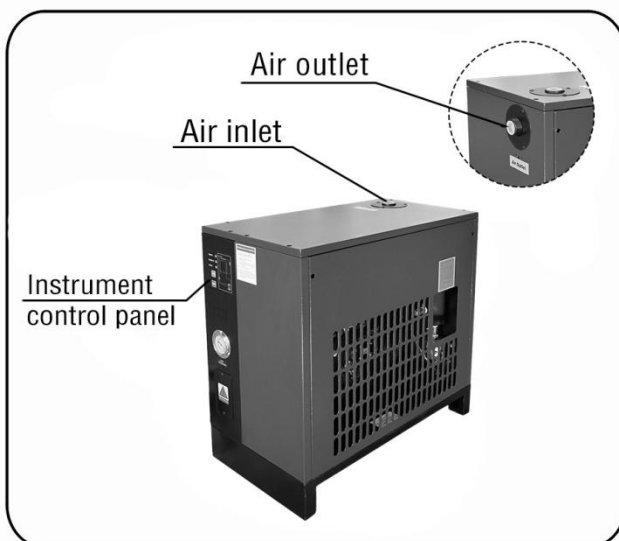

- 
- 1、 Adaptor union should be used to joint compressed air inlet and compressed air outlet.
  - 2、 Bypass piping should be used. (It must be ready for maintenance)
  - 3、 Make sure not to allow the piping is too long and pipe flexure angle is too small, avoidance differential pressure.
  - 4、 The piping should not be too heavy nor be over exerted.
  - 5、 Purge clean the piping with air before connection is made to keep dust and foreign substance from entering.
  - 6、 Make sure not to allow the vibration of the compressor to be transmitted to the dryer.
  - 7、 Air inlet of refrigeration air dryer must be installed main pipe-filter, The heat exchanger avoiding cold dry machine is contaminated outside by foreign substance and oil fog, Affect the cold dry machine heat exchange function.

## **Water-cooled dryer installation**

1. High water run off and low water temperature may cause frozen on the surface of the evaporator.
2. Low water run off and high water temperature may cause shutdown of the equipment due to the high pressure exceeding 2.3Mpa (333.6PSI).
3. The equipment can not be installed outside.
4. The following requirement must be observed when installing the equipment.
  - 1)Observe the relative regulations made by the local government and relative departments.
  - 2)Installation personnel must be in familiar with the local regulations.

## **Water-cooled water pipeline**

The installation of all pipeline system should conforms to the local regulations. The design of the pipeline must reduce bent and high/low move, which can save money and keep the best function.

The correct installation is as follow:

- 1.When maintenance and service, close the valve to separate the equipment from the pipeline system;
- 2.On the most top place of the pipeline system, set automatic exhaust valve instead of manual;
- 3.Keep sufficient water pressure in the system( i . e. adjust valve); Pressure of cooling water

---

above 0.15Mpa (21.8PSI), Entry temperature of cooling water below 89.6°F.

4. Install pressure meter and temperature meter for maintenance and service;
5. In front of the water pump, equipped with filter to eliminate the impurity of the water;
6. The diameter of the pipe shall be configured according to the distance and pressure.

## Condensation water pipeline

The pipeline of the condenser has been equipped before out of the factory. The site pipeline should be connected to the pipe on the equipment. The out take and intake pipe shall be connected with the pipe marked before out of the factory.

## Cooling tower installation

When the equipment connection with the cooling tower, a certain water pressure must be ensured. The water capacity flowing through the cooling tower should be stable. Meanwhile, no matter if the load and temperature outside change or not, the flow rate through the condenser must be adjusted, in order to keep stable cooling pressure and the lucidity of the condenser.

### Cooling tower installation

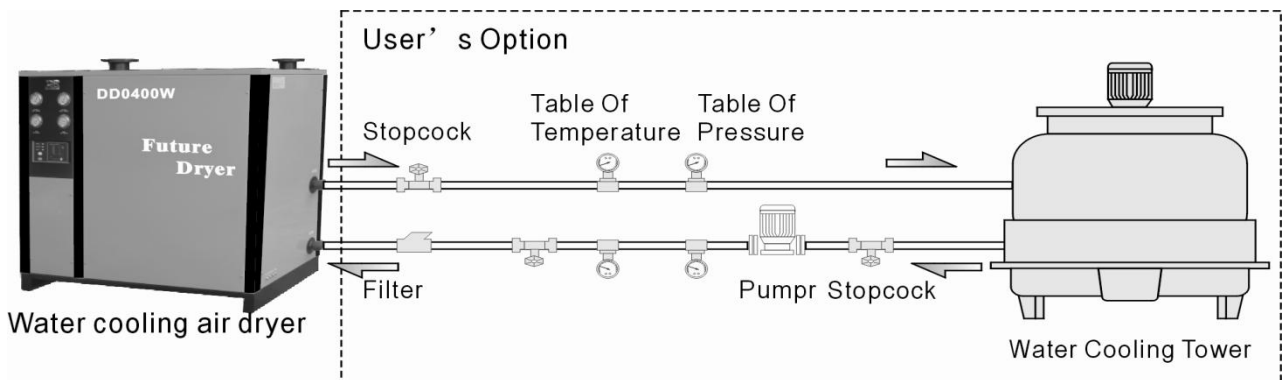

**Meets ISO8573.1 standard in distribution system**

## Compress air purification equipment installation

### Efficacy

### Range of application

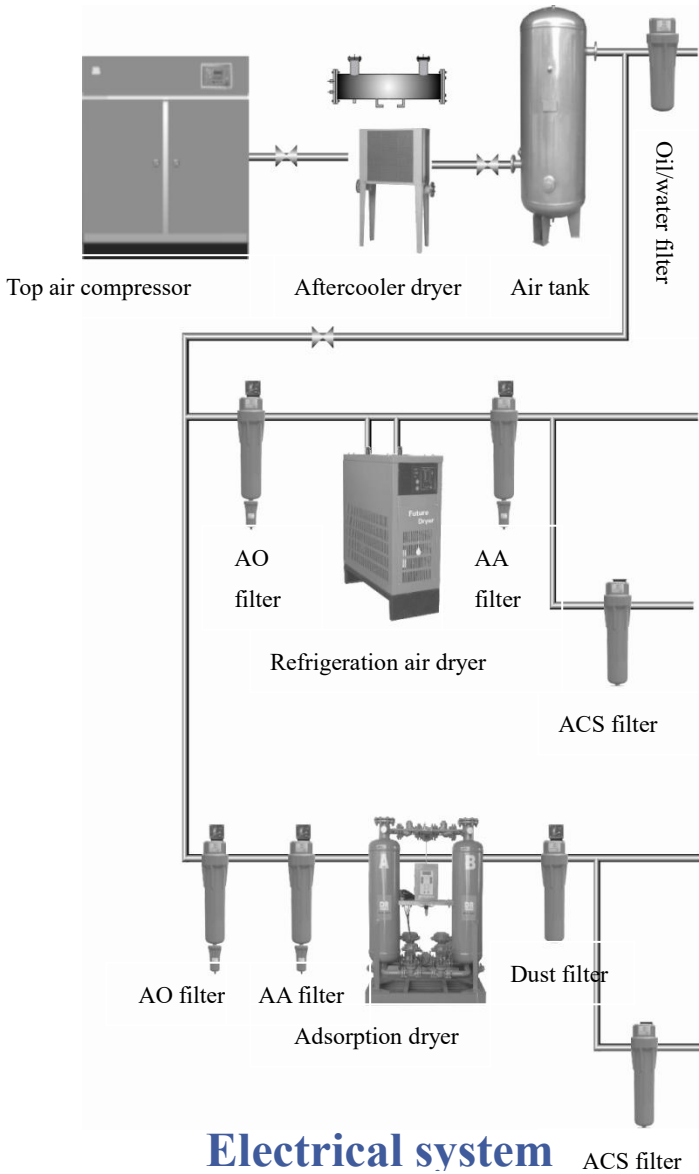

Get rid of 99% moisture, contents  
Oil content :5PPM  
Dust content:<3 $\mu$ m

It is swept , cool that  
general pneumatic  
machinery blows.

Pressure dewpoint:+37.4°F ~ +50°F  
Oil content:0.01PPM  
Dust content:<0.01 $\mu$ m

It apply and load with  
generally spray paint,  
it is Pneumatic instruments  
Pneumatic tool, valve, gushing  
out the sand, air Move and mix, the small  
and roundish thing products are sent.

Pressure dewpoint:+37.4°F ~ +50°F  
Oil content:0.003PPM  
Dust content:<0.01 $\mu$ m

Dive under water the  
homework, breathe the air  
food compound, pot Putting ,  
high pressure oxygen cabin,  
medicine the product is packed,  
medical dentistry, cosmetics.

Pressure dewpoint: -4°F ~ -94°F  
Oil content:0.01PPM  
Dust content:<0.01 $\mu$ m

Print, film industry,  
controlling accurately  
instrument, nuclear  
industry, aerospace industry.

Pressure dewpoint: -4°F ~ -94°F  
Oil content:0.003PPM  
Dust content:<0.01 $\mu$ m

The bioengineering,  
ferment are made and used  
systematically angry, but  
Afterwards connect the  
sterilization filter.

## Electrical system

### About power supply

- 1、 The power special supply, strictly observe the electrical safety regulations;
- 2、 Please use AC115V or 460V 3-phase special outlet;
- 3、 Please be sure to be equipped with leakage protection device;
- 4、 The power supply requirements are AC115V or 460V 3 phase 60Hz;
- 5、 Before using, please be sure to connect to the ground.

Special cable AC115V  
or 460V 3ph 60Hz

Power leakage  
breaker setup

Grounding



## Wind direction of fan

Wind from the fan of air-cooled dryer is directed to the coolant compressor. If, after the dryer with 3-phase power supply is started, the fan is found to rotate in the wrong direction, turn off the power supply, exchange any two of phases and restart the machine.

The dryer with single-phase power supply has been equipped with all control power cables as well as mainframe wiring before leaving the factory, and user can operate the machine by simply connecting it to the power supply specified on the nameplate.

This machine must be grounded properly to ensure the safety of maintenance person as well as the operator.

## Electric circuit diagram

<b>Ps1</b>	<b>High pressure switch</b>
<b>K1</b>	<b>Switch</b>
<b>KY</b>	<b>Electron draining</b>
<b>M1</b>	<b>Cooling media compressor</b>
<b>M2</b>	<b>Condenser electric motor</b>

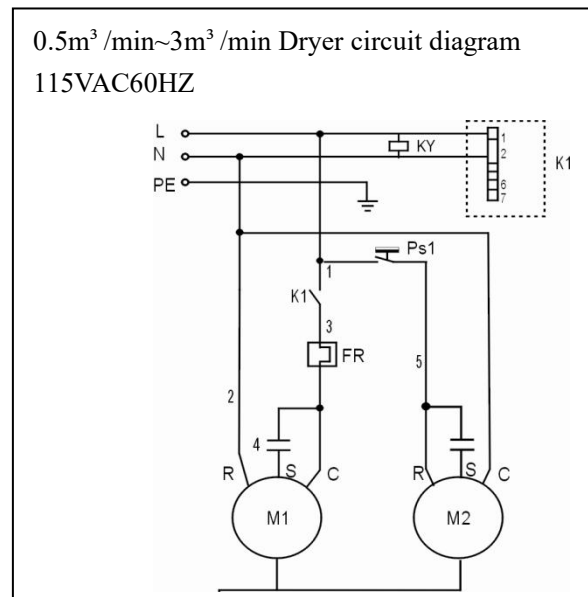

## Electric Swagram

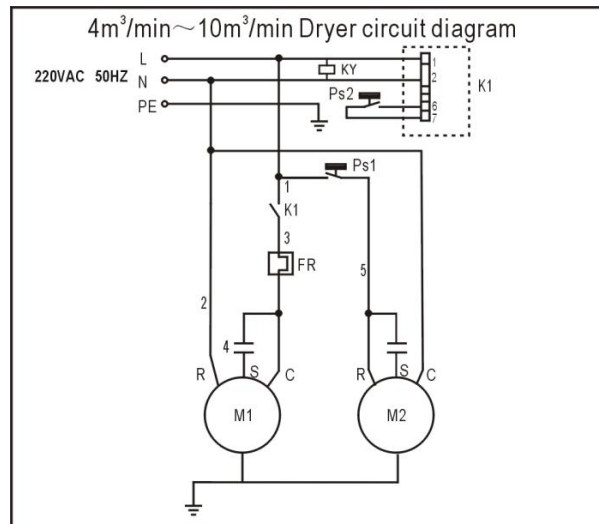

Ps2	High/low pressure switch
Ps1	High pressure switch
K1	Switch
KY	Electron draining
M1	Cooling media compressor
M2	Condenser electric motor

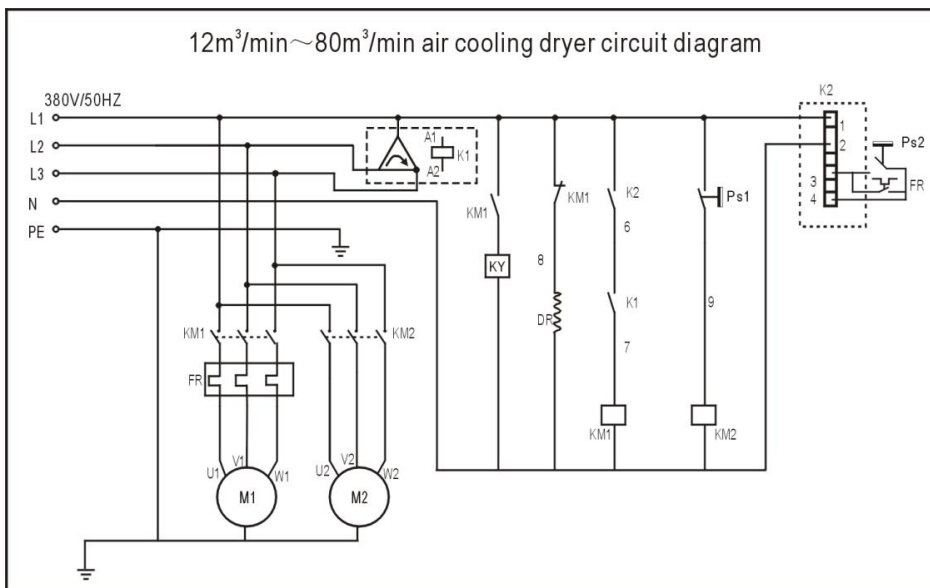

	Compressor theater
FR	Hot relay
KM1/KM2	AC contact
K2	Switch
K1	Relay
Ps2	High/low pressure switch
Ps1	High pressure switch
KY	Electron draining
M1	Cooling media compressor
M2	Condenser electric motor



# Working elements

## Flow chart

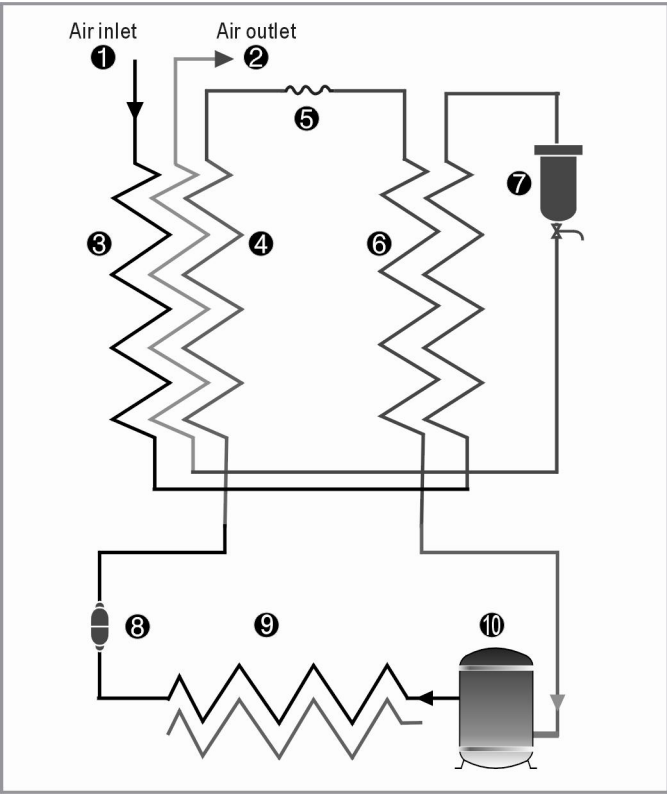

- |                         |                            |
|-------------------------|----------------------------|
| 1. Air inlet            | 2. Air outlet              |
| 3. Pre-cooler           | 4. Energy recycle          |
| 5. Capillary            | 6. Evaporator              |
| 7. Gas-liquid separator | 8. Desiccation Filter      |
| 9. Cool condenser       | 10. Refrigerant compressor |

### Parts Name



Cooling media compressor



Desiccation filter

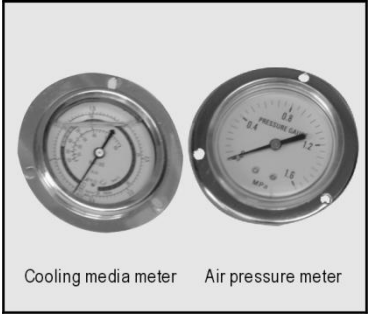

Cooling media meter    Air pressure meter

Meter

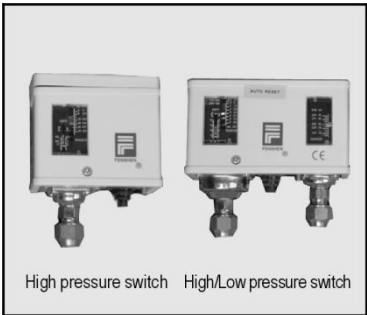

High pressure switch    High/Low pressure switch

Pressure switch

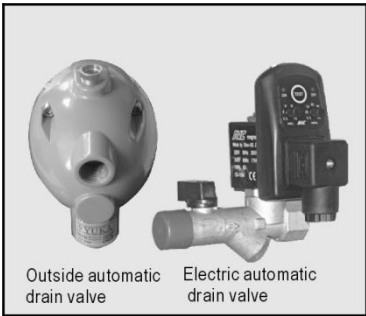

Outside automatic drain valve    Electric automatic drain valve

Automatic drain valve

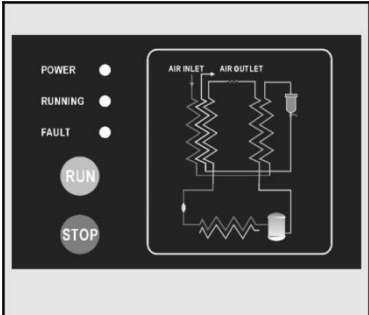

Control panel

---

## Operation method

### Check list before operation

1. Check for the power requirement: single phase voltage AC115V±5% or 3 phase voltage 460V±5%;

2. Check for the cooling system : observe the cooling system meter and air pressure meter. The two meters should be balance on a certain pressure which is. Normally it should be within 0.5 Mpa~1.2Mpa (72.5PSI ~ 174.0PSI).

3. Check the air pipe if normal , the intake pressure must not exceed 1.0Mpa (145PSI)(except special type). It is better to follow the required intake temperature of certain type;

4. If you choose the water type, check the cooling water if normal, the water pressure should be 0.15Mpa~0.4Mpa(21.8PSI~58.0PSI), the water temperature should be  $\leq 89.6^{\circ}\text{F}$

### Running method

1. Please confirm the selection of setting site, power connection、 installation of pipes and its automatic drainage if ok;

2. On control panel, press “RUN” key button;

3. Once the “RUNNING” light turn on, the fan motor of condenser will run automatically to remove hot air;

4. The fan motor will run and stop depending on the compress air and temperature of the environment, if the machine goes on running, the high-pressure gauge reading may exceed 1.6Mpa(232.1PSI), and will overload;

5. When the machine working normally, the water will flow out from the automatic drain;

6. It is better to let the machine continually running, often press the “RUN” and “STOP” key may damage compressor;

---

## Stop method

1. Press OFF or STOP to turn off the machine;
2. The green light and the machine will turn off but the fan will keep on running until such time there is no hot air inside;

## Stop and restart method

There are least 3 minutes interval between the start and stop of the cooled dryers, in order to reach pressure compensation during the refrigerator circulation. (Avoid too high-pressure difference inside the system.)

## Periodic examination and management

### Daily examination

#### Light

On control panel, press “RUN” key lightly, has light “RUNNING” been bright?

#### Draining away water voluntarily

Does the automatic sewerage drain out periodically? If the drainage is not smoothly, press automatic sewerage cleaning for clean.

#### Pressure gauge

During running, when the evaporator pressure meter indicates in 0.3~0.6Mpa(43.5 PSI~87.0 PSI), it is the best working state.

#### Cooling water

During running, if the cooling water in gear? Water pressure is in 2~4kg/cm<sup>2</sup>(28.4 ~ 56.9 PSI), the water max. Temperature does not exceed 95°F.

---

## Automatic drain

Check with manual button(TEST) every day and see if there is any water coming out. The electronic drainer can be timed as required by customer with sec for second and min for minute. Make sure not to allow water to drip down on the drainer causing electric short circuit and damage.

## Examination and management monthly

### Cleanout automatic drain:

Clean it monthly can avoid the abnormal operation.

### Cleanout intake (inspiration gob):

Use cleaner, brush ball or sprayer to clean the radiator once every week. Clean the dust on the intake at the right side(front). Turn off the drainage valve and turn on the ball valve.

## Condenser

The cleaning frequency of the condenser is decided by many factors. It is not necessary to give a certain period. Some are cleaned once a year, but some are cleaned several times a year. Because of the special structure, it cannot be cleaned manually. It should be cleaned with chemical method.

### Installation diagram of electronic drain valves

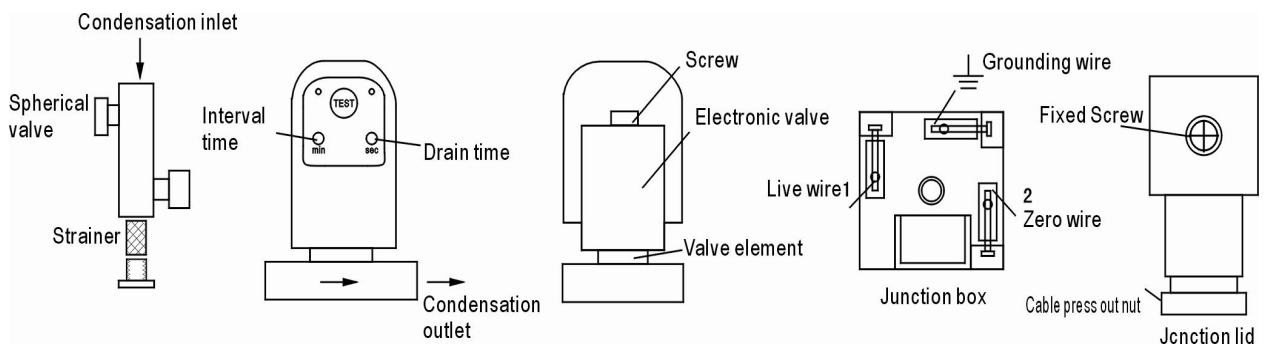

---

## Installation and usage of electronic drain valves attention matters

### Electronic drain valves attention matters

1. Connection cable used three element outline cable and confirmation floor, usage required electrical source.

2. Before installation drain valve, at first cleaning out the dirt, rust in the air compressor system, new machine must be cleaned strainer on time once week(turn off spherical valve first), after continuous using three months, at least clean strainer one time once month.

3. If electrical valve isn't leaded to by quality, just because condensation water is too dirty. Some tiny solid grain enter between valve element and shunk. So locked valve element.

### Adopt follow way to eliminate obstacle.

1. Constantally press test button several times until eliminate obstacle.

2. If the above way isn't useful, please taking apart electrical valve, cleaning valve element:

1)Turn off interval valve, pressing out test button to the gas, making sure interval electrical drain valve and air system, that means lower zero pressure;

2)Cut off drain valve electrical source;

3)Take off winding(before taking off winding, making sure cut off electrical source, otherwise winding will be burn out). Taking apart electrical valve, and taking off valve element and spring, wash valve, element and spring, and then installation again, the obstacle will be eliminated.

### Pay attention

During dryer running, if the evaporator pressure meter indicates overrun bule, which means overload state. Please check the following "overload state" conditions.

### Overload state

Running at the following state will cause overload with the action of protecting the equipment, and running stops.

1. The temperature of compressed air is too high;

2. The capacity of compressed air is too large;

- 3. Temperature around is too high (above 113°F);
- 4. Intake is blocked by wall or dust.

## Troubleshooting

The troubles caused by the cooled compressed air dryers itself on the outside factor is caused by the following six factors and troubleshooting.

### 1. Air pressure is too much

Phenomena	Reasons	Troubleshooting
Air pressure at operation site is worse than the large site	The valve of pipeline does not totally	Open the valve totally
	Diameter of tube is too small	Enlarge the diameter of pipe
	Pipeline is too long	Re-design the pipeline system
	Too many elbows and joints	Check elbow and joint
	The connection of pipeline is leaking	Clean the filter or replace the core of the filter
Air insufficient	The runoff blocked by the filter in the pipeline exceeds the rating of air compressor	<ol style="list-style-type: none"> <li>1. Replace the air compressor with large capacity</li> <li>2. Reduce the airflow rate</li> </ol>
Air and condenser frozen	The runoff reducing the temperature switch has trouble	Renew the temperature switch
	Expanding valve block	Renew expanding valve

### 2. Drainage of water abnormal

Phenomena	Reasons	Troubleshooting
Abnormal indication	Air bypass valve does not close totally	Close bypass valve

	Air does not pass the dryer	Close down dryer entry & exit valve
	Air runoff is large and pressure is too large	Re-design air compression system
	Sewerage is much higher than automatic sewerage	Re-setup sewage system
	Sewerage abnormal	Cleaning or replacing
	Bad matching of compressor and dryers	Re-design the matching
	Whether or not the inlet and outlet of the compressor air are connected reversely	Rechecking
Orate temperature	Drier needs a renewal in	Check the compressor's load
	Exit and entry valves' system	Select good positioning or improve the ventilation
	Check the expansion valve condition	Replace the expansion valve
	Cooling media leakage	Check the cooling media or re-fill-up cooling media
	Meters damage	Replace meter

### 3. Total not running

Phenomena	Reasons	Troubleshooting
Powerless	Fuses break or non-fuse on and breaks	Be sure if there is short-phase or short-circuit of power supply
	The voltage	Check the fuse and fine the place of breaking
	Transformer failure	Replacing transformer
Whether there is power or non-power	Abnormal, or power cord is too thin	According to the rating currency on the nameplate
	Low voltage poor of contact	Exchange any two of phases
	Poor switch or poor of contact	Replacing new contact
	Over relay abnormally	Replacing new over relay

	Capacitor abnormally	Replacing new capacitor
	High/low pressure abnormally	Replacing new high/low pressure switch
	Temperature switch abnormally	Replacing new temperature switch
	Compressor does not reset after	Replacing new compressor
	Time relay failure	Repair or changes time relay
Switches are normal but do not start	High/low pressure skipping	After finding out the of skipping, reset or replace
	Electromagnetism does not reset after opening/closing O.L	
	Opening /closing of high pressure does not reset	
	Error set of temperature open/close	Replacing new temperature switch
	Compressor is abnormal	Replacing new compressor
	Defective auxiliary relay	Repair or replace auxiliary relay

#### 4. Ineffective running

Phenomena	Reasons	Troubleshooting
Too low evaporation temperature	Bad evaporating temperature meter(low pressure meter)	Replace evaporating temperature meter
	Blocked expansion valve	Replace expansion
	Temperature switch or pressure switch set low	Re-setup
	Leaking cooling-media	Examine out where to leak, and adds to irrigate cold matchmaker
Too high surrounding temperature	Too high evaporating temperature	Improve the ventilation
	Back heat-air bypass valve	Adjust or replace the heat-air bypass valve
	Blocked condenser	Clearing

	Too much air processing	Re-design the matching
	Worn-out cooling-media compressor valve-plates	Replace the compressor

## 5. Abnormally start

Phenomena	Reasons	Troubleshooting
Abnormal voltage	Power cord short-circuit with scorch smell not long after starting	Chain control circuit and switch need check-up to
High pressure break, difficult to reset and start	Pressure switch abnormal	Replace new pressure switch
	Fan abnormal	Replace new fan
	Overload break	Problems in motor or other places
	Condenser scaled	More clean out
	Too much refrigerant	With suitable refrigerant
	Too high surrounding temperature	Change environmental, good ventilation
	Expanding valve blocked	Replace new expanding valve
	Filter blocked	Replace new filter
Overload breaks	Start capacitor, pressure switch abnormal	Renewing pressure switch
	Capacitor abnormal	Renewing capacitor
	Defective pressure switch	Replace pressure switch
	Compressor overload	Dryer overload, reduce air follow rang
	Too high surrounding temperature	Improve condition temperature
	Setting current valve too low	Contacting owing to bad contact
	Poor contact	Repair or renew

	Power supply loss-phase	Check the reason for loss-phase
	Poor contact of the contractor	Replace a new contactor

## 6. Automatic sewerage system abnormal

Phenomena	Reasons	Troubleshooting
System drain abnormal	Working pressure 0.15 MPa (21.8PSI)	Normal operation pressure 0.2~1 MPa (29PSI~145PSI)
	Drain valve damage	Replace drainage valve
	Drainage valve incline or damage	Replace sewerage
	Sewerage stop or damaged, filter blocked	Clean drainage
	Operation pressure too high	Please use according to the rated pressure of automatic sewerage
	Out take blocked	Clean drainage
	Excessive system water volume	Using manual water drainage

Pay attention to: when cleaning automatic drain valve, strictly prohibiting from using gasoline, toluene, colophony water etc. to corrode nature impregnant.

---

## Certificate of inspection

Air Dryer

Model	
Air inlet temp.	
Volume of flow m <sup>3</sup> /min	m <sup>3</sup> /min
Manufacture number	
Leave the factory date	
QC	
<p><b>This product carries out the standard:</b> <b>JB/T10526-2005</b> <b>《Refrigeration compressed air dryers for general use》</b></p>	

---

## Guarantee Card

Air Dryer

Customer			
Date of purchase		Tel	
Address of installation			
Mode		Production code	
Fault record:			

---

## Guarantee Sheet

Thank you for choosing our air purification equipment.

We warrant that this product is free from defects in materials and workmanship under normal use and service. This warranty is valid subject to the following terms and conditions:

### 1. Warranty Coverage and Duration

The warranty period for this product is one year from the date of original purchase.

During the warranty period, we will, at its option, repair or replace any defective components free of charge, provided the product is used in accordance with the user manual.

### 2. Conditions That Void Warranty

This warranty shall not apply if the product defect or failure is a result of:

Improper installation, operation, or maintenance not in accordance with the product manual.

Misuse, abuse, accident, or modification by the user.

Acts of nature, including but not limited to fire, flood, lightning, or earthquake.

Use of non-original or unauthorized parts.

Normal wear and tear of consumable parts (e.g., filters, gaskets).

### 3. Consumable Parts

Consumable parts, such as filters and automatic drain valves, are excluded from this warranty unless failure occurs due to a defect in materials or workmanship under normal use.

### 4. How to Obtain Warranty Service

---

To obtain service under this warranty, please:

Contact our customer service center to obtain a Return Merchandise Authorization (RMA) number.

Present the original proof of purchase (receipt or invoice) and this warranty certificate.

The product must be returned freight-prepaid to an authorized service center specified by us.

**Disclaimer**

All information in this manual is correct at the time of printing. We reserve the right to make changes in technology and specifications without prior notice. These changes may also be applied to products already ordered.

