

# BrassCraft®

## Cable Drum Machine Operation Manual BC3020







Used For: Sinks, Tubs, Floor Drains and Roof Stacks  
(Not for roots)



**⚠ WARNING** READ THIS OPERATION MANUAL CAREFULLY BEFORE USING THIS PRODUCT. FAILURE TO UNDERSTAND AND FOLLOW THE CONTENTS OF THIS MANUAL MAY RESULT IN ELECTRICAL SHOCK, FIRE, AND/OR SERIOUS PERSONAL INJURY OR DEATH. KEEP THESE INSTRUCTIONS IN A SAFE PLACE FOR FUTURE USE OR WHEN LOANING OR SELLING THE PRODUCT.

## SAFETY SYMBOLS & SIGNAL WORD

In this Operation Manual and on the product, safety symbols and signal words are used to communicate important safety information. This section is provided to improve understanding of these signal words and symbols.

	<ul style="list-style-type: none"> <li>This is the safety alert symbol. It is used to alert you to potential physical injury hazards. Obey all safety messages that follow this symbol to avoid possible injury or death.</li> </ul>
	<ul style="list-style-type: none"> <li>This symbol signifies the importance of the user to read the operator's manual carefully prior to using the machine. The manual encompasses essential information regarding the safe and proper operation of the equipment.</li> </ul>
	<ul style="list-style-type: none"> <li>This symbol denotes the significance to always wear safety glasses with side shields or goggles when handling or using this equipment to reduce the risk of eye injury.</li> </ul>
	<ul style="list-style-type: none"> <li>This symbol denotes the risk of fingers getting trapped in a belt and/or pulley.</li> </ul>
	<ul style="list-style-type: none"> <li>WARNING indicates a hazardous situation that, if not avoided, could result in death or serious injury.</li> </ul>
	<ul style="list-style-type: none"> <li>This symbol indicates the risk of hands, fingers or other body parts being trapped, wrapped or crushed in the drain cleaning cable.</li> </ul>
	<ul style="list-style-type: none"> <li>This symbol designates the risk of electrical shock. This could result in death if the machine is plugged into an improperly wired outlet.</li> </ul>

## CABLE DRUM MACHINE SAFETY

### Read all safety warnings and instructions.

Acquaint yourself with the functions and controls prior to using this machine. Should you have any questions about the operation or use of this machine, please call Customer Service (toll free) at 877-319-3757. If you have any uncertainties about how to use this machine, contact a drain cleaning specialist. **▲ Failure to follow the instructions and warnings may result in electric shock, fire, serious injury or even death.**

### Make Sure This is The Right Tool For Your Job

- This cable drum machine is intended for use in sinks, tubs, floor drains and roof stacks with 2 inch to 4 inch diameter lines.
- This machine is **NOT** designed to clear tree roots from pipes – attempting to clear tree roots can result in injury and will damage the machine/cable, in-turn voiding the warranty. For clearing root disturbances, utilize a larger drain cleaning machine such as the BrassCraft 650 series.
- Do not modify this product or use it for anything other than its intended purpose. Only use equipment suggested by the manufacturer. Alterations or other improper use could result in personal injury or damage to the product also nullifying the product warranty.

### Personal Protection Equipment

- Wear snug fitting leather gloves when operating this machine. Never grasp the rotating cable with anything else, including a rag or non-leather gloves.
- Wear safety glasses or eye protection 
- Exercise cleanliness. Use hot soapy water to clean hands and other body parts that may have been exposed to drain cleaning contents. To reduce the risk of contamination and illness, do not eat or smoke while cleaning drain.

### Personal Safety

- Stay alert, watch what you are doing and use common sense when operating a power tool. Do not use a power tool while you are tired or under the influence of drugs, alcohol or medication. A moment of inattention while operating power tools may result in serious personal injury.
- Use personal protective equipment. Always wear eye protection. Protective equipment such as dust mask, non-skid safety shoes, hard hat, or hearing protection used for appropriate conditions will reduce personal injuries. 

**▲ WARNING** WARNING indicates a hazardous situation that, if not avoided, could result in death or serious injury.

### Save all warnings and instructions for future reference.

- The term "power tool" in the warnings refers to your mains-operated (corded) power tool or battery operated (cordless) power tool.
- Prevent unintentional starting. Ensure the switch is in the off-position before connecting to power source and/or battery pack, picking up or carrying the tool. Carrying power tools with your finger on the switch or energizing power tools that have the switch on invites accidents.
- Do not overreach. Keep proper footing and balance at all times. This enables better control of the power tool in unexpected situations.
- Dress properly. Do not wear loose clothing or jewelry. Keep your hair, clothing and gloves away from moving parts. Loose clothes, jewelry or long hair can be caught in moving parts.

# BrassCraft®

- If devices are provided for the connection of dust extraction and collection facilities, ensure these are connected and properly used. Use of dust collection can reduce dust-related hazards.
- When lifting heavy objects, always lift with your knees, never with your back. Consider using two people when lift is heavy and/or awkward.

## Proper Machine Operation

- **Cleaning chemicals can be present in clogged drains.** If you have previously used chemicals or are unsure, take precise care to avoid contact with the cable or debris found in the drain.
- **⚠️ WARNING** Machine is designed to be used by one person only. The operator must control both the cable and the foot switch. Should the cutter stop rotating, the operator must be able to turn the motor off. This helps to prevent kinking and breaking of the cable which could cause crushing or striking injuries.
- **⚠️ WARNING** Do not allow the cable to twist, kink or build up tension. Do not let the cable endure overstressed situations. This could potentially result in crushing and/or striking injuries and unpredictable cable reactions. If the cable starts to become overstressed, immediately turn the machine off and rotate the cable in the opposite direction until the twist or buckle has been removed.
- **⚠️ WARNING** Do not operate machine with motor in reverse. Reverse is only used when the cable is stuck or overstressed. Running the machine in reverse could result in possible kinked or stressed cable and potential injury.
- **⚠️ WARNING** Never retract the cable from the inlet while drum is spinning. The cable could whip around and cause serious injury and possible death.

## Work area safety

- **Keep work area clean and well lit.** Cluttered or dark areas invite accidents.
- **Do not operate power tools in explosive atmospheres, such as in the presence of flammable liquids, gases or dust.** Power tools create sparks which may ignite the dust or fumes.
- **Keep children and bystanders away while operating a power tool.** Distractions can cause you to lose control.

### **⚠️ WARNING** **Electrical Safety**

- **Power tool plugs must match the outlet. Never modify the plug in any way. Do not use any adapter plugs with earthed (grounded) power tools.** Unmodified plugs and matching outlets will reduce risk of electric shock.
- **Avoid body contact with earthed or grounded surfaces such as pipes, radiators, ranges and refrigerators.** There is an increased risk of electric shock if your body is earthed or grounded.
- **Do not expose power tools to rain or wet conditions.** Water entering a power tool increases the risk of electric shock.

- **Do not abuse the cord. Never use the cord for carrying, pulling or unplugging the power tool. Keep cord away from heat, oil, sharp edges or moving parts.** Damaged or entangled cords increase the risk of electric shock.
- **When operating a power tool outdoors, use an extension cord suitable for outdoor use.** Using a cord suitable for outdoors reduces the risk of electric shock.
- **If operating a power tool in a damp location is unavoidable, use a ground fault circuit interrupter (GFCI) protected supply.** Use of a GFCI reduces the risk of electric shock.
- **Remove any adjusting key or wrench before turning the power tool on.** A wrench or a key left attached to a rotating part of the power tool may result in personal injury.

## Power Tool Use and Care

- **Do not force the power tool. Use the correct power tool for your application.** The correct power tool will do the job better and safer at the rate for which it was designed.
- **Do not use the power tool if the switch does not turn it on and off.** Any power tool that cannot be controlled with the switch is dangerous and must be repaired.
- **Disconnect the plug from the power source and/or the battery pack from the power tool before making any adjustments, changing accessories, or storing power tools.** Such preventive safety measures reduce the risk of starting the power tool accidentally.
- **Store idle power tools out of the reach of children and do not allow persons unfamiliar with the power tool or these instructions to operate the power tool.** Power tools are dangerous in the hands of untrained users.
- **Maintain power tools. Check for misalignment or binding of moving parts, breakage of parts and any other condition that may affect the power tool's operation. If damaged, have the power tool repaired before use.** Many accidents are caused by poorly maintained power tools.
- **Keep cutting tools sharp and clean.** Properly maintained cutting tools with sharp cutting edges are less likely to bind and are easier to control.
- **Use the power tool, accessories and tool bits etc. in accordance with these instructions, taking into account the working conditions and the work to be performed.** Use of the power tool for operations different than those intended could result in a hazardous situation.

## Service

- Have your power tool serviced by a qualified repair person using only identical replacement parts. This will ensure that the safety of the power tool is maintained.

## MACHINE DESCRIPTION

This machine has manual cable feed. The cable must be fed by hand and does not automatically extend or retract into the machine.



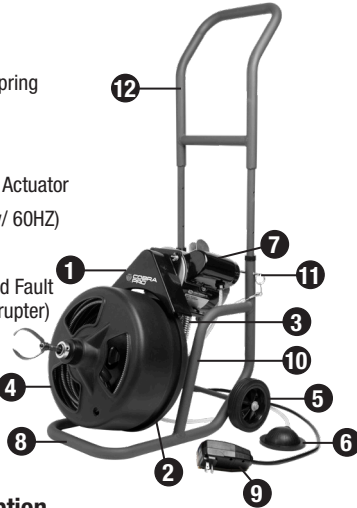

This machine should not be operated in reverse under normal operating conditions. Reverse should be used only for a few seconds at a time to free a stuck cutting tool.

1. Belt Guard
2. Belt
3. Extension Spring
4. Cable Drum
5. Wheels (2)
6. Foot Switch Actuator
7. Motor (115v/ 60HZ)
8. Base Frame
9. GFCI (Ground Fault Circuit Interrupter)
10. Uprights (2)
11. Frame release pin
12. Telescoping Handle



## Tool Description

Your cable drum machine has four beneficial tool attachments to cope with a wide variety of obstructions. As a general guideline, it is wise to use a tool that is at least 1" smaller than the line to be cleared. The nature of the job and the operator's judgment should determine the type of tool.

	<ul style="list-style-type: none"> <li>• ST-96205</li> <li>• 3/4" x 5" Straight Boring Head for initial exploration of clog</li> </ul>
	<ul style="list-style-type: none"> <li>• ST-96207</li> <li>• 1-1/2" x 2" Slotted Spear Head for piercing clogs</li> </ul>
	<ul style="list-style-type: none"> <li>• ST-96201</li> <li>• 1-1/4" x 2" Grease Cutter for grease blockages</li> </ul>
	<ul style="list-style-type: none"> <li>• ST-96208</li> <li>• 2" x 4" Side Cutter for finishing pipe cleaning</li> </ul>

## PREPARATION FOR OPERATION

### ⚠ WARNING

**Do not operate a machine that has the belt guard removed, any absent or broken parts, or that is incorrectly assembled.** If your machine does not meet all of the conditions in this section, do not operate until the machine is properly repaired (See Repairing Your Drum Machine). Failure to properly prepare for operation may result in shock, fire, and/or serious personal injury or death.

### Check Your Personal Protective Equipment

Be sure your personal protective equipment (See Personal Protection Equipment Section) is in good condition. Before use, ensure gloves are not damaged.

### Prepare the Work Area

- Make sure the work area has satisfactory lighting.
- Do not work in areas that have combustible liquids, dust or vapors that may ignite. The drain machine is not explosion resistant and can create sparks.
- Do not work in any area until all the flammable sources have been identified and corrected.
- Never place the machine in water. If necessary remove the water from the work area prior to use.
- Be sure the electrical outlet is properly grounded. If unsure, have the outlet inspected by a licensed electrician.
- Make sure the path for the power machine transportation and power cord are clear of obstructions. Any potential sources of damage to the power cord or machine should be relocated prior to use.
- Keep bystanders and children away from the work area.
- Drain cleaning can be messy. If necessary, use protective covers.

### Inspect and Prepare the Drain

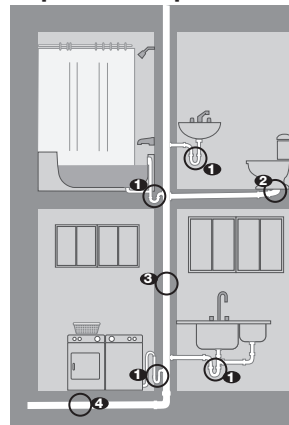

- Determine if cleaning chemicals have been used in the drain. If chemicals are present, contact the chemical manufacture to understand the safety measures that are necessary to work around those substances.

• Properly inspect the drain. Determine the best access point to the drain and the size of the drain. If possible,

determine the distance to the blockage or the nature of the clog. If necessary, remove the fixture (toilet, sink, etc.) to allow access to the drain.

---

## PREPARATION FOR OPERATION

---

### Inspect and Prepare the Machine

- **Verify machine and components are in place.**
- **Inspect your drain cleaning gloves to ensure they are in good condition with no holes, tears or loose sections.** It is critical to have the proper gloves to protect your hands from the rotating cable.
- **Make sure the drain cleaning machine is unplugged and inspect the Ground Fault Circuit Interrupter, plug and power cord for any damage.** If the plug has been modified or is missing any components, do not use the machine. It will need to be repaired by a qualified person prior to use.
- **Ensure the foot switch is attached to the machine properly.** Do not operate the machine without the foot switch.
- **Before use, clean any grease, dirt or oil off the equipment controls and handles.** This will reduce the risk of the machine or controls slipping from your grip.
- **Confirm that the machine is accurately assembled.** Look for any parts that are not in a condition which would prevent safe and normal operation.
- **Rotate the drum and make sure that it smoothly rotates.** If any problems are found, or if you are unsure, do not use the machine until it has been properly repaired.
- **Ensure that the belt guard is fastened securely to the machine.** Do not operate without the guard properly assembled.
- **Make sure the warning label on the motor is intact and readable.** Do not operate the machine without the warning label.
- **Clean any debris from the tools and cable while inspecting the cable for any wear and damage.**
- **Check for flats on the outside of the cable, if any portion looks as though it is not round, the cable should be replaced.** Inspect the cable for any kinks, space between the coils or excessive corrosion. These can weaken the cable during use.
- **Inspect the cutting tools for any damage or wear.** If damage or wear is found the tools need to be replaced.
- **Confirm that the FOR/OFF/REV switch is in the OFF position.** Using dry hands, plug the cord into a correctly grounded outlet. To test the GFCI provided, push the test button in, the indicator light should go off. Restart by pushing the reset button in. If the indicator light goes on, the GFCI is functioning properly. If it is not working properly, unplug the cord and do not use the machine till it has been correctly fixed.
- **Move the FOR/OFF/REV switch to the FOR position.** Slowly press the foot switch and note the direction of rotation of the drum. If the foot switch does not rotate the drum, do not use this machine and have it properly inspected. The drum should rotate counter clockwise when viewing from the front of the machine. Move the switch to the REV position to ensure that the drum is rotating clockwise, repeating the previous steps to ensure that the machine is working properly. If the rotation is not correct, do not operate this machine.

---

## OPERATING INSTRUCTIONS

---

### WARNING

If your machine is not properly operating, do not use it until the machine is properly repaired.

### WARNING

Do not allow the cable to twist, kink, buckle, become overstressed or stuck. If the cable begins to get stuck or buckle/twist, immediately remove your foot from the foot switch while firmly holding the cable with both hands. Allow the machine to come to a complete stop and the tension to release from the cable. Turn the machine off and immediately manually rotate the cable in the opposite direction until the twist or buckle has been removed.

### WARNING

If the cutter is stuck in the clog, turn the machine into the OFF position, then to REV and slowly press the foot switch. Let the machine run slowly in reverse, stopping the motor often to checking if the cutter has become released, by manually retrieving the cable into the drum. ONLY run the motor in REV if the cutter has become caught. If the cable begins to get stuck or buckle/kink/twist, immediately remove your foot from the foot switch while firmly holding the cable with both hands. Allow the machine to come to a complete stop and the tension to release from the cable. Turn the machine off and immediately manually rotate the cable in the opposite direction until the twist or buckle has been removed.

### WARNING

Fingers or other body parts can be caught in rotating parts and crush. Do not wear loose clothing, neck ties, unbuttoned jackets, rings, watches or jewelry and always tie back long hair. This will prevent the risk of entanglement with moving parts. This machine has manual cable feed and does NOT automatically extend or retract into the machine. Cable MUST be fed by hand. You will use the machine to clear obstructions, returning to hand feeding the cable in between clogs or joints.

1. Plug the machine into a properly grounded outlet. Leaving the motor in the OFF position.
-

# BrassCraft®

- Loosen thumbscrew and pull sufficient cable out of the drum and place the end of the cable as far into the inlet as possible. The machine should be NO MORE THAN 2' from the drain opening. With around 4' of uncovered cable between the drain opening and drum opening. This cable should form a slight arch. NEVER FORCE cable down the line. When the cable will not feed further into the drain pipe the cable is probably stuck against an elbow or joint in the pipe or may have reached the clog.

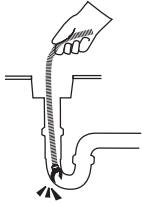

## **⚠ WARNING**

**Do not continue to force cable into the drain pipe. This can cause the cable to twist, buckle, kink or break.**

- Tighten thumbscrew.
- Place the motor in the forward (FOR) position and slowly depress the footswitch to start the machine. The drum will begin to turn as will the cable.
- While depressing the foot switch, apply slight pressure to the top of the arch of cable with both gloved hands. If your cutter is at an elbow, this will help the cutter "jump" the elbow, freeing it to continue through the drain. If your cutter is at the clog, the cable will not feed further.
- Continue steps 2-5 until you have reached your clog.
- Let the cutter do the work. Do not use too much force. **Do not continue to force cable into the drain pipe. This can cause the cable to twist, buckle, kink or break.** Continue applying pressure to the arch of the cable until the cutter has cleared past the clog.

**If the cutter is stuck in the clog, turn the machine into the OFF position, then to REV and slowly press the foot switch. Let the machine run slowly in reverse, stopping the motor often to checking if the cutter has become released, by manually retrieving the cable into the drum. ONLY run the motor in REV if the cutter has become caught. If the cable begins to get stuck or buckle/kink/ twist, immediately remove your foot from the foot switch while firmly holding the cable with both hands. Allow the machine to come to a complete stop and the tension to release from the cable. Turn the machine off and immediately manually rotate the cable in the opposite direction until the twist or buckle has been removed.**

## **⚠ WARNING**

**If drum continues to rotate under power when the cable/cutter is stuck, the cable can twist, buckle, kink or break.**

### Retrieving the Cable

- Move the motor switch to the OFF position. Do not operate the motor in reverse.
- Unplug the power cord.

- Loosen the thumbscrew and hand feed all the cable back into the drum, cleaning in cold water then oiling the cable as you go. It is recommended that the cable is continuously flushed through with clean water and oiled as it is being retrieved from the pipe and again before putting it away. This will prolong cable life and prevent unpleasant odors as well as the damaging effects of drain cleaning compounds.
- Once all of the cable is fed back into the drum, tighten the thumbscrew.

### Post-Operation Maintenance

- Drain water from drum. Your model is equipped with a drain hole in the cable drum. Water, sediment and debris can corrode cable – remove the drum from the machine (see "To Remove Drum from Frame" below) and place it face down to allow all the water to drip out. This should be done after every use.

## MACHINE MAINTENANCE

### **⚠ WARNING**

**The motor switch should be OFF and machine unplugged prior to performing any maintenance, adjusting, or cleaning the machine to reduce the risk of electric shock, fire, serious injury or death.**

### Cables

- The metal cable should be thoroughly cleaned with water and lubricated to prolong cable life and prevent unpleasant odors as well as the damaging effects of sediment and drain cleaning compounds. Cleaning and lubricating should occur prior to storing the machine. Regularly inspect cables for damage.
- Replace cables that are worn or kinked.

### Cleaning the Drum Machine

- This machine is equipped with a drain hole in the cable drum. It is recommended prior to storage, all water residues should be removed from the drum. Remove the drum from the machine (see "To Remove Drum from Frame" below) and place it face down. This will allow all of the water to drip out. Confirm the drum is dry prior to storing.

### Lubrication

The cable will need to be lubricated after each use.

### Storage

Store machine in a dry, safe, secured place, out of the reach of children and people unfamiliar with this machine.

## To Remove Drum from Frame



figure 1

1. Remove wing nuts on the belt guard (pulley wheel cover) and remove the belt guard. (See figure 1)



figure 2

2. Remove the drive belt from the drum by pressing down firmly on the spring motor housing and release the drive belt. (See figure 2)



figure 3

3. A release hook is situated immediately behind the drum. Pull this hook upward and pull the drum forward to remove it from the frame. (See figure 3)

## To Connect the Drum to the Frame



figure 4

1. Place center of drum hub on drum drive. Pull the release hook up to securely push the drum on the frame. (See figure 4)



figure 5

3. Push the motor housing downward to locate the belt onto the pulley wheel. (See figure 5)
4. Reinstall belt guard and wing nuts.

## Replacing Belt Guard/Belt Installation



figure 6

1. Remove wing nuts on the belt guard (pulley wheel cover) and remove the belt guard. (See figure 6)
2. Slide the belt under and over the drum and onto the pulley wheel.



figure 7

3. Push the motor housing downward to locate the belt onto the pulley wheel. (See figure 7)
4. Reinstall belt guard and wing nuts.

## REPAIRING YOUR DRUM MACHINE

### **⚠ WARNING**

General maintenance and other tasks detailed in this manual, such as the replacement of the cable or a damaged belt guard can be done by a qualified owner. **Other servicing repairs, such as the replacement of a defective motor switch, must only be done by BrassCraft. Please contact BrassCraft Customer Service at 877-319-3757.**

### **⚠ WARNING**

When servicing, use only identical replacement parts. **Use of other parts potentially resulting in electric shock/serious injury or death.**

### Installing Replacement Cable

1. Ensure the motor switch should be OFF and machine unplugged.
2. Loosen the thumbscrew and remove existing cable from the machine.
3. Disconnect secured cable end from inside drum unit.
4. Carefully remove the new cable from the packaging. The tension is likely built up and has potential to strike the user.
5. Uncoil the new cable completely.
6. Carefully insert the cable into the drum and reconnect the cable to the inside drum unit for a counter-clockwise insertion.
7. Once cable is secured in drum, continue to insert the remaining cable counterclockwise until you reach the slotted end. This part should remain on the outside of the drum.
8. Finally, tighten the thumbscrew.

**BrassCraft®**

651-BC3020  
v1019