

# VEVOR

**Affordable. Reliable. Home Improvement.**

## **TOOL CART**

**MODEL: ETT02**

Technical Support and E-Warranty Certificate  
[www.vevor.com/support](http://www.vevor.com/support)

# VEVOR

Affordable. Reliable. Home Improvement.





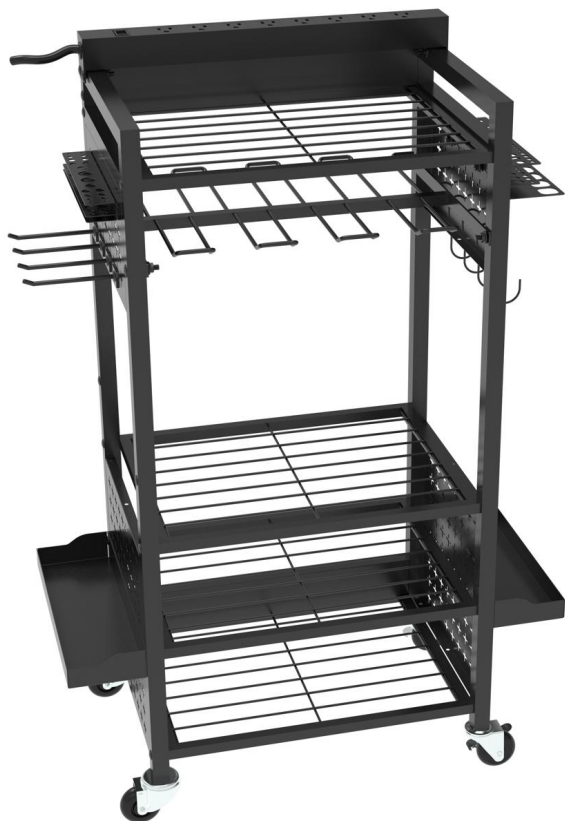





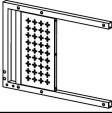

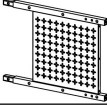

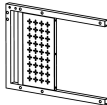

## TOOL CART

**MODEL: ETT02**

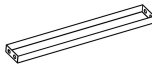

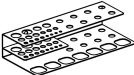
This is the original instruction, please read all manual instructions carefully before operating. VEVOR reserves a clear interpretation of our user manual. The appearance of the product shall be subject to the product you received. Please forgive us that we won't inform you again if there are any technology or software updates on our product.

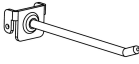
# ASSEMBLY PARTS LIST

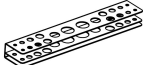
Number	Description	Qty	Number	Description	Qty
①	Left upper plate 	1	⑩	Casters with locks 	2
②	Lower assembly 	2	⑪	Casters without locks 	2
③	Right upper plate 	1	⑫	wrench 	1
④	Reticulated plate 	4	⑬	M6x35 screw 	32
⑤	Hanging panel 	1	⑭	M6x10 screw 	8
⑥	Dam-board 	2	⑮	nut 	20
⑦	Screw holder 	1	⑯	electrical socket outlet 	1
⑧	Hole hook 	4	⑰	Side frame 	2
⑨	Pothead 	4	⑱	Screwdriver head holder 	1

## Safety Tips:

1. Lay a soft cloth or paper on the floor before assembly to prevent the floor from scratching the parts.

2. Before installation, remove the protective rubber caps of the left and right upper components, as shown in the right picture.
3. The maximum load of each layer after assembly is 45 LBS.
4. The items on each layer should be evenly distributed.

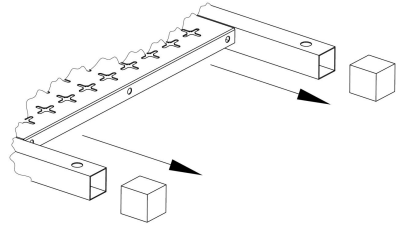

**Note: During installation, do not tighten the screws until all parts are installed.**

**Step1**

Connect Part “①” and Part “②” with screw “⑭”.

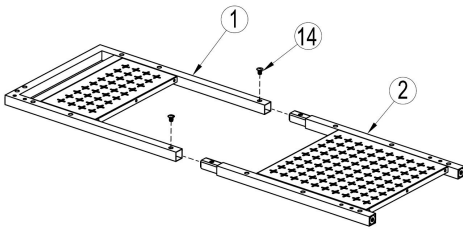

**Step2**

Connect Part “③” and Part “②” with screw “⑭”.

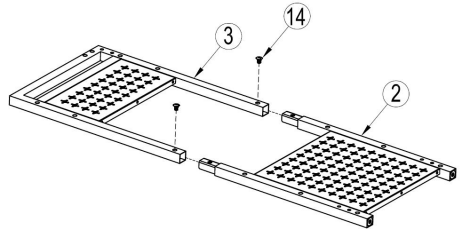

**Step3**

Attach parts “④” and “⑰” onto the assembled “①” and “②” with screw “⑬”.

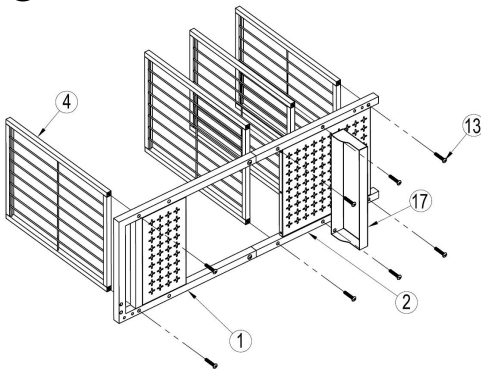

**Step4**

Attach Part “⑤” to the assembly with screws “⑬” and nuts “⑮”.

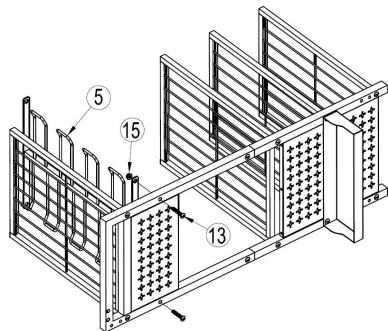

### Step5

Attach part “(6)” to the assembly with screws “(13)” and nuts “(15)”.

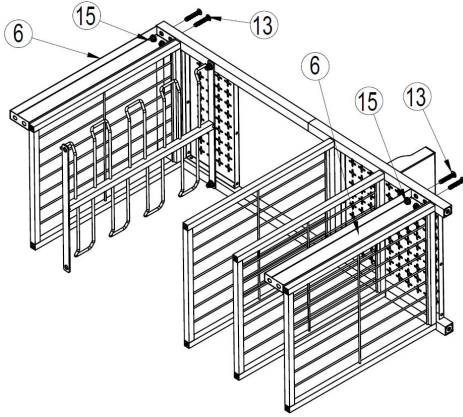

### Step6

Repeat Steps 3-5 to connect the installation kit in Step 2 to the installation component.

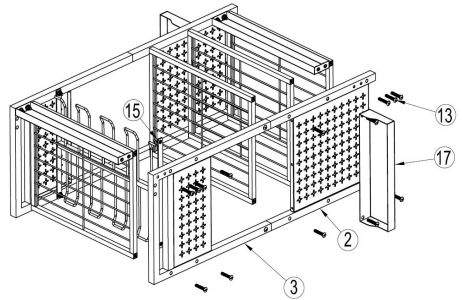

### Step7

Attach part “(7)” to the assembly with screws “(14)” and nuts “(15)”.

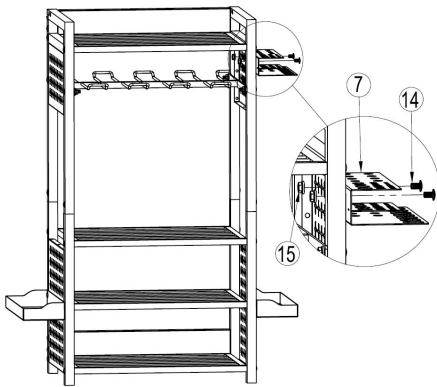

### Step8

Attach part “(18)” to the assembly with screws “(14)” and nuts “(15)”.

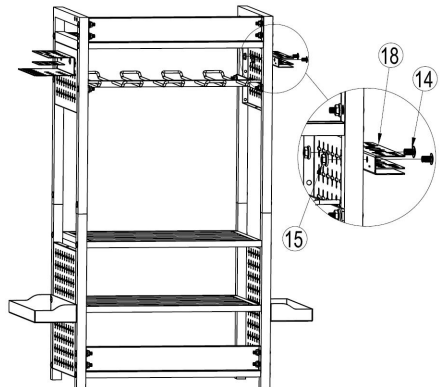

### Step9

Install casters “10” and “11” onto the assembly with wrench “12”.

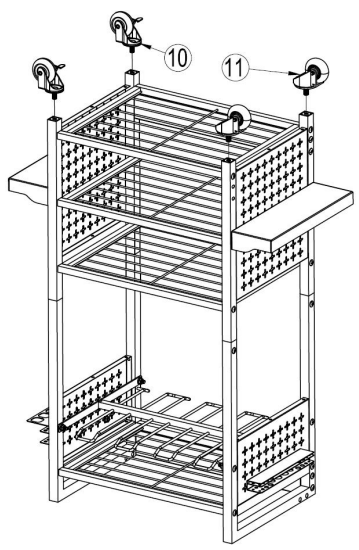

### Step10

Attach part “16” to the assembly with screws “13” and nuts “15”.

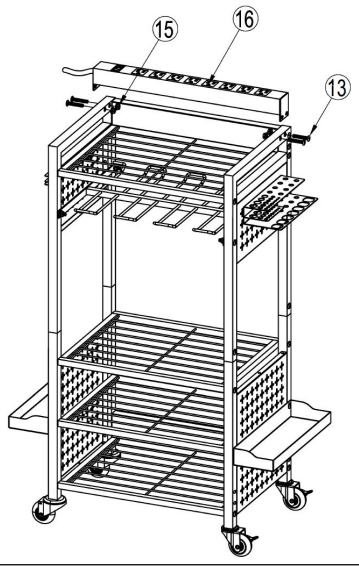

### Step11

Install part “8” on the assembly as shown.

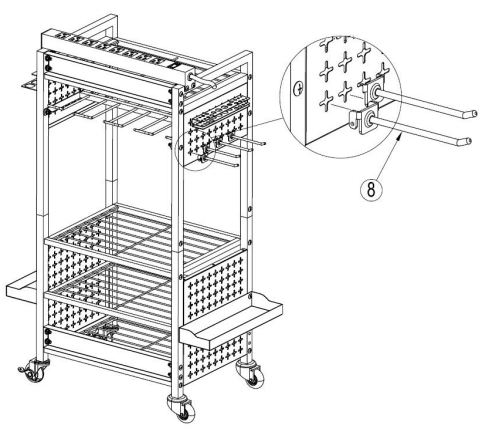

### Step12

Install part “9” on the assembly as shown.

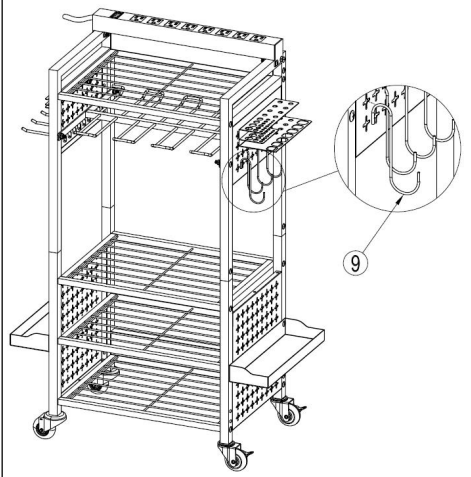

## Installation complete

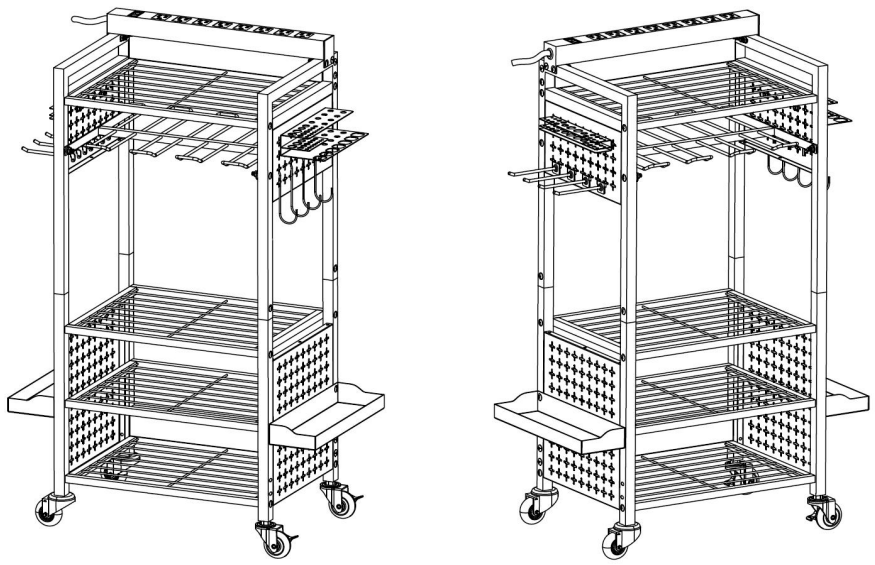

## PARAMETER

MODEL	ETT02
Cart body size	420*300*865 mm
Total load limit	150 lbs
Power Socket type	BY213-P08
Power Socket Rating	15A 125V 60Hz Max.1875W

**Manufacturer:** Shanghaimuxinmuyeyouxiangongsi

**Address:** Shuangchenglu 803nong11hao1602A-1609shi, baoshanqu, shanghai 200000 CN.

**Imported to AUS:** SIHAO PTY LTD. 1 ROKEVA STREETEASTWOOD NSW 2122 Australia

**Imported to USA:** Sanven Technology Ltd. Suite 250, 9166 Anaheim Place, Rancho Cucamonga, CA 91730

<b>UK</b>	<b>REP</b>
-----------	------------

YH CONSULTING LIMITED. C/O YH Consulting Limited Office 147, Centurion House, London Road, Staines-upon-Thames, Surrey, TW18 4AX

<b>EC</b>	<b>REP</b>
-----------	------------

E-CrossStu GmbH  
Mainzer Landstr.69,  
60329 Frankfurt am Main.



**Technical Support and E-Warranty Certificate**  
[www.vevor.com/support](http://www.vevor.com/support)

# VEVOR

**Affordable. Reliable. Home Improvement.**

## CHARIOT À OUTILS

MODÈLE: ETT02

Assistance technique et certificat de garantie électronique  
[www.vevor.com/support](http://www.vevor.com/support)

# VEVOR

Affordable. Reliable. Home Improvement.





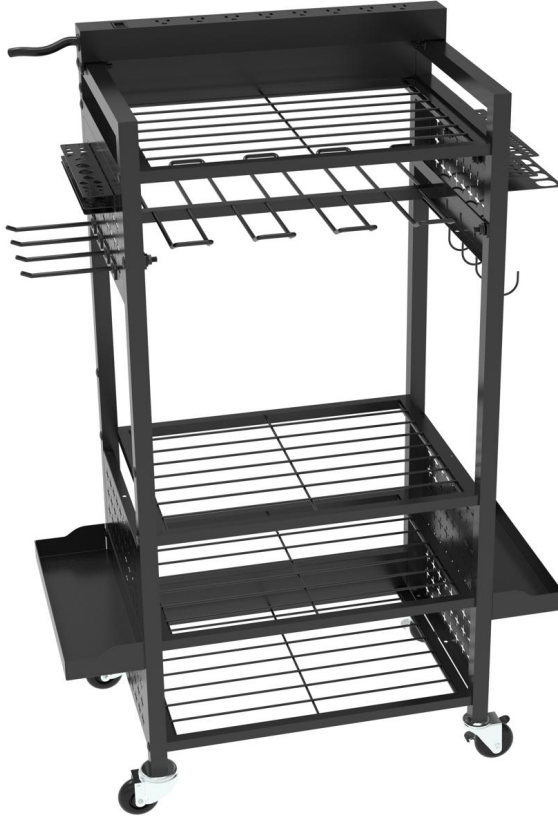

## TOOL CART



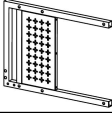
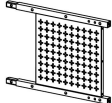
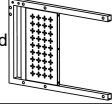

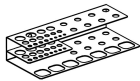
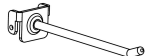

MODÈLE: ETT02



Il s'agit de la notice d'utilisation d'origine. Veuillez lire attentivement toutes les instructions du manuel avant de l'utiliser. VEVOR se réserve le droit d'interpréter clairement notre manuel d'utilisation. L'apparence du produit dépend du produit que vous avez reçu. Veuillez nous excuser, nous ne vous informerons plus si des mises à jour technologiques ou logicielles sont disponibles sur notre produit.

# LISTE DES PIÈCES D'ASSEMBLAGE

Nombre	Description	Qté y
①	Plaque supérieure 	1
②	Ensemble inférieur 	2
③	Plaque supérieure d 	1
④	Plaque réticulée 	4
⑤	Panneau susper ' 	1
⑥	Panneau de d 	2
⑦	Support de vis 	1
⑧	Crochet à trou 	4
⑨	Pothos 	4

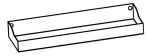
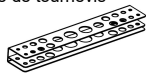
Nombre	Description	Qté y
⑩	Roulettes avec blocage 	2
⑪	Roulettes sans blocage 	2
⑫	clé 	1
⑬	M6x35 vis 	32
⑭	M6x10 vis 	8
⑮	noix 	20
⑯	prise de courant électrique 	1
⑰	Cadre latéral 	2
⑱	Support de tête de tournevis 	1

## Conseils de sécurité :

4. Posez un chiffon doux ou du papier sur le sol avant l'assemblage pour éviter que le sol ne rayer les pièces.

5. Avant l'installation, retirez les capuchons de protection en caoutchouc du composants supérieurs gauche et droit , comme indiqué sur l'image de droite .

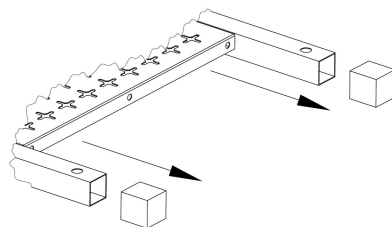

6. La charge maximale de chaque couche après assemblage est de 45 LBS.

4. Les éléments de chaque couche doivent être répartis uniformément.

**Remarque : lors de l'installation, ne serrez pas les vis tant que toutes les pièces ne sont pas installées .**

### Étape 1

Connectez la partie « ① » et la partie « ② » avec la vis « ⑭ » .

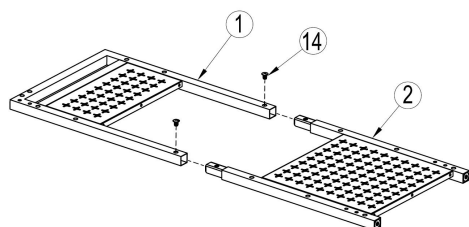

### Étape 2

Connectez la partie « ③ » et la partie « ② » avec la vis « ⑭ » .

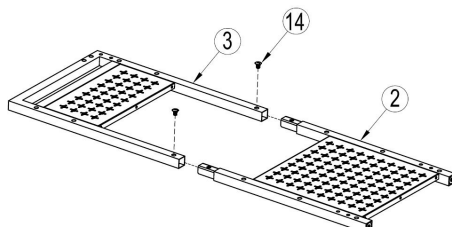

### Étape 3

Fixez les pièces « ④ » et « ⑰ » sur le assemblé « ① » et « ② » avec la

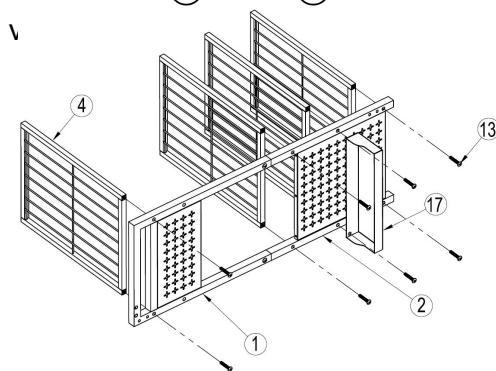

### Étape 4

Fixez la pièce « ⑤ » à l' assemblage avec les vis « ⑬ » et

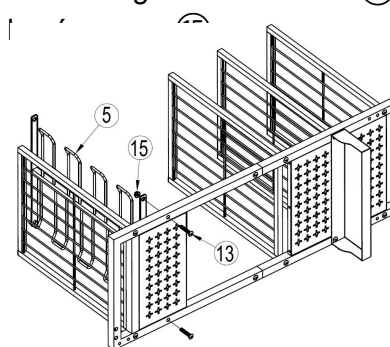

### Étape 5

Fixez la pièce « ⑥ » à l'assemblage avec les vis « ⑬ » et les écrous « ⑮ » .

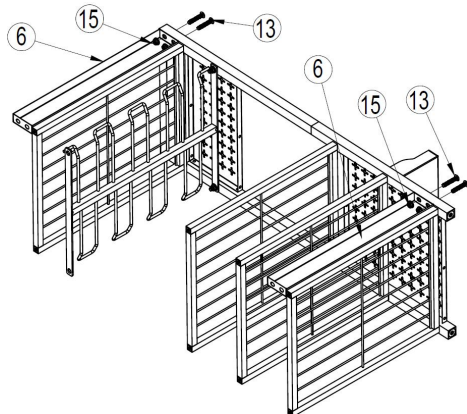

### Étape 6

Répétez les étapes 3 à 5 pour connecter le kit d'installation de l'

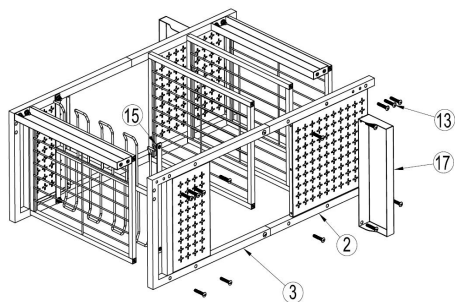

### Étape 7

Fixez la pièce « ⑦ » à l'

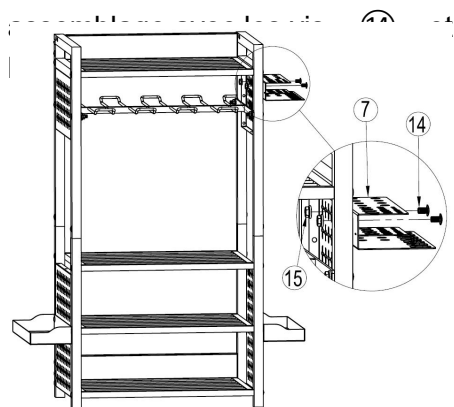

### Étape 8

Fixez la pièce « ⑱ » à l'

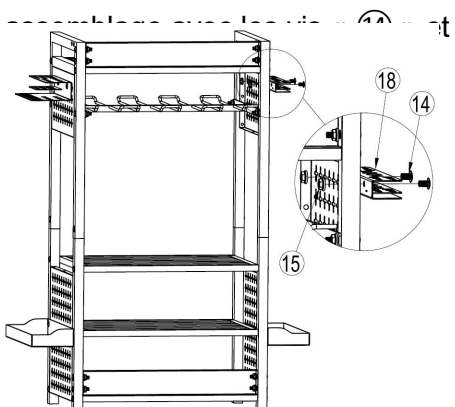

### Étape 9

Installez les roulettes « ⑩ » et « ⑪ » sur l' assemblage avec la clé « ⑫ » .

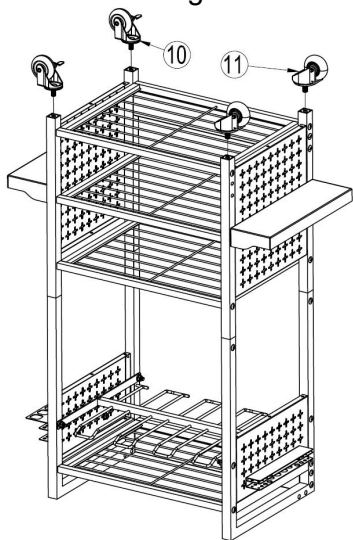

### Étape 10

Fixez la pièce « ⑯ » à l' » et les

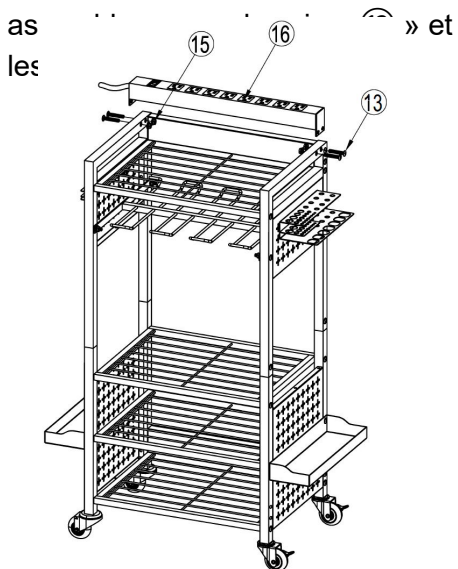

### Étape 11

Installez la pièce « ⑧ » sur l' assemblage comme indiqué .

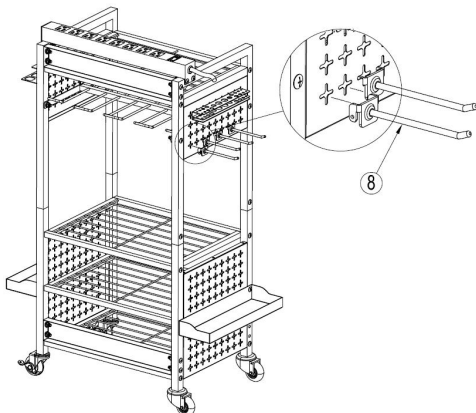

### Étape 12

Installez la pièce « ⑨ » sur l' assemblage comme indiqué .

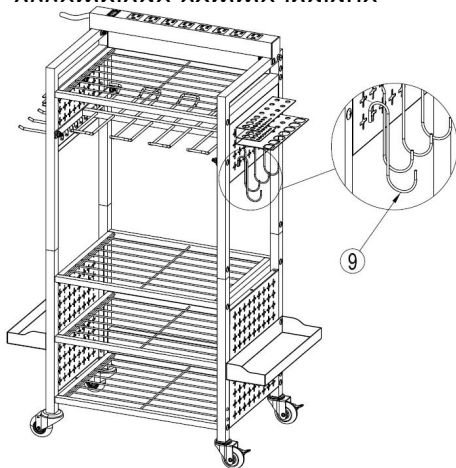

## Installation terminée

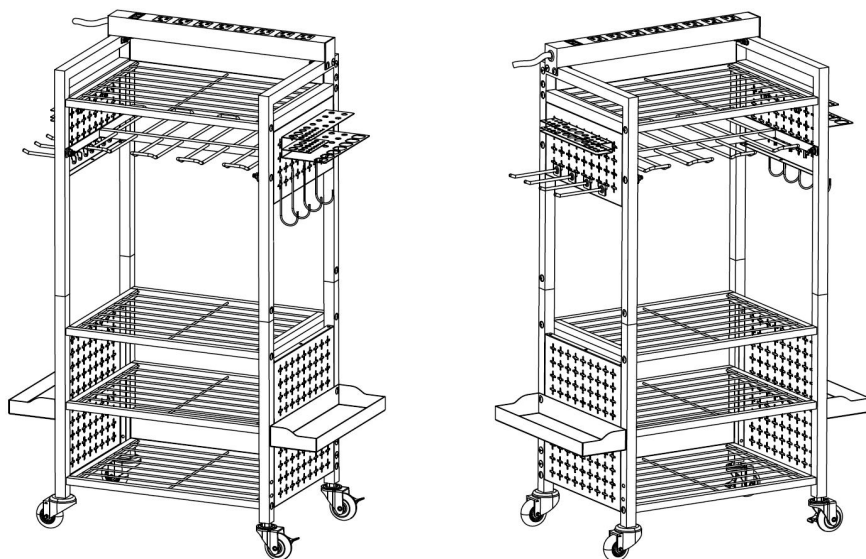

## PARAMÈTRE

MODÈLE	ETT0 2
Taille du corps du chariot	42 0*3 0 0*8 65 mm
Limite de charge totale	1 5 0 livres
Type de prise de courant	BY213-P08
Puissance nominale de la prise	15A 125V 60Hz Max.1875W

**Fabricant** : Shanghaimuxinmuyeyouxiangongsi

**Adresse** : Shuangchenglu 803nong11hao1602A-1609shi, baoshanqu, Shanghai 200 000 CN.

**Importé en Australie** : SIHAO PTY LTD. 1 ROKEVA

STREETEASTWOOD

NSW 2122 Australie

**Importé aux États-Unis** : Sanven Technology Ltd. Suite 250, 9166 Anaheim

Lieu, Rancho Cucamonga, CA 91730

<b>UK</b>	<b>REP</b>
-----------	------------

YH CONSULTING LIMITED. C/O YH Consulting Limited Office 147, Centurion House, London Road, Staines-upon-Thames, Surrey, TW18 4AX

<b>EC</b>	<b>REP</b>
-----------	------------

E-CrossStu GmbH  
Mainzer Landstr.69,  
60329 Frankfurt am Main.



**Assistance technique et certificat de garantie électronique**  
[www.vevor.com/support](http://www.vevor.com/support)

# VEVOR

**Affordable. Reliable. Home Improvement.**

## **WERKZEUGWAGEN**

**MODELL: ETT02**



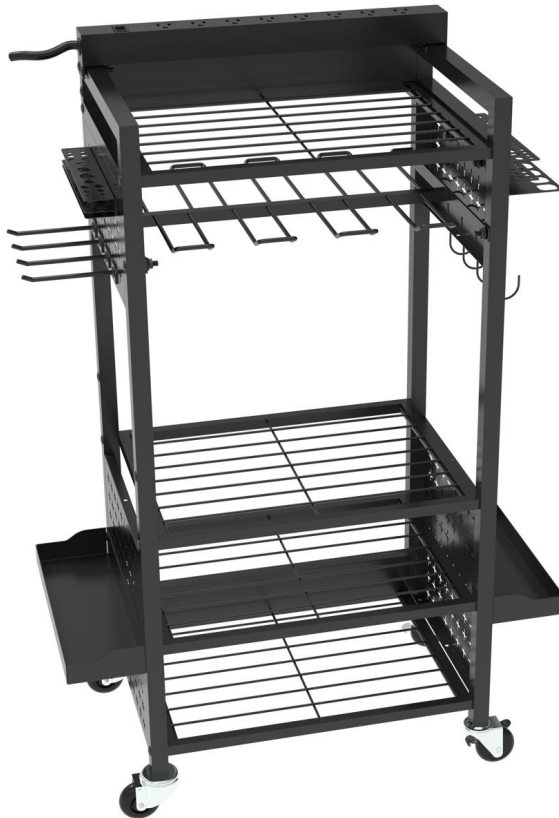

Technischer Support und E-Garantie-Zertifikat  
[www.vevor.com/support](http://www.vevor.com/support)





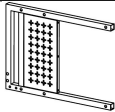
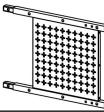
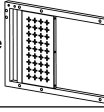

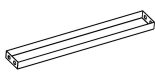
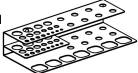
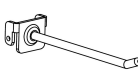
**MODELL: ETT02**



Dies ist die Originalanleitung. Bitte lesen Sie alle Anweisungen sorgfältig durch, bevor Sie das Gerät in Betrieb nehmen. VEVOR behält sich eine klare Auslegung unserer Bedienungsanleitung vor. Das Erscheinungsbild des Produkts richtet sich nach dem Produkt, das Sie erhalten haben. Bitte verzeihen Sie uns, dass wir Sie nicht erneut informieren, wenn es Technologie- oder Software-Updates für unser Produkt gibt .

# MONTAGETEILELISTE

Nummer	Beschreibung	Menge y
①	Linke obere Platte 	1
②	Untere Baugruppe 	2
③	Rechte obere Platte 	1
④	Retikulierte Platte 	4
⑤	Hängeplatte 	1
⑥	D am-Board 	2
⑦	Schraubenhalter 	1
⑧	Lochhaken 	4
⑨	Haken 	4
Nummer	Beschreibung	Menge y
⑩	Rollen mit Feststeller 	2

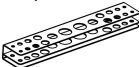
⑪	Rollen ohne Feststeller 	2
⑫	Schlüssel 	1
⑬	M6x35 schraube 	32
⑭	M6x10 schrauben 	8
⑮	Nuss 	20
⑯	elektrische Steckdose 	1
⑰	Seitenrahmen 	2
⑱	Schraubendreherkopfhalter 	1

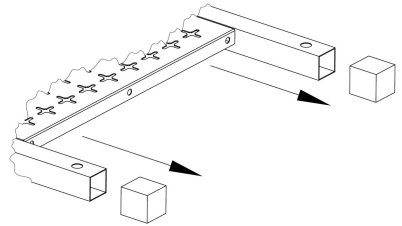

### Sicherheitstipps:

7. Legen Sie vor der Montage ein weiches Tuch oder Papier auf den Boden, um zu verhindern, dass der Boden die Teile verkratzen.

8. Vor dem Einbau die Gummischutzkappen der linke und rechte obere Komponente , wie im rechten Bild gezeigt .

9. Die maximale Belastung jeder Schicht nach der Montage beträgt 20,4 kg.

4. Die Gegenstände auf jeder Ebene sollten gleichmäßig verteilt sein.

**Hinweis: Bei der Montage die Schrauben erst festziehen, wenn alle Teile montiert sind .**

### Schritt 1

Verbinden Sie Teil „ ① “ und Teil „ ② “ mit der Schraube „ ⑭ “ .

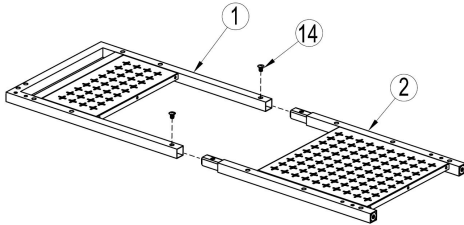

### Schritt 2

Verbinden Sie Teil „ ③ “ und Teil „ ② “ mit der Schraube „ ⑭ “ .

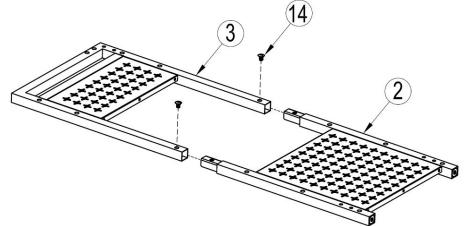

### Schritt 3

Befestigen Sie die Teile „ ④ “ und „ ⑭ “ an der „ ① “ und „ ② “ mit Schraube „ ⑬ “

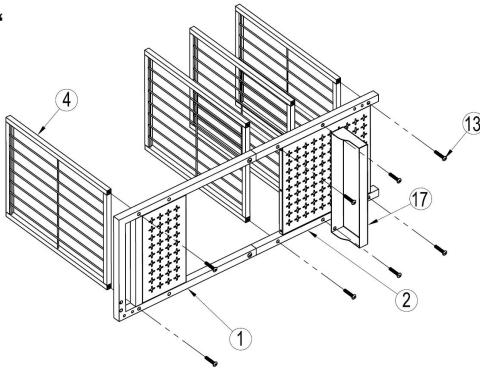

### Schritt 4

Befestigen Sie Teil „ ⑤ “ mit Schrauben „ ⑬ “ und Muttern „ ⑮ “ an der Baugruppe .

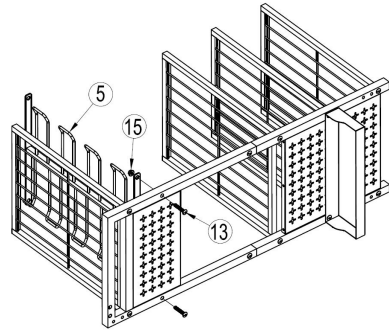

### Schritt 5

Befestigen Sie Teil „ ⑥ “ mit Schrauben „ ⑬ “ und Muttern „ ⑮ “ an der Baugruppe .

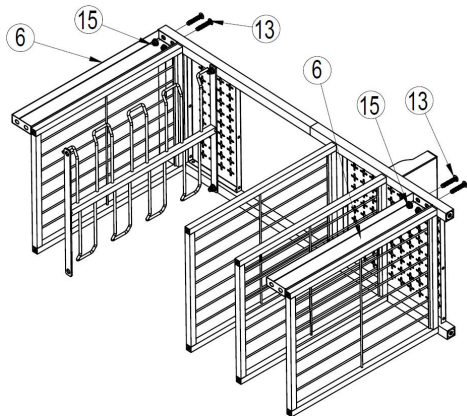

### Schritt 6

Wiederholen Sie die Schritte 3 bis 5, um das Installationskit aus Schritt 2 mit der Installationskomponente zu

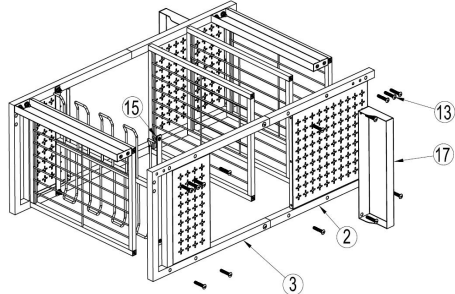

### Schritt 7

Befestigen Sie Teil „ ⑦ “ mit Schrauben „ ⑭ “ und Muttern „ ⑮ “

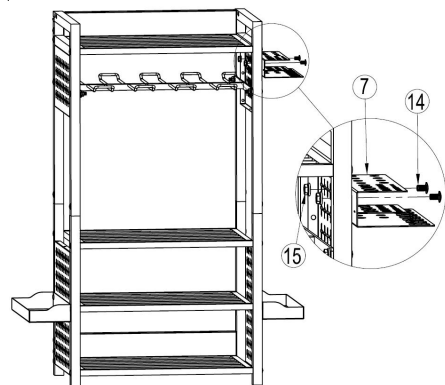

### Schritt 8

Befestigen Sie Teil „ ⑱ “ mit Schrauben „ ⑭ “ und Muttern „ ⑮ “ an der Baugruppe

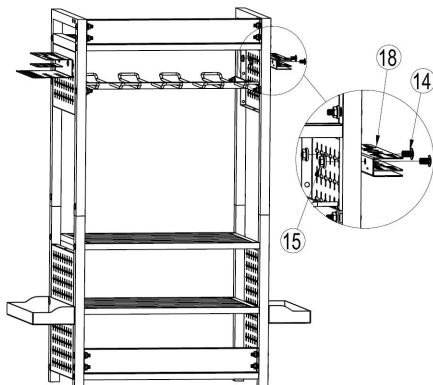

### Schritt 9

Montieren Sie die Rollen „ ⑩ “ und „ ⑪ “ mit dem Schraubenschlüssel „ ⑫ “ an der Baugruppe .

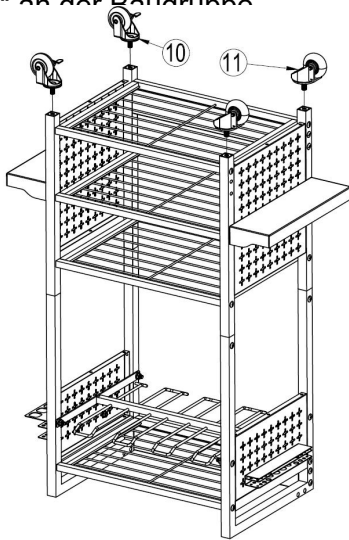

### Schritt 10

Befestigen Sie Teil „ ⑬ “ mit Schrauben „ ⑭ “ und Muttern „ ⑮ “ an der Baugruppe .

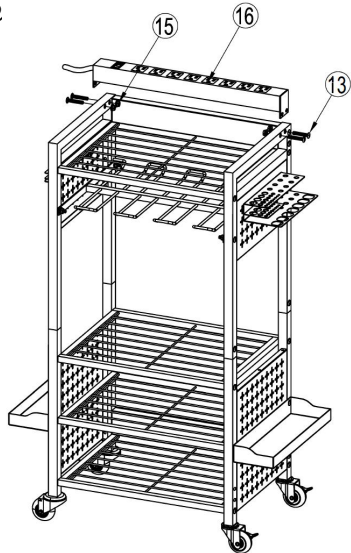

### Schritt 11

Montieren Sie Teil „ ⑧ “ wie gezeigt an der Baugruppe .

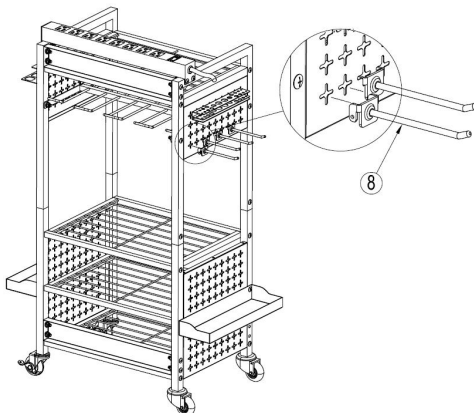

### Schritt 12

Montieren Sie Teil „ ⑨ “ wie gezeigt an der Baugruppe .

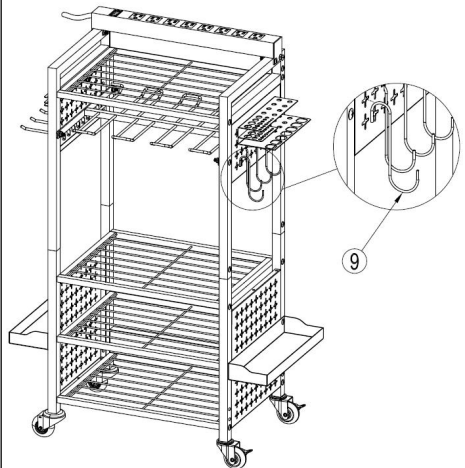

## Installation abgeschlossen

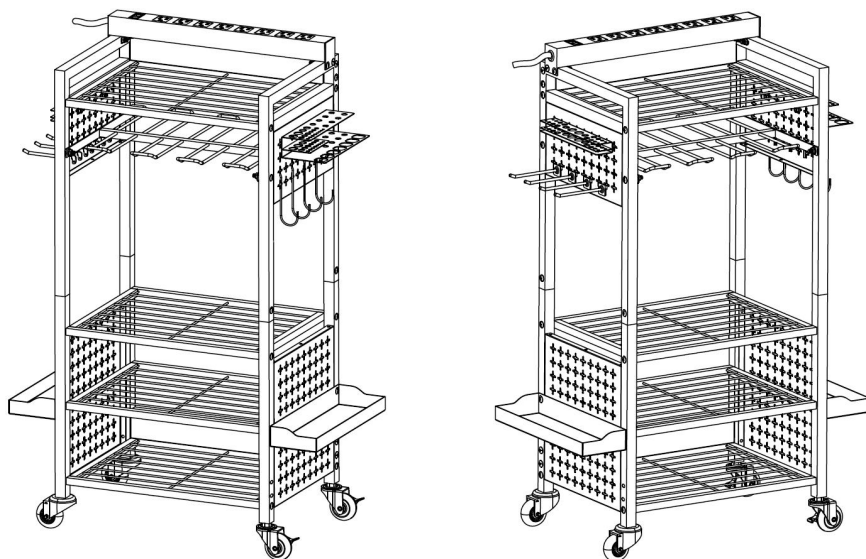

## PARAMETER

MODELL	ETT0 2
Wagenkörpergröße	42 0*3 0 0*8 65 mm
Gesamtbelastungsgrenze	1 5 0 Pfund
Steckdosentyp	BY213-P08
Nennleistung der Steckdose	15 A, 125 V, 60 Hz, max. 1875 W

**Hersteller:** Shanghai muxinmuyeyouxiangongsi

**Adresse:** Shuangchenglu 803nong11hao1602A-1609shi, baoshanqu, Shanghai, 200.000 CN.

**Nach AUS importiert:** SIHAO PTY LTD. 1 ROKEVA

STREETEASTWOOD

NSW 2122 Australien

**Importiert in die USA:** Sanven Technology Ltd. Suite 250, 9166 Anaheim Ort, Rancho Cucamonga, CA 91730

<b>UK</b>	<b>REP</b>
-----------	------------

YH CONSULTING LIMITED. C/O YH Consulting Limited Office 147, Centurion House, London Road, Staines-upon-Thames, Surrey, TW18 4AX

<b>EC</b>	<b>REP</b>
-----------	------------

E-CrossStu GmbH  
Mainzer Landstr.69,  
60329 Frankfurt am Main.



**Technischer Support und E-Garantie-Zertifikat**  
[www.vevor.com/support](http://www.vevor.com/support)

# VEVOR

**Affordable. Reliable. Home Improvement.**

## **CARRELLO PORTAUTENSILI**

**MODELLO: ETT02**

Supporto tecnico e certificato di garanzia elettronica  
[www.vevor.com/support](http://www.vevor.com/support)

# VEVOR

Affordable. Reliable. Home Improvement.





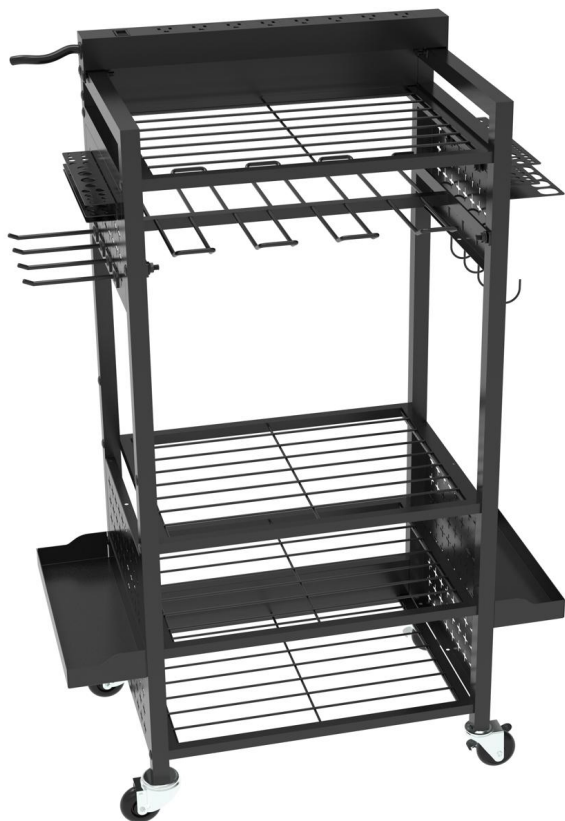

## TOOL CART



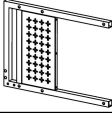
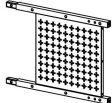
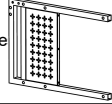

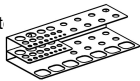
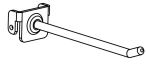

**MODELLO: ETT02**



Questa è l'istruzione originale, si prega di leggere attentamente tutte le istruzioni del manuale prima di utilizzare. VEVOR si riserva una chiara interpretazione del nostro manuale utente. L'aspetto del prodotto sarà soggetto al prodotto ricevuto. Vi preghiamo di perdonarci se non vi informeremo di nuovo se ci sono aggiornamenti tecnologici o software sul nostro prodotto.

# ELENCO DELLE PARTI DI MONTAGGIO

Numero	Descrizione	Quantità
①	Piastra superiore s 	1
②	Gruppo inferiore 	2
③	Piastra superiore de 	1
④	Piastra reticolata 	4
⑤	Pannello sospes 	1
⑥	D sono-consig" 	2
⑦	Supporto per vit 	1
⑧	Gancio forato 	4
⑨	Gancio a gancio 	4
Numero	Descrizione	Quantità
⑩	Ruote con bloccaggio 	2

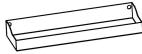
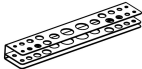
⑪	Ruote senza blocco 	2
⑫	chiave 	1
⑬	M6x35 vite 	32
⑭	M6x10 vite 	8
⑮	noce 	20
⑯	presa elettrica 	1
⑰	Telaio laterale 	2
⑱	Supporto per testa di cacciavite 	1

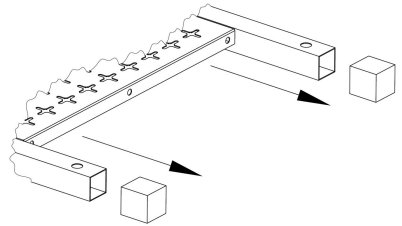

### Suggerimenti per la sicurezza:

10. Prima del montaggio, stendere un panno morbido o della carta sul pavimento per evitare che il pavimento si sposti.

graffiando le parti.

11. Prima dell'installazione, rimuovere i cappucci protettivi in gomma dei componenti superiori sinistro e destro, come mostrato nell'immagine a destra.

12. Il carico massimo di ogni strato dopo il montaggio è di 45 libbre.

4. Gli elementi su ogni strato devono essere distribuiti uniformemente.

**Nota: durante l'installazione, non stringere le viti finché tutte le parti non sono installate.**

### Passo 1

Collegare la parte “ ① ” e la parte “ ② ” con la vite “ ⑭ ” .

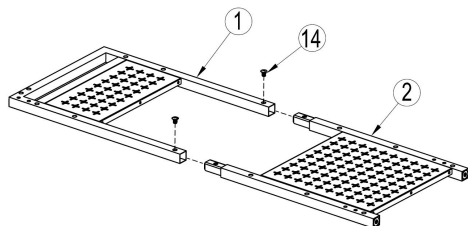

### Passo 2

Collegare la parte “ ③ ” e la parte “ ② ” con la vite “ ⑭ ” .

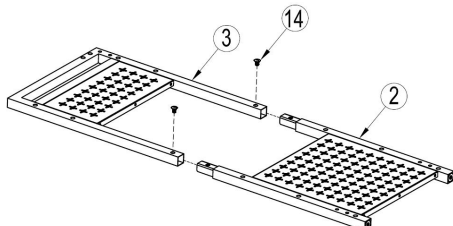

### Passo 3

Fissare le parti “ ④ ” e “ ⑰ ” sul  
assemblati “ ① ” e “ ② ” con vite  
“ ⑬ ” .

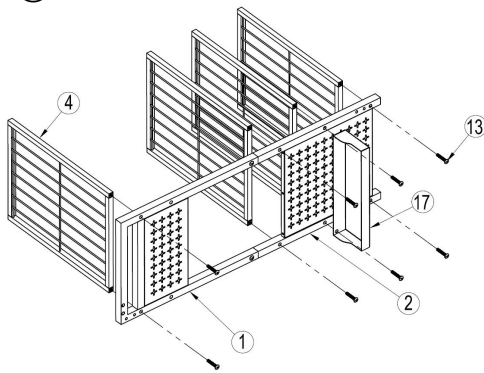

### Passo 4

Fissare la parte “ ⑤ ” all'insieme  
con le viti “ ⑬ ” e i dadi “ ⑮ ” .

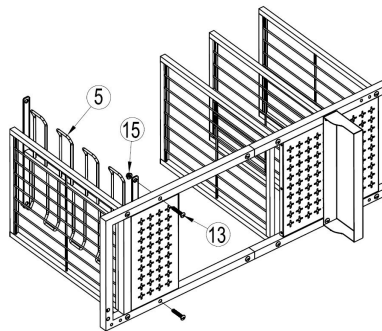

### Passo 5

Fissare la parte " ⑥ " all'assieme con le viti " ⑬ " e i dadi " ⑮ " .

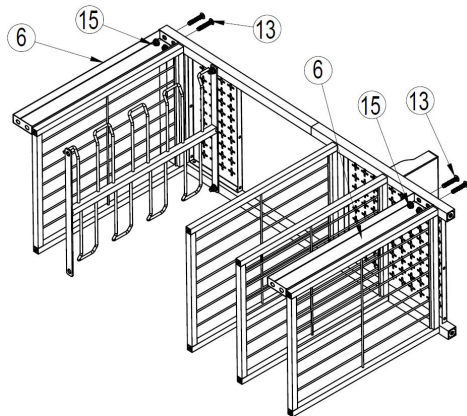

### Passo 6

Ripetere i passaggi da 3 a 5 per collegare il kit di installazione nel passaggio 2 al componente di installazione.

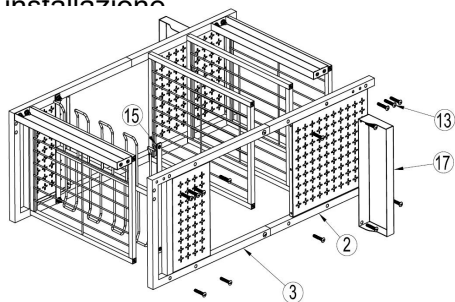

### Passo 7

Fissare la parte " ⑦ " all'assieme con le viti " ⑭ " e i dadi " ⑮ " .

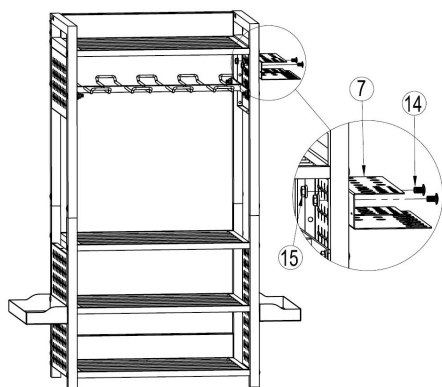

### Passo 8

Fissare la parte " ⑱ " al gruppo con le viti " ⑭ " e i dadi " ⑮ " .

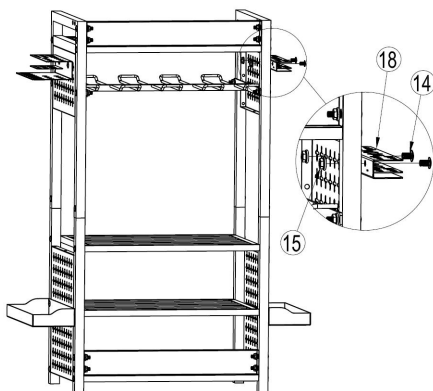

### Passo 9

Installare le rotelle “ 10 ” e “ 11 ” sul gruppo con la chiave “ 12 ” .

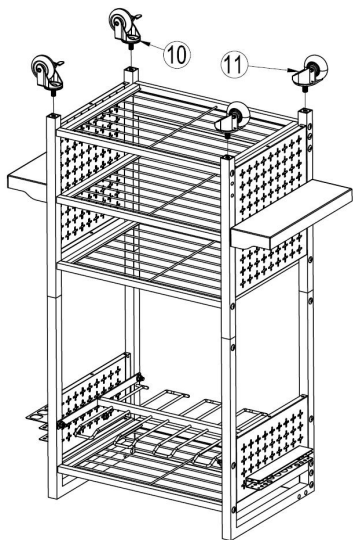

### Passo 10

Fissare la parte “ 16 ” al gruppo con le viti “ 13 ” e i dadi “ 15 ” .

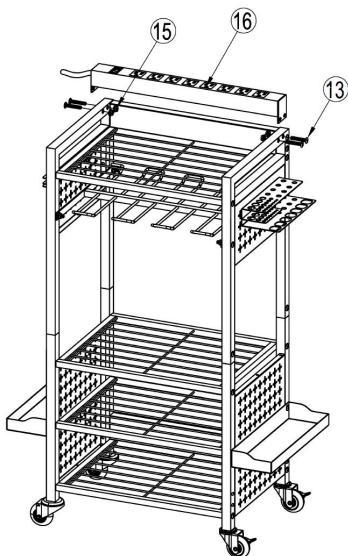

### Passo 11

Installare la parte “ 8 ” sul gruppo come mostrato .

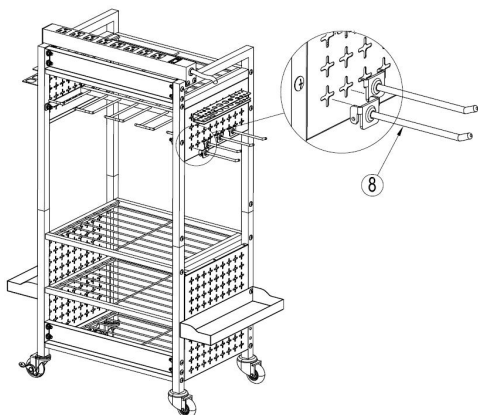

### Passo 12

Installare la parte “ 9 ” sul gruppo come mostrato .

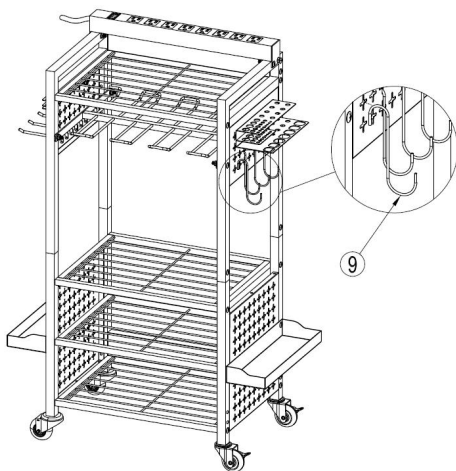

## Installazione completata

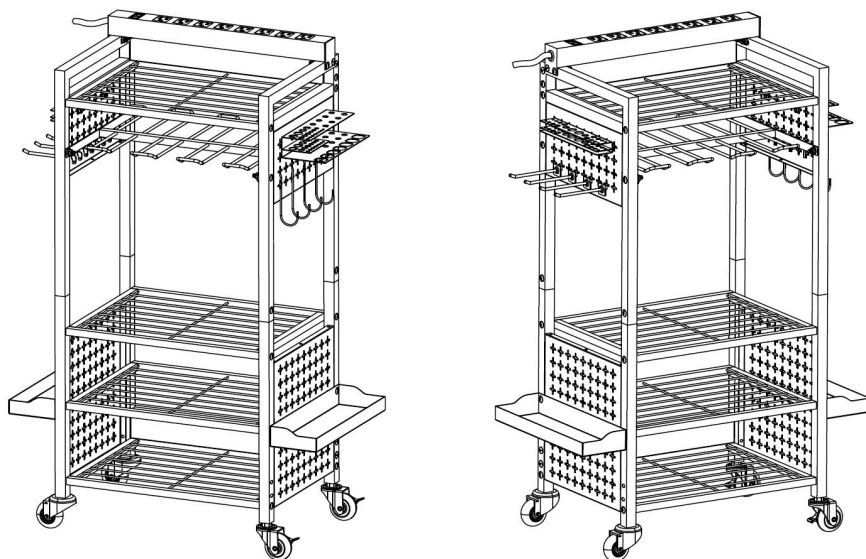

## PARAMETRO

MODELLO	ET02
Dimensioni del corpo del carrello	42 0*3 0 0*8 65 mm
Limite di carico totale	1 5 0 libbre
Tipo di presa di corrente	Codice articolo: BY213-P08
Valutazione della presa di corrente	15A 125V 60Hz Max.1875W

**Produttore:** Shanghaimuxinmuyeyouxiangongsi

**Indirizzo:** Shuangchenglu 803nong11hao1602A-1609shi, baoshanqu, shanghai 200000 CN.

**Importato in AUS:** SIHAO PTY LTD. 1 ROKEVA STREETEASTWOOD  
Nuovo Galles del Sud 2122 Australia

**Importato negli USA:** Sanven Technology Ltd. Suite 250, 9166 Anaheim  
Luogo, Rancho Cucamonga, CA 91730



YH CONSULTING LIMITED. C/O YH Consulting  
Limited Office 147, Centurion House, London  
Road, Staines-upon-Thames, Surrey, TW18 4AX



E-CrossStu GmbH  
Mainzer Landstr.69,  
60329 Frankfurt am Main.



**Supporto tecnico e certificato di garanzia elettronica**  
[www.vevor.com/support](http://www.vevor.com/support)

# VEVOR

**Affordable. Reliable. Home Improvement.**

## **CARRITO DE HERRAMIENTAS**

**MODELO: ETT02**

Soporte técnico y certificado de garantía electrónica  
[www.vevor.com/support](http://www.vevor.com/support)

# VEVOR

Affordable. Reliable. Home Improvement.





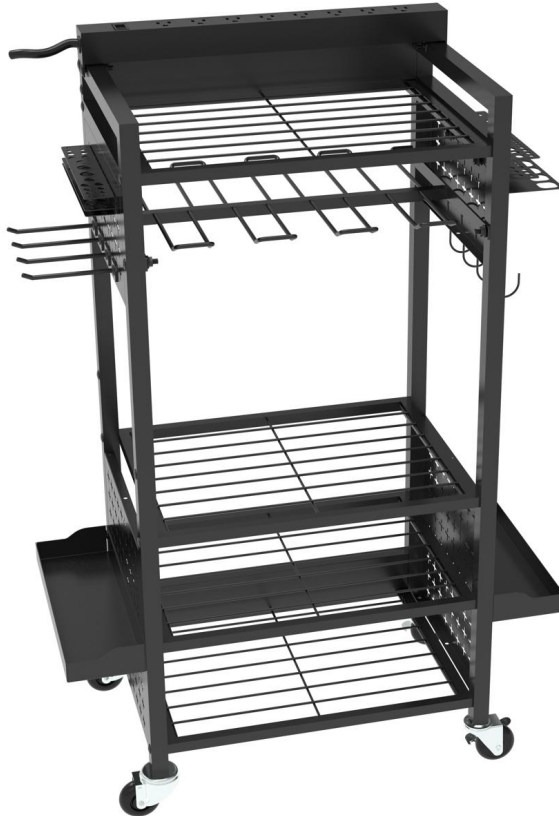

## TOOL CART



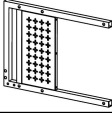
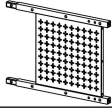
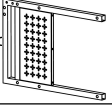

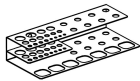
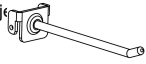

MODELO: ETT02



Estas son las instrucciones originales, lea atentamente todas las instrucciones del manual antes de utilizar el producto. VEVOR se reserva una interpretación clara de nuestro manual de usuario. La apariencia del producto estará sujeta al producto que recibió. Perdónenos por no informarle nuevamente si hay actualizaciones de tecnología o software en nuestro producto.

## LISTA DE PIEZAS DE MONTAJE

Número	Descripción	Cantidad y
①	Placa superior izq 	1
②	Conjunto inferior 	2
③	Placa superior derec 	1
④	Placa reticulada 	4
⑤	Panel colgante 	1
⑥	de la presa 	2
⑦	Porta tornillos 	1
⑧	Gancho de aguj 	4
⑨	Ganchillo 	4
Número	Descripción	Cantidad y
⑩	Ruedas con frenos 	2

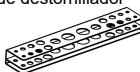
11	Ruedas sin frenos 	2
12	llave inglesa 	1
13	M6x35 tornillo 	32
14	M6x10 tornillo 	8
15	tuerca 	20
16	toma de corriente eléctrica 	1
17	Marco lateral 	2
18	Portacabezas de destornillador 	1

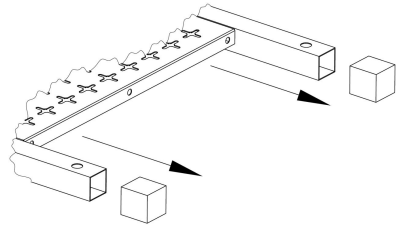

### Consejos de seguridad:

13. Coloque un paño suave o papel en el suelo antes del montaje para evitar que el suelo se deslice.

rayando las piezas.

14. Antes de la instalación, retire las tapas protectoras de goma del Componentes superiores izquierdo y derecho , como se muestra en la imagen de la derecha .

15. La carga máxima de cada capa después del ensamblaje es de 45 LBS.

4. Los elementos de cada capa deben estar distribuidos uniformemente.

**Nota: Durante la instalación, no apriete los tornillos hasta que todas las piezas estén instaladas .**

### Paso 1

Conecte la parte “ ① ” y la parte “ ② ” con el tornillo “ ⑭ ” .

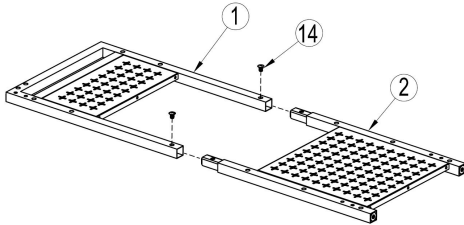

### Paso 2

Conecte la parte “ ③ ” y la parte “ ② ” con el tornillo “ ⑭ ” .

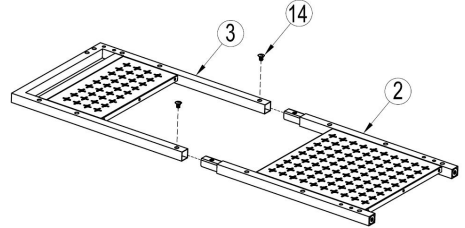

### Paso 3

Coloque las piezas “ ④ ” y “ ⑰ ” en el ensamblado “ ① ” y “ ② ” con t

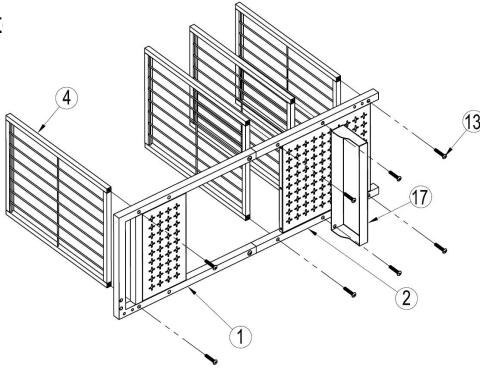

### Paso 4

Fije la pieza “ ⑤ ” al conjunto con los tornillos “ ⑬ ” y las tuercas “ ⑮ ” .

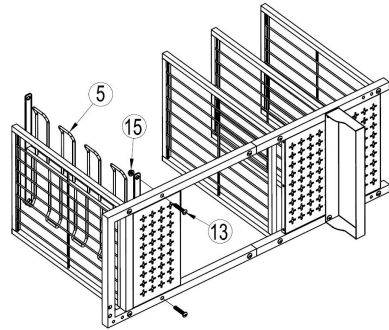

### Paso 5

Fije la pieza “ ⑥ ” al conjunto con los tornillos “ ⑬ ” y las tuercas “ ⑮ ”.

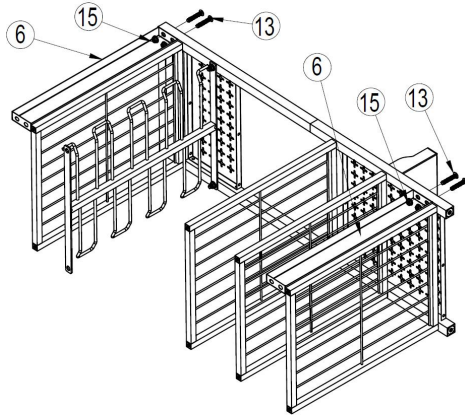

### Paso 6

Repita los pasos 3 a 5 para conectar el kit de instalación del paso 2 al componente de instalación.

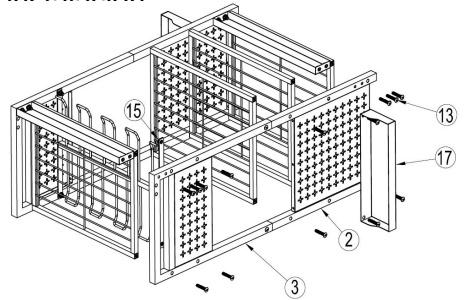

### Paso 7

Fije la pieza “ ⑦ ” al conjunto con los tornillos “ ⑭ ” y las tuercas “ ⑮ ”.

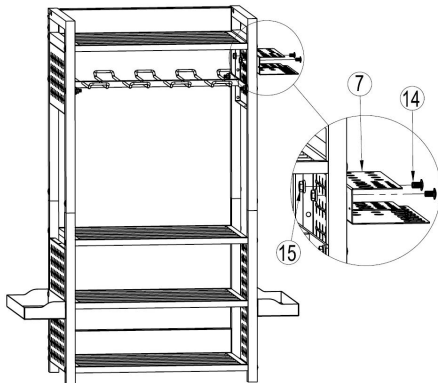

### Paso 8

Fije la pieza “ ⑱ ” al conjunto con los tornillos “ ⑭ ” y las tuercas “ ⑮ ”.

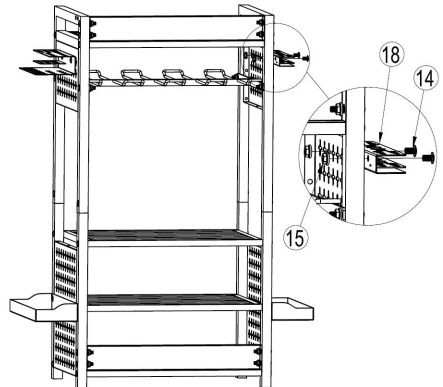

### Paso 9

Instale las ruedas “ 10 ” y “ 11 ” en el conjunto con la llave “ 12 ” .

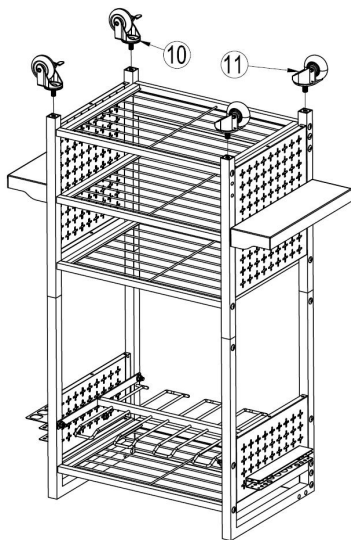

### Paso 10

Fije la pieza “ 16 ” al conjunto con los tornillos “ 13 ” y las tuercas “ 15 ” .

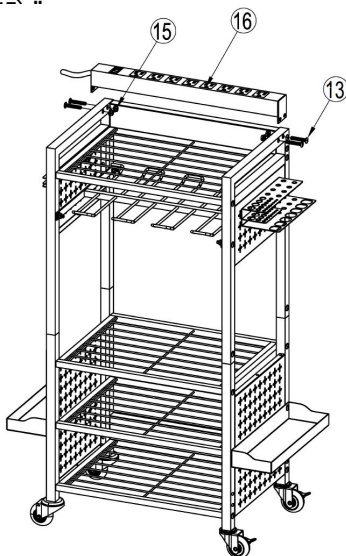

### Paso 11

Instale la pieza “ 8 ” en el conjunto como se muestra .

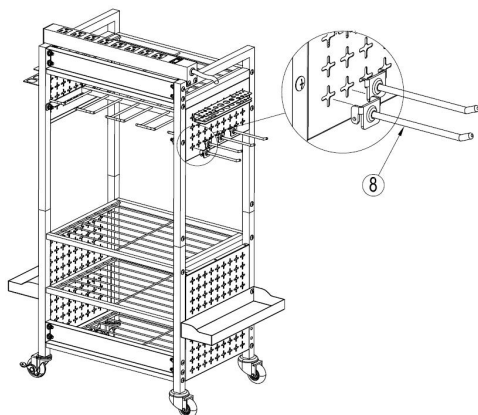

### Paso 12

Instale la pieza “ 9 ” en el conjunto como se muestra .

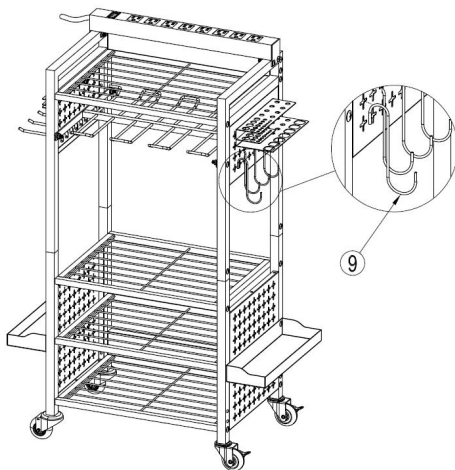

## Instalación completa

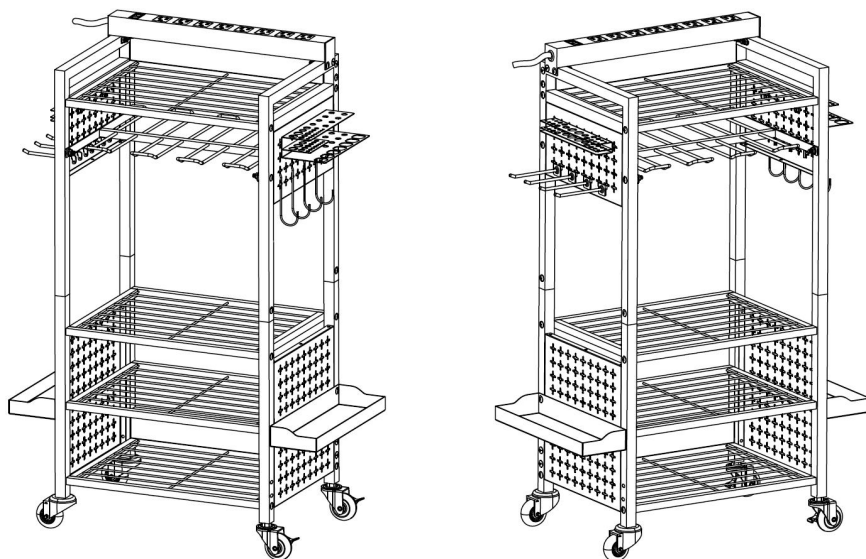

## PARÁMETRO

MODELO	ETT0 2
Tamaño del cuerpo del carro	42 0*3 0 0*8 65 mm
Límite de carga total	1 5 0 libras
Tipo de toma de corriente	BY213-P08
Clasificación de la toma de corriente	15 A, 125 V, 60 Hz, máx. 1875 W

**Fabricante:** Shanghaimuxinmuyeyouxiangongsi

**Dirección:** Shuangchenglu 803nong11hao1602A-1609shi, baoshanqu, Shanghai 200000 CN.

**Importado a Australia:** SIHAO PTY LTD. 1 ROKEVA STREETEASTWOOD

Nueva Gales del Sur 2122 Australia

**Importado a EE. UU.:** Sanven Technology Ltd. Suite 250, 9166 Anaheim Lugar, Rancho Cucamonga, CA 91730

<b>UK</b>	<b>REP</b>
-----------	------------

YH CONSULTING LIMITED. C/O YH Consulting Limited Office 147, Centurion House, London Road, Staines-upon-Thames, Surrey, TW18 4AX

<b>EC</b>	<b>REP</b>
-----------	------------

E-CrossStu GmbH  
Mainzer Landstr.69,  
60329 Frankfurt am Main.



**Soporte técnico y certificado de garantía electrónica**  
[www.vevor.com/support](http://www.vevor.com/support)

# VEVOR

**Affordable. Reliable. Home Improvement.**

## **WÓZEK NARZĘDZIOWY**

**MODEL: ETT02**

Wsparcie techniczne i certyfikat e-gwarancji  
[www.vevor.com/support](http://www.vevor.com/support)

# VEVOR

Affordable. Reliable. Home Improvement.





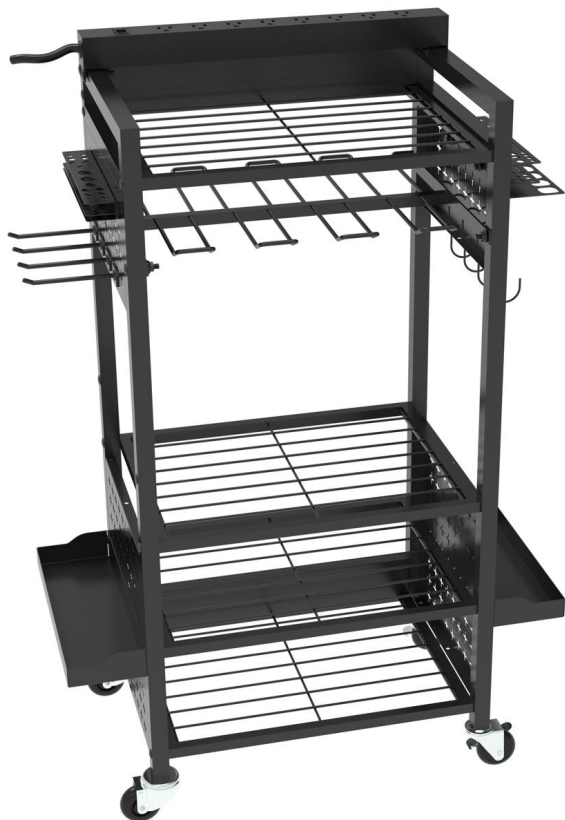

## TOOL CART



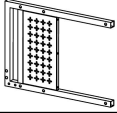
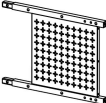
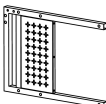

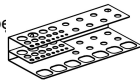
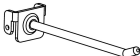

**MODEL: ETT02**



To jest oryginalna instrukcja, przed użyciem należy uważnie przeczytać wszystkie instrukcje. VEVOR zastrzega sobie jasną interpretację naszej instrukcji obsługi. Wygląd produktu będzie zależał od produktu, który otrzymałeś. Prosimy o wybaczenie, że nie poinformujemy Cię ponownie, jeśli w naszym produkcie pojawią się jakiegokolwiek aktualizacje technologiczne lub oprogramowania.

# LISTA CZĘŚCI MONTAŻOWYCH

Numer	Opis	Ilość y
①	Lewa górna płyta 	1
②	Dolny montaż 	2
③	Prawa górna płyta 	1
④	Płyta siatkowa 	4
⑤	Panel wiszący 	1
⑥	D am-board 	2
⑦	Uchwyt na śrubę 	1
⑧	Hak z otworem 	4
⑨	Hak 	4

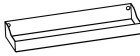
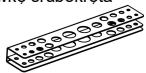
Numer	Opis	Ilość y
⑩	Kółka z blokadą 	2
⑪	Kółka bez blokad 	2
⑫	klucz 	1
⑬	M6x35 śruba 	32
⑭	M6x10 śruba 	8
⑮	nakrętka 	20
⑯	gniazdo elektryczne 	1
⑰	Rama boczna 	2
⑱	Uchwyt na główkę śrubokręta 	1

## Wskazówki dotyczące bezpieczeństwa:

16. Przed montażem połóż na podłodze miękką szmatkę lub papier, aby zapobiec jej zamoczeniu.  
zarysowując części.

17. Przed montażem należy zdjąć ochronne gumowe zaślepki lewy i prawy górny element , jak pokazano na prawym obrazku .

18. Maksymalne obciążenie każdej warstwy po złożeniu wynosi 45 funtów.

4. Elementy na każdej warstwie powinny być równomiernie rozłożone.

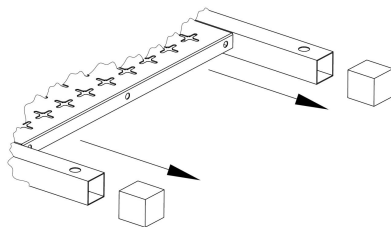

**Uwaga: Podczas montażu nie dokręcaj śrub, dopóki wszystkie części nie zostaną zamontowane .**

### Krok 1

Połącz część „ ① ” i część „ ② ” za pomocą śruby „ ⑭ ” .

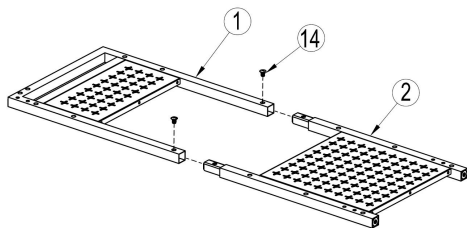

### Krok 2

Połącz część „ ③ ” i część „ ② ” za pomocą śruby „ ⑭ ” .

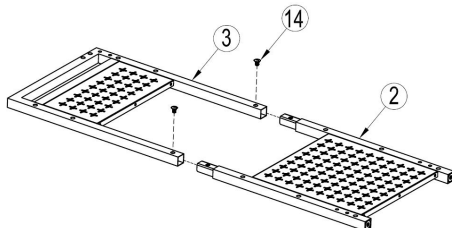

### Krok 3

Zamontuj części „ ④ ” i „ ⑰ ” na zmontowane „ ① ” i „ ② ” ze śrubą „ ⑬ ” .

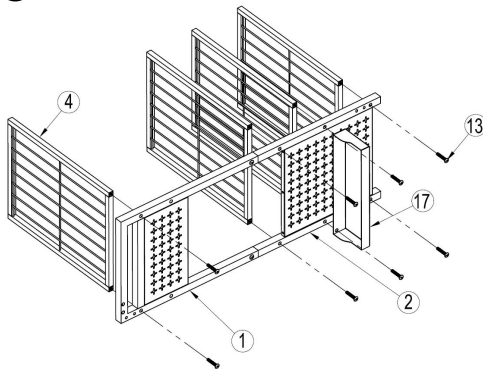

### Krok 4

Przymocuj część „ ⑤ ” do zespołu za pomocą śrub „ ⑬ ” i nakrętek „ ⑮ ” .

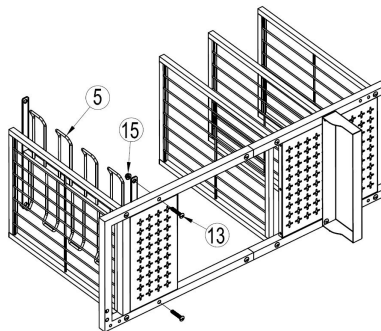

### Krok 5

Przymocuj część „ ⑥ ” do zespołu za pomocą śrub „ ⑬ ” i nakrętek „ ⑮ ”.

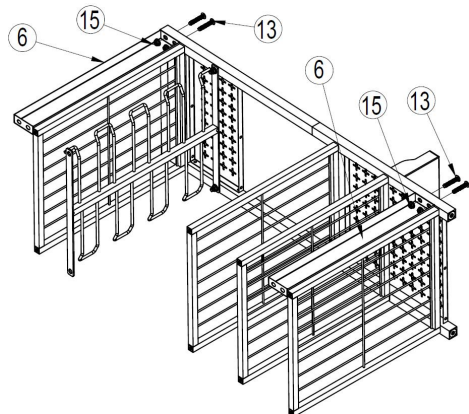

### Krok 6

Powtórz kroki 3 - 5, aby podłączyć zestaw instalacyjny z kroku 2 do podzespołu instalacyjnego.

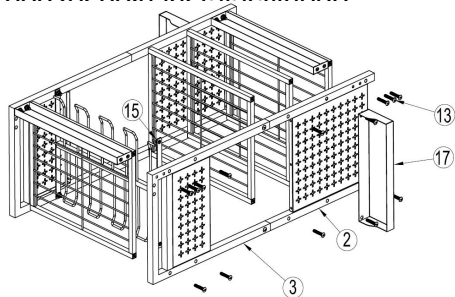

### Krok 7

Przymocuj część „ ⑦ ” do zespołu za pomocą śrub „ ⑭ ” i nakrętek „ ⑮ ”.

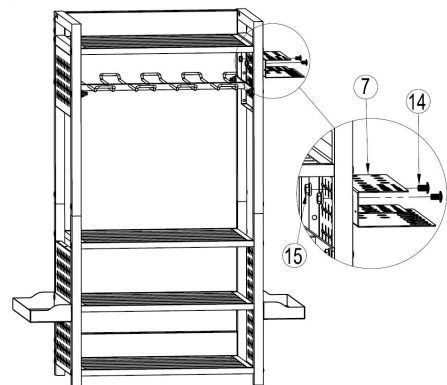

### Krok 8

Przymocuj część „ ⑱ ” do zespołu za pomocą śrub „ ⑭ ” i nakrętek „ ⑮ ”.

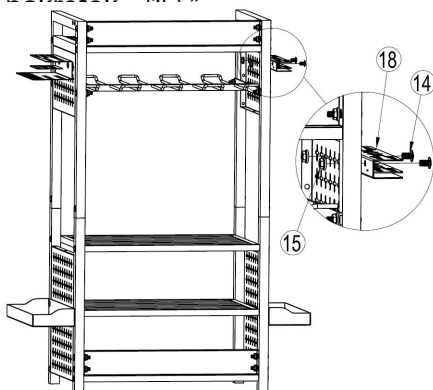

### Krok 9

Zamontuj kółka „ ⑩ ” i „ ⑪ ” na zespole za pomocą klucza „ ⑫ ” .

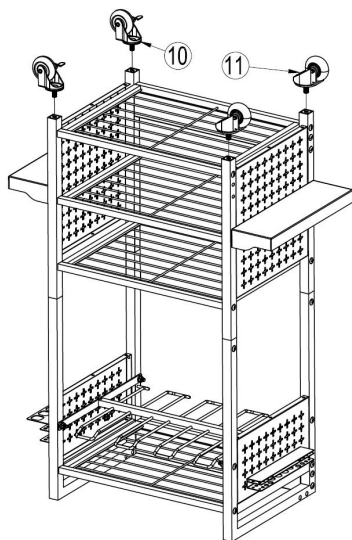

### Krok 10

Przymocuj część „ ⑬ ” do zespołu za pomocą śrub „ ⑬ ” i na

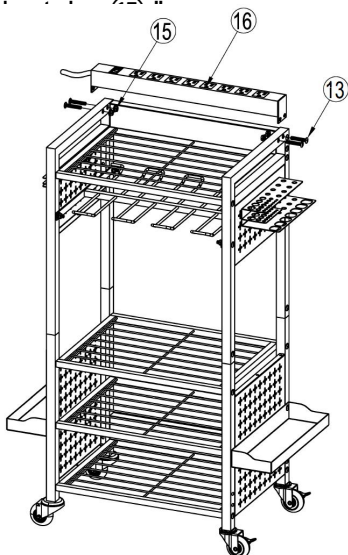

### Krok 11

Zamontuj część „ ⑧ ” na zespole, jak pokazano .

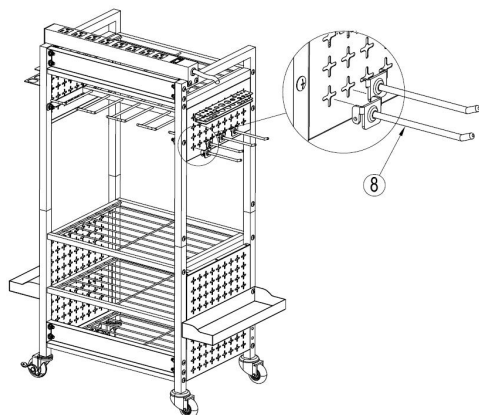

### Krok 12

Zamontuj część „ ⑨ ” na zespole, jak pokazano .

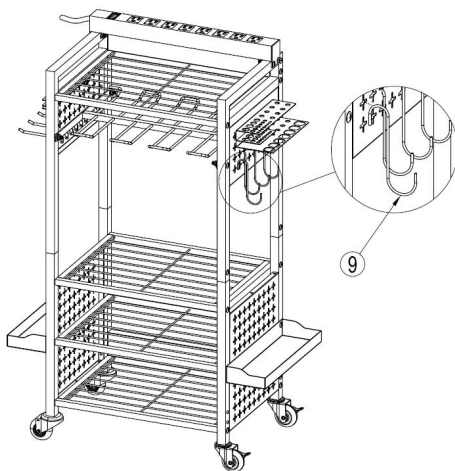

## Instalacja ukończona

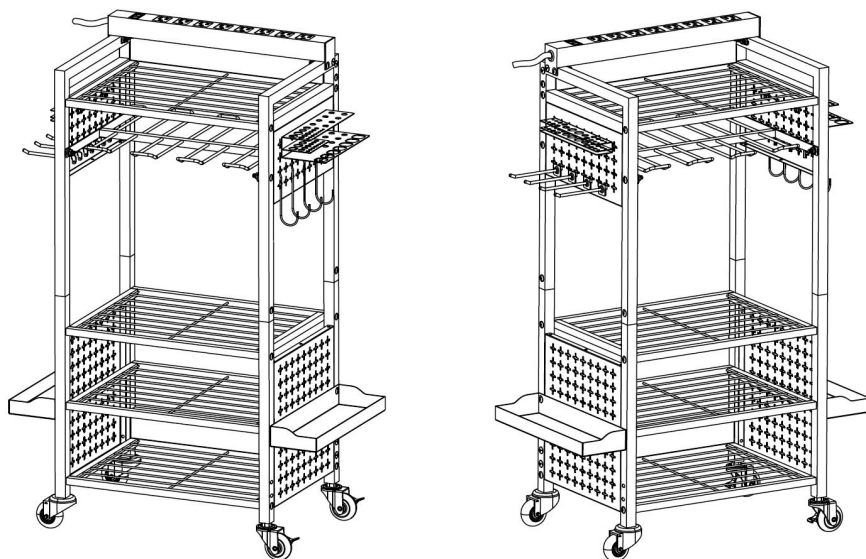

## PARAMETR

MODEL	ETT0 2
Rozmiar korpusu wózka	42 0*3 0 0*8 65 mm
Całkowity limit obciążenia	1 5 0 funtów
Typ gniazda zasilania	BY213-P08
Moc znamionowa gniazda zasilania	15A 125V 60Hz maks. 1875W

**Producent:** Shanghaimuxinmuyeyouxiangongsi

**Adres:** Shuangchenglu 803nong11hao1602A-1609shi, baoshanqu, Szanghaj 200000 CN.

**Importowane do AUS:** SIHAO PTY LTD. 1 ROKEVA

STREETEASTWOOD

NSW 2122 Australia

**Importowane do USA:** Sanven Technology Ltd. Suite 250, 9166 Anaheim Miejsce, Rancho Cucamonga, CA 91730

<b>UK</b>	<b>REP</b>
-----------	------------

YH CONSULTING LIMITED. C/O YH Consulting Limited Office 147, Centurion House, London Road, Staines-upon-Thames, Surrey, TW18 4AX

<b>EC</b>	<b>REP</b>
-----------	------------

E-CrossStu GmbH  
Mainzer Landstr.69,  
60329 Frankfurt am Main.



**Wsparcie techniczne i certyfikat e-gwarancji**

**[www.vevor.com/support](http://www.vevor.com/support)**

# VEVOR

**Affordable. Reliable. Home Improvement.**

## **GEREEDSCHAPSWAGEN**

**MODEL: ETT02**

Technische ondersteuning en e-garantiecertificaat  
[www.vevor.com/support](http://www.vevor.com/support)

# VEVOR

Affordable. Reliable. Home Improvement.



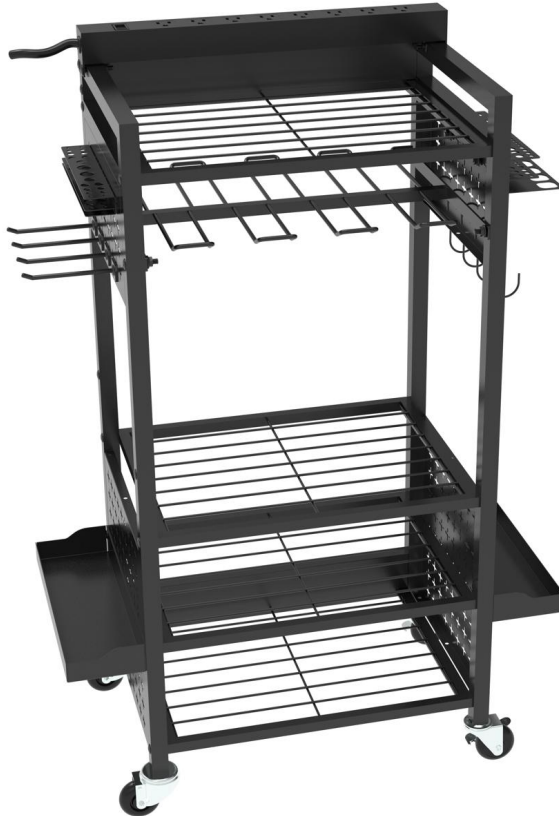

## TOOL CART

**MODEL: ETT02**



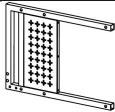
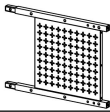
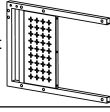

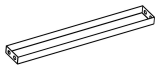
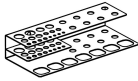
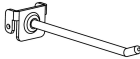

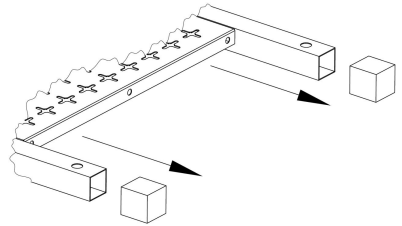

Dit is de originele instructie, lees alle handleidingen zorgvuldig door voordat u het product gebruikt. VEVOR behoudt zich een duidelijke interpretatie van onze gebruikershandleiding voor. Het uiterlijk van het product is afhankelijk van het product dat u hebt ontvangen. Vergeef ons dat we u niet opnieuw zullen informeren als er technologie- of software-updates voor ons product zijn .

# LIJST MET MONTAGEONDERDELEN

Nummer	Beschrijving	Hoeveelheid
①	Linker bovenplaat 	1
②	Onderste montage 	2
③	Rechter bovenplaat 	1
④	Netvormige plaat 	4
⑤	Hangend paneel 	1
⑥	D am-bord 	2
⑦	Schroefhouder 	1
⑧	Gat haak 	4
⑨	Potje 	4
Nummer	Beschrijving	Hoeveelheid
⑩	Wielen met vergrendel 	2

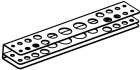

⑪	Wielen zonder vergren 	2
⑫	moersleutel 	1
⑬	M6x35 schroef 	32
⑭	M6x10 schroef 	8
⑮	moer 	20
⑯	stopcontact 	1
⑰	Zijframe 	2
⑱	Schroevendraaierkophouder 	1

### Veiligheidstips:

19. Leg voor de montage een zachte doek of papier op de vloer om te voorkomen dat de vloer nat wordt.

krassen op de onderdelen.

20. Verwijder voor de installatie de beschermende rubberen doppen van de linker

en rechter bovenste componenten , zoals weergegeven in de rechter afbeelding .  
21. De maximale belasting van elke laag na montage bedraagt 45 LBS.  
4. De items op elke laag moeten gelijkmatig verdeeld zijn.

**Let op: Draai de schroeven tijdens de installatie pas vast als alle onderdelen zijn gemonteerd .**

### Stap 1

Verbind onderdeel “ ① ” en onderdeel “ ② ” met schroef “ ⑭ ” .

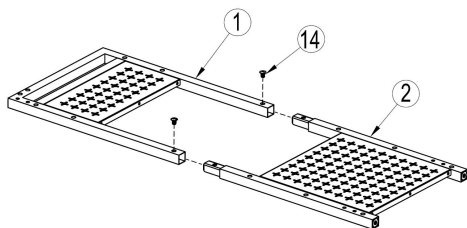

### Stap 2

Verbind onderdeel “ ③ ” en onderdeel “ ② ” met schroef “ ⑭ ” .

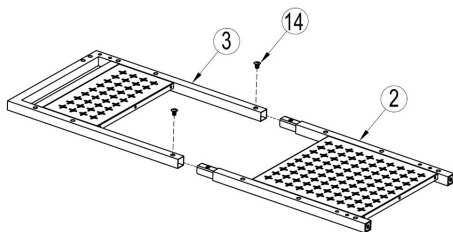

### Stap 3

Bevestig de onderdelen “ ④ ” en “ ⑰ ” op de gemonteerd “ ① ” en “ ② ” met  
ε

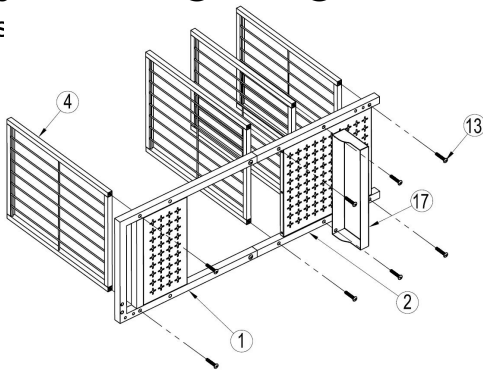

### Stap 4

Bevestig onderdeel “ ⑤ ” aan de constructie met schroeven “ ⑬ ” en moeren “ ⑮ ” .

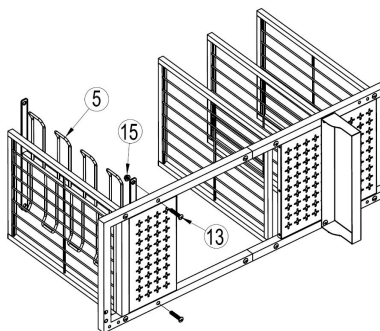

### Stap 5

Bevestig onderdeel " ⑥ " aan de constructie met schroeven " ⑬ " en moeren " ⑮ " .

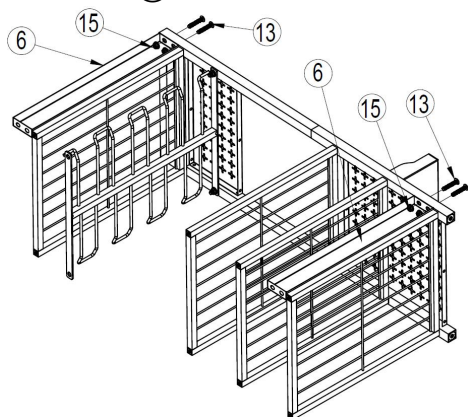

### Stap 6

Herhaal stap 3 t/m 5 om de installatiekit uit stap 2 aan te sluiten op het installatieonderdeel

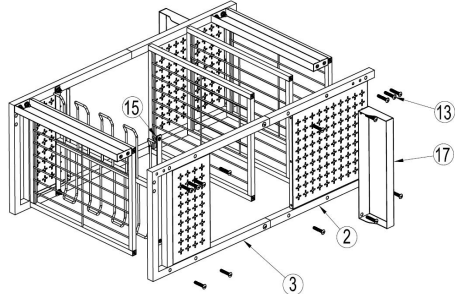

### Stap 7

Bevestig onderdeel " ⑦ " aan de constructie met schroeven " ⑭ " en moeren " ⑮ "

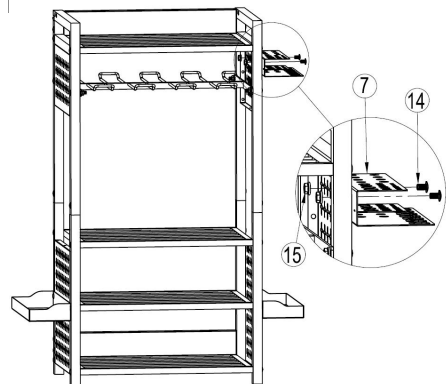

### Stap 8

Bevestig onderdeel " ⑱ " aan de constructie met schroeven " ⑭ "

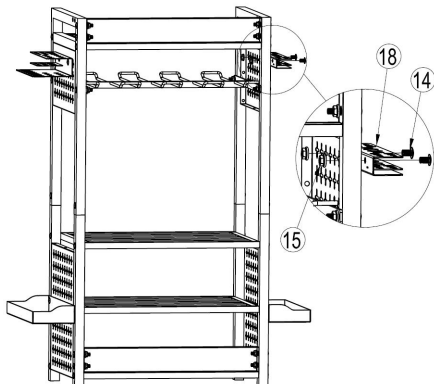

### Stap 9

Monteer de wielen " 10 " en " 11 " op de constructie met behulp van de sleutel " 12 "

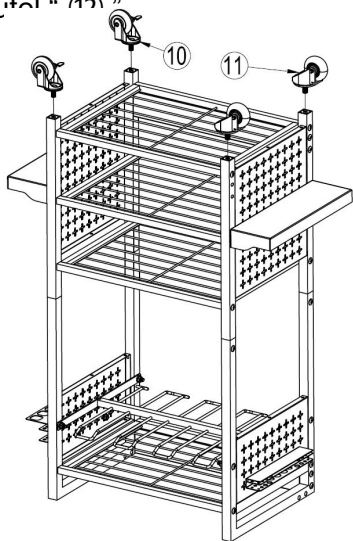

### Stap 10

Bevestig onderdeel " 16 " aan de constructie met schroeven " 13 " en " 15 "

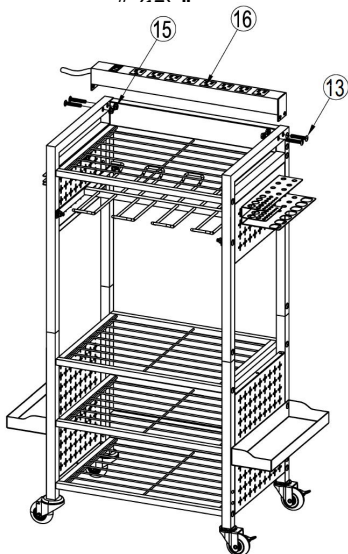

### Stap 11

Installeer onderdeel " 8 " op de assemblage zoals afgebeeld .

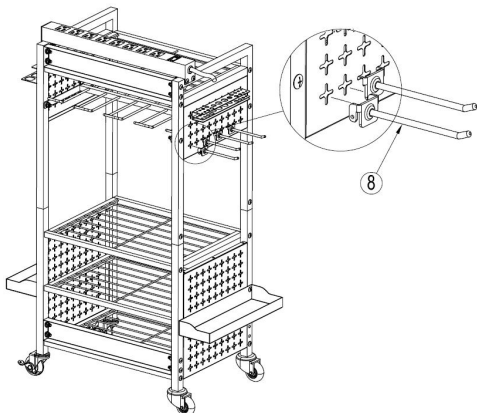

### Stap 12

Installeer onderdeel " 9 " op de assemblage zoals afgebeeld .

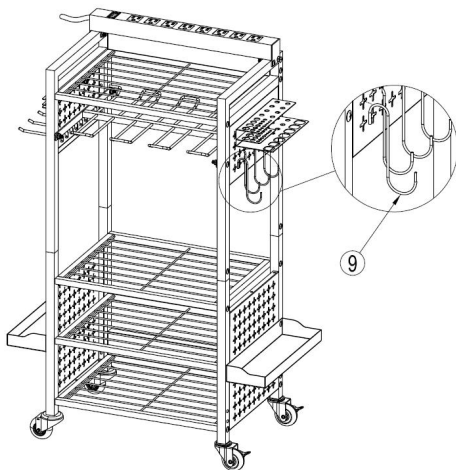

## Installatie voltooid

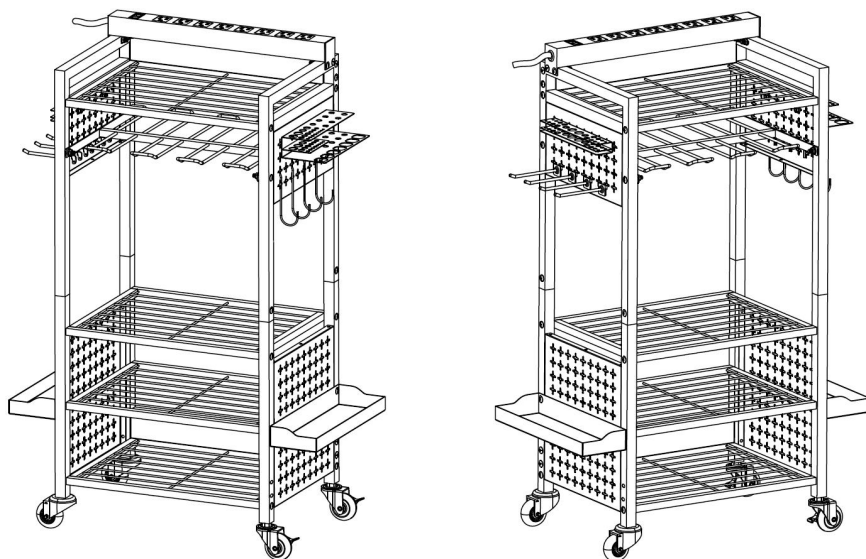

## PARAMETER

MODEL	ETT02
Kar body maat	42 0*3 0 0*8 65 mm
Totale belastinglimiet	1 5 0 pond
Type stopcontact	BY213-P08
Stroomaansluiting classificatie	15A 125V 60Hz Max.1875W

**Fabrikant:** Shanghaimuxinmuyeyouxiangongsi

**Adres:** Shuangchenglu 803nong11hao1602A-1609shi, baoshanqu, Sjanghai 200000 CN.

**Geïmporteerd naar AUS:** SIHAO PTY LTD. 1 ROKEVA

STREETEASTWOOD

NSW 2122 Australië

**Geïmporteerd naar de VS:** Sanven Technology Ltd. Suite 250, 9166

Anaheim

Plaats, Rancho Cucamonga, CA 91730

<b>UK</b>	<b>REP</b>
-----------	------------

YH CONSULTING LIMITED. C/O YH Consulting Limited Office 147, Centurion House, London Road, Staines-upon-Thames, Surrey, TW18 4AX

<b>EC</b>	<b>REP</b>
-----------	------------

E-CrossStu GmbH  
Mainzer Landstr.69,  
60329 Frankfurt am Main.



**Technische ondersteuning en e-garantiecertificaat**

**[www.vevor.com/support](http://www.vevor.com/support)**

# VEVOR

**Affordable. Reliable. Home Improvement.**

## **VERKTYGSVAGN**

**MODELL: ETT02**

Teknisk support och e-garanticertifikat  
[www.vevor.com/support](http://www.vevor.com/support)

# VEVOR

Affordable. Reliable. Home Improvement.





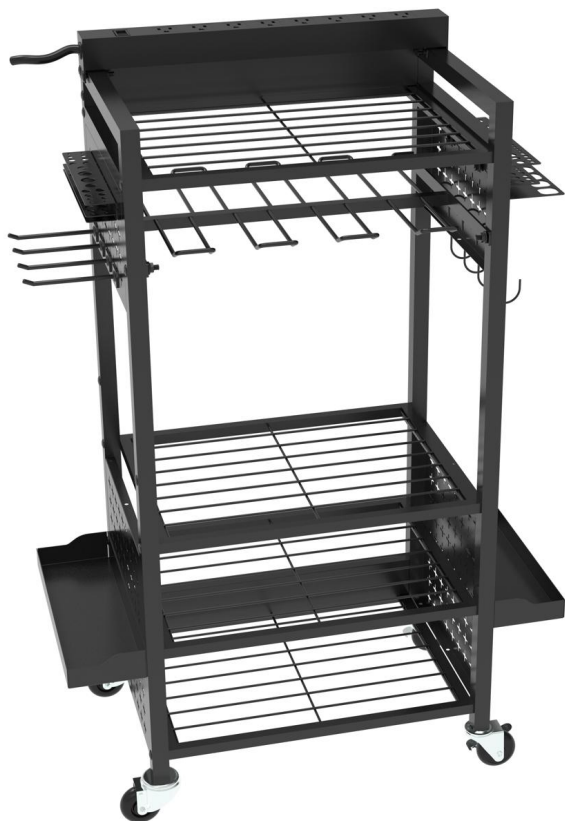





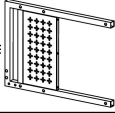

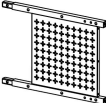

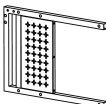

## TOOL CART

MODELL: ETT02

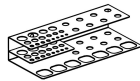

Detta är den ursprungliga instruktionen, läs alla instruktioner noggrant innan du använder den. VEVOR reserverar sig för en tydlig tolkning av vår användarmanual. Utseendet på produkten är beroende av den produkt du fått. Ursäkta oss att vi inte kommer att informera dig igen om det finns någon teknik eller mjukvaruuppdateringar på vår produkt.

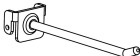
# LISTA ÖVER MONTERINGSDELAR

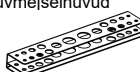
Antal	Beskrivning	Qt y	Antal	Beskrivning	Qt y
①	Vänster övre platta 	1	⑩	Hjul med lås 	2
②	Nedre montering 	2	⑪	Hjul utan lås 	2
③	Höger övre platta 	1	⑫	rycka 	1
④	Retikulerad platta 	4	⑬	M6x35 skruva 	32
⑤	H anging panel 	1	⑭	M6x10 skruva 	8
⑥	D am-board 	2	⑮	mutter 	20
⑦	Skruvhållare 	1	⑯	eluttag 	1
⑧	Hålkrok 	4	⑰	Sidoram 	2
⑨	P othook 	4	⑱	Hållare för skruvmejselhuvud 	1

## Säkerhetstips:

22. Lägg en mjuk trasa eller papper på golvet innan montering för att förhindra golvet från repar delarna.

23. Innan installationen, ta bort skyddsgummilocken på vänster och höger övre komponenter, som visas på den högra bilden.

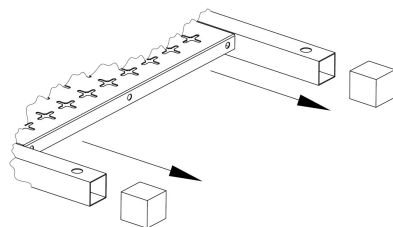

24. Den maximala belastningen för varje lager efter montering är 45 LBS.

4. Föremålen på varje lager ska vara jämnt fördelade.

**Obs: Dra inte åt skruvarna under installationen förrän alla delar är installerade.**

### Step 1

Anslut del " ① " och del " ② " med skruven " ⑭ " .

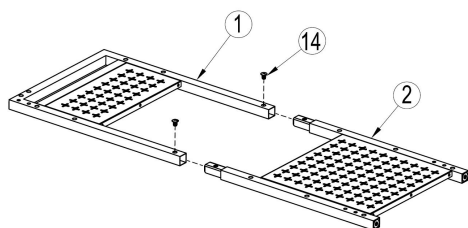

### Step 2

Anslut del " ③ " och del " ② " med skruven " ⑭ " .

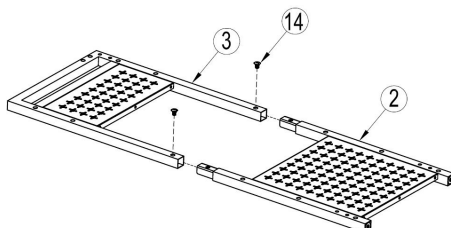

### Step 3

Fäst delarna " ④ " och " ⑰ " på monterade " ① " och " ② " med skruv " ⑬ " .

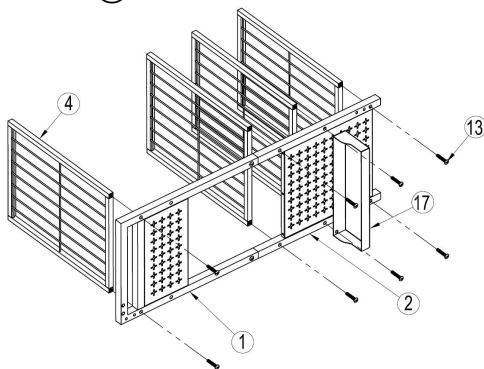

### Step 4

Fäst delen " ⑤ " på enheten med skruvarna " ⑬ " och muttrarna " ⑮ " .

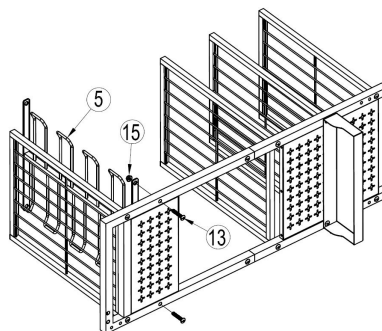

### Step 5

Fäst delen " ⑥ " på enheten med skruvarna " ⑬ " och muttrarna " ⑮ " .

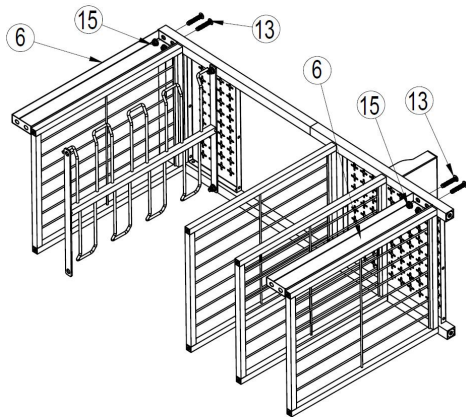

### Step 6

Upprepa steg 3-5 för att ansluta installationssatsen i steg 2 till installationskomponenten .

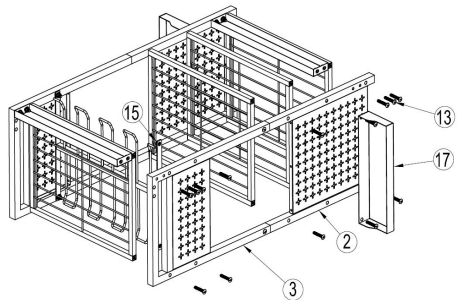

### Step 7

Fäst delen " ⑦ " på enheten med skruvarna " ⑭ " och muttrarna " ⑮ " .

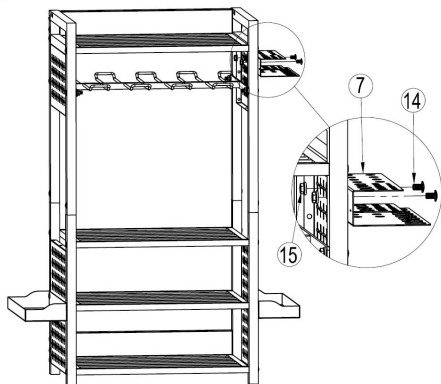

### Step 8

Fäst delen " ⑱ " på enheten med skruvarna " ⑭ " och muttrarna " ⑮ " .

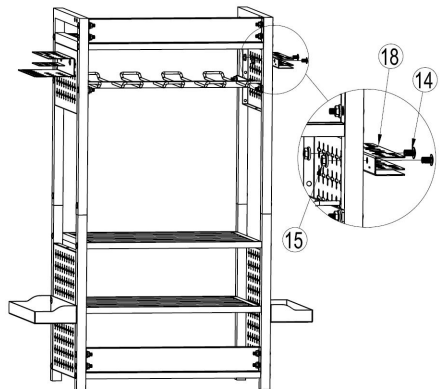

### Step 9

Montera hjulen " ⑩ " och " ⑪ " på enheten med skiftnyckel " ⑫ " .

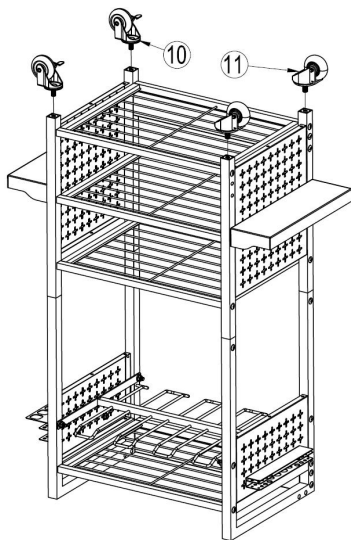

### Step 10

Fäst delen " ⑬ " till monteringen med skruvarna " ⑭ " och muttern " ⑮ " .

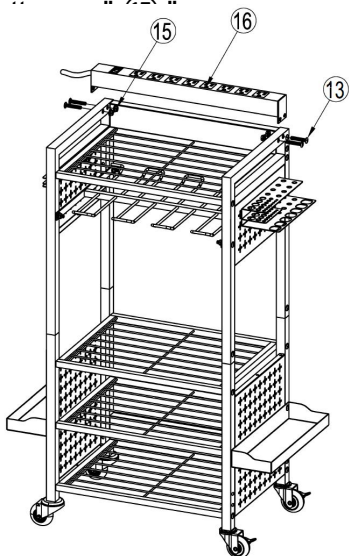

### Step 11

Installera delen " ⑧ " på enheten enligt bilden .

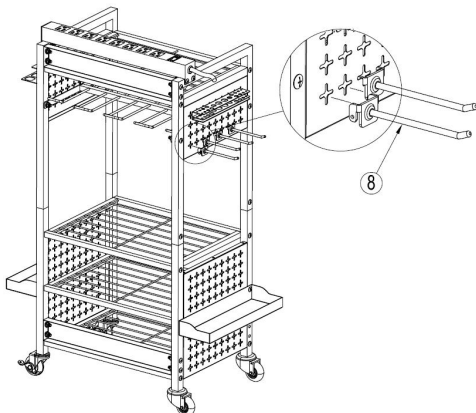

### Step 12

Montera delen " ⑨ " på enheten enligt bilden .

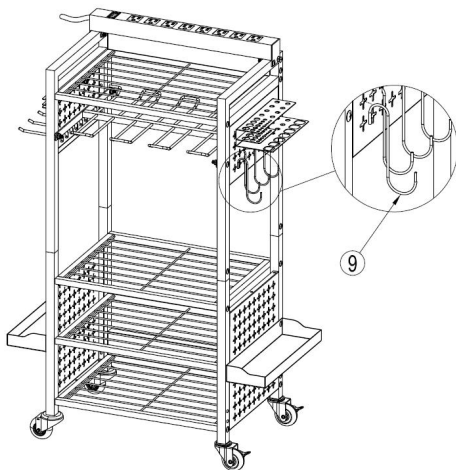

**I nstallationen är klar**

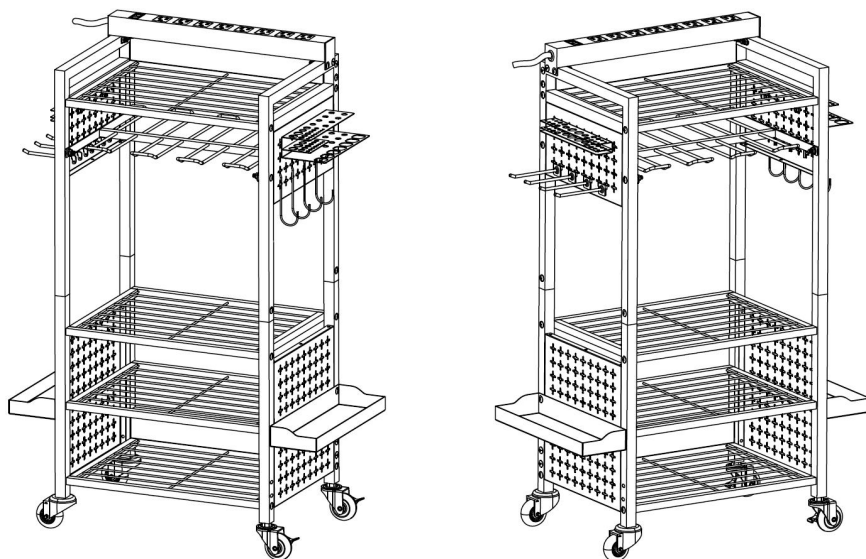

## **PARAMETER**

<b>MODELL</b>	<b>ETT0 2</b>
Varukorgens kroppsstorlek	42 0*3 0 0*8 65 mm
Total lastgräns	1 5 0 lbs
Typ av eluttag	BY213-P08
Betyg för strömuttag	15A 125V 60Hz Max.1875W

**Tillverkare:** Shanghaimuxinmuyeyouxiangongsi

**Adress:** Shuangchenglu 803nong11hao1602A-1609shi, baoshanqu, shanghai 200 000 CN.

**Importerad till AUS:** SIHAO PTY LTD. 1 ROKEVA STREETEASTWOOD NSW 2122 Australien

**Importerad till USA:** Sanven Technology Ltd. Suite 250, 9166 Anaheim Place, Rancho Cucamonga, CA 91730



YH CONSULTING LIMITED. C/O YH Consulting Limited Office 147, Centurion House, London Road, Staines-upon-Thames, Surrey, TW18 4AX



E-CrossStu GmbH  
Mainzer Landstr.69,  
60329 Frankfurt am Main.



**Teknisk support och e-garanticertifikat**  
[www.vevor.com/support](http://www.vevor.com/support)