

# ASSEMBLY INSTRUCTIONS INSTRUCTIONS DE MONTAGE

N717P404326

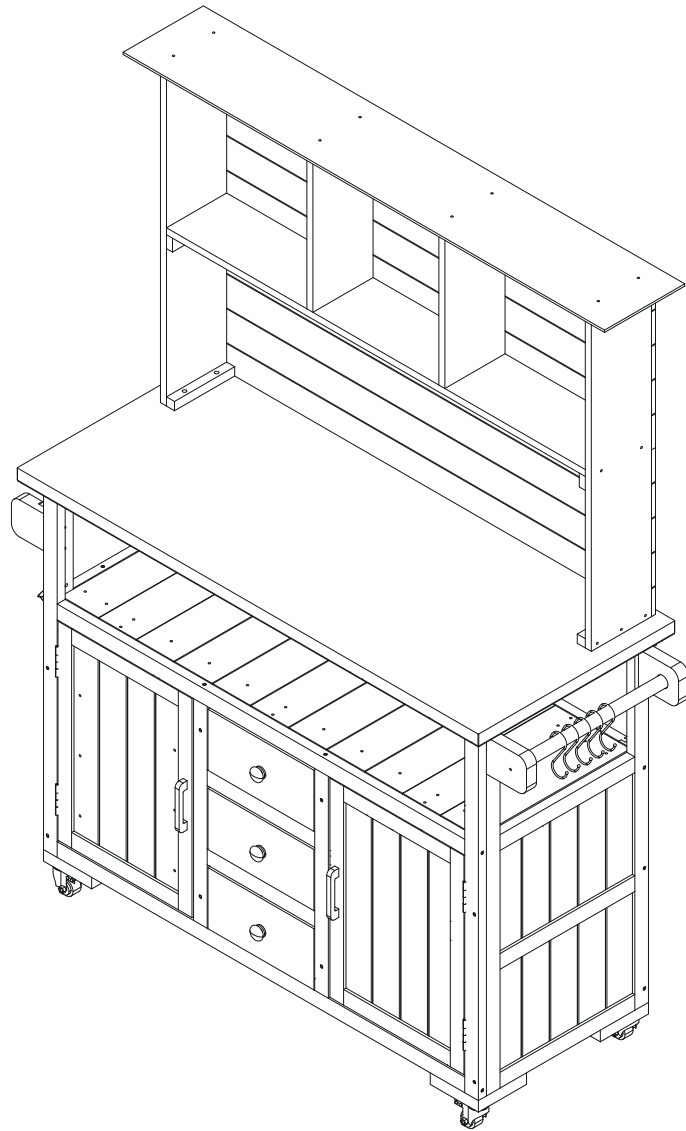

## IMPORTANT NOTE :

- ① PLACE ALL PARTS ON A CLEAN AND SMOOTH SURFACE SUCH AS A RUG OR CARPET TO AVOID THE PARTS FROM BEING SCRATCHED.
- ② BEFORE YOU BEGIN, KINDLY FOLLOW THE ASSEMBLY INSTRUCTIONS STEP BY STEP.
- ③ DO NOT TIGHTEN ALL SCREWS AND BOLTS UNTIL THIS ITEM IS FULLY SET-UP.

## NOTE IMPORTANTE:

- ① PLACEZ TOUTES LES PIÈCES SUR UNE SURFACE PROPRE ET LISSE TELLE QU'UN TAPIS OU UN TAPIS POUR ÉVITER LES PIÈCES D'ÊTRE RAYÉES.
- ② AVANT DE COMMENCER, VEUILLEZ SUIVRE LES INSTRUCTIONS D'ASSEMBLAGE ÉTAPE PAR ÉTAPE.
- ③ NE SERREZ PAS TOUTES LES VIS ET LES BOULONS TANT QUE CET ARTICLE N'EST PAS ENTIÈREMENT INSTALLÉ.

# Detail View Vue détaillée

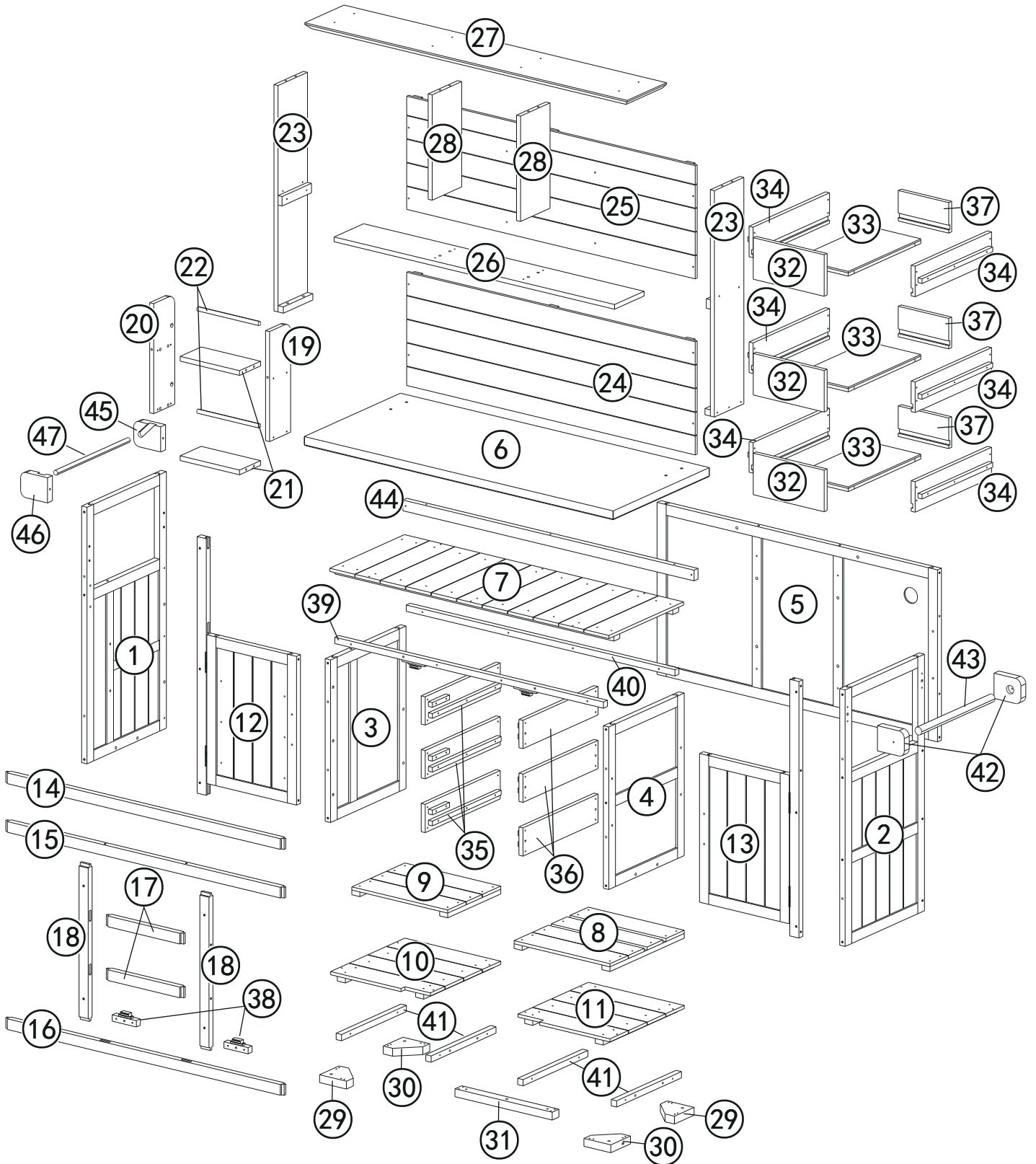



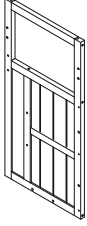
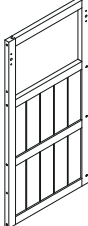
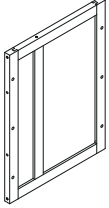
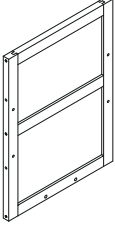
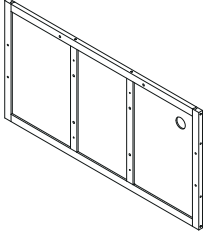
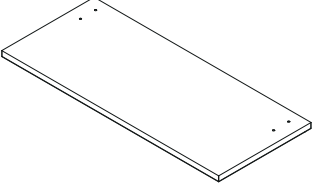
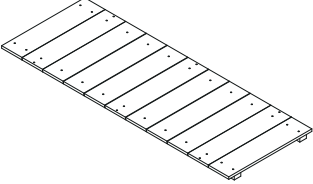
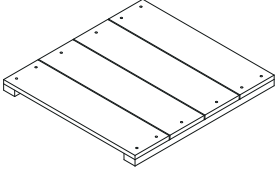
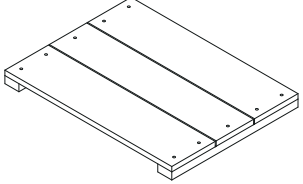
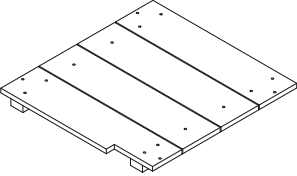
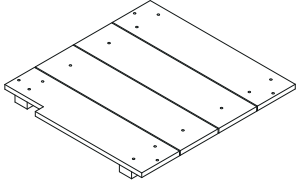
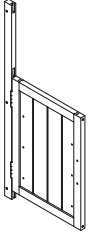
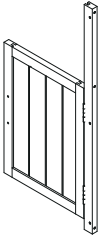
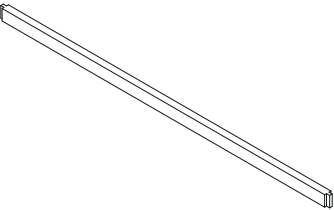
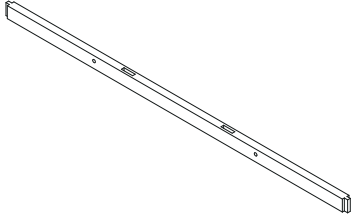
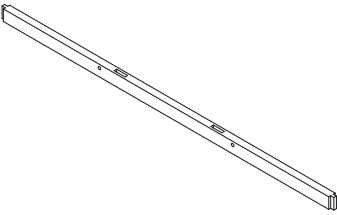
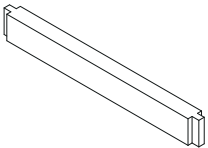
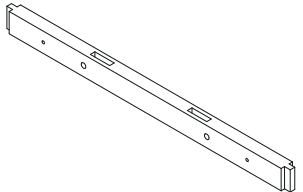

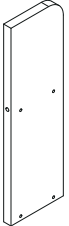
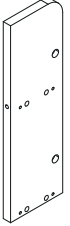
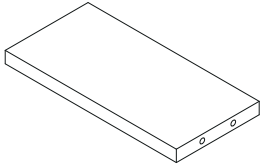
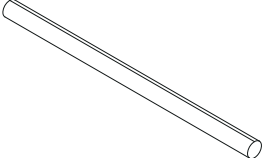
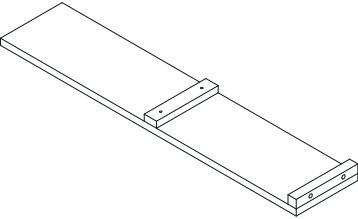
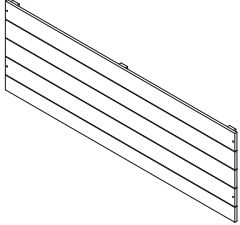
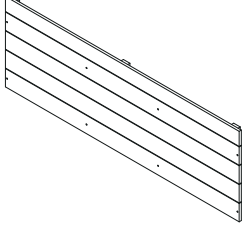
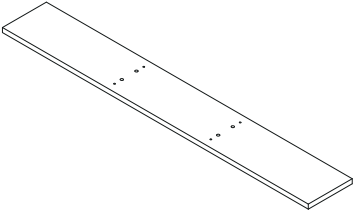
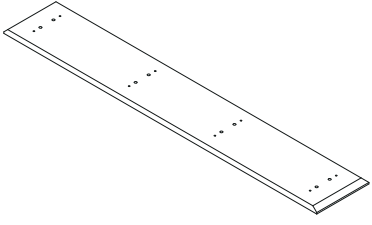
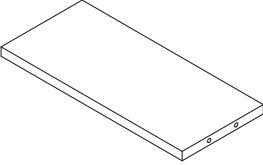
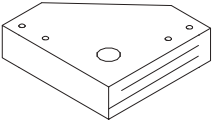
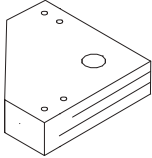
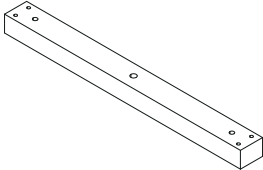
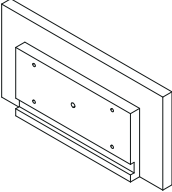
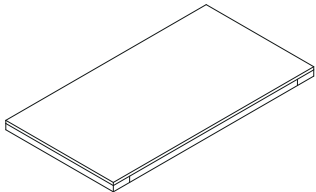
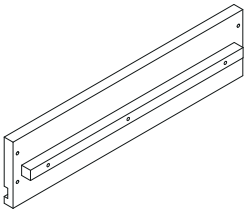
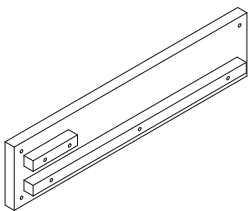
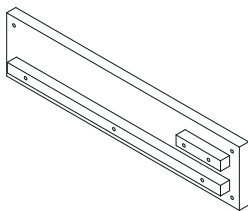

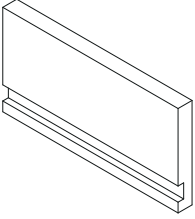
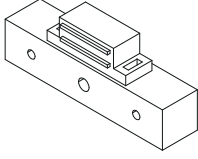
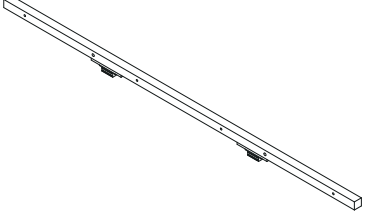
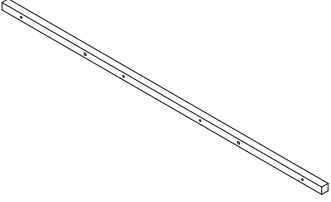
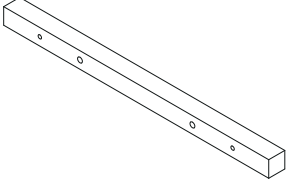
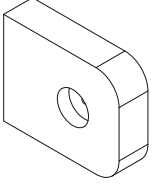
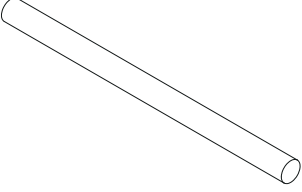
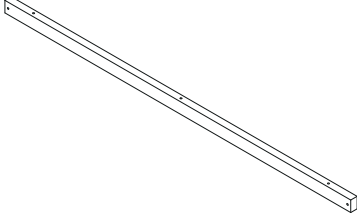
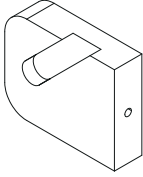
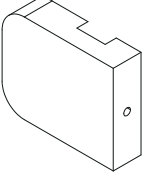
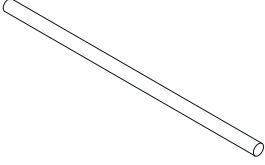















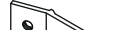

Part list(N717P404326)  
Liste du matériel(N717P404326)

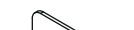
<p>1</p> 	<p>2</p> 	<p>3</p> 
<p>Left side panel-1pc Panneau latéral gauche-1pc</p>	<p>Right side panel-1pc Panneau latéral-1pc</p>	<p>Left middle panel-1pc Panneau central gauche-1pc</p>
<p>4</p> 	<p>5</p> 	<p>6</p> 
<p>Right middle panel-1pc Panneau central droit-1pc</p>	<p>Back panel-1pc Panneau arrière-1pc</p>	<p>Table top-1pc Dessus de table-1pc</p>
<p>7</p> 	<p>8</p> 	<p>9</p> 
<p>Shelf 1-1pc Étagère 1-1pc</p>	<p>Shelf 2-1pc Étagère 2-1pc</p>	<p>Shelf 3-1pc Étagère 3-1pc</p>
<p>10</p> 	<p>11</p> 	<p>12</p> 
<p>Bottom panel 1-1pc Panneau inférieur 1-1pc</p>	<p>Bottom panel 2-1pc Panneau inférieur 2-1pc</p>	<p>Left front panel-1pc Panneau avant gauche-1pc</p>
<p>13</p> 	<p>14</p> 	<p>15</p> 
<p>Right front panel-1pc Panneau avant droit-1pc</p>	<p>Upper crossbar of front panel-1pc Slat supérieur du panneau avant-1pc</p>	<p>Middle slat of front panel-1pc Latte médiane du panneau avant-1pc</p>
<p>16</p> 	<p>17</p> 	<p>18</p> 
<p>Lower slat of front panel-1pc Latte inférieure du panneau avant-1pc</p>	<p>Short slat of front panel-2pcs Latte courte du panneau avant-2pcs</p>	<p>Middle vertical partition of front panel-2pcs Cloison verticale centrale du panneau avant-2pcs</p>

<p>19</p> 	<p>20</p> 	<p>21</p> 
<p>Left vertical partition of the storage rack-1pc Cloison verticale gauche du rayonnage de stockage-1pc</p>	<p>Right vertical partition of the storage rack-1pc Cloison verticale droite du rayonnage de stockage-1pc</p>	<p>The slat of storage rack-2pcs La latte du rayonnage de stockage-2pcs</p>
<p>22</p> 	<p>23</p> 	<p>24</p> 
<p>Round stick 1-2pcs Bâton rond 1-2pcs</p>	<p>Upper side panel-2pcs Panneau latéral supérieur-2pcs</p>	<p>Middle back panel-1pc Panneau arrière milieu-1pc</p>
<p>25</p> 	<p>26</p> 	<p>27</p> 
<p>Upper back panel-1pc Panneau arrière supérieur-1pc</p>	<p>Flat panel 1-1pc Panneau plat 1-1pc</p>	<p>Flat panel 2-1pc Panneau plat 2-1pc</p>
<p>28</p> 	<p>29</p> 	<p>30</p> 
<p>Flat panel 3-2pcs Panneau plat 3-2pcs</p>	<p>Base 1-2pcs</p>	<p>Base 2-2pcs</p>
<p>31</p> 	<p>32</p> 	<p>33</p> 
<p>Base 3-1pc</p>	<p>Front panel of drawer -3pcs Panneau avant du tiroir-3pcs</p>	<p>Bottom panel of drawer-3pcs Panneau inférieur du tiroir-3pcs</p>
<p>34</p> 	<p>35</p> 	<p>36</p> 
<p>Side panel of drawer -6pcs Panneau latéral du tiroir-6pcs</p>	<p>Left side support panel of the drawer-3pcs Panneau de support gauche du tiroir-3pcs</p>	<p>Right side support panel of the drawer-3pcs Panneau de support droit du tiroir-3pcs</p>

<p>37</p> 	<p>38</p> 	<p>39</p> 
<p>Back panel of drawer-3pcs Panneau arrière du tiroir-3pcs</p>	<p>Magnetic wooden strips 1 -2pcs Bandes de bois magnétique 1-2pcs</p>	<p>Magnetic wooden strips 2-1pc Bandes de bois magnétique 2-1pc</p>
<p>40</p> 	<p>41</p> 	<p>42</p> 
<p>Back panel support strip-1pc Bande de support pour panneau arrière-1pc</p>	<p>Bottom panel support strip-4pcs Bande de support du panneau inférieur-4pcs</p>	<p>Positioning block 1-2pcs Bloc de positionnement 1-2pcs</p>
<p>43</p> 	<p>44</p> 	<p>45</p> 
<p>Round stick 2-1pc Bâton rond 2-1pc</p>	<p>Back panel support strip-1pc Bande de support pour panneau arrière-1pc</p>	<p>Positioning block 2-1pc Bloc de positionnement 2-1pc</p>
<p>46</p> 	<p>47</p> 	
<p>Positioning block 3-1pc Bloc de positionnement 3-1pc</p>	<p>Round stick 3-1pc Bâton rond 3-1pc</p>	

Hardware List  
Liste du matériel

<p><b>A</b></p>  <p>φ3.5x60</p>	<p><b>B</b></p>  <p>φ3.5x40</p>	<p><b>C</b></p>  <p>φ3.0x35</p>	<p><b>D</b></p>  <p>φ3.0x30</p>
<p>Ph zinc screws-17+1pcs Vis de zinc ph-17+1pcs</p>	<p>Ph zinc screws-46+1pcs Vis de zinc ph-46+1pcs</p>	<p>Ph zinc screws-20+1pcs Vis de zinc ph-20+1pcs</p>	<p>Ph zinc screws-80+1pcs Vis de zinc ph-80+1pcs</p>
<p><b>E</b></p>  <p>φ3.0x25</p>	<p><b>F</b></p> 	<p><b>G</b></p>  <p>M5*30</p>	<p><b>H</b></p>  <p>M4*25</p>
<p>Ph zinc screws-26+1pcs Vis de zinc ph-26+1pcs</p>	<p>Wood dowel-70+2pcs Cheville à bois-70+2pcs</p>	<p>Ph zinc bolt-2+1pcs Boulon de zinc ph-2+1pcs</p>	<p>Ph zinc bolt-7+1pcs Boulon de zinc ph-7+1pcs</p>
<p><b>I</b></p>  <p>φ3.5x16</p>	<p><b>J</b></p> 	<p><b>K</b></p> 	<p><b>L</b></p> 
<p>Ph zinc screws-10+1pcs Vis de zinc ph-10+1pcs</p>	<p>Door knob-3pcs Bouton de porte-3pcs</p>	<p>Connecting iron pieces-1pc Pièces de fer de connexion -1pc</p>	<p>Door handle-2pcs Poignée de porte -2pcs</p>
<p><b>M</b></p> 	<p><b>N</b></p> 	<p><b>O</b></p> 	<p><b>P</b></p> 
<p>Fixed wheel-3pcs Roue fixe-3pcs</p>	<p>Brake wheel-2pcs Roue de frein-2pcs</p>	<p>Bottle opener-1pc Ouvre-bouteille-1pc</p>	<p>5 cm drawer stopper-6pcs Butée de tiroir de 5 cm-6pcs</p>
<p><b>Q</b></p> 	<p><b>R</b></p> 	<p><b>S</b></p> 	<p><b>T</b></p>  <p>M6*35</p>
<p>S Hook-5pcs S Crochet-5pcs</p>	<p>Pull box-1pc Boîte à tirer-1pc</p>	<p>Angle steel-3pcs Cornière en acier-3pcs</p>	<p>Ph zinc bolt-4+1pcs Boulon de zinc ph-4+1pcs</p>
<p><b>U</b></p> 	<p><b>V</b></p> 	<p><b>W</b></p>  <p>φ3.0x16</p>	<p><b>X</b></p> 
<p>L shape metal-2pcs Métal en forme de L-2pcs</p>	<p>Ground nail-2pcs Clou de sol-2pcs</p>	<p>Ph zinc screws-11+1pcs Vis de zinc ph-11+1pcs</p>	<p>Laminated nail-8pcs Clou laminé-8pcs</p>
<p><b>Y</b></p> 	<p><b>L shape wrench</b></p> 		
<p>Open-end Wrench-1pc Clé à fourche-1pc</p>	<p>L shape wrench-1pc Clé en L-1pc</p>		

ASSEMBLY TOOLS REQUIRED( NOTINCLUDED)  
OUTILS D'ASSEMBLAGE REQUIS (NON INCLUS)

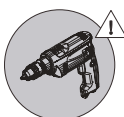

PLEASE BE CAREFUL DO NOT DAMAGE THE HOLE  
POSITION WHEN YOU USE POWERTOOLS!  
VEUILLEZ FAIRE ATTENTION À NE PAS ENDOMMAGER LA POSITION DU  
TROU LORS DE L'UTILISATION D'OUTILS ÉLECTRIQUES!

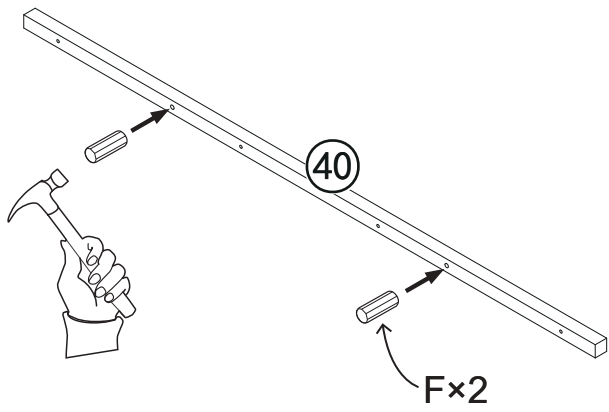

1

40 x 1  
F x 2

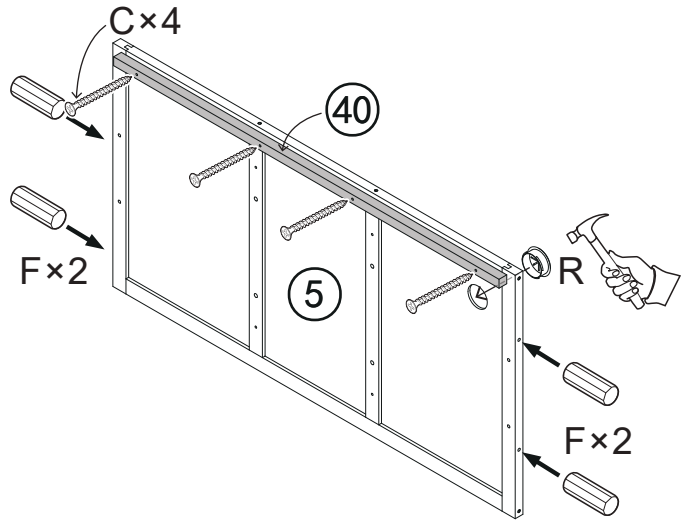

2

5 x 1  
F x 4 C x 4 R x 1

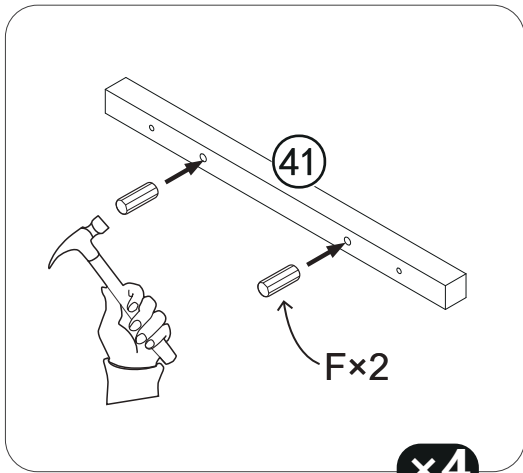

3

41 x 4  
F x 8

x 4

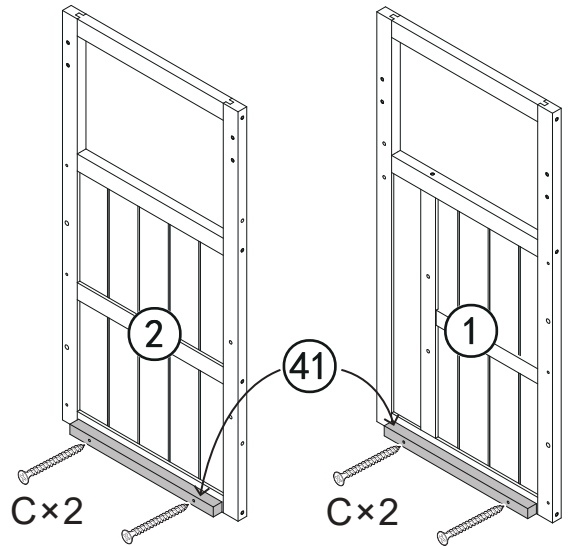

4

1 x 1 2 x 1  
C x 4

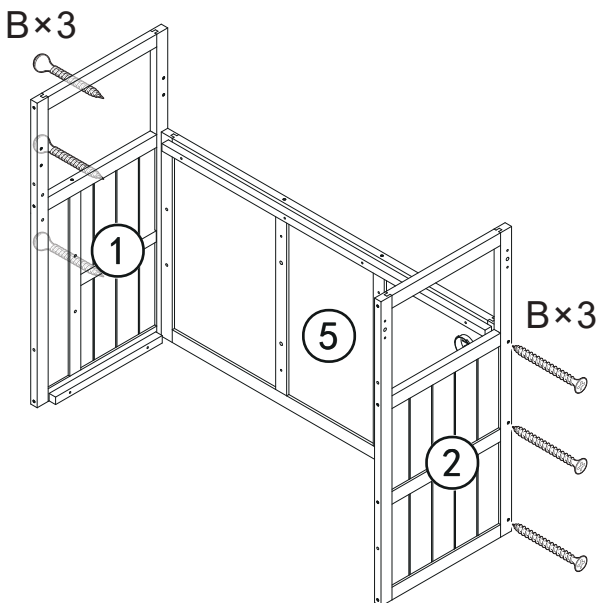

5

B x 6

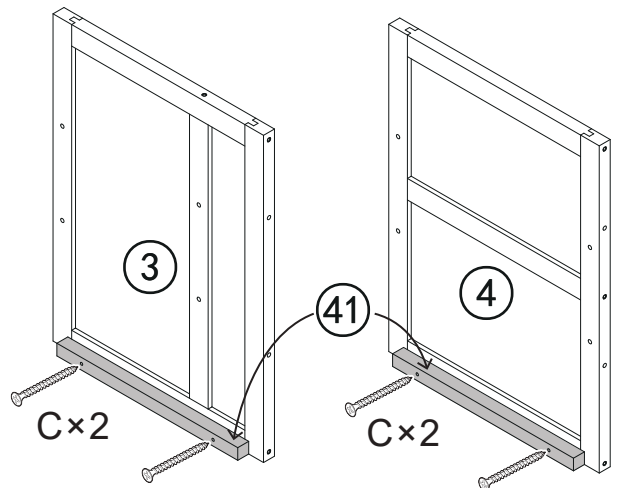

6

3 x 1 4 x 1  
C x 4

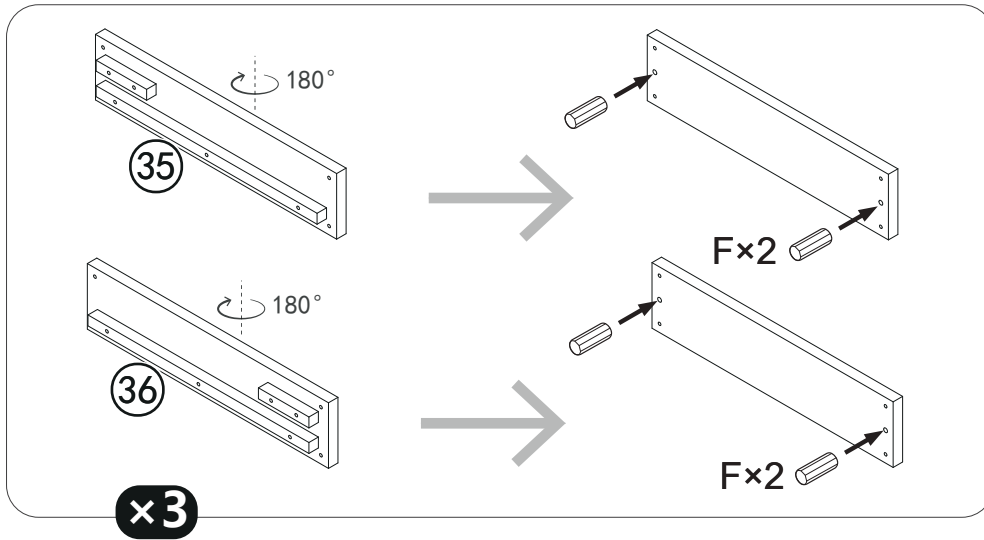

7

35 x 3 36 x 3  
F x 12

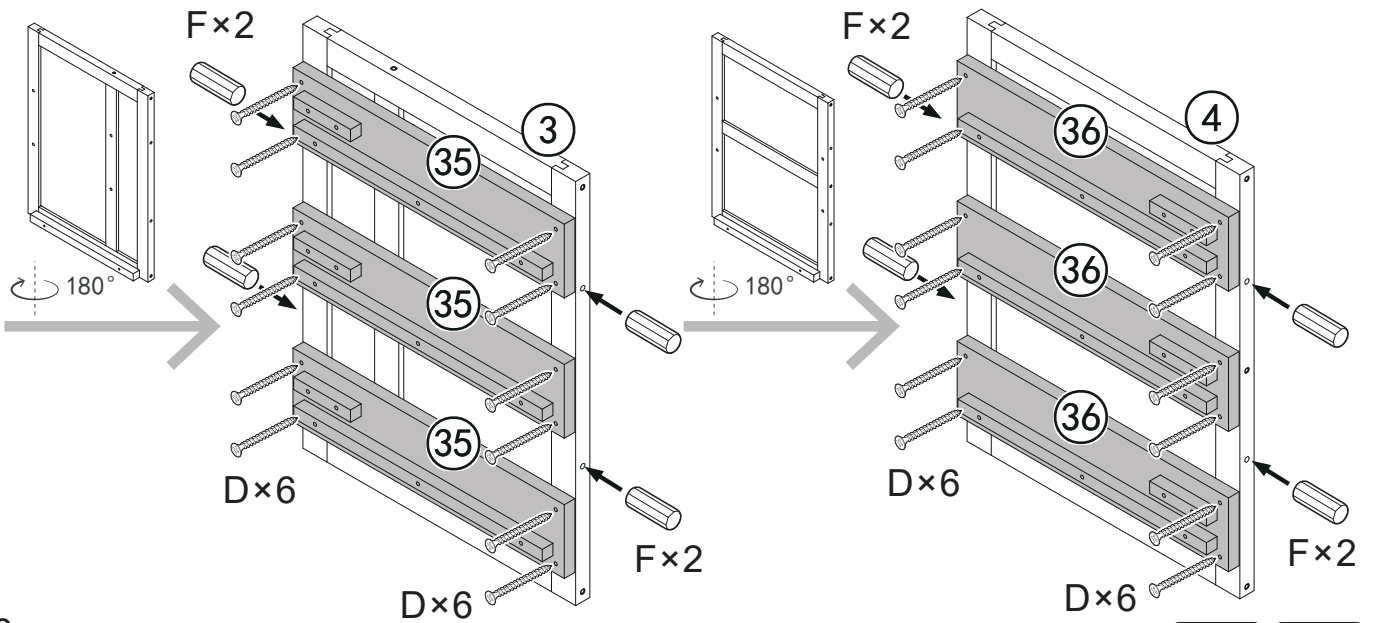

8

D x 24 F x 8

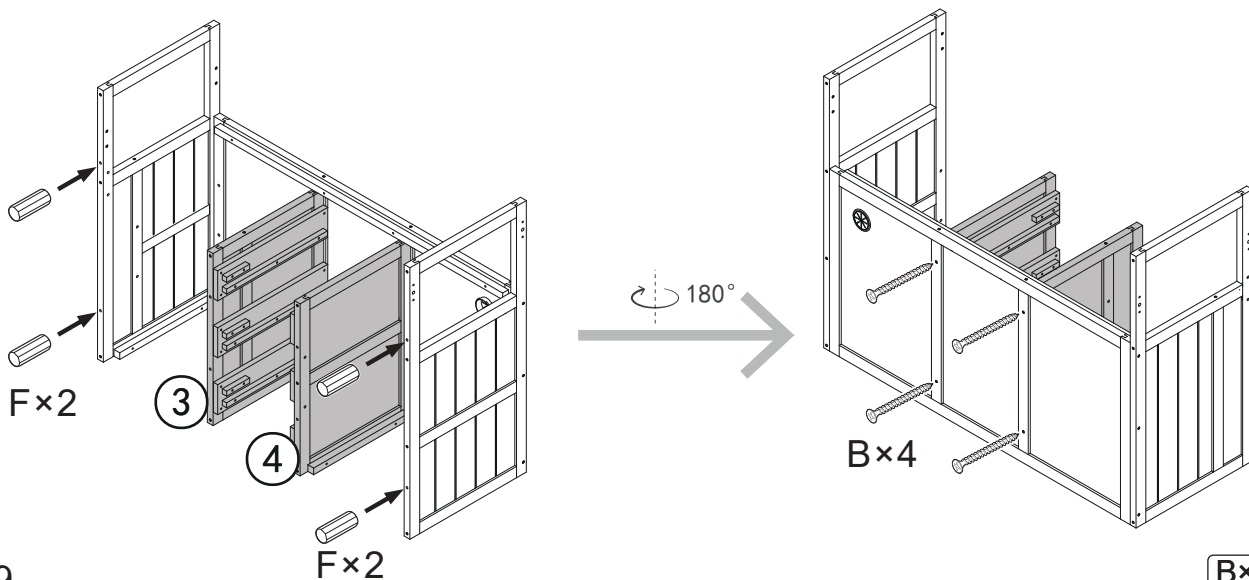

9

B x 4 F x 4

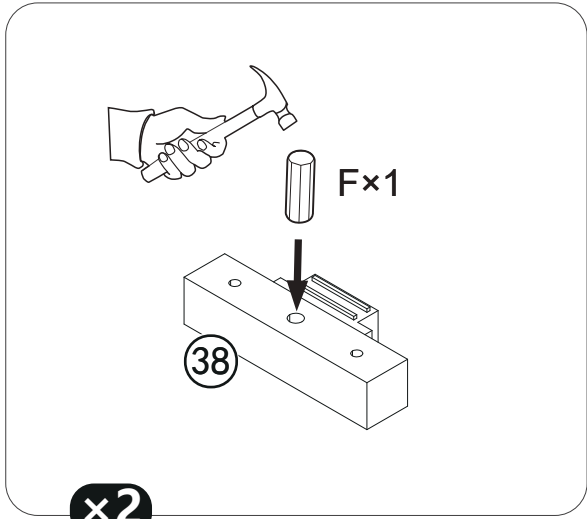

**x2**

10

**38 x 2**  
**F x 2**

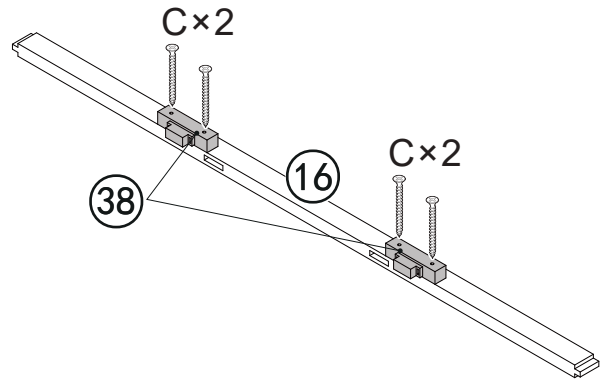

11

**16 x 1**  
**C x 4**

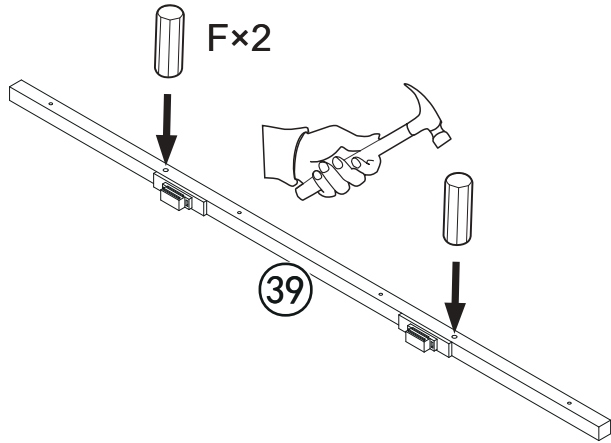

12

**39 x 1**  
**F x 2**

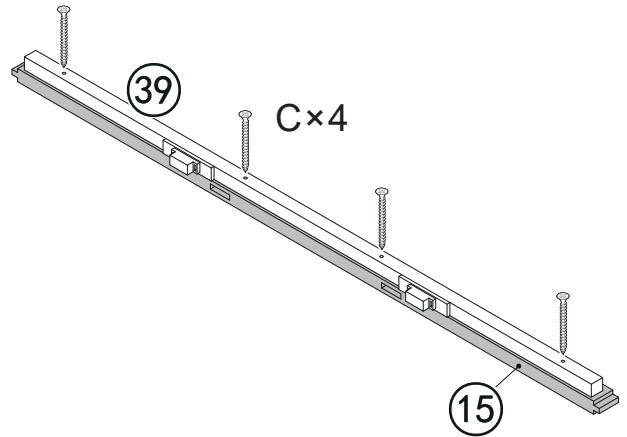

13

**15 x 1**  
**C x 4**

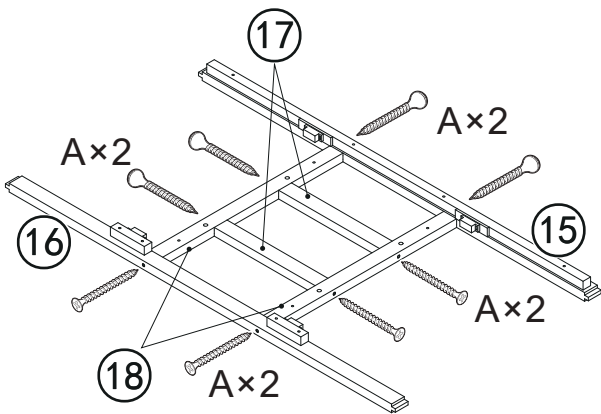

14

**17 x 2** **18 x 2**  
**A x 8**

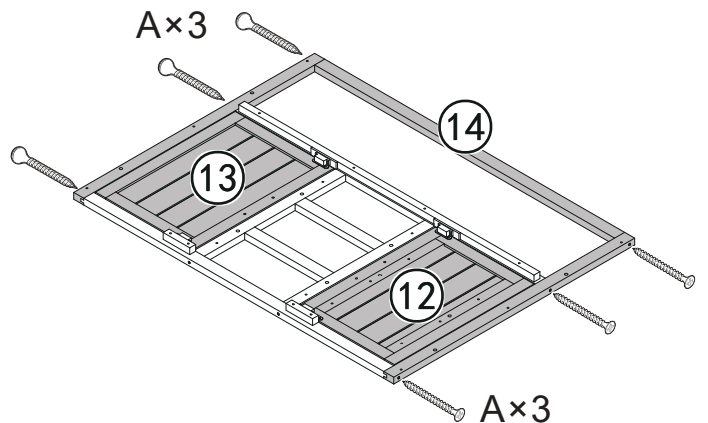

15

**12 x 1** **13 x 1** **14 x 1**  
**A x 6**

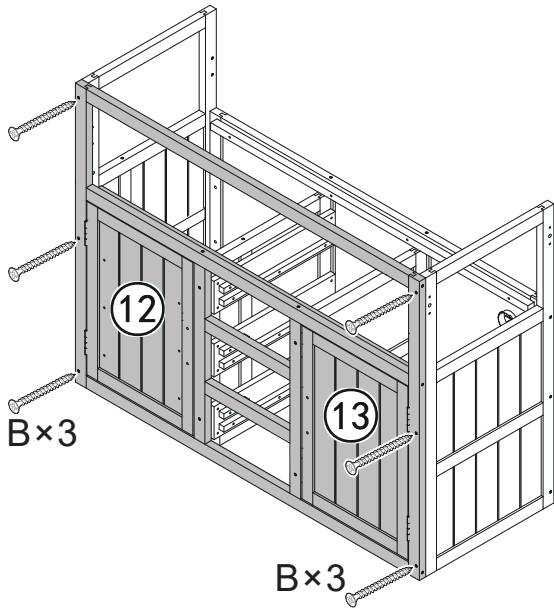

16

Bx6

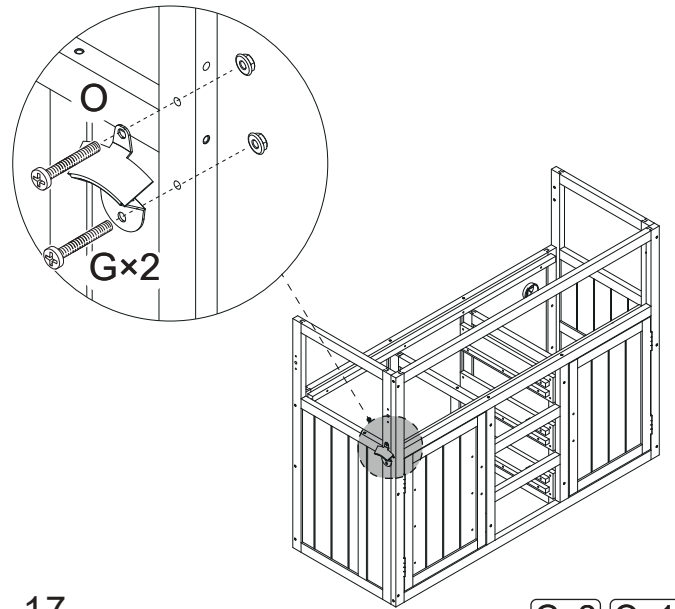

17

Gx2 Ox1

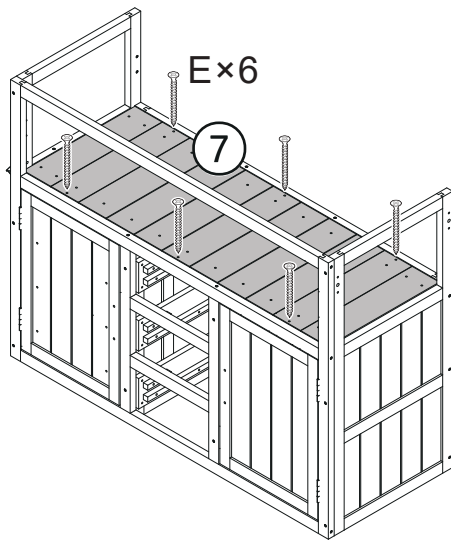

18

7x1  
Ex6

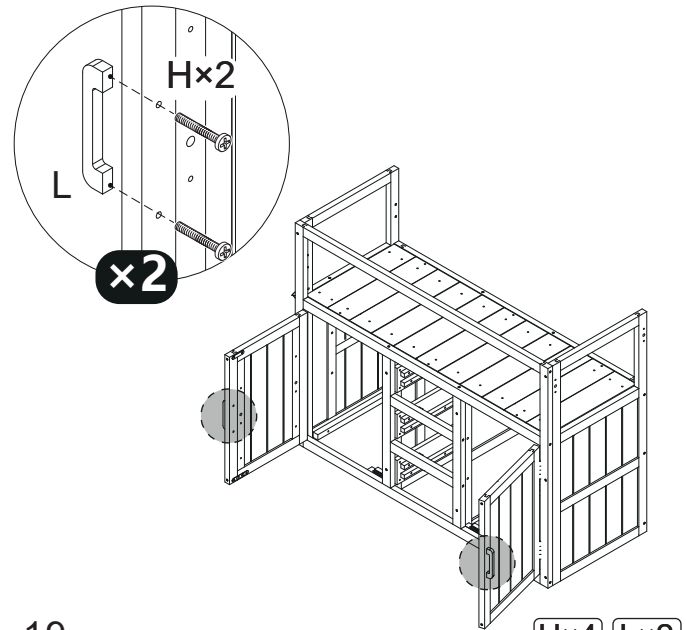

19

Hx4 Lx2

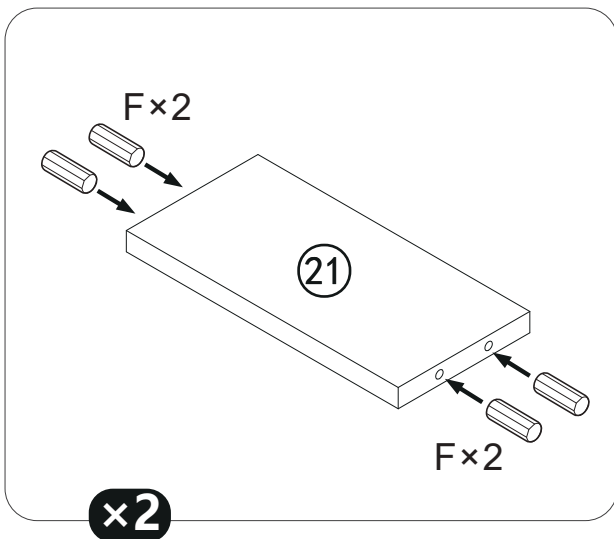

20

21x2  
Fx8

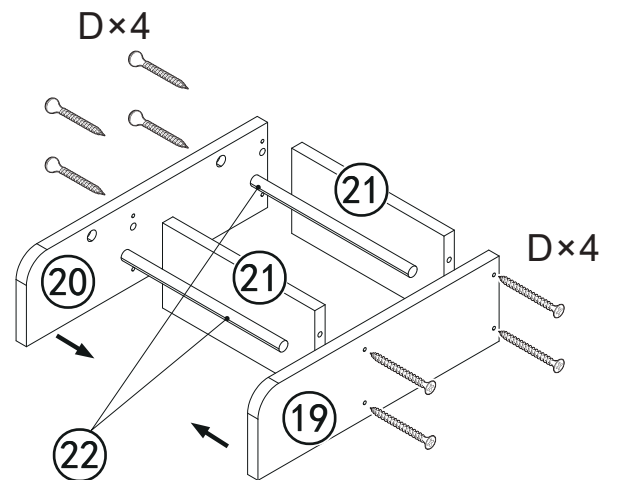

21

19x1 20x1 22x2  
Dx8

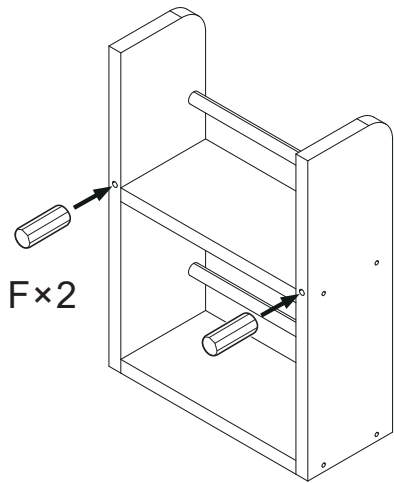

22

F x 2

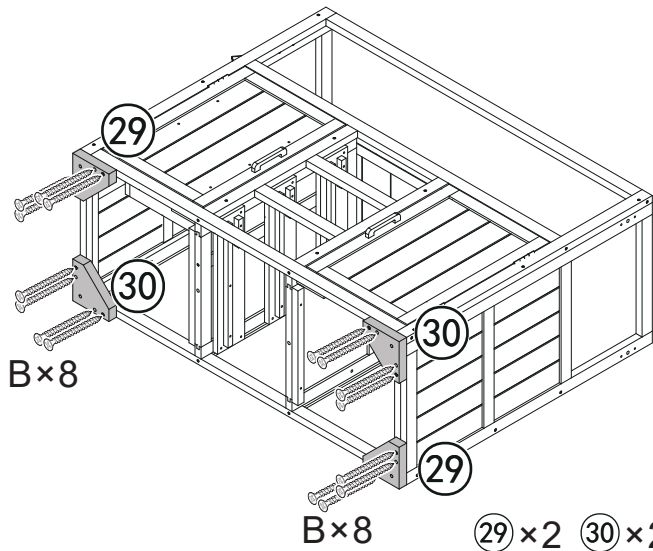
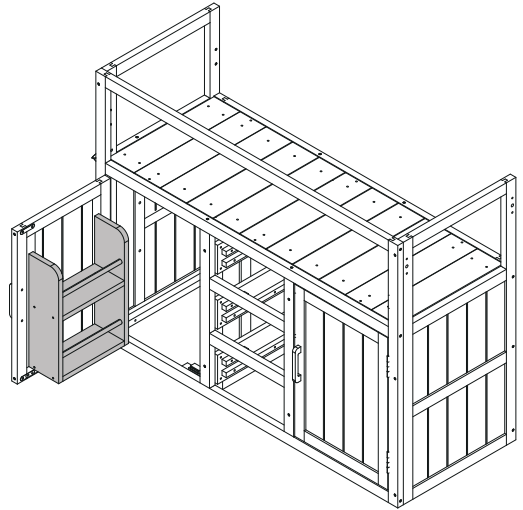

24

B x 8  
 (29) x 2 (30) x 2  
 B x 16

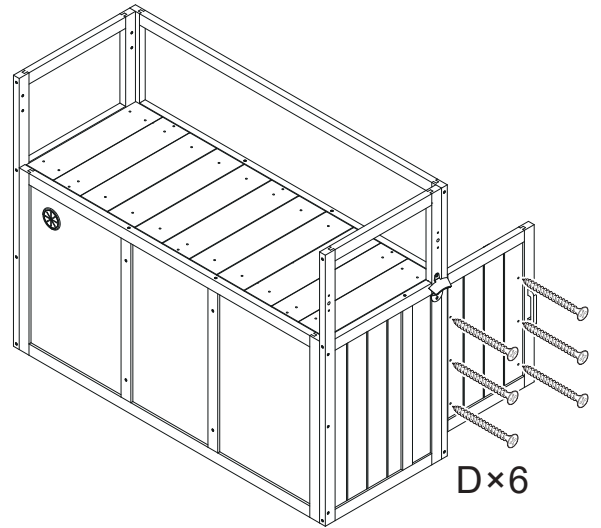

23

D x 6

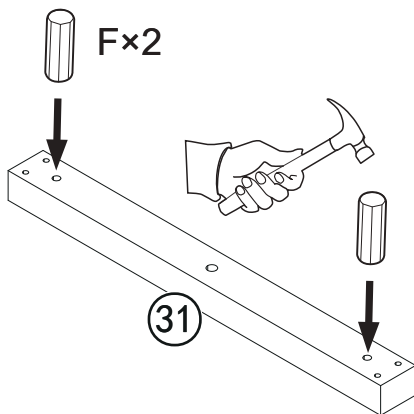

25

(31) x 1  
 F x 2

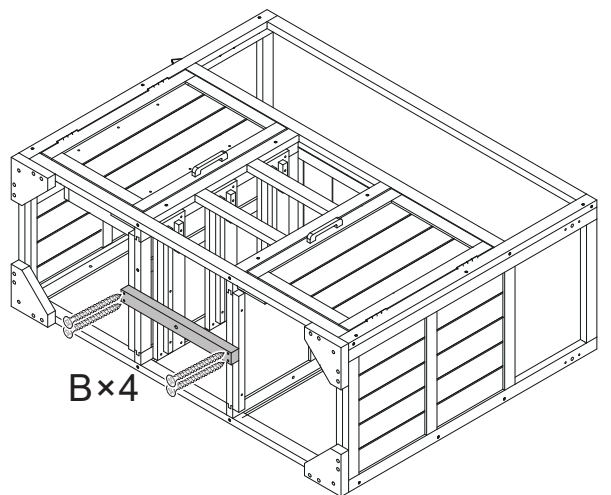

26

B x 4

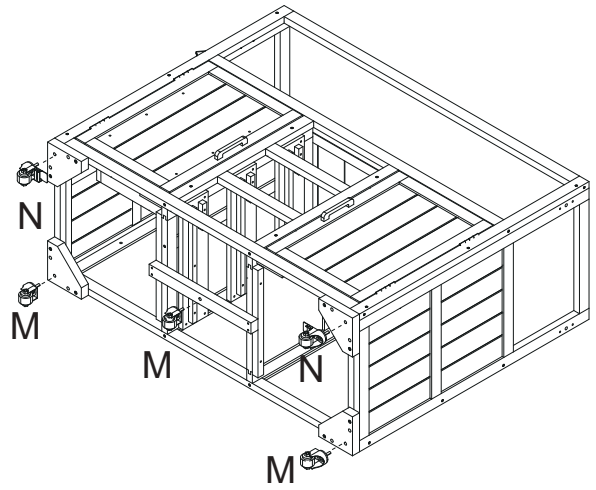
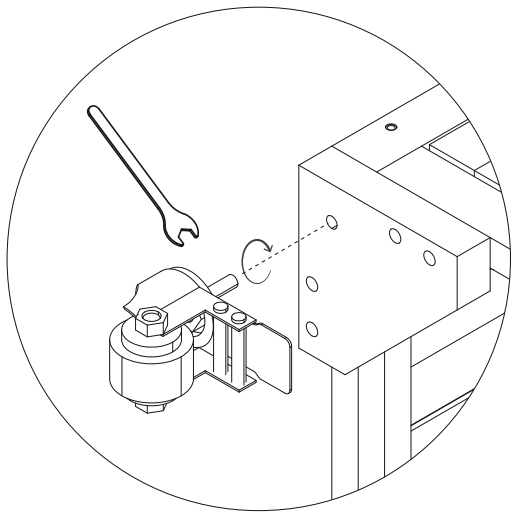

27

M×3 N×2 Y×1

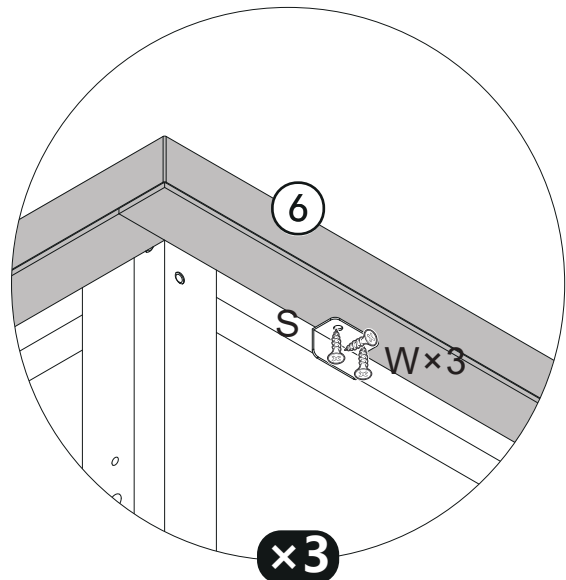
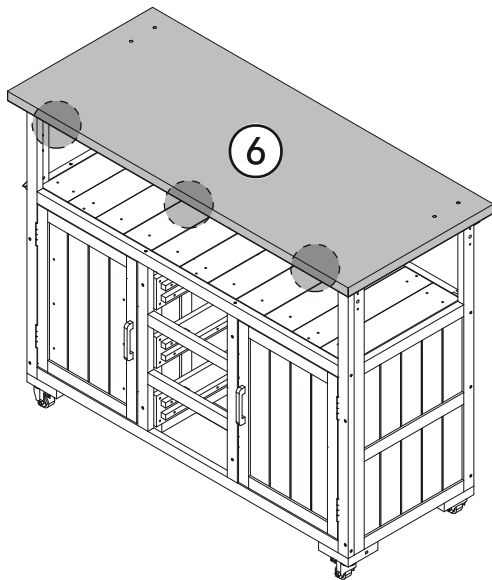

28

6×1  
W×9 S×3

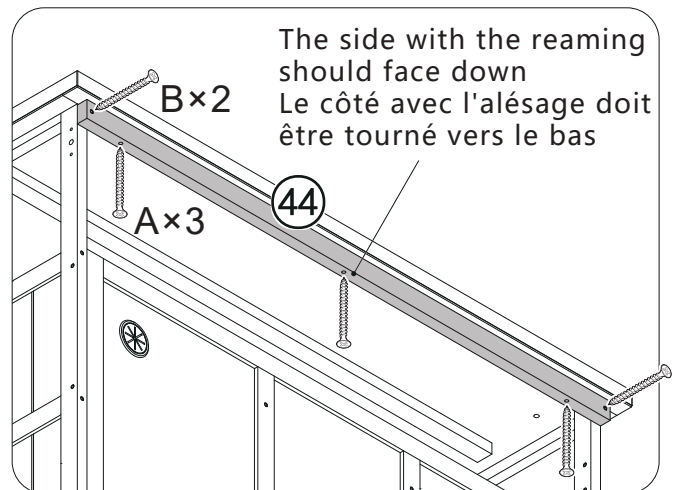
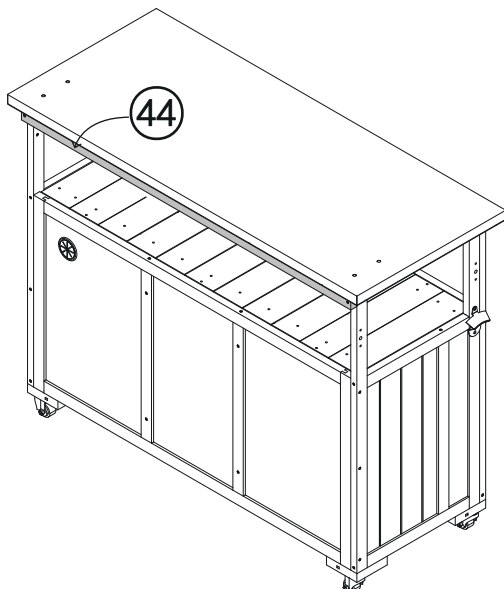

29

44×1  
A×3 B×2

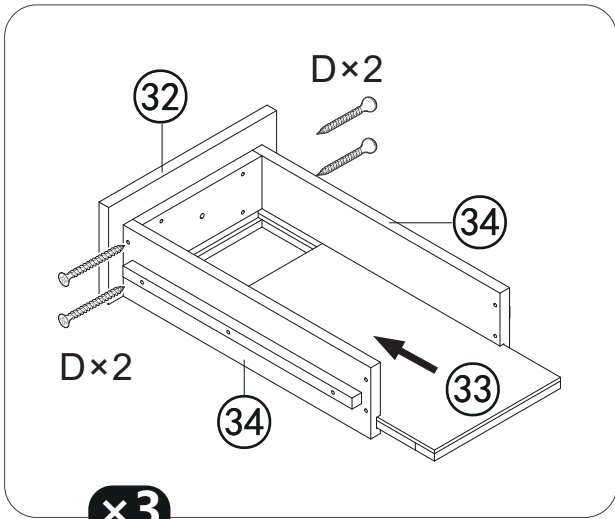

30

32 x 3 33 x 3 34 x 6  
D x 12

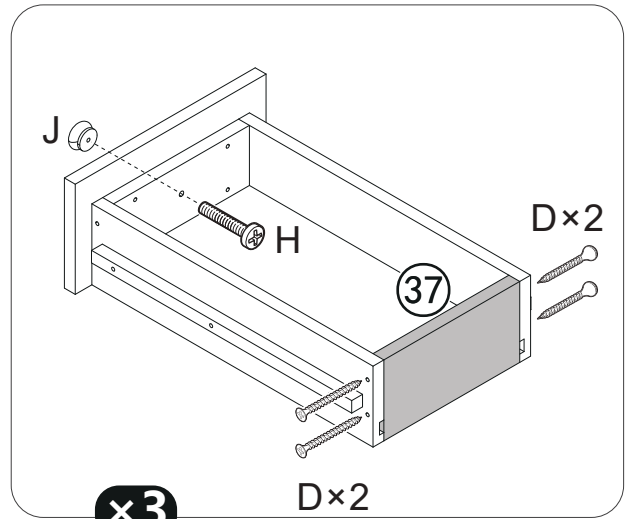

31

37 x 3  
D x 12 H x 3 J x 3

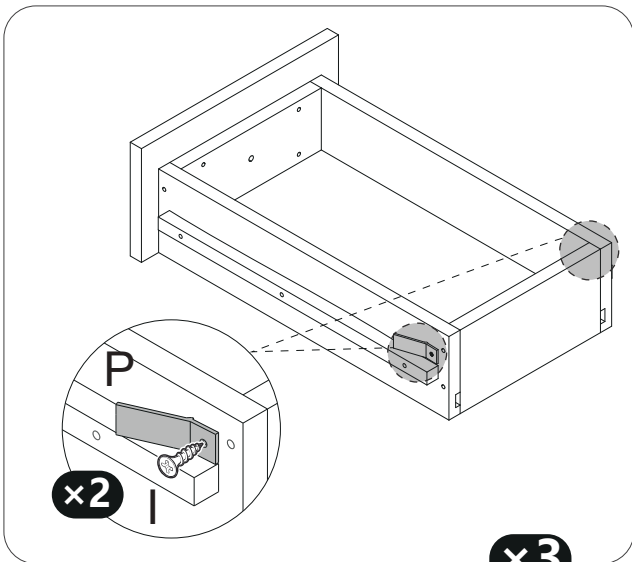

32

I x 6 P x 6

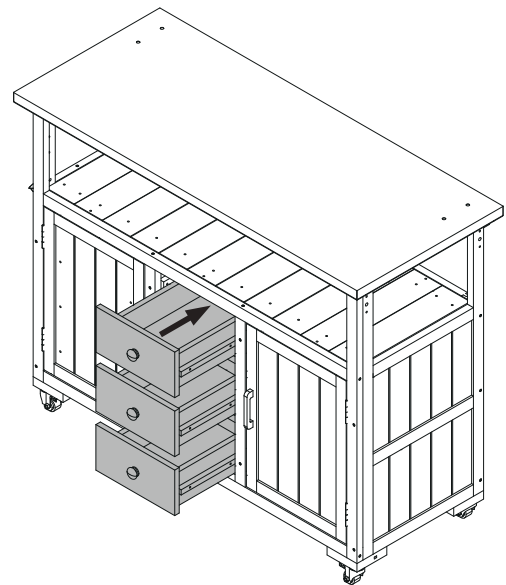

33

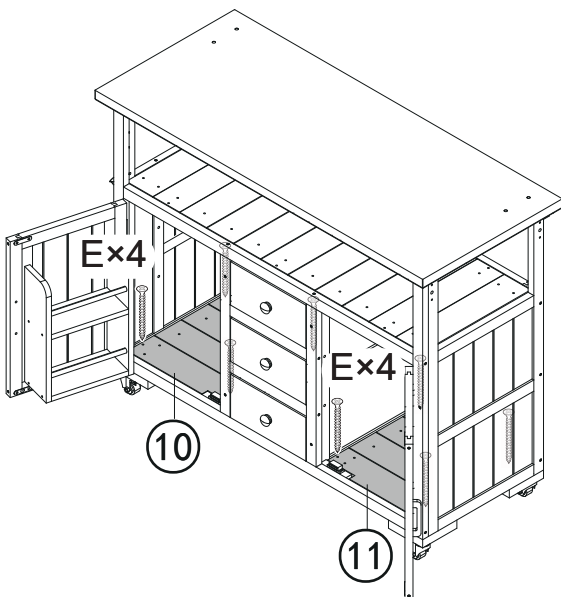

34

E x 8 10 x 1 11 x 1

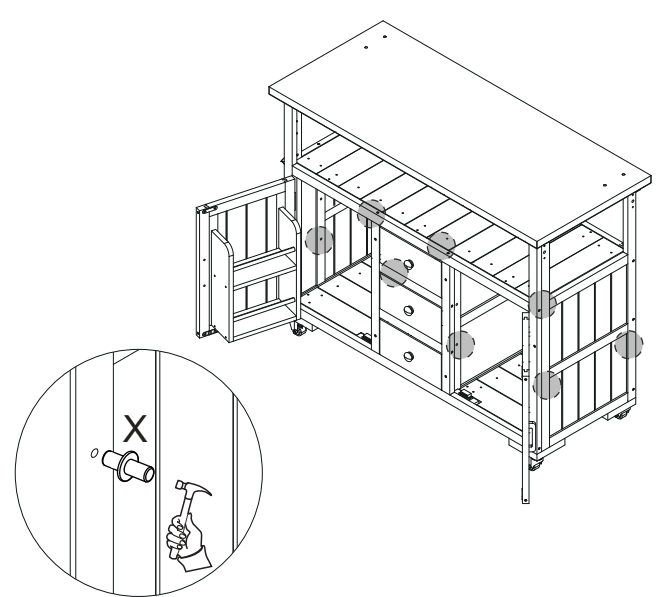

35

X x 8

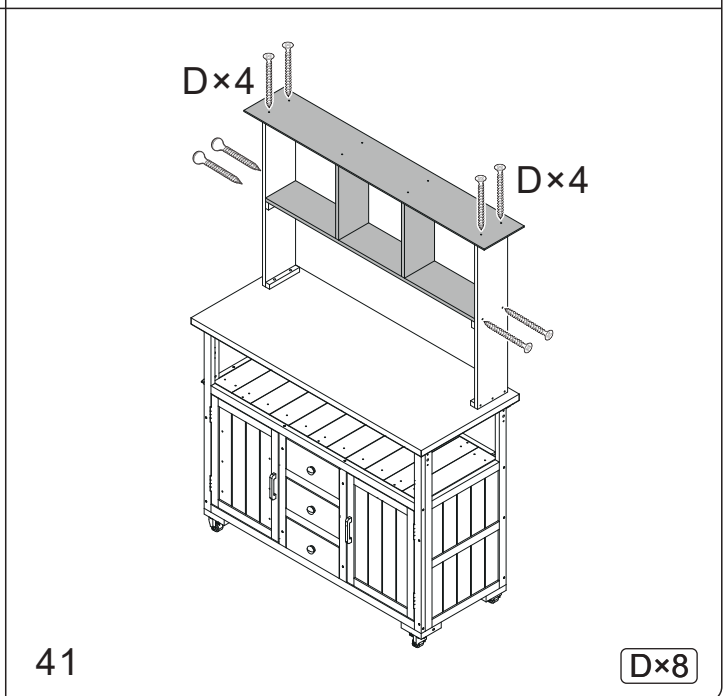
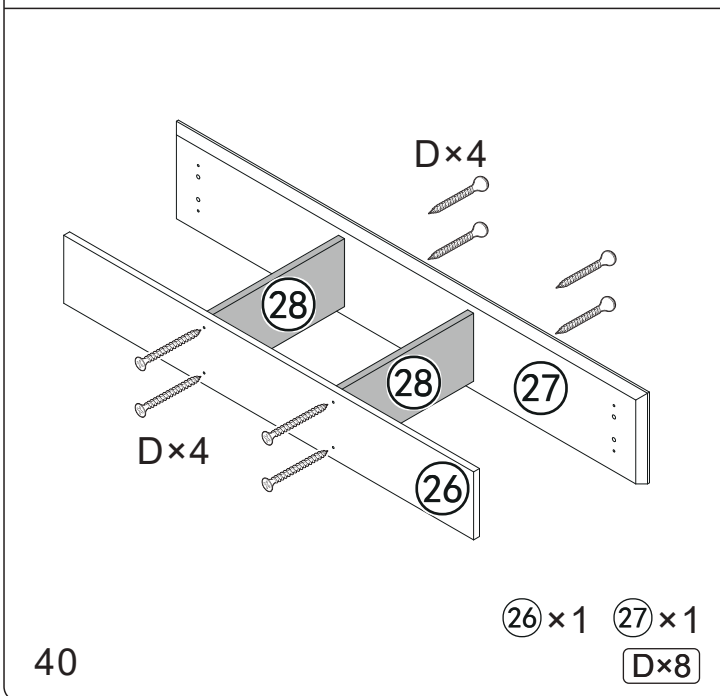
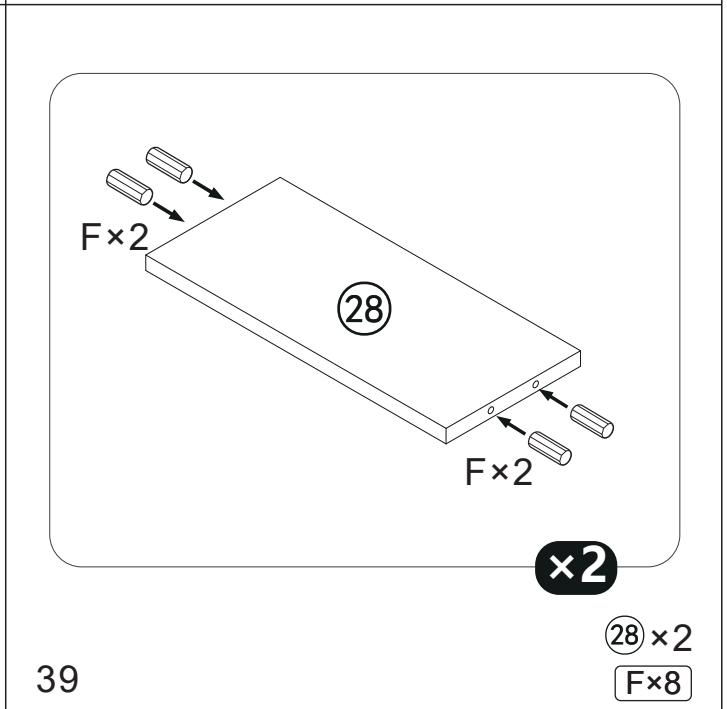
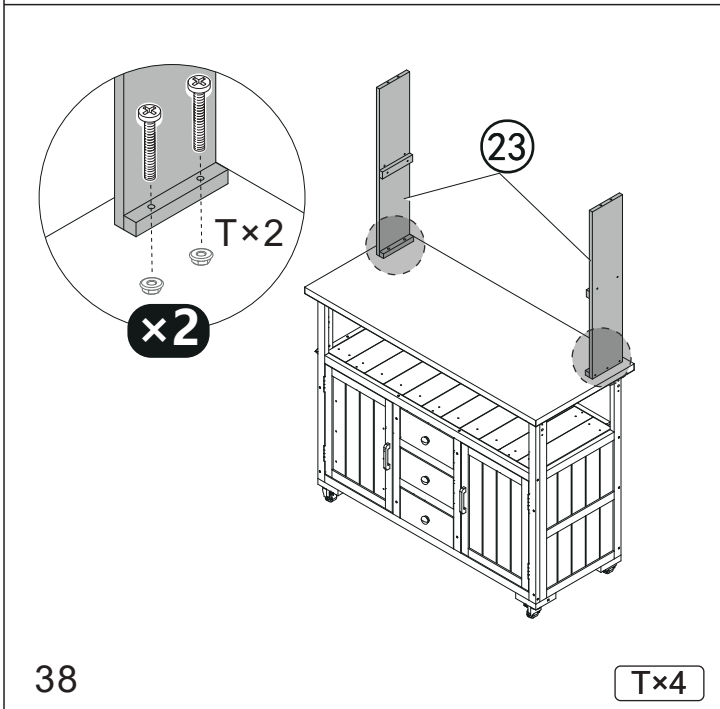
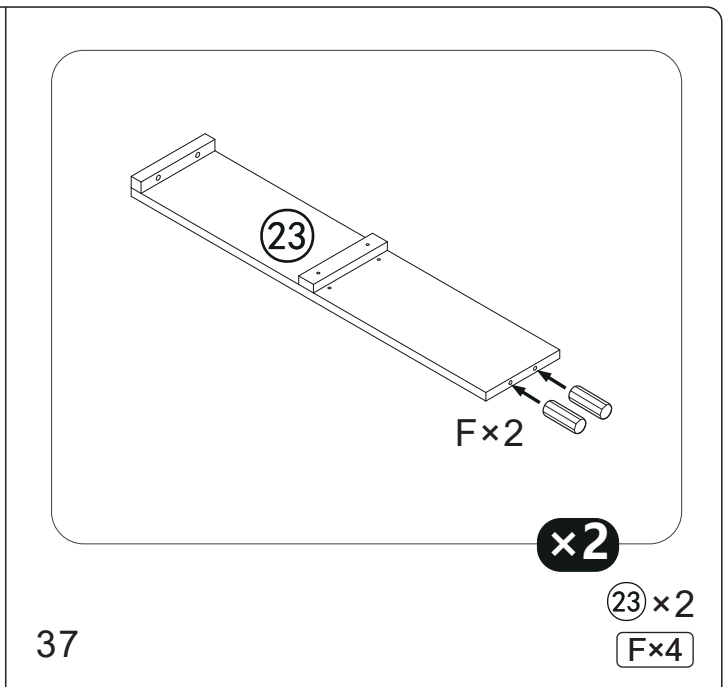
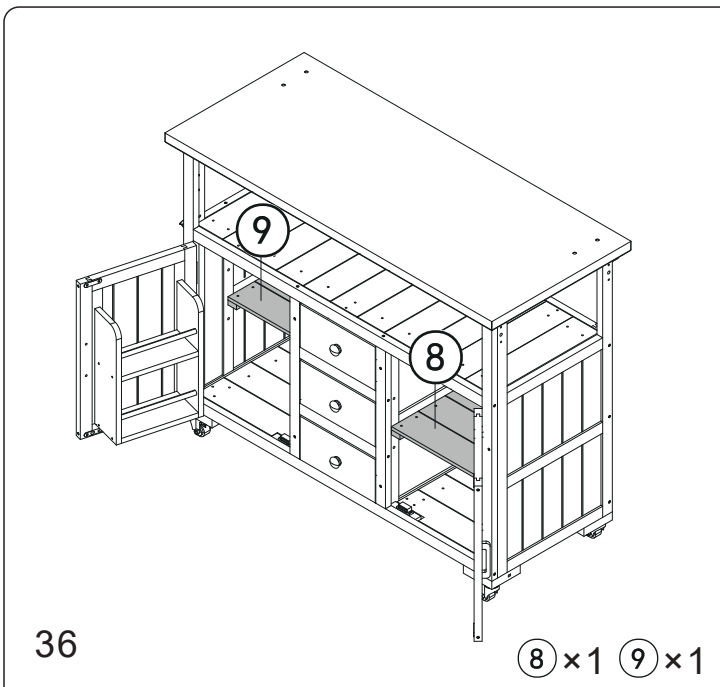

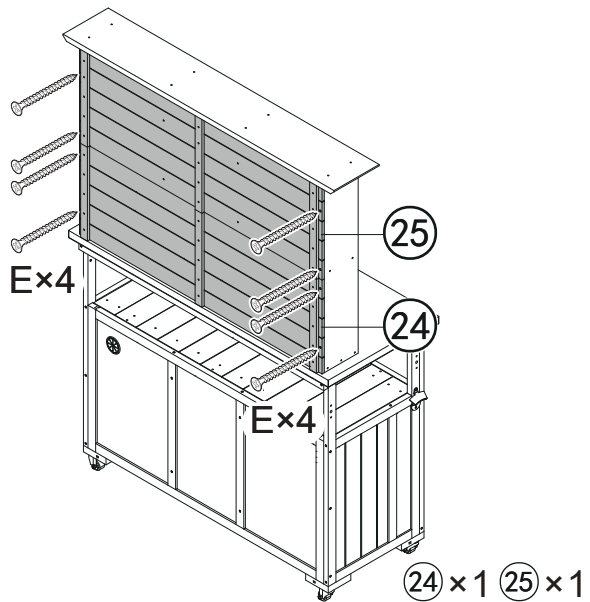

42

(24) x 1 (25) x 1

E x 8

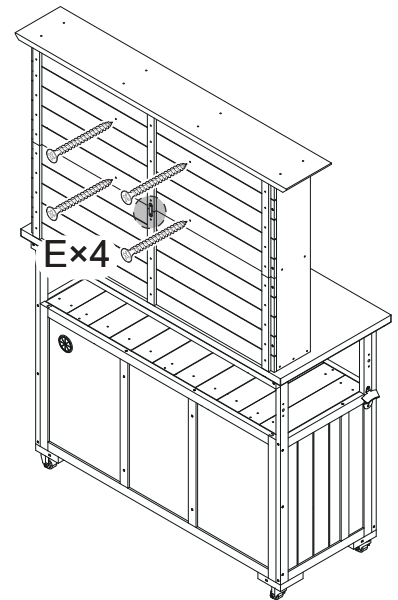
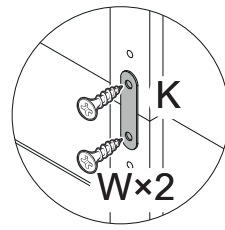

43

E x 4 W x 2 K x 1

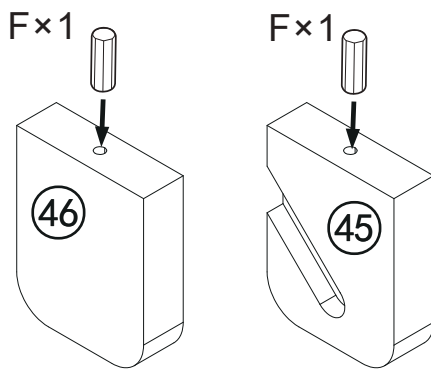

44

(45) x 1 (46) x 1

F x 2

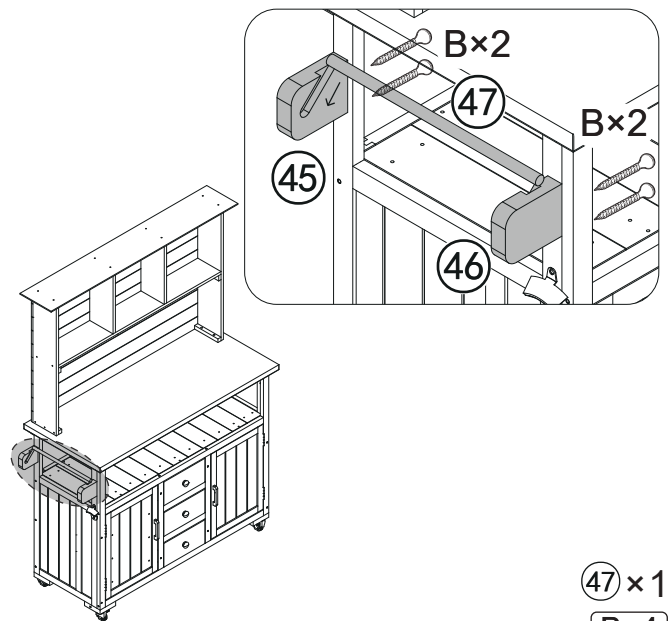

45

(47) x 1

B x 4

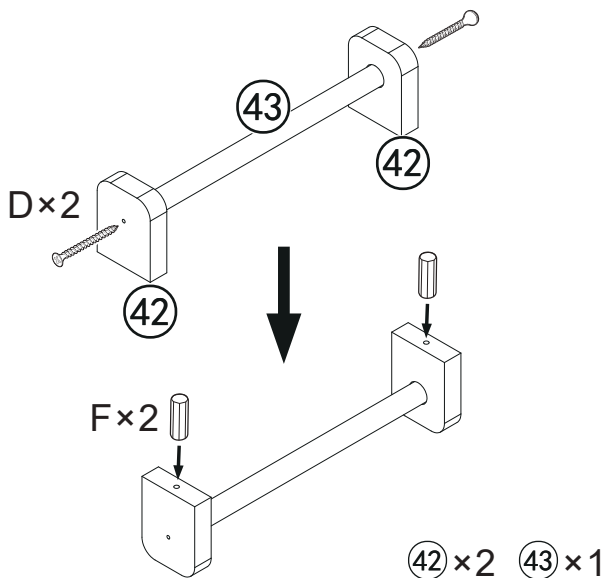

46

(42) x 2 (43) x 1

D x 2 F x 2

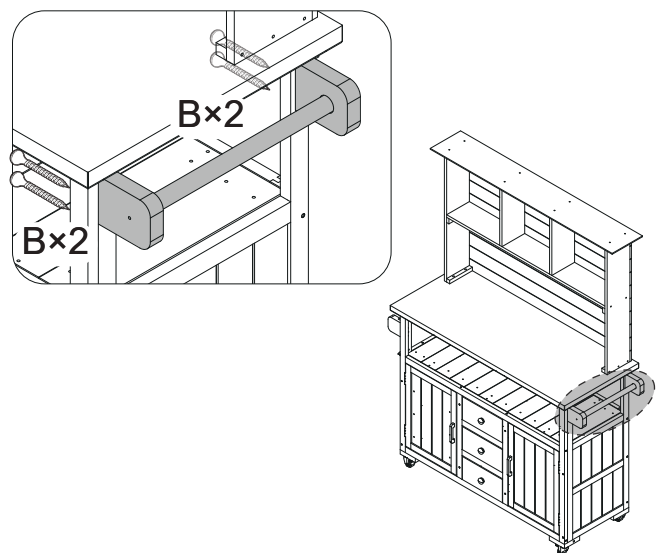

47

B x 4

Fixed Method 1  
Méthode fixe 1

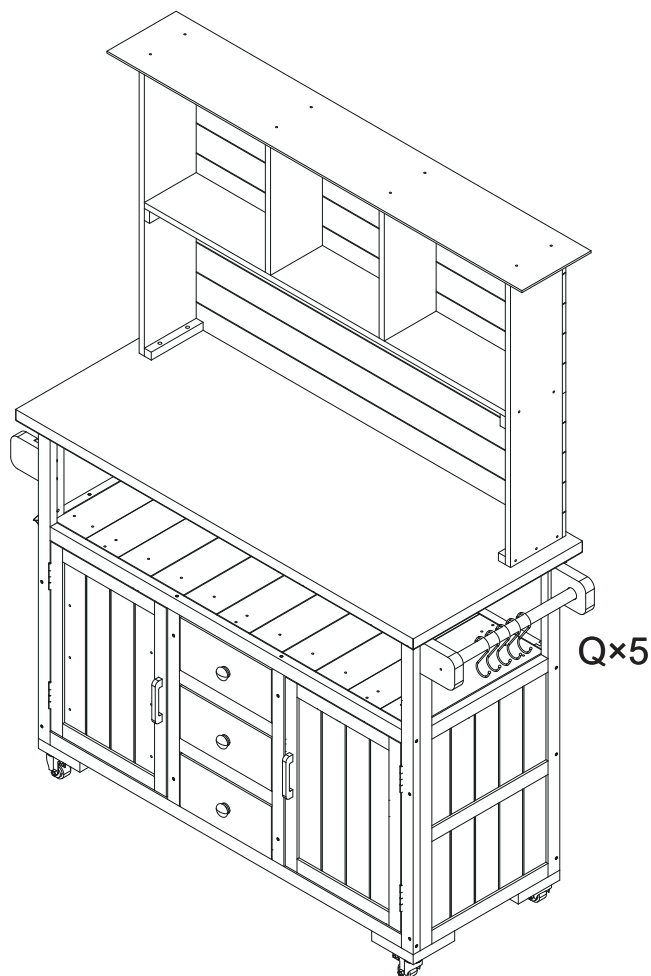

48

Qx5

Fixed Method 2  
Méthode fixe 2

For the fixed method, please choose either 48 steps or 49 steps  
Pour la méthode fixe, veuillez choisir soit 48 étapes soit 49 étapes

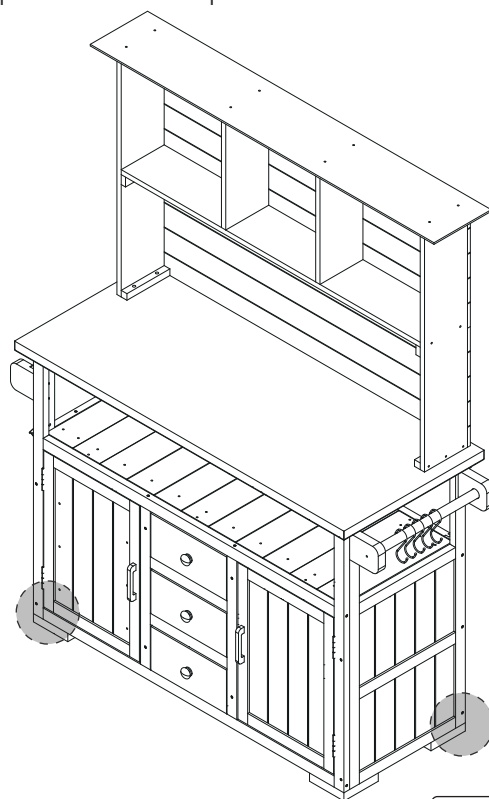
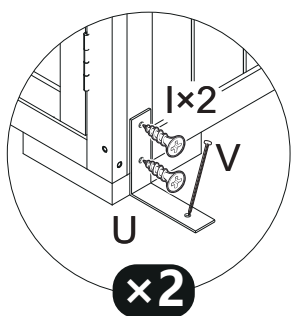

Remove 5 wheels firstly ,then  
assembly L shape metal and nails.  
Retirez 5 roues tout d' abord, puis  
assemblage en forme de L métal et  
clous.

49

I x4 Ux2 Vx2