

# 12X16 Wood Gazebo/Gazebo en Bois

Item/Article #: A1020326H0

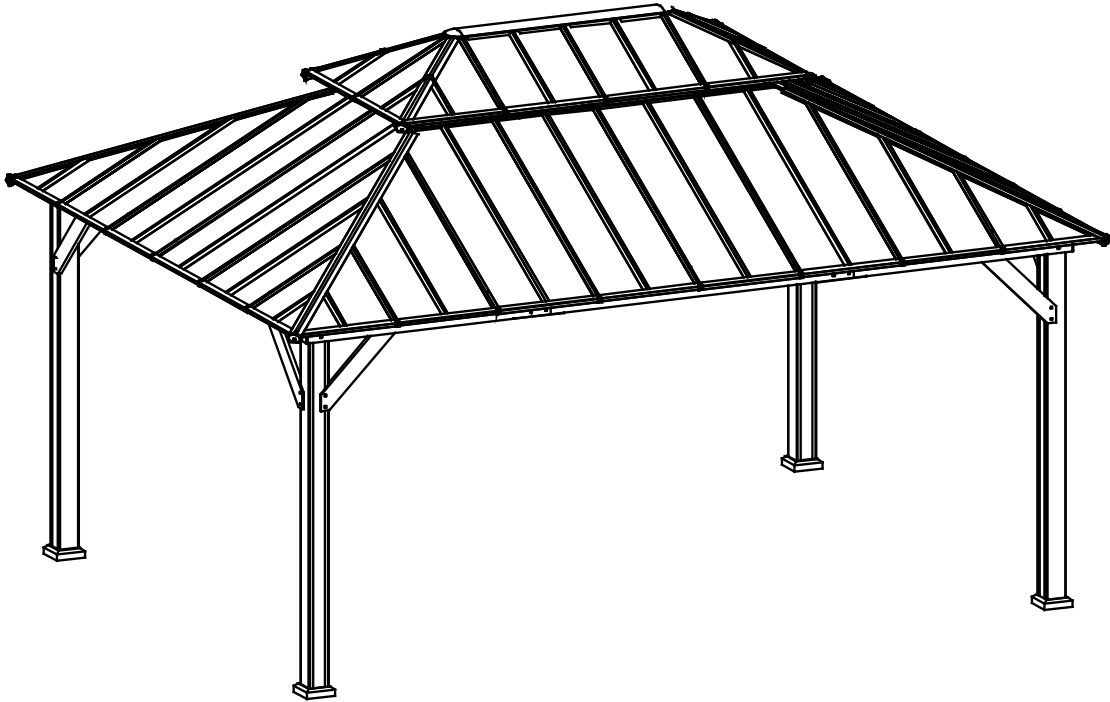

**Questions? Issues? Missing Part? Professional Installation Service?**

**Contact us at [customer.care@sunjoygroup.com](mailto:customer.care@sunjoygroup.com)**

**Questions? Problèmes? Pièce manquante?**

**Service d'installation professionnel? Contactez-nous à [customer.care@sunjoygroup.com](mailto:customer.care@sunjoygroup.com)**



A1020326H025



# 1 \ #  
h # ...

Production Number: 2025101128  
Numéro de fabrication: 2025101128

†

:

least 4 adults. / Tout montage ou entretien du produit doit être effectué uniquement par des adultes.  
V

Please check your state and local regulations prior to purchasing. Some jurisdictions may require permits for installation and use. Some special procedures may be valid in your area. / Veuillez vérifier les réglementations nationales et locales avant d'acheter. Certaines juridictions peuvent exiger des permis pour l'installation et l'utilisation. Certaines procédures spéciales peuvent être valides dans

)

V

@

o

@

)

@

o

surface en béton, utilisez des ancrages adaptés à ces surfaces (ancrages non inclus).

Some parts may contain sharp edges. Wearing protective gloves is #  
contenir des bords tranchants. Portez des gants de protection

Keep children and pets away while setting up u  
l'abri de jardin pendant son assemblage.

# tightened./ Assurez-vous

o

k

thicker than 2 inches. In order to avoid damage, use a plastic snow rake to remove excessive snow

o

épaisse que 2 pouces. Afin d'éviter tout dommage, utilisez un râteau à neige en plastique pour l'accumulation excessive de neige et de glace sur le toit et éloignez-vous des chutes de débris.

This gazebo is intended for decorative and sunshade purposes only and is not designed to withstand #

des fins décoratives et de pare-soleil, et il n'est pas conçu pour résister aux intempéries, notamment

@

to prevent rustin / En



h  
 † # splitti o  
 illustration.  
 h ition )  
 k materials until assembly is compl  
 k @

V (u )  
 †  
 O  
 Consultez l'illustration dans les sché U tte  
 et positionnez-les sur le sol devant  
 Retirez tous les matériels d'emballage tte V

Lisez chaque étape attentivement avant de commencer  
 O  
 V s outi

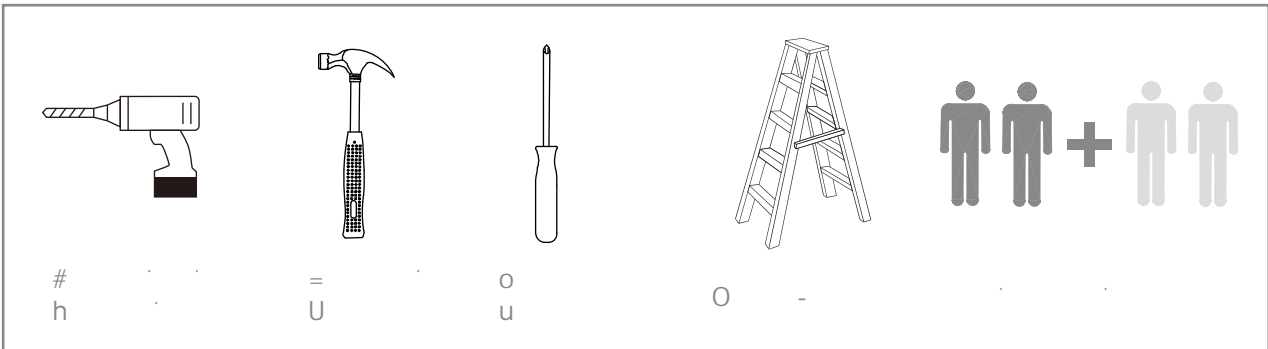

Use this icon to identify information that requires attention. It leads to an unsafe situation. / Cette icône identifie l'information Utili



**Use Level/Utilisez un niveau**

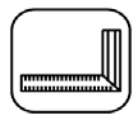

**Square Assembly/Vérifiez avec un équerre**

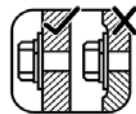

**Tighten Bolts/Serrer les boulons**

Do not overtorque mounting bolts. Over-tightening wood to crack creating splinters and  
 boulons de fixation. Un serrage excessif peut



**Measure Distance/Mesurer la distance**





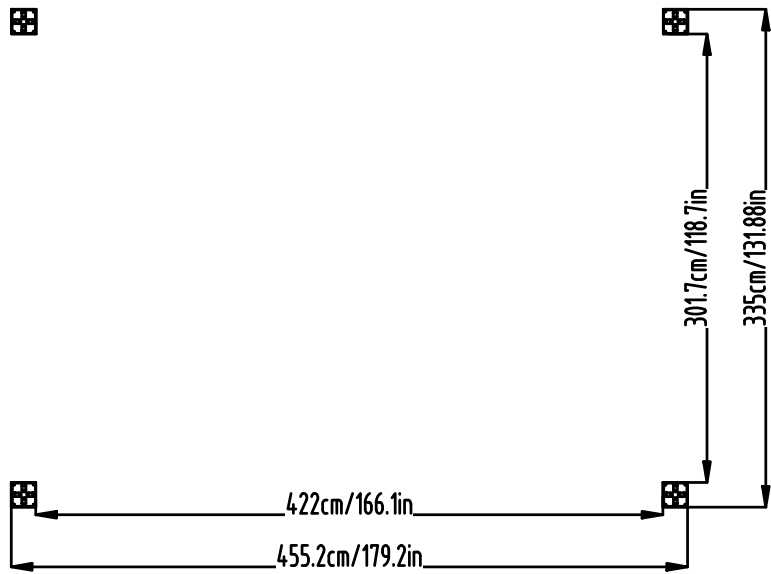



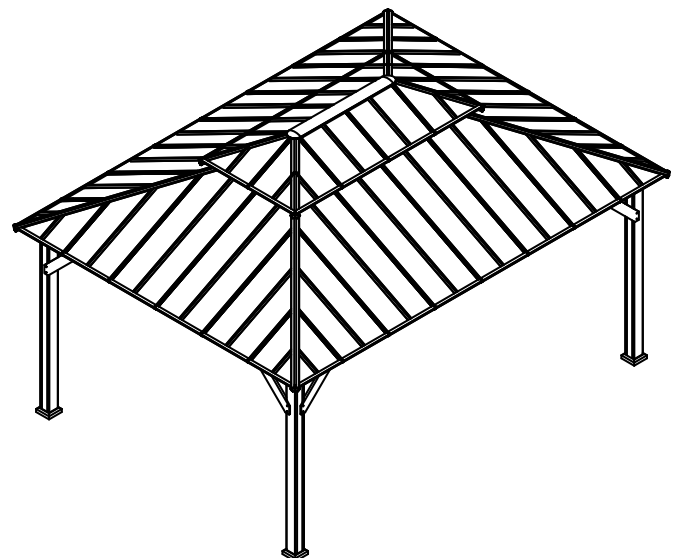
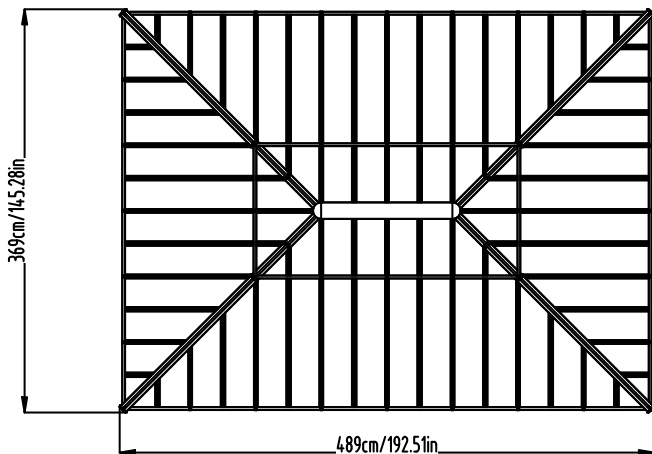
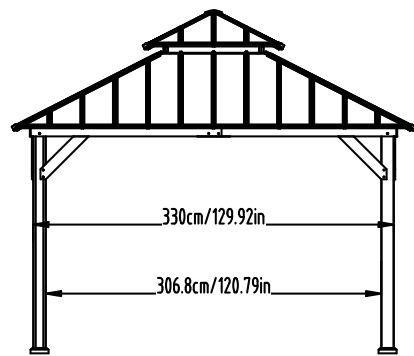
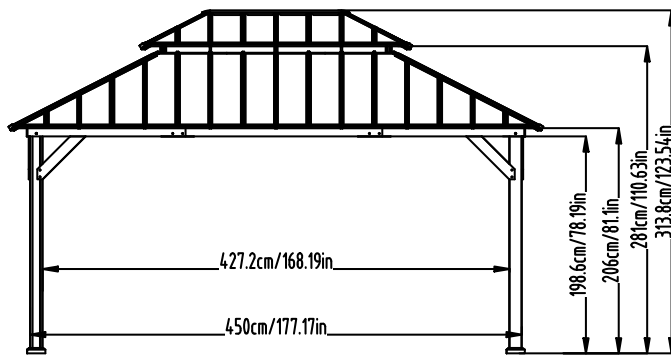

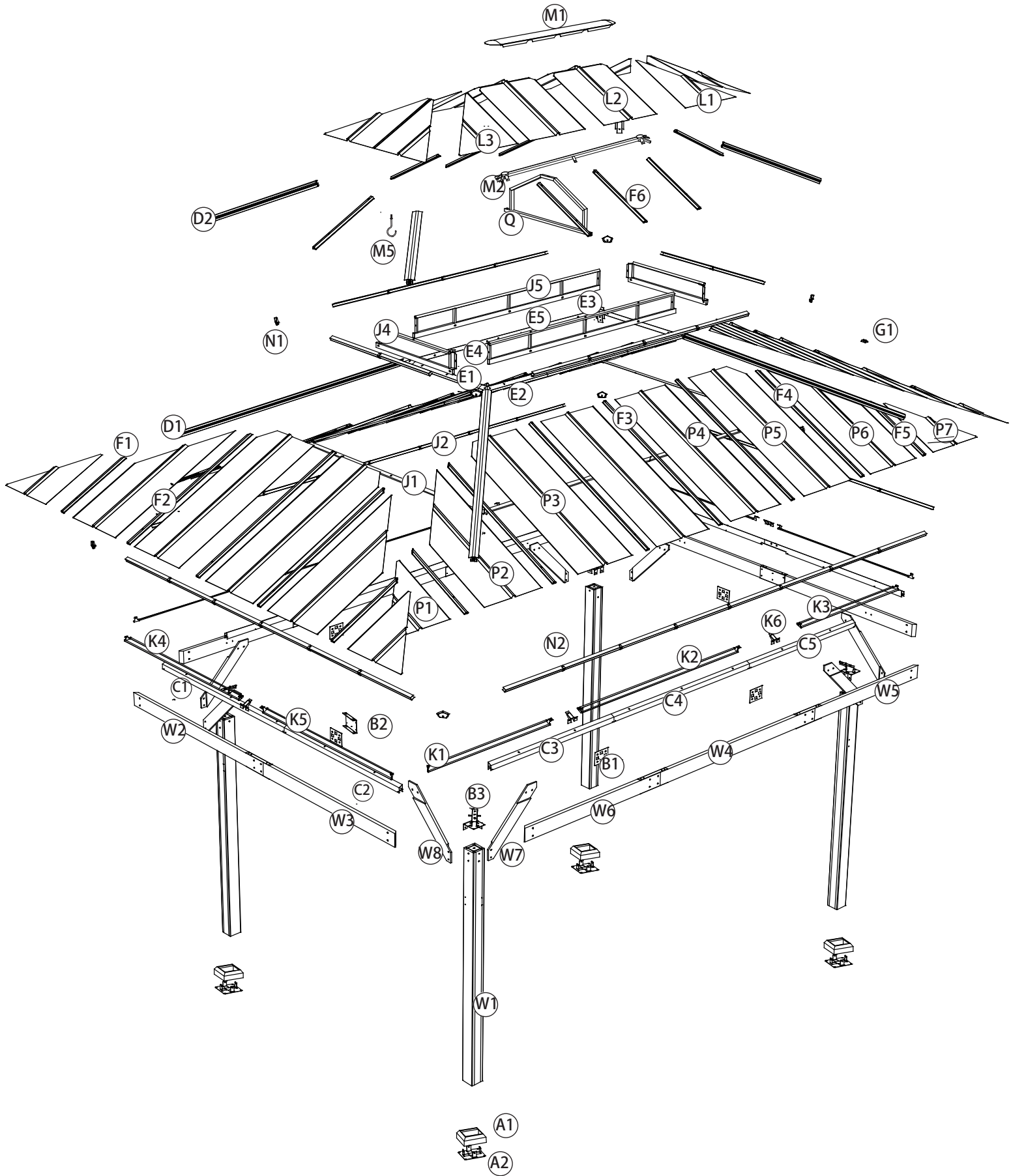











Installation blueprint/  
Plan d'installation

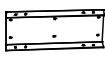

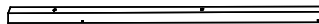

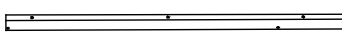

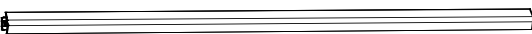



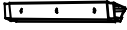

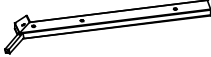











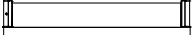
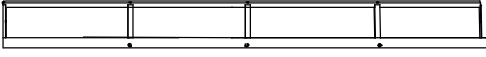





Product size effect drawing/  
Dessin d'effet de taille de  
produit

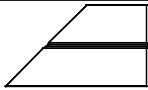

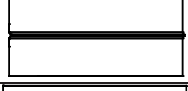

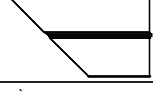

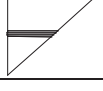
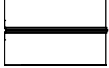
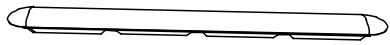
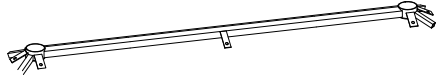
Parts List O h				
Label	Part Number	Description	Qty	Part Image
W1	P00020086801	Post/Poteau	4	
W2	P00040185801	Left Cross Beam(Short Side)/Traverse Gauche (Côté Court)	2	
W3	P00040185901	Right Cross Beam(Short Side)/Traverse Droite (Côté Court)	2	
W4	P00040186203	Middle Cross Beam/ Traverse Centrale	2	
W5	P00040185601	Left Cross Beam(Long Side) /Traverse Gauche (Côté Long)	2	
W6	P00040185701	Right Cross Beam(Long Side)/Traverse Droite (Côté Long)	2	
W7	P00500020003	Brace 1/ Barre de Renfort 1	4	
W8	P00500020103	Brace 2/ Barre de Renfort 2	4	
A1	P00610026903	Base Cover/Barde de la base	4	
A2	P00010026501	Post Base/Base du Poteau	4	
B1	P00220056501	Inner Cross Beam Cap/ Capuchon de traverse intérieure	6	
B2	P00220056601	Cross Beam Cap/ Capuchon De la Traverse	6	
B3	P00050245101	Rafter Connector/ Connexion du Chevron	4	
C1	P00050245201	Short Cross Beam Connector 2/Connecteur de poutre transversale courte 2	2	
C2	P00050245301	Short Cross Beam Connector 1/Connecteur de poutre transversale courte 1	2	
C3	P00050245401	Long Cross Beam Connector 1/Connecteur de poutre transversale longue 1	2	
C4	P00050245501	Long Middle Cross Beam Connector/Connecteur de poutre transversale longue et moyenne	2	
C5	P00050245601	Long Cross Beam Connector 2/Connecteur de poutre transversale longue 2	2	
D1	P00060331501	Big Roof Rafter/Chevron du Grand Toit	4	
D2	P00060331601	Small Roof Rafter/ Plafond du Petit Toit	4	





Parts List O h				
Label	Part Number	Description	Qty	Part Image
E1	P00050245701	Big Roof Short Frame/ Structure Courte du Grand Toit	2	
E2	P00050246301	Big Roof Corner Frame 1/Cadre d'angle de grand toit 1	2	
E3	P00050245801	Big Roof Corner Frame 2/ Cadre d'angle de grand toit 2	2	
E4	P00050245901	Big Roof Corner Frame Connector 1/Connecteur de cadre d'angle pour grand toit 1	4	
E5	P00050246001	Big Roof Long Frame/ Structure Longue du Grand Toit	2	
F1	P00060331701	Big Roof Small Beam (Left)/ Petite Poutre du Grand Toit (Gauche)	4	
F2	P00060331801	Big Roof Long Beam (Left)/ Poutre Longue du Grand Toit (Gauche)	4	
F3	P00060331901	Big Roof Long Middle Beam/ Grand toit Longue poutre centrale	8	
F4	P00060332001	Big Roof Long Middle Beam (Right)/Grand toit Longue poutre centrale(Droit)	4	
F5	P00060332101	Big Roof Small Middle Beam (Right)/Poutre Centrale Petite du Grand Toit(Droit)	4	
F6	P00060332201	Small Roof Middle Beam / Poutre Centrale du Petit Toit	8	
G1	P00050246201	Middle Beam Connector/ Connexion de la poutre centrale	4	
G2	P00050242801	Small Beam Connector/ Connecteur pour petit faisceau	4	
J1	P00060306601	Long Small Beam/ Poutre Petite Longue	4	
J2	P00060306701	Middle Small Beam/ Moyenne Petite poutre	2	
J5	P00500101201	Support Frame 2 Structure de support 2	2	
J6	P00500101101	Support Frame 1 Structure de support 1	2	

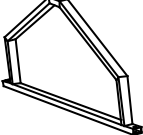



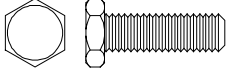
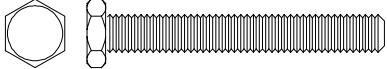

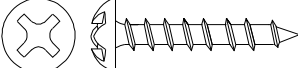
Parts List O h				
Label	Part Number	Description	Qty	Part Image
K1	P00570049701	Long Mosquito Netting Rod 1/Tringle Longue du Filet Moustiquaire 1	2	
K2	P00570049801	Middle Mosquito Netting Rod/Tige de moustiquaire intermédiaire	2	
K3	P00570049901	Long Mosquito Netting Rod 2/Tringle Longue du Filet Moustiquaire 2	2	
K4	P00570050001	Short Mosquito Netting Rod 1/Tringle Courte du Filet Moustiquaire 1	2	
K5	P00570050101	Short Mosquito Netting Rod2 /Tringle Courte du Filet Moustiquaire 2	2	
K6	P00050246401	Mosquito Netting Rod Connector /Connecteur de tige de moustiquaire	6	
P2	P00070162801	Big Roof Right Middle Roof Panel /Grand toit Panneau central droit du toit	4	
P3	P00070162901	Big Roof Right Big Roof Panel/Grand toit droit Grand panneau de toit	4	
P4	P00070163001	Big Roof Big Roof Panel/ Grand toit Grand panneau de toit	4	
P5	P00070163101	Big Roof Left Roof Panel/ Panneau de Toiture Gauche du Grand Toit	4	
P6	P00070163201	Big Roof Left Middle Roof Panel /Panneau de Toiture Central Gauche du Grand Toit	4	
L1	P00070162401	Small Roof Left Small Roof Panel/Panneau Petit Gauche du Petit Toit	8	
L3	P00070162501	Small Roof Right Small Roof Panel /Petit toit droit Petit panneau de toit	8	
L2	P00070162601	Small Roof Big Roof Panel/ Petit toit Grand toit Panneau	4	
M1	P00090024401	Small Roof Cover/Petite couverture de toit	1	
M2	P00050246501	Small Roof Connector/ Connexion du petit toit	1	
M5	P00580015401	Hook/Crochet	2	

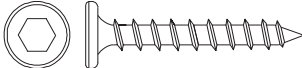
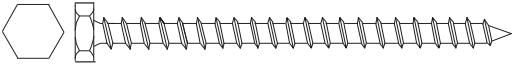
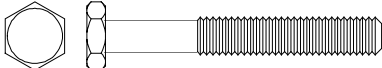
## Parts List O h

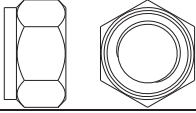
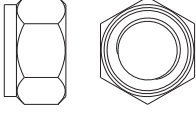
Label /	Part Number h	Description	Qty j	Part Image h )
N3	P00220056801	Faxed Part For U Shape Beam Cap / Pièce faxée pour chapeau de poutre en U	32	
N2	P00220056901	U Shape Beam Cap / Capuchon de poutre en forme de U	40	
N1	P00220057001	Corner Beam Cap / Couvert de la Poutre du Coin	8	
Q	P00220057101	Support Frame / Structure de support	1	

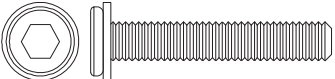
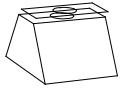
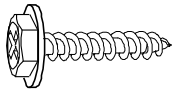
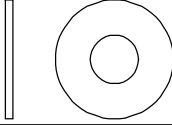
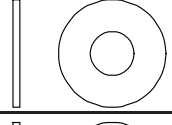
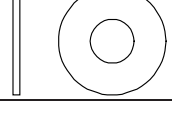
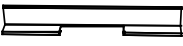
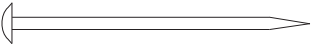
## Hardware Pack h j

Label /	Part Number h	Description	Qty j	Add	Part Image h )
=	H010010084	" U 20 " U 20	62	3	
=	H010010098	" U " U	86	3	
=	H100010179	" U U 65 " U 65	8	1	
=	H030071207	o ou † ou	44	1	
=	H030071109	Screw ou † s ST4.8*25	128	7	
H6	H030030013	Screw ou † ST8*35	32	2	
H7	H030010132	o ou 60 † ou 60	8	1	
H19	H010010009	" U 40 " U 40	1	0	

Hardware Pack h j					
Label /	Part Number h	Description	Qty j	Add	Part Image h )
=1	H040050029	V U6 / U6	10	1	
=	=	V U / U	8	1	
=	=	uV U uV U	24		
=	=	U ) Fo retM3			
=	H100040020	" U " U	24		
=	=	‡ k # k	12	1	
=	H100100001	o ou † ou	40		
H14	H050030003	7 U k h U	16	2	
=	H050030002	7 k h U	32	2	
=	H050030001	7 k h U	163	9	
=	h	h h	16		
=o	=	o h	8		
=‡ 1	H090990008	° M U # U	1		
=‡	H090030005	Allen Wrench M8 /Clé Allen M8	1		
=‡	=	Wrench M10/ Clé M10			
=‡ 4	H090010017	Wrench M6/ Clé M6	1		

1

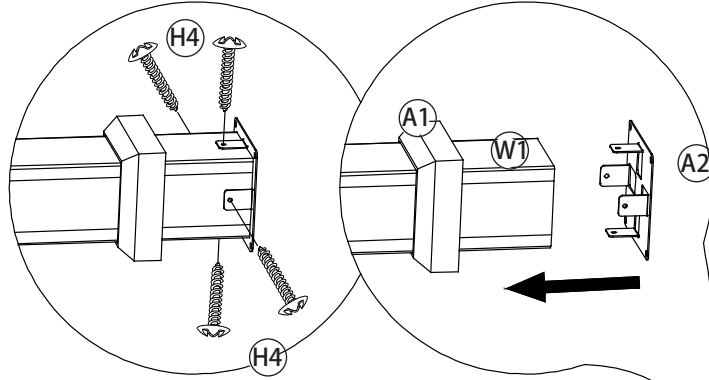
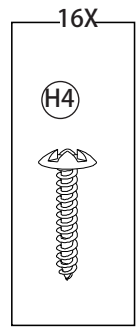
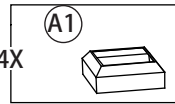
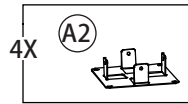

2

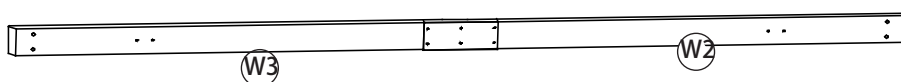
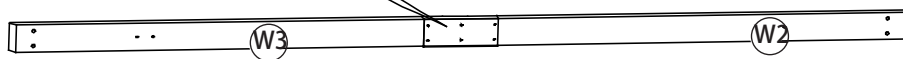
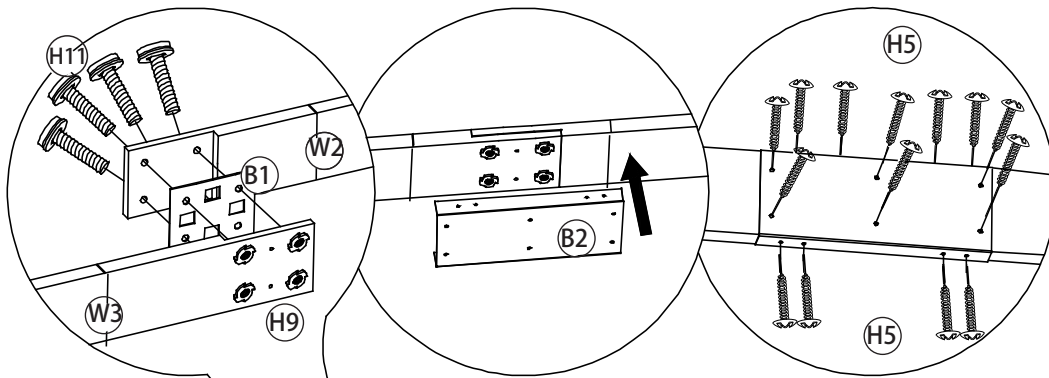
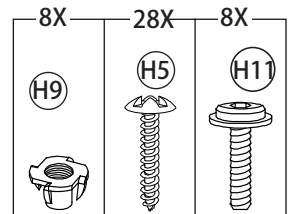
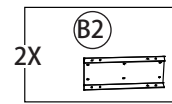
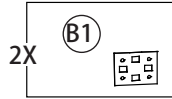

# 3

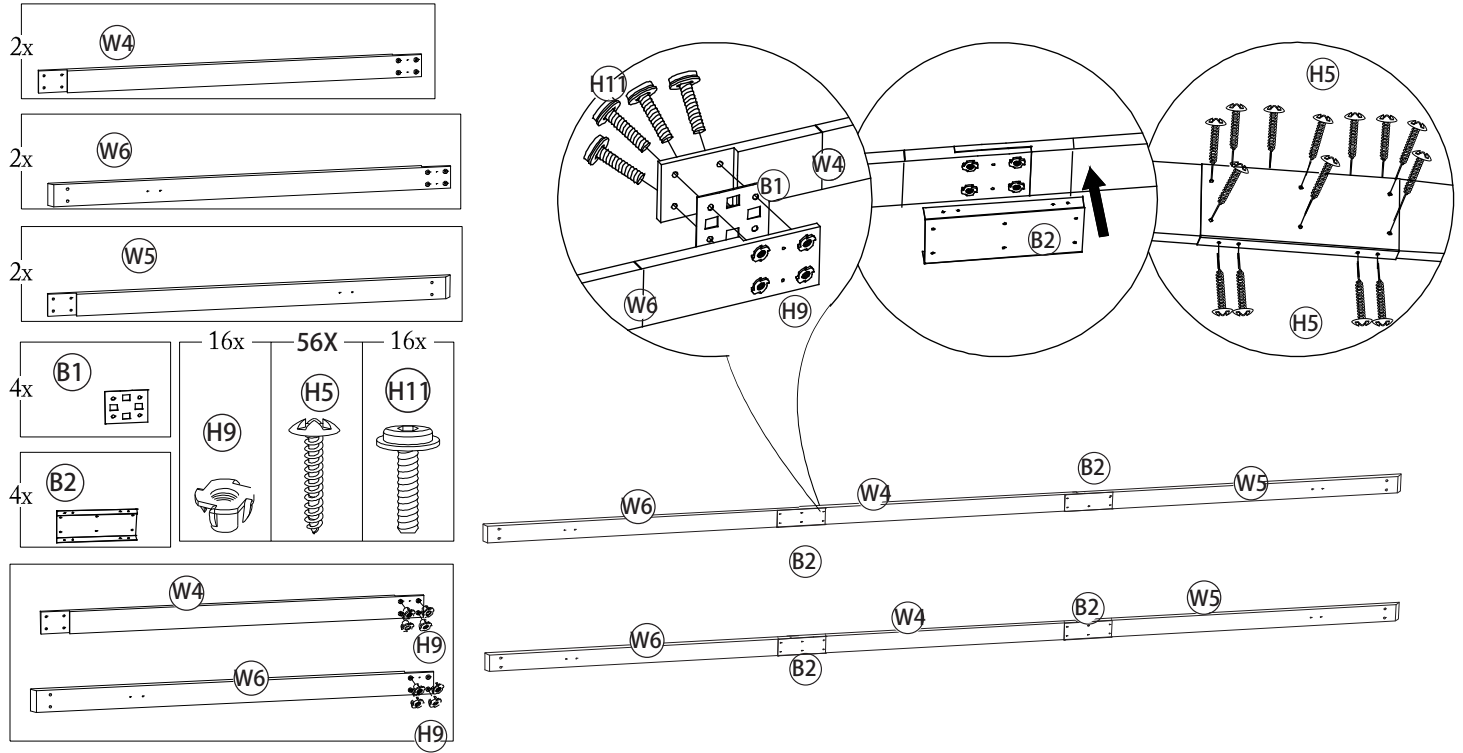

# 4

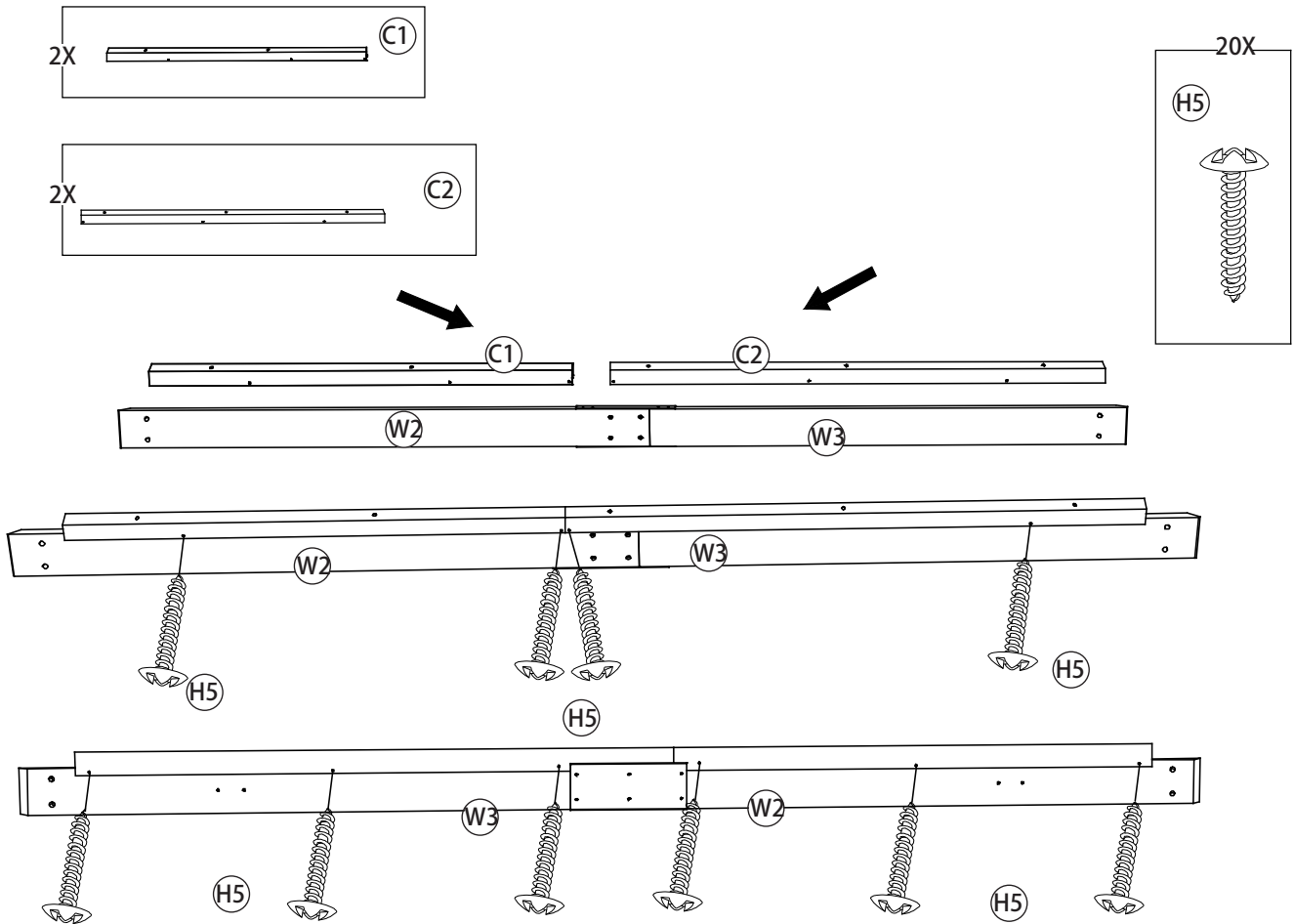

5

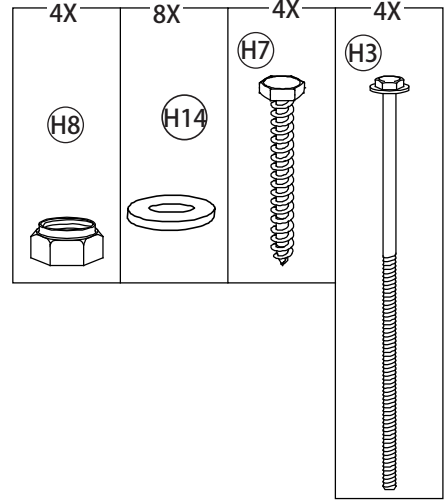
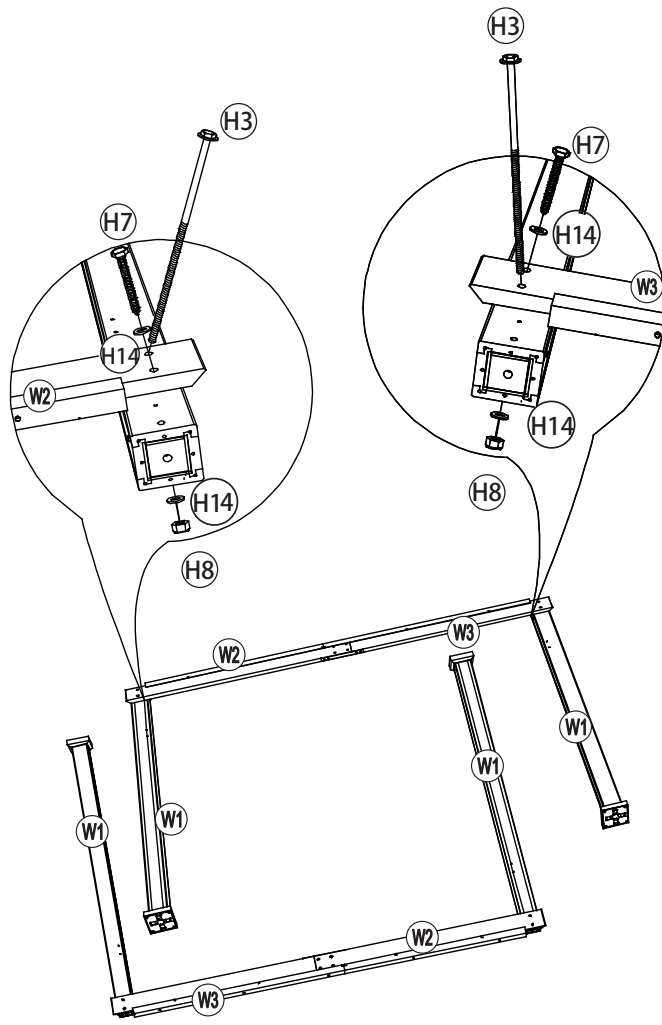

6

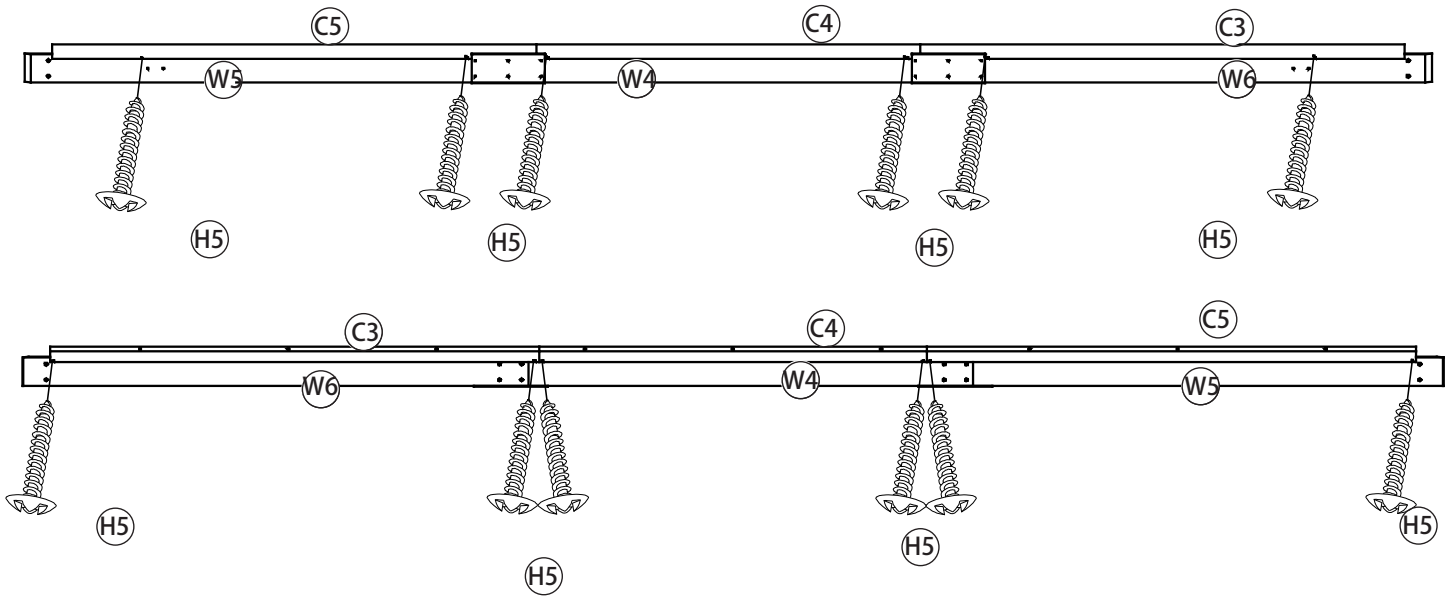
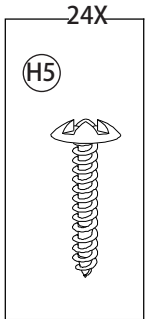
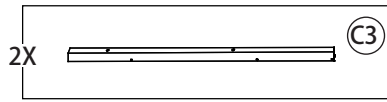
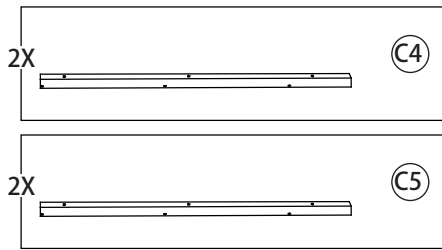

# 7

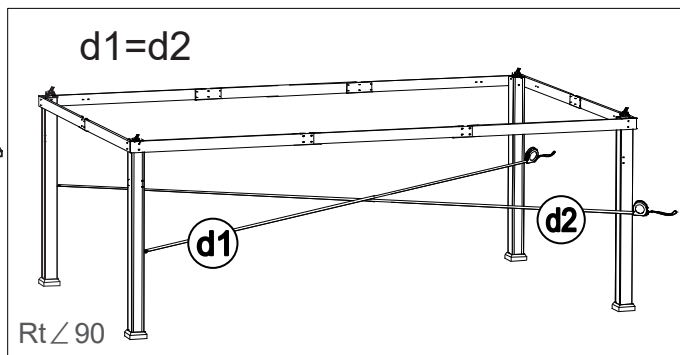
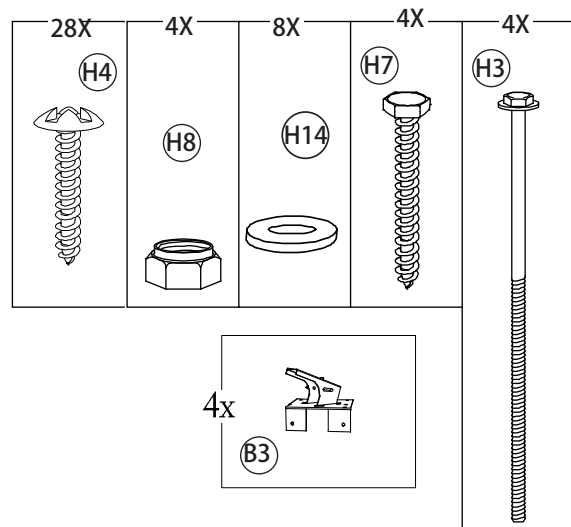
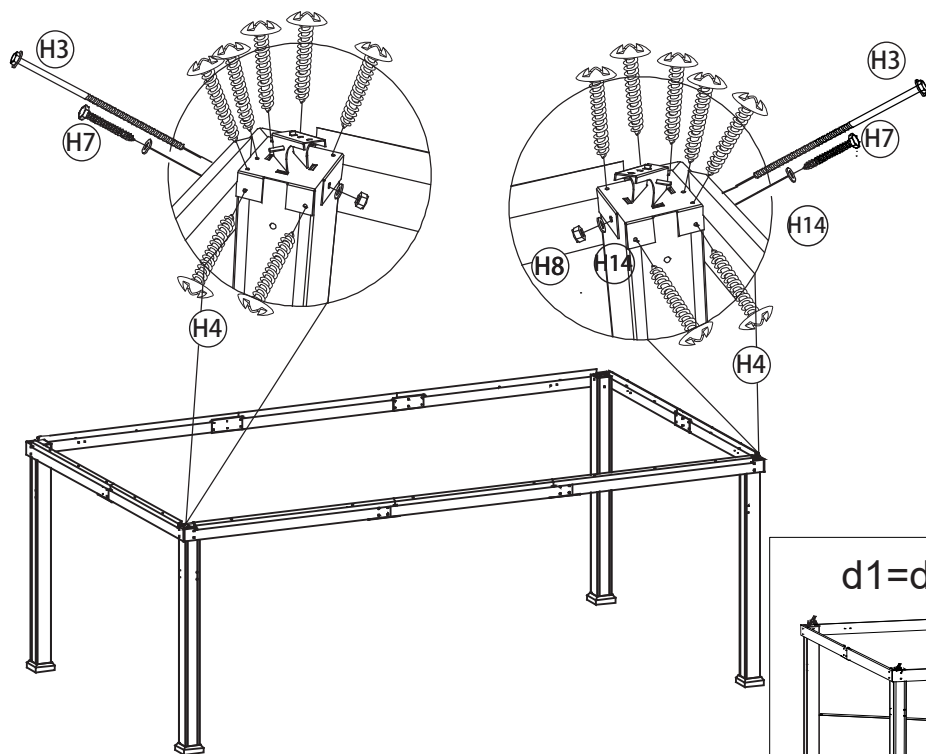

# 8

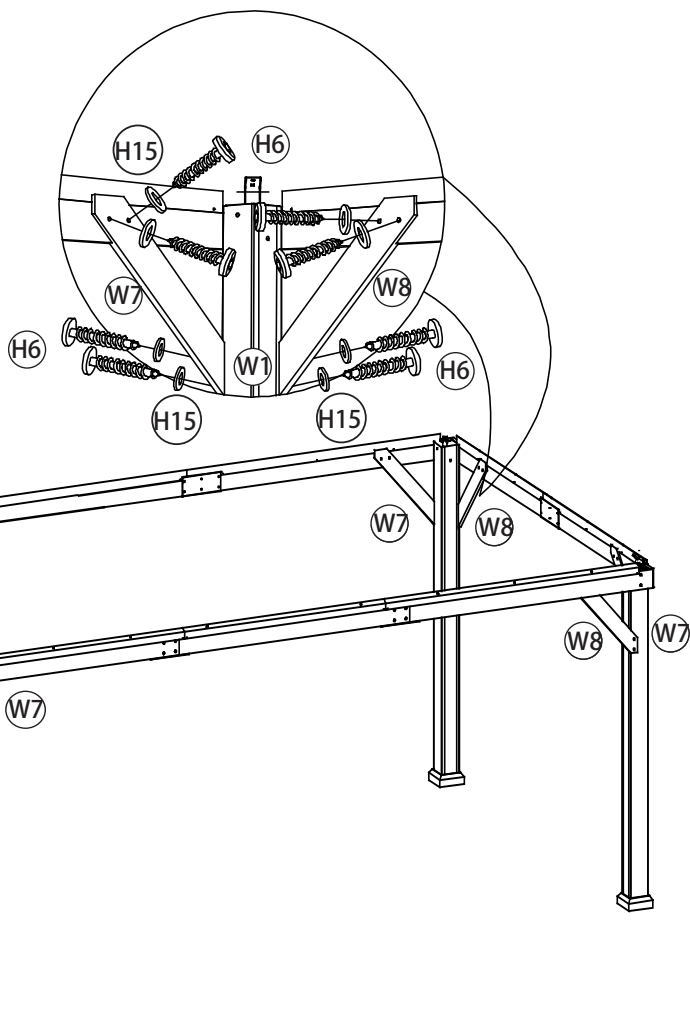
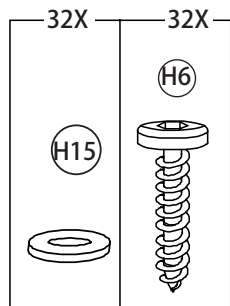
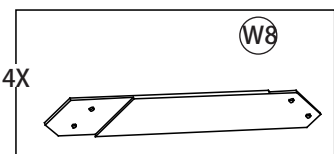
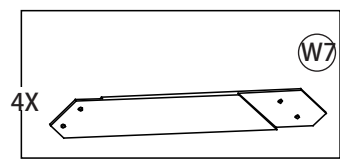

9

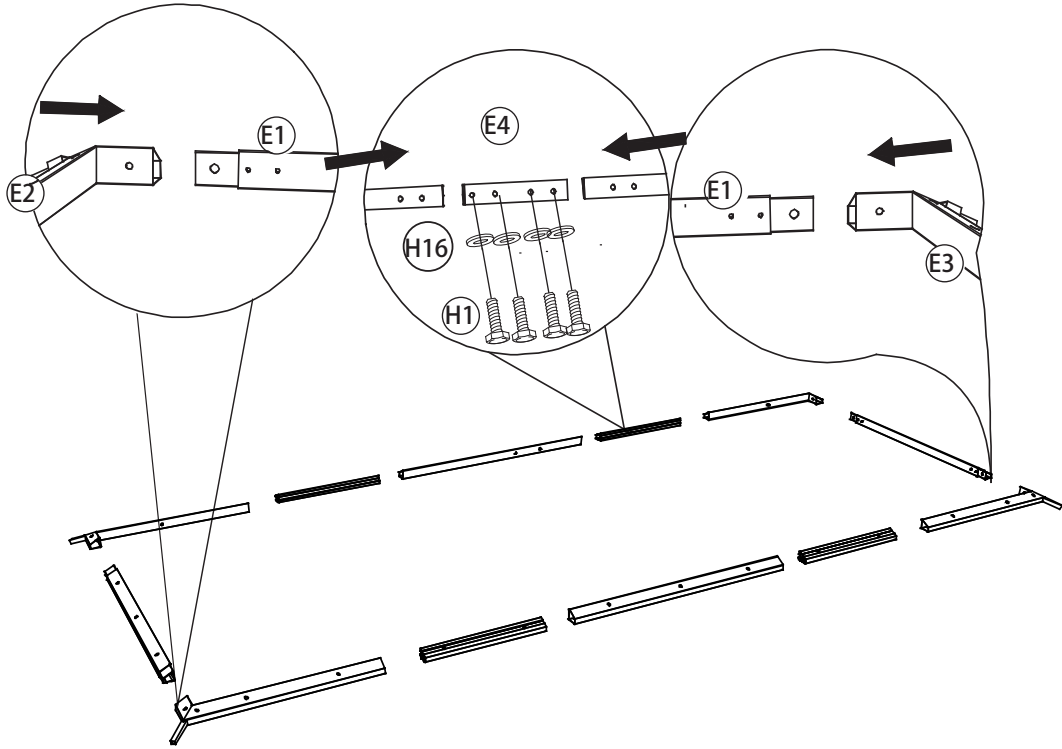
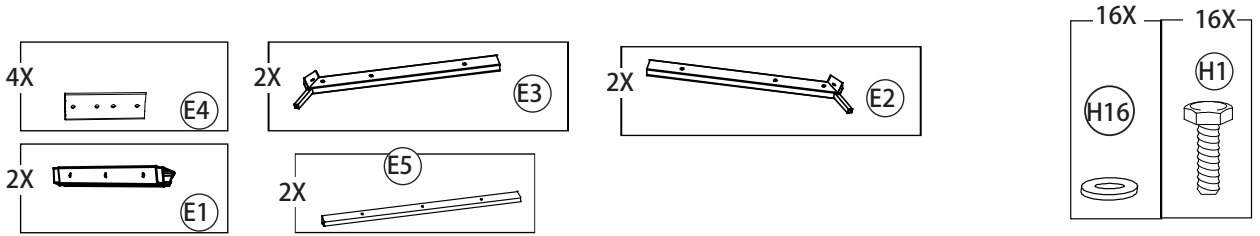

10

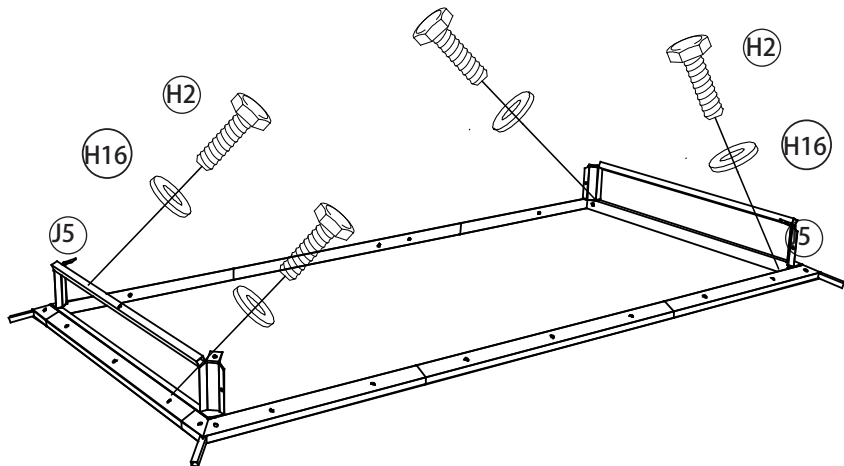
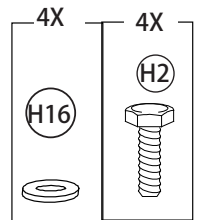
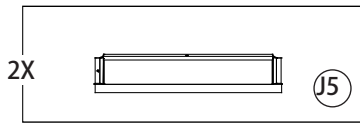

# 11

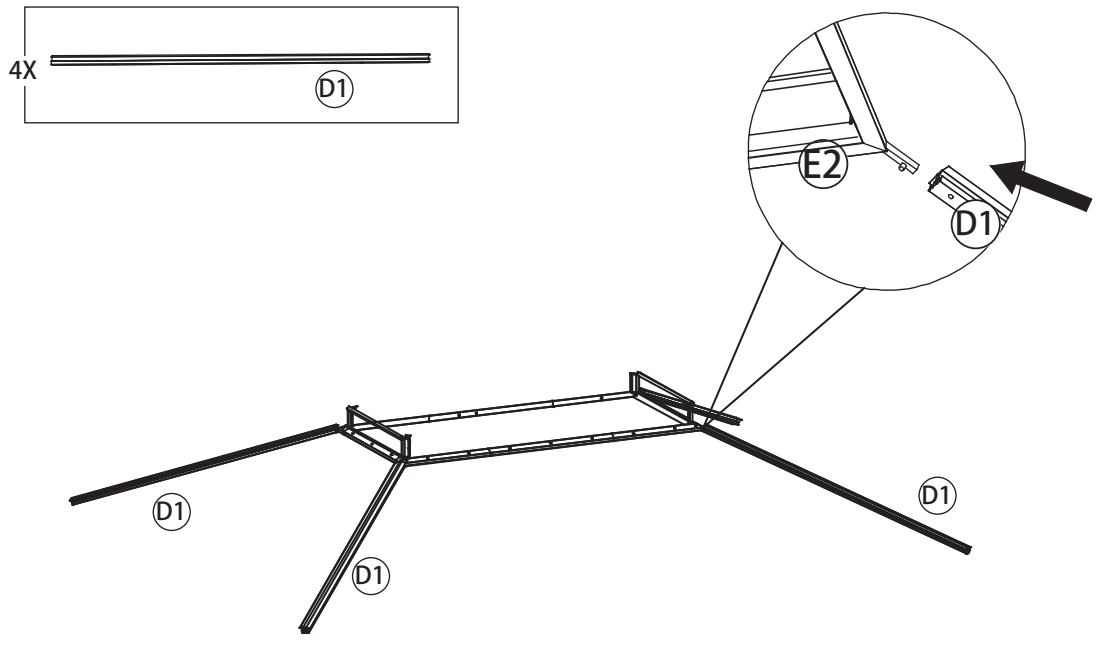

# 12

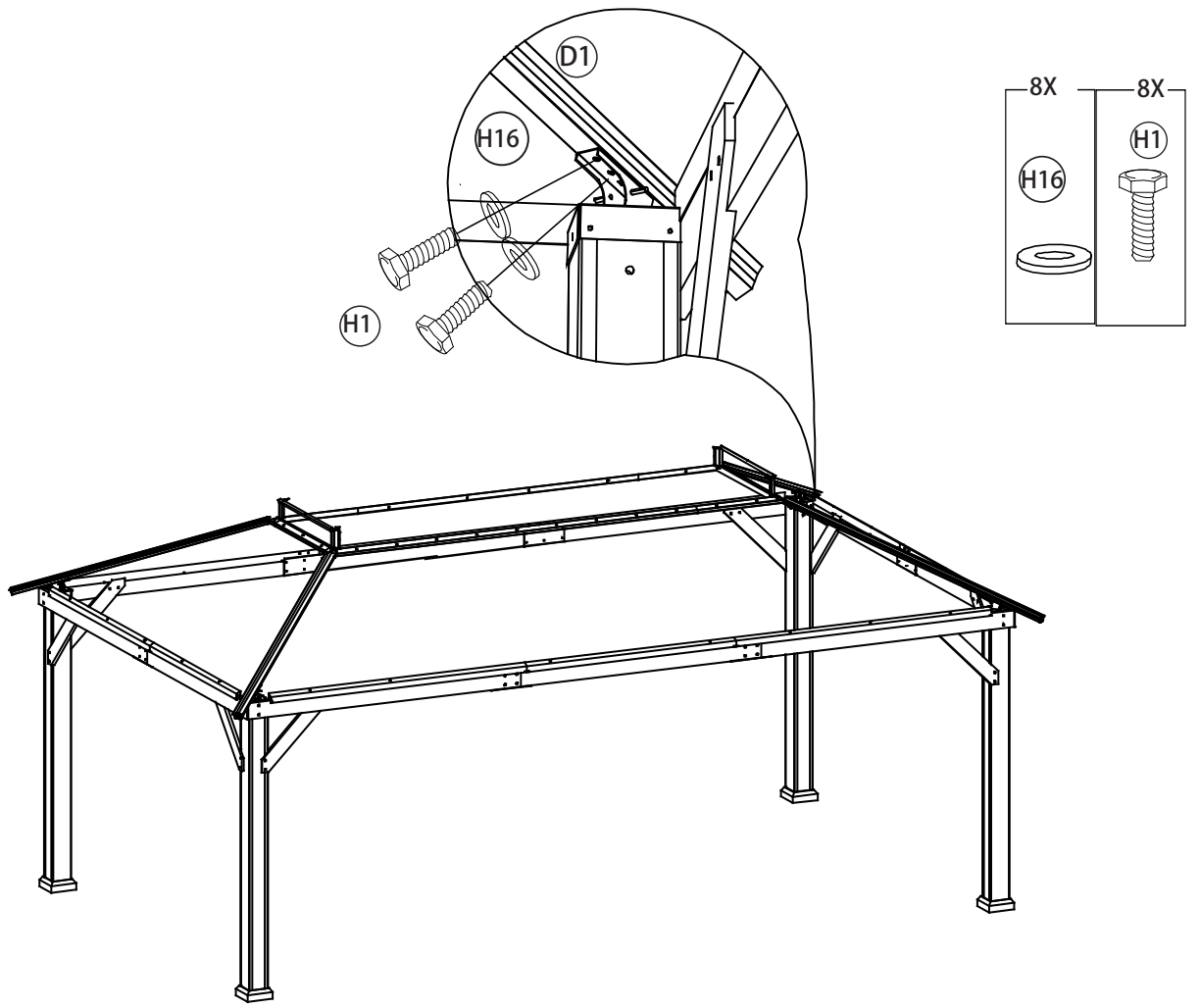

# 13

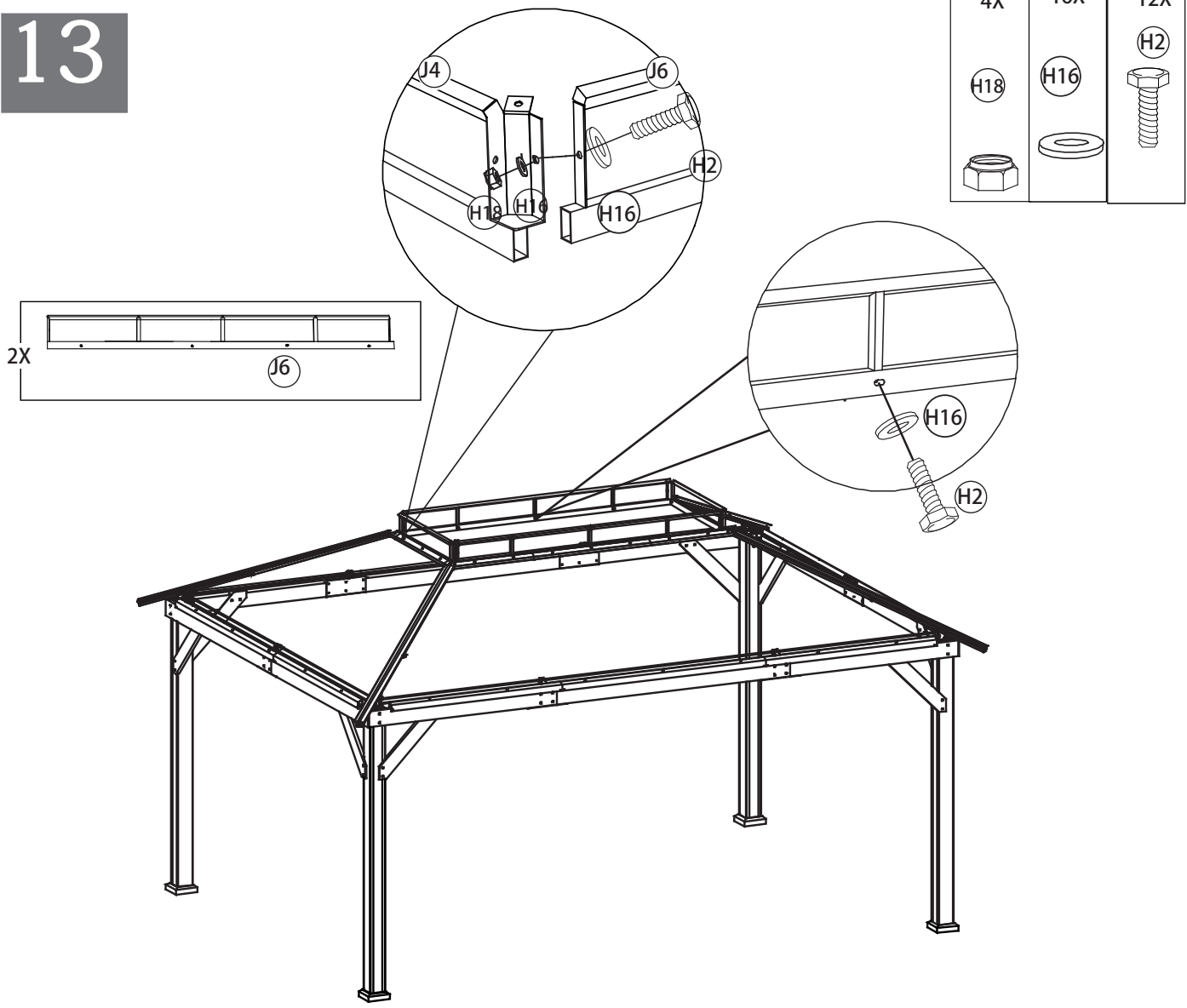

# 14

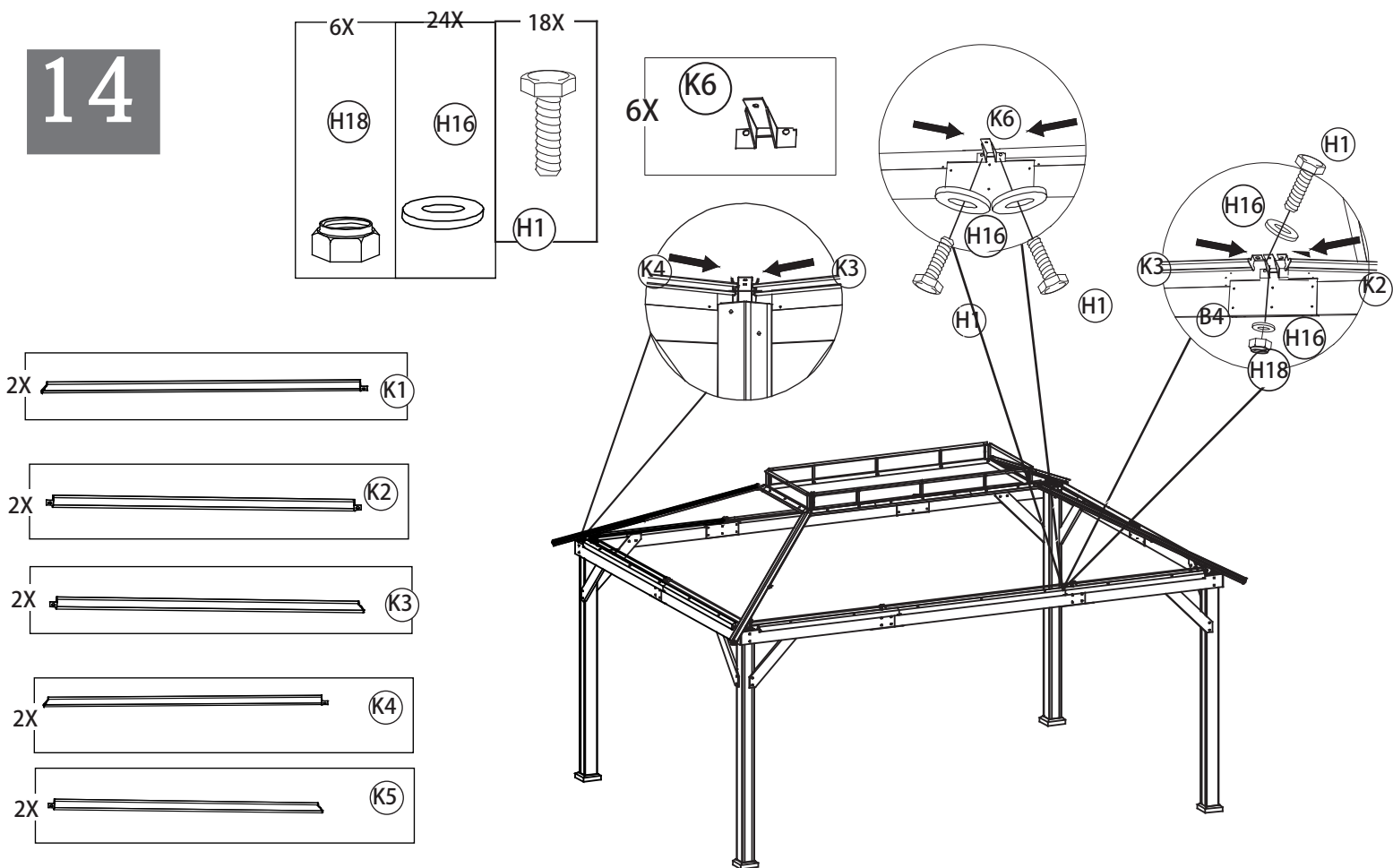

# 15

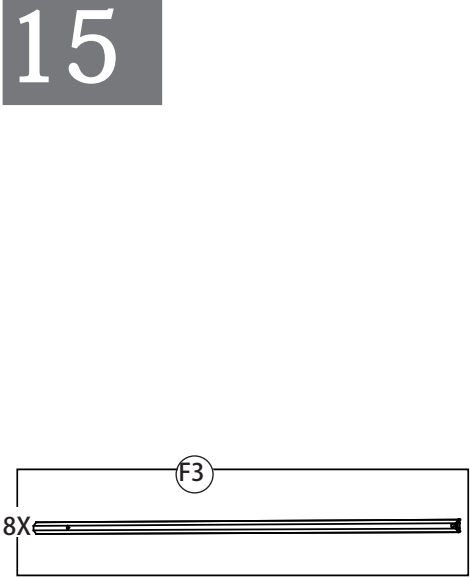

Do not lock the screws /  
Ne pas verrouiller les vis.

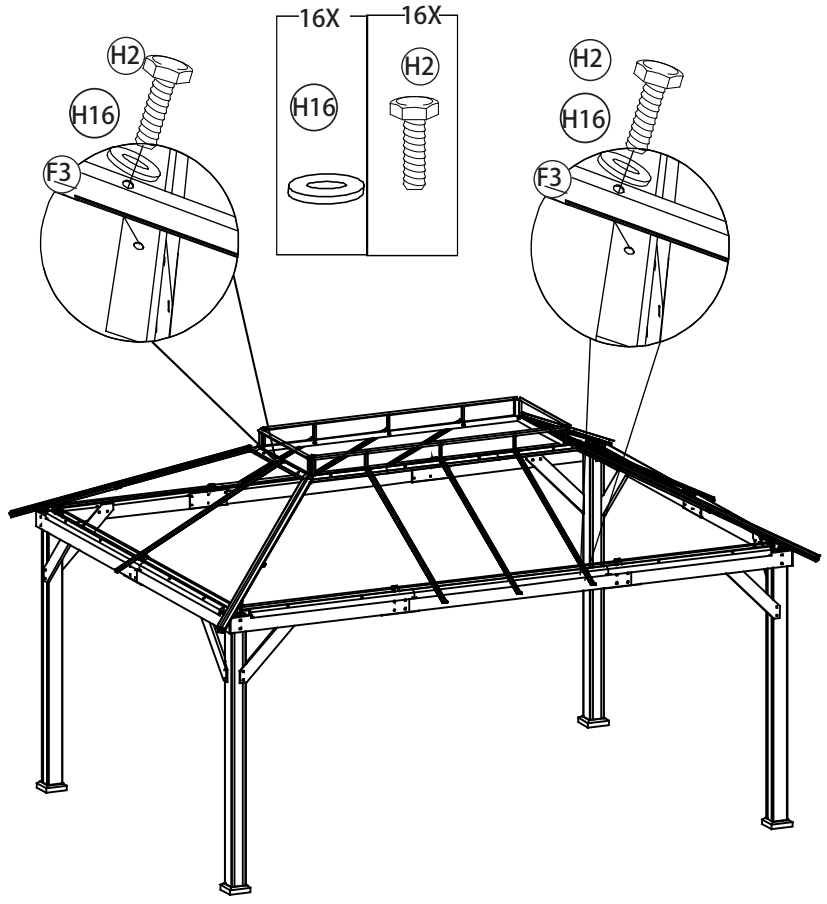

# 16

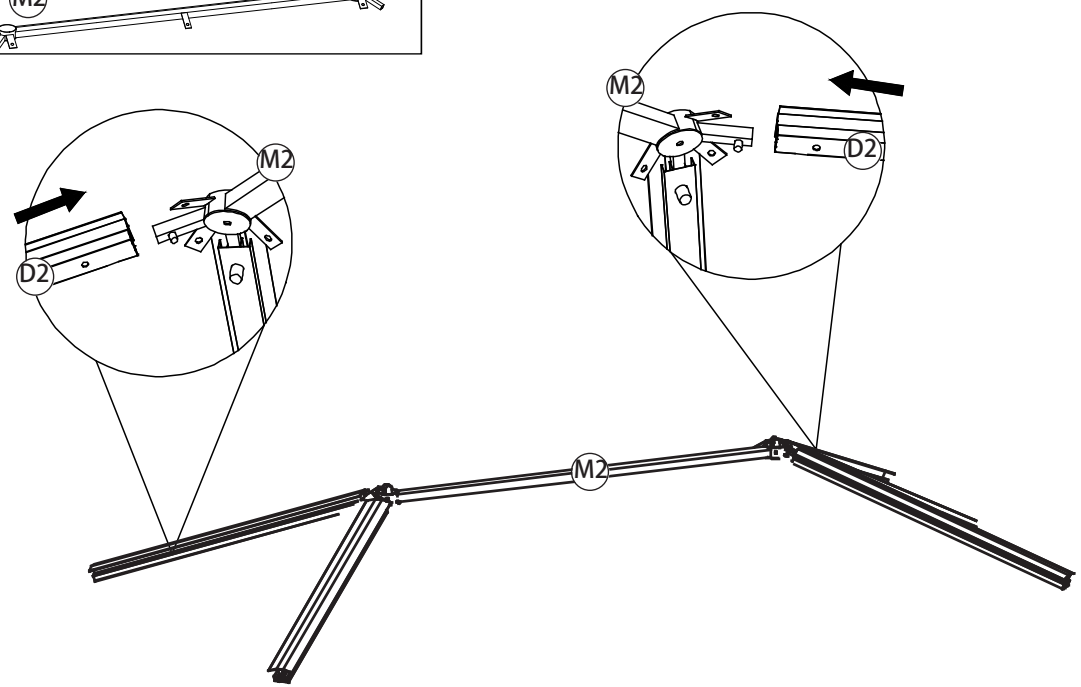
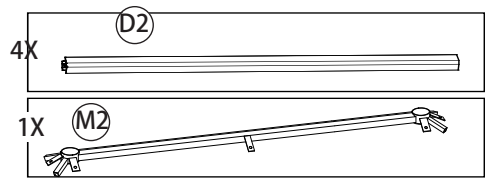

# 17

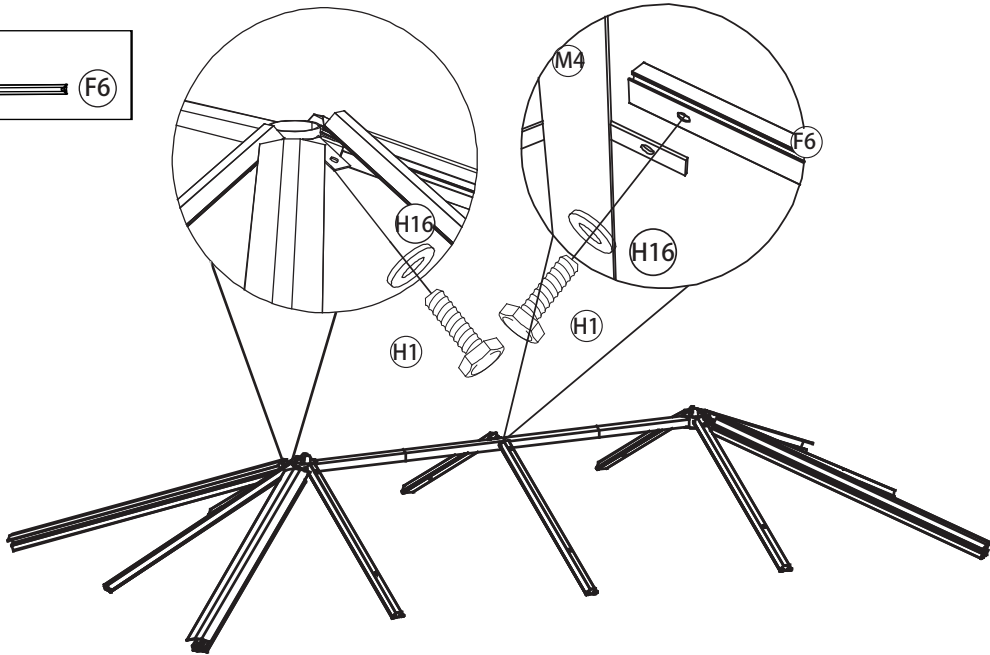
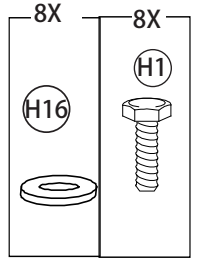
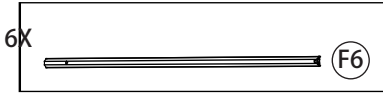

# 18

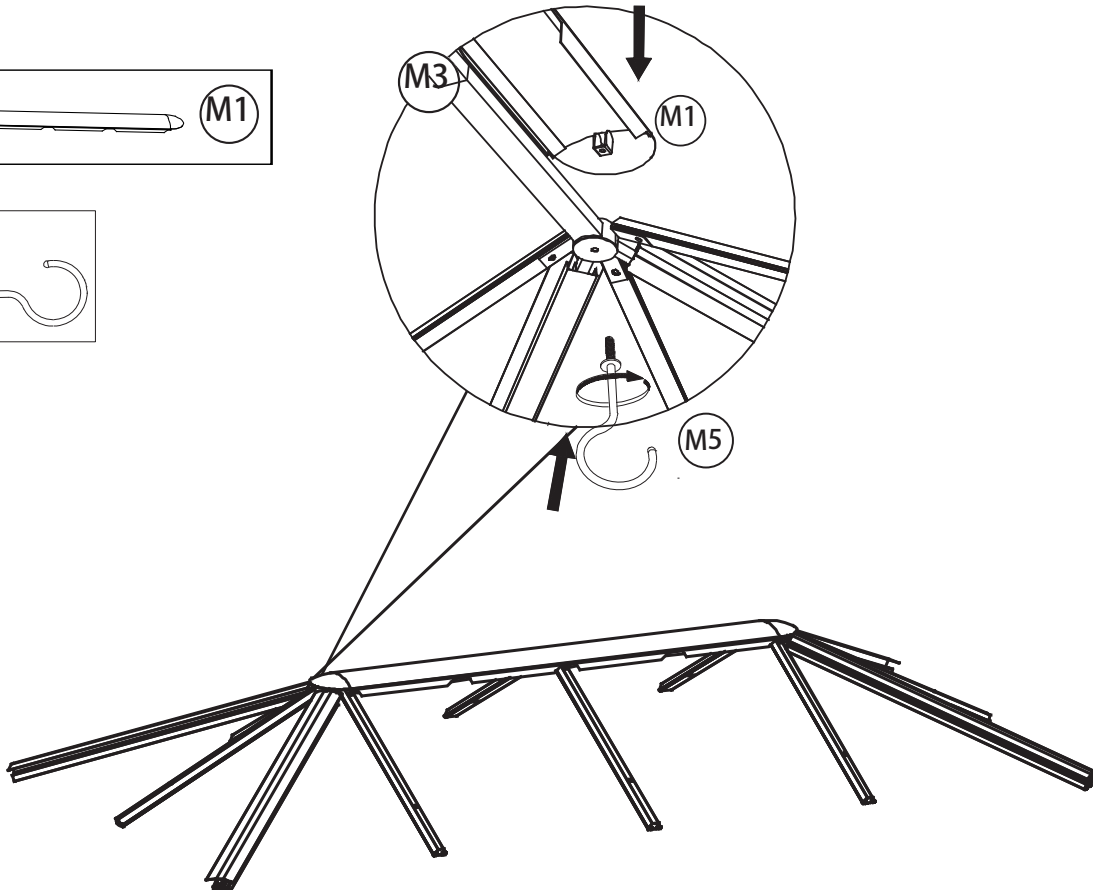
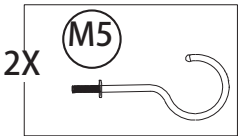
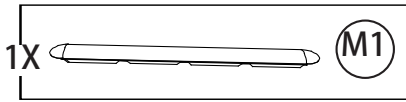

# 19

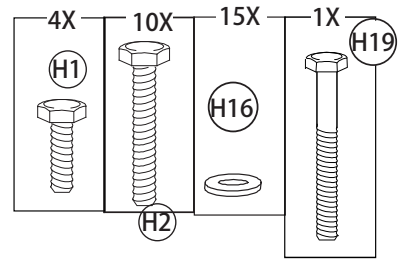
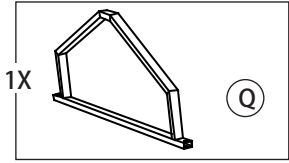

Do not lock the screws /  
Ne pas verrouiller les vis.

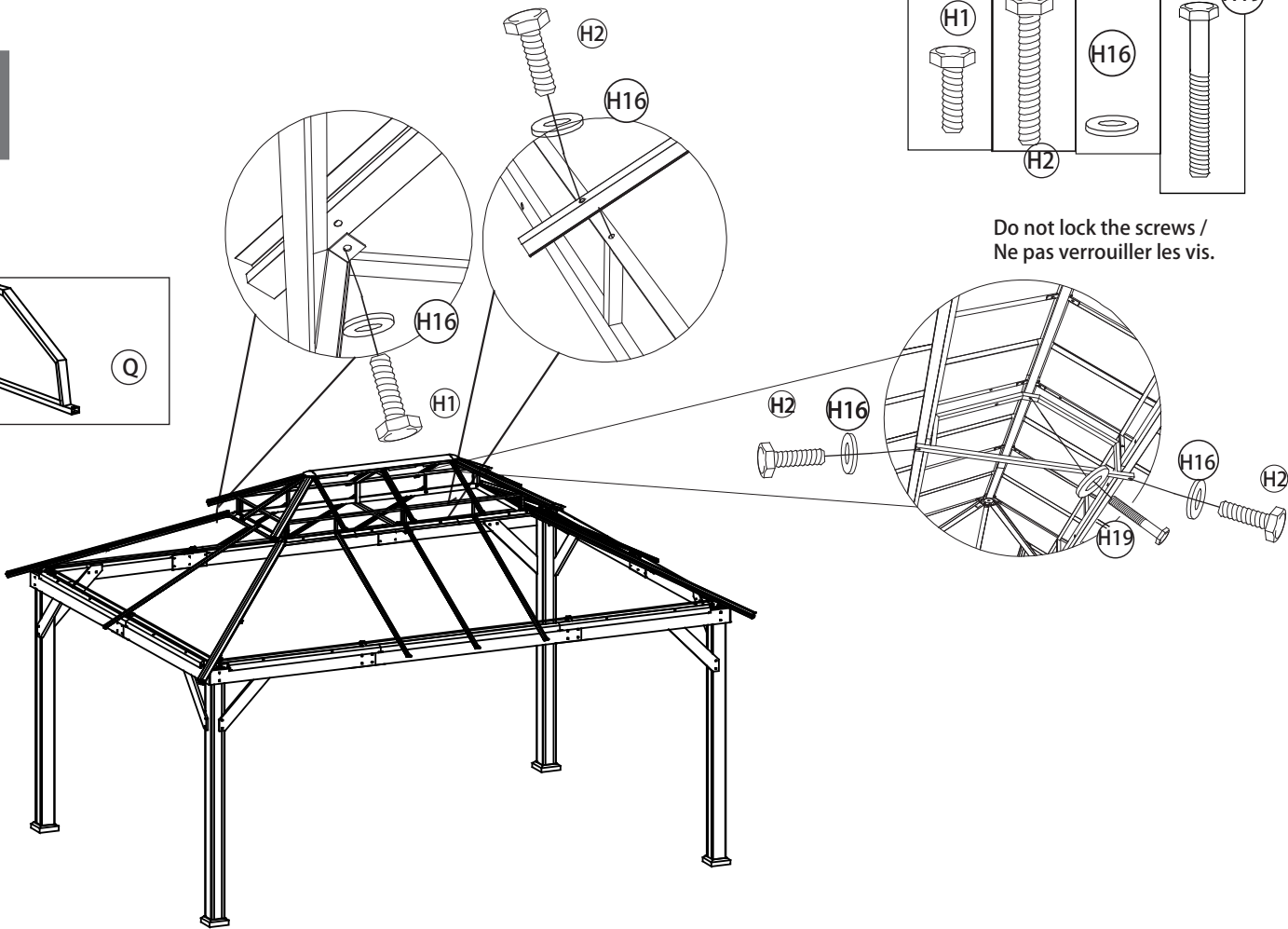

# 20

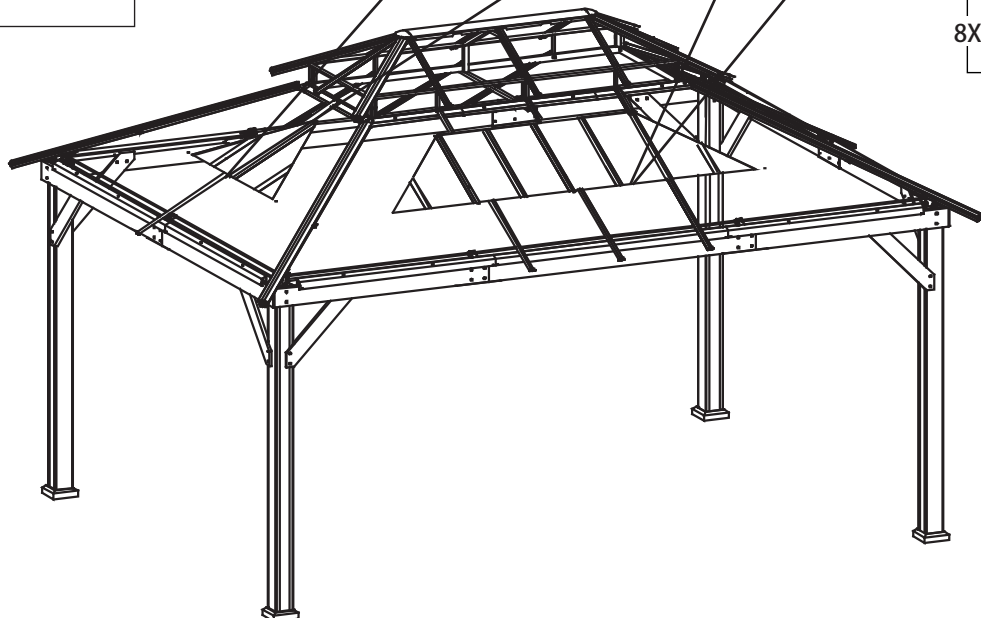
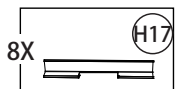
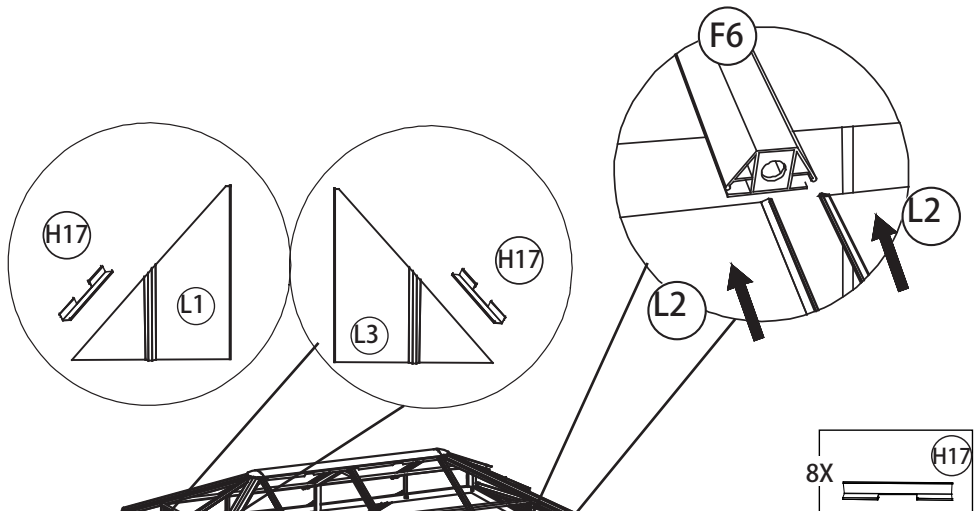
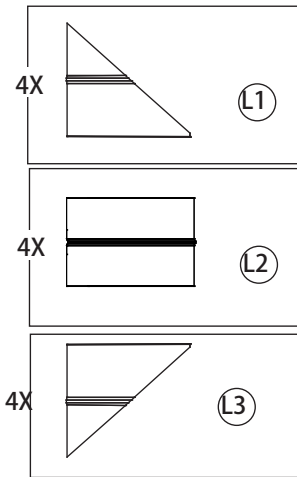

# 21

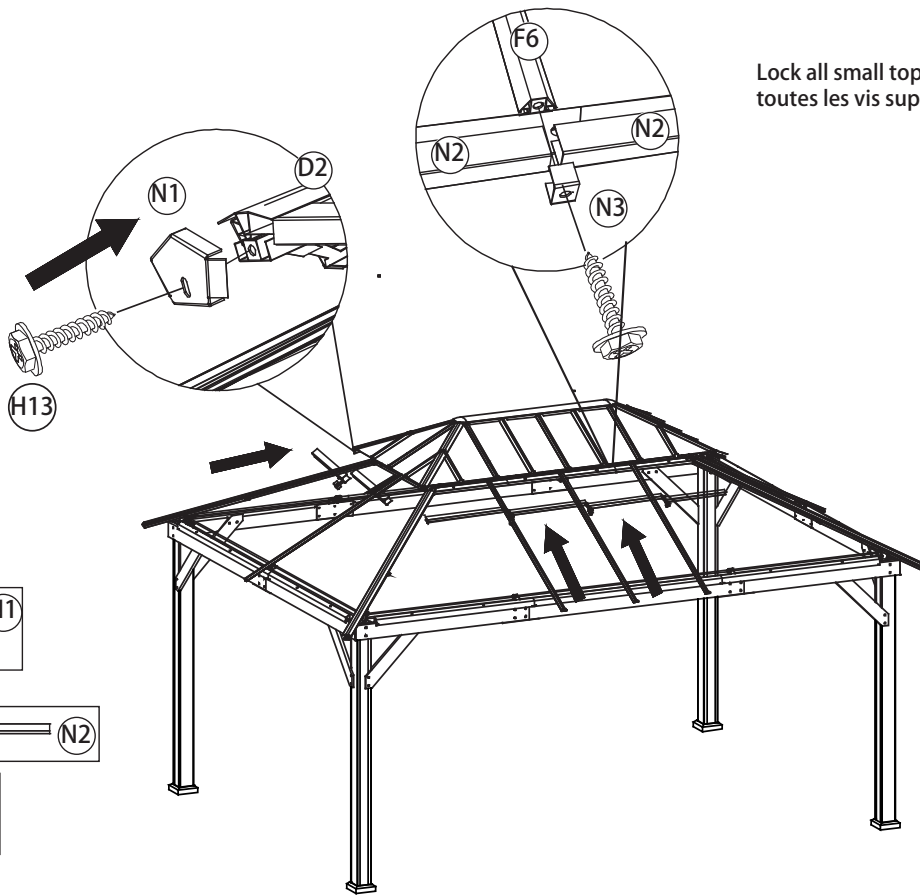

Lock all small top screws/Verrouiller toutes les vis sup é rieures

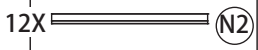
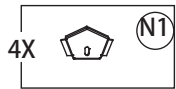
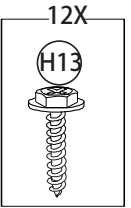

# 22

Do not lock the screws / Ne pas verrouiller les vis.

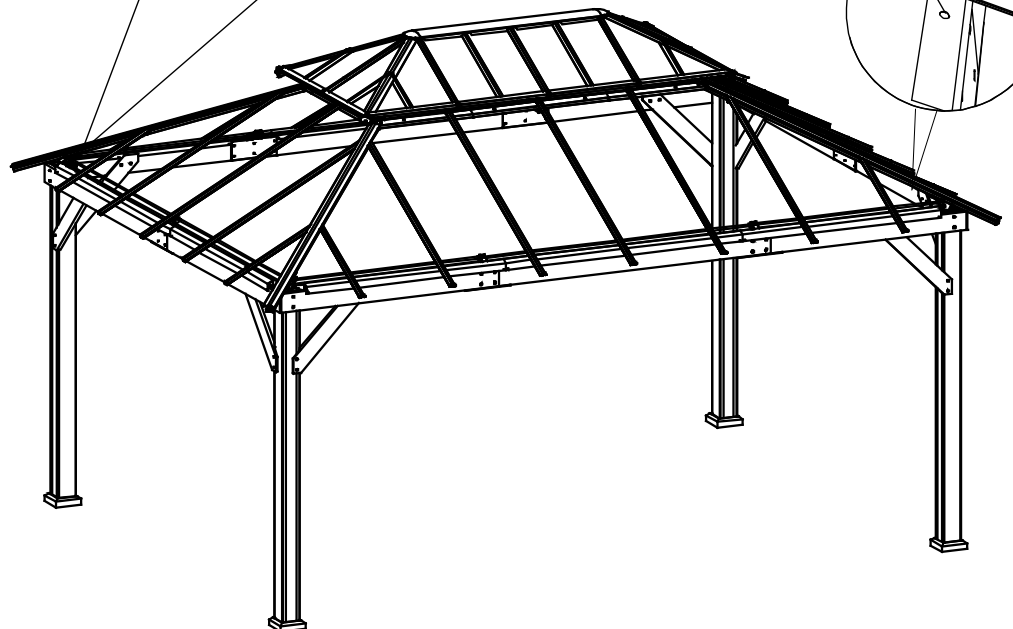
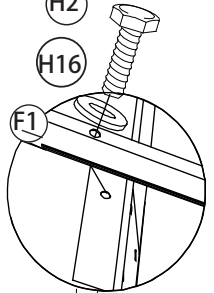
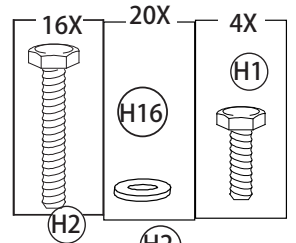
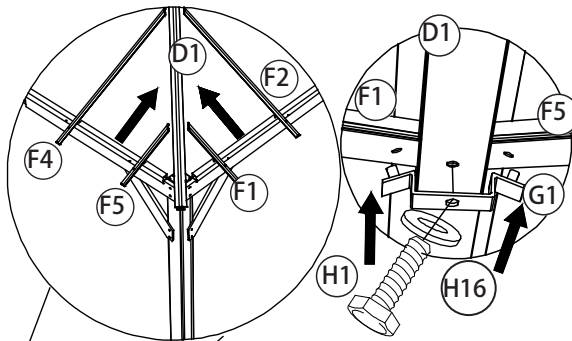
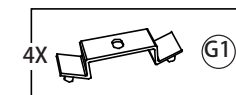
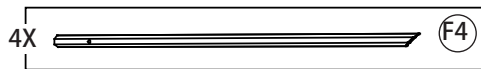
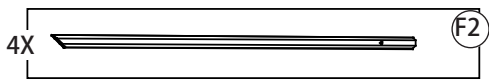

# 23

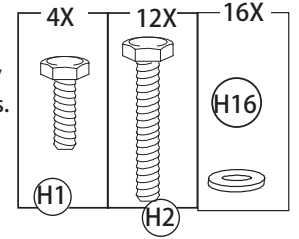
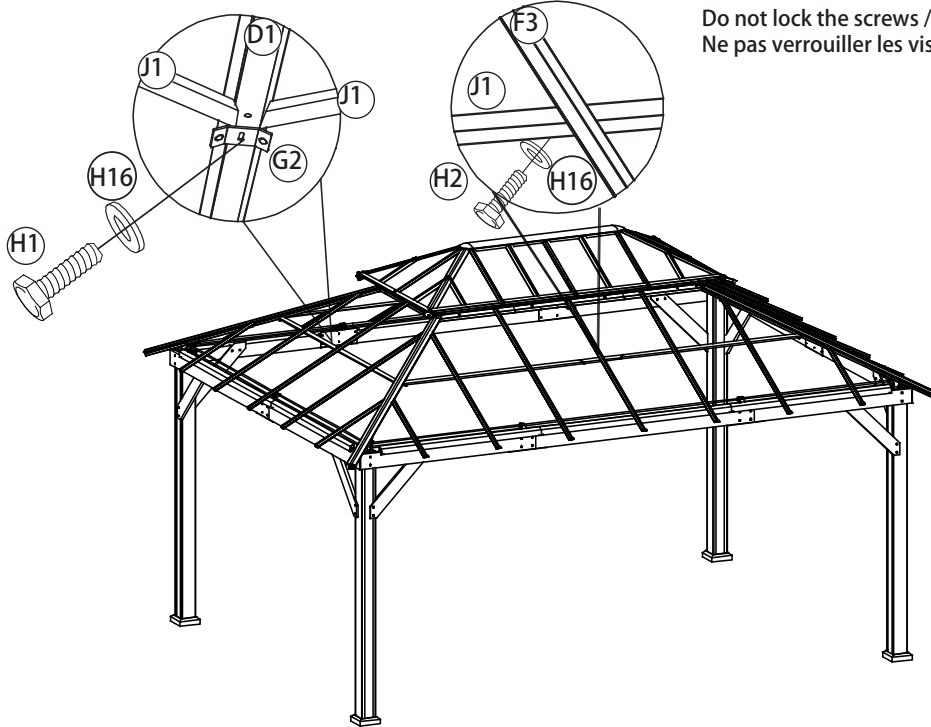
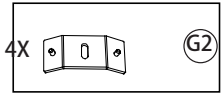
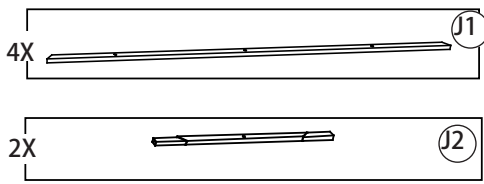

# 24

Do not lock the screws /  
Ne pas verrouiller les vis.

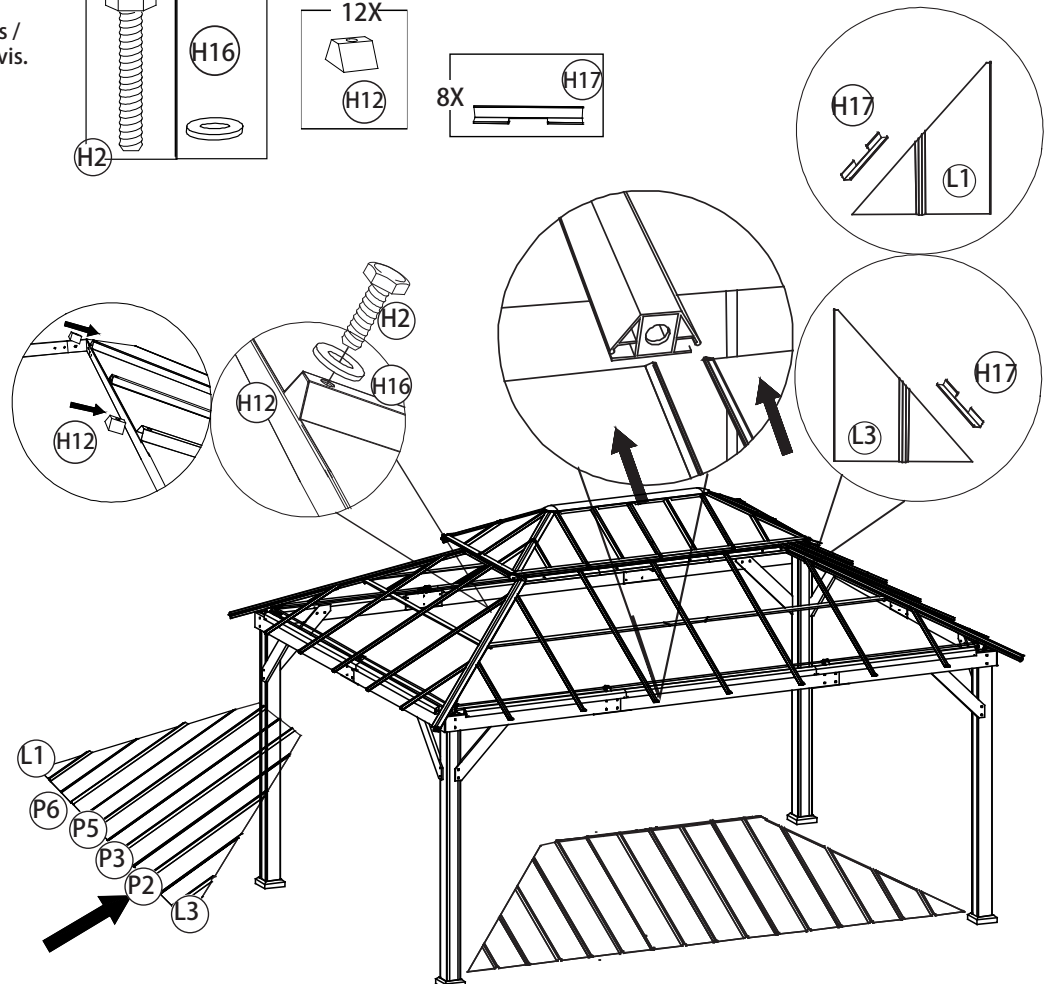
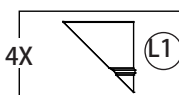
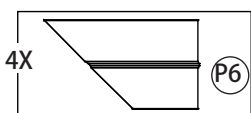
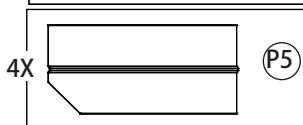
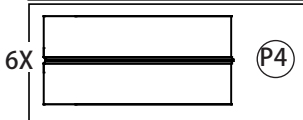
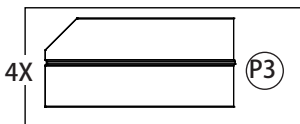
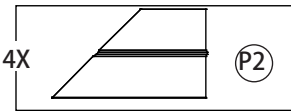
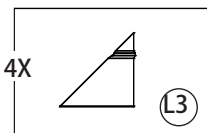
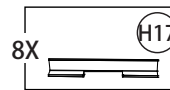
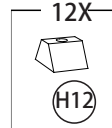
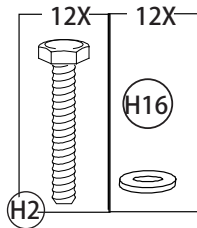

# 25

Lock all screws./Verrouiller toutes les vis.

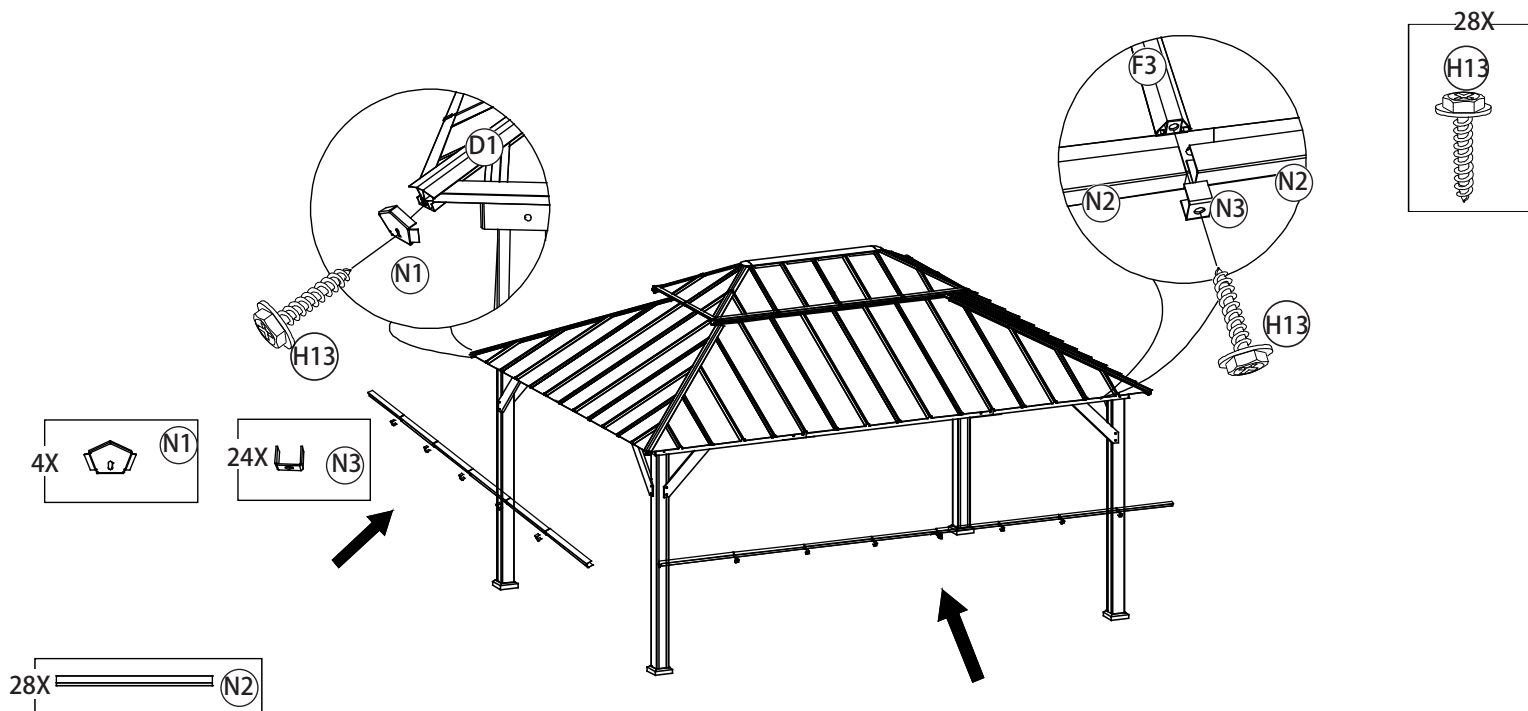

# 26

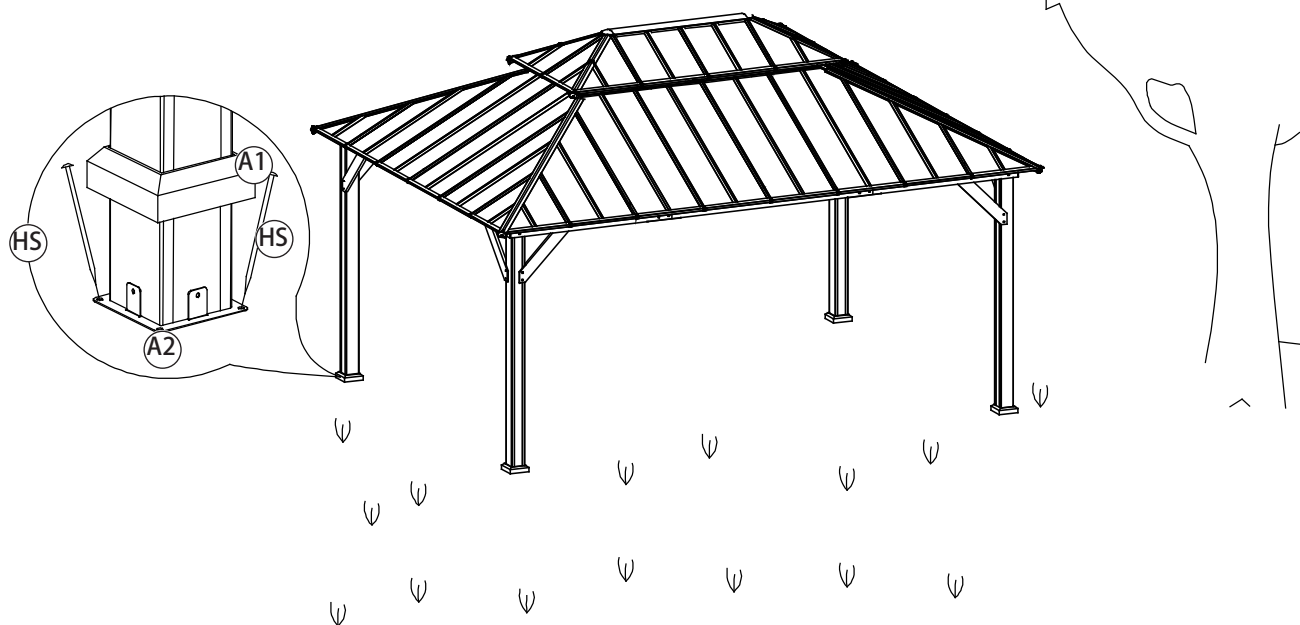
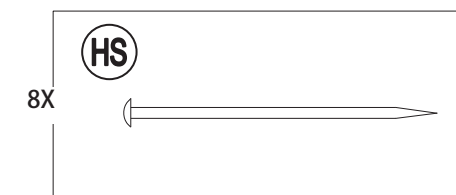

# WOOD CARE GUIDELINES

Wood requires some care and attention over its lifetime to ensure a long-lasting beautiful finish. Proper cleaning and maintenance will keep your wood products looking beautiful for a long time. Please follow these guidelines to maintain your wood surfaces.

- **Fading and weathering:** Wood is a natural product and is expected to change over time. Long periods of sun exposure can naturally lead to color fading. Weather extremes, temperature fluctuations, and humidity highs/lows cause wood to expand and contract, possibly leading to warping and cracking. Knots and small surface cracks are naturally occurring and do not affect the strength of the product.
- **Keeping dry:** Prolonged moisture and high or low humidity can be harmful for wood. Cracking or splitting from extremes outside of the normal humidity range of 35-65% are not covered by our warranty. Preventing prolonged exposure to moisture is advisable.
- **Cleaning:** Frequent light cleaning is recommended. Dust regularly using a slightly damp soft cloth, and then wipe dry (following the direction of the wood grain). For more thorough cleaning, use a soft cloth and a gentle soap solution (dilute ¼ cup mild dishwashing liquid soap with 1 gallon of warm water). Rinse with water, and then immediately dry the surfaces using a soft cloth. Do not use bleach, acid, or other solvents on any metal parts or surfaces. Minor stains or scratches can be lightly buffed with No.0000 steel wool, followed by an application of good quality wood-care oil, wiping in the direction of the grain.
- **Annual sealing:** It is advisable to annually maintain the wooden parts with a sealant or outdoor wax/oil to protect and enhance the wood surfaces. Twice yearly, after cleaning, apply a good quality wood-care oil or water-based sealant to the surfaces. Recommended options are outdoor water-based sealant, linseed, teak, or tung oil. Refer to the manufacturer's specific instructions for application. It is best to try on a small section of wood, then if satisfied with the result, continue the application, taking care to avoid any metal surfaces.
- For further questions and concerns, please contact: [customer.care@sunjoygroup.com](mailto:customer.care@sunjoygroup.com)

# RECOMMANDATIONS POUR SOIN DU BOIS

Le bois exige un peu de soin et d'attention pendant sa vie pour assurer une belle finition durable. Le nettoyage et l'entretien convenables maintiendront la beauté de vos produits en bois plus longtemps. Veuillez suivre ces conseils pour préserver vos surfaces en bois.

- **Décoloration et érosion:** le bois est un produit naturel qui est prévu de changer avec le passage du temps. De longues périodes d'exposition au soleil peuvent naturellement conduire à la décoloration des couleurs. Les extrêmes météorologiques, les fluctuations de la température et les hauts / bas d'humidité provoquent l'expansion et la contraction du bois, ce qui peut entraîner à la déformation et aux fissures. Les noeuds et les petites fissures de surface sont naturelles et n'affectent pas la solidité du produit.
- **Garder au sec:** l'humidité prolongée et l'humidité élevée ou basse peuvent être défavorables pour le bois. La fissuration ou les fentes causées par les intempéries en dehors de la gamme d'humidité normale de 35 à 65% ne sont pas couvertes par notre garantie. Il est recommandé d'empêcher l'exposition prolongée à l'humidité.
- **Nettoyage:** un léger nettoyage fréquent est recommandé. Époussetez régulièrement avec un chiffon doux légèrement humide, et puis séchez (en suivant la direction du grain de bois). Pour un nettoyage plus profond, utilisez un chiffon doux et une solution de légère de savon à vaisselle (diluer ¼ tasse de savon lave-vaisselle doux dans 1 gallon d'eau tiède). Rincez avec de l'eau, puis séchez immédiatement les surfaces à l'aide d'un chiffon doux. N'utilisez pas de javelle, d'acide ou d'autres solvants sur aucune des pièces ou des surfaces métalliques. Les petites taches ou les rayures peuvent être légèrement polies avec de la palle de fer n ° 0000, suivie d'une application d'huile de soins pour bois de bonne qualité, étendue dans le sens du grain.
- **Enduit annuel:** Il est conseillé d'entretenir chaque année les pièces en bois avec un enduit scellant ou une cire ou huile extérieure pour protéger et améliorer les surfaces en bois. Deux fois par an, après le nettoyage, appliquez sur les surfaces une huile de soins de bois de bonne qualité ou un enduit scellant à base d'eau. Les options recommandées sont le scellant extérieur à base d'eau, les graines de lin, le teck ou l'huile d'abrasin. Consultez les instructions spécifiques du fabricant pour l'application. Il est préférable d'essayer une petite section de bois, et si vous êtes satisfait du résultat, continuez l'application, en prenant soin d'éviter les surfaces métalliques.
- For further questions and concerns, please contact: [customer.care@sunjoygroup.com](mailto:customer.care@sunjoygroup.com)

# WOOD CARE GUIDELINES

## Frequently Asked Questions

**Q1. What kind of wood is this made from?**

It is China-Fir (Cunninghamia/Cedar) wood.

**Q2. Is the wood waterproof?**

No, it is not waterproof, however it is water-resistant. It is able to resist the penetration of water to some degree but not entirely. Do not assemble the gazebo onto soil/sandy earth since water might puddle or pool around the gazebo posts, and stakes do not have enough anchorage in these types of soil.

**Q3. Before assembly, can I stain the wood parts with a different color stain?**

To change the color requires professional procedures, involving spraying equipment and waterbased stain only. This operation is not recommended.

**Q4. What should we apply to the wood to keep it looking good and maintained? Do I need to treat the wood to make it weather resistant?**

Yes, a cleaning and sealing regimen is advised. Please check our “wood care guidelines” for details.

**Q5. Is there any way to seal the crack to prevent further damage? Does it affect the strength of the product?**

Knots and small checks (cracks) are naturally occurring and do not affect the strength of the product. It is advisable to annually maintain the wooden parts of the gazebo with a coat of water-base water repellent sealant or outdoor wax oil to protect & enhance the beauty of wood, if you are concerned that a part has experienced a severe weathering problem please contact our customer service department for further assistance.

**Q6. How do I remove mold from cedar wood?**

First thoroughly clean the wooden parts, following our “wood care guidelines” cleaning regimen. Then clean with a chlorine-free “oxygen” bleach cleaner, following the product’s instructions. Then clean with an oxalic acid wood/deck cleaner, following the product’s instructions. If necessary, re-stain the wood with water-based stain. Please maintain the wood parts regularly and keep them dry.

# RECOMMANDATIONS SUR LES SOINS DU BOIS

## Questions Fréquentes

**Q1. De quelle sorte de bois est-ce fait?**

C'est du Bois de Sapin Chinois (Cunninghamia/Cèdre).

**Q2. Le bois est-il imperméable?**

Non, il n'est pas imperméable, cependant il est résistant à l'eau. Il est apte à résister à la pénétration de l'eau à un certain degré, mais pas complètement. N'assemblez pas le gazébo sur un terrain de terre ou de sable car il peut se former des flaques d'eau ou l'eau peut s'accumuler autour des poteaux, et les piquets n'auront pas assez d'ancrage sur ces sortes de terrains.

**Q3. Avant d'installer, pouvons-nous teindre les pièces en bois d'une couleur de teinture différente?**

Pour changer la couleur, il faut des procédures professionnelles, impliquant uniquement des équipements de pulvérisation et des teintures à base d'eau. Cette opération n'est pas recommandée.

**Q4. Que devons-nous appliquer sur le bois pour garder sa bonne apparence et entretien ? Devons nous traiter le bois pour le rendre résistant aux intempéries?**

Oui, un régime de nettoyage et d'étanchéité est conseillé. Veuillez consulter nos «recommandations sur les soins du bois» pour plus de renseignements.

**Q5. Existe-t-il un moyen de sceller une fissure pour éviter plus de dommages? Est-ce que cela affecte la résistance du produit?**

Les noeuds et les petites marques (fissures) sont naturels et n'affectent pas la solidité du produit. Il est conseillé d'entretenir annuellement les parties en bois du gazébo avec une couche d'enduit à base d'eau ou de la cire extérieure pour protéger et améliorer la beauté du bois, si vous craignez qu'une pièce ait souffert un grave problème d'altération, veuillez contacter Notre service au client pour plus d'aide.

**Q6. Comment enlever la moisissure du bois de cèdre?**

Nettoyez d'abord les pièces en bois, en suivant notre régime de nettoyage dans les «recommandations de soins du bois». Ensuite, nettoyez avec un nettoyant une javelle sans chlore, ¼ oxygénée », en suivant les instructions du produit. Ensuite, nettoyez avec un nettoyant d'acide oxalique pour bois ou terrasse, en suivant les instructions du produit. Si nécessaire, refinissez le bois avec une teinture à base d'eau. Veuillez entretenir les pièces en bois régulièrement et les garder au sec.

## Maintenance

- Steel components for this gazebo are treated with rust inhibiting paint . However, due to the nature of steel, surface oxidation (rusting) will occur if these protective coatings are scratched. This is not a defect and thus not covered by the warranty.
- To minimize this condition, it is recommended to use care when assembling and handling the product to prevent scratching the paint. Should any scratching or damage occur, it is recommended to cover the scratch immediately with rust inhibiting resistant paint (not included).
- Surface rust can also be easily removed with a very light application of regular cooking oil or WD-40. If surface oxidation (rusting) occurs and if no measure is taken to prevent this, the oxidation may start dripping onto deck or patio and caused damaging stains, which may be difficult to remove. This can be prevented if the above-mentioned measures are taken to keep the product from oxidizing.
- An annual application of a water-based stain or sealant is recommended to reduce weathering and extend the life of your gazebo.
- Periodically check and ensure that all bolts are well-tighten during use.
- Inspect all wood parts regularly for damage or deterioration. Remove/sand splinters and replace any wood parts that are showing signs of structural damage. Note that knots, small cracks and weathering are natural in an outdoor wood product and do not negatively affect the structural integrity of the gazebo.
- Keep instruction manual for future reference.
- Keep the original packaging to store the gazebo.

## Limited Manufacturer's Warranty

Sunjoy Group warrants to the original purchaser that this item is free from defects in workmanship and materials for a period of 1 year from the date of purchase, provided the item was factory-sealed at the time of purchase and is maintained with care and used only for personal, residential purposes. Should any manufacturing defect arise within this warranty period, Sunjoy Group will replace (at our option) any defective merchandise or parts upon proof of purchase; however, transportation and delivery costs, as well as payments to a third party for assembly or disassembly of the item, remain the responsibility of the purchaser. A purchaser of an "open box," previously-returned, or "clearance" item, as well as original purchasers outside of the warranty period, may obtain replacement parts from Sunjoy Group for products in current production, at nominal cost.

## Exclusions

Items used for commercial, contract, or other non-residential purposes, or items damaged due to acts of nature, vandalism, misuse, or improper assembly are not covered. Corrosion or rusting of hardware is not covered.

Proof of purchase (dated register receipt) is required for warranty claims. Warranty is to the original purchaser and is non-transferable. Any replacement of warranted items will be in the original style and color, or a similar style and color if the original is unavailable or has been discontinued. As some states do not allow exclusions or limitations on an implied warranty, the above exclusions and limitations may not apply. This warranty gives you specific rights, and you may also have other rights, which vary from state to state.

## Care and Maintenance

- Les composants en acier de ce belvédère sont traités avec une peinture antirouille. Toutefois, en raison de la nature de l'acier, une oxydation de la surface (rouille) se produira si ces revêtements protecteurs sont égratignés. La garantie ne couvre pas ce phénomène puisqu'il ne s'agit pas d'un défaut.
- Afin de minimiser cette situation, nous recommandons d'être prudent lors de l'assemblage et de la manipulation du produit afin d'éviter d'égratigner la peinture. En cas d'égratignure ou de dommage, nous recommandons d'effectuer immédiatement une retouche avec une peinture antirouille.
- La rouille de surface peut facilement être retirée à l'aide d'une petite quantité d'huile de cuisson ordinaire ou de WD-40. Si une oxydation (rouille) de la surface se produit et qu'aucune mesure n'est prise pour corriger la situation, la rouille pourrait couler sur la terrasse et causer des taches dommageables qui peuvent être difficiles à enlever. Cela peut être évité si les mesures mentionnées ci-dessus sont prises pour empêcher l'oxydation du produit.
- Une application annuelle d'une teinture ou d'un scellant à base d'eau est recommandée pour résister aux intempéries et prolonger la durée de vie de la tonnelle.
- Vérifiez périodiquement pour vous assurer que tous les écrous sont bien serrés pendant l'utilisation.
- Inspectez régulièrement toutes les pièces en bois pour détecter tout dommage ou détérioration. Enlevez/ poncez les éclats et remplacez toutes les pièces en bois qui montrent des signes de dommages structurels. Notez que les noeuds, toutes les fissures et les intempéries sont naturels dans un produit en bois extérieur et n'affectent pas négativement l'intégrité structurelle de la tonnelle.
- Conservez le manuel d'instructions pour référence future.
- Conservez l'emballage d'origine pour ranger la tonnelle.

## Garantie limitée du fabricant

Sunjoy Group garantit à l'acheteur initial que ce produit ne présentera aucun défaut de fabrication et de matériaux pendant une période de un an à compter de la date de l'achat si le produit a été acheté dans son emballage scellé à l'usine, et s'il a été entretenu correctement et utilisé à des fins personnelles et résidentielles seulement. Si le produit présente un défaut de fabrication pendant cette période de garantie, Sunjoy Group remplacera (à sa discrétion) toute marchandise ou pièce défectueuse sur présentation d'une preuve d'achat. Toutefois, les frais de transport et de manutention, ainsi que les paiements versés à un tiers pour l'assemblage ou le démontage du produit, demeurent la responsabilité de l'acheteur. Les acheteurs de produits avec « boîte ouverte », précédemment retournés ou « en liquidation », ainsi que les acheteurs initiaux de produits dont la période de garantie est terminée, peuvent obtenir des pièces de rechange auprès de Sunjoy Group pour des produits actuellement en production, à peu de frais.

## Exclusions:

les articles utilisés à des fins commerciales, locatives ou non résidentielles et les articles endommagés par des phénomènes naturels, des actes de vandalisme, un usage inapproprié ou un assemblage inadéquat ne sont pas couverts. La corrosion et la rouille de la quincaillerie ne sont pas couvertes. Une preuve d'achat (une copie de votre reçu daté) doit être présentée avec toute réclamation au titre de la garantie. La garantie n'est accordée qu'à l'acheteur initial et est non transférable. Si l'article original n'est plus offert, il sera remplacé par un article d'une couleur et d'un style similaires. Certains États ou certaines provinces ne permettent pas l'exclusion ou la limitation d'une garantie implicite, de sorte que les limitations et exclusions mentionnées ci-dessus peuvent ne pas s'appliquer à vous. Cette garantie vous confère des droits précis. Il est possible que vous disposiez également d'autres droits, qui varient d'un État ou d'une province à l'autre.