

ASSEMBLY, MAINTENANCE, & **USER MANUAL**

48" MINI TRAMPOLINE

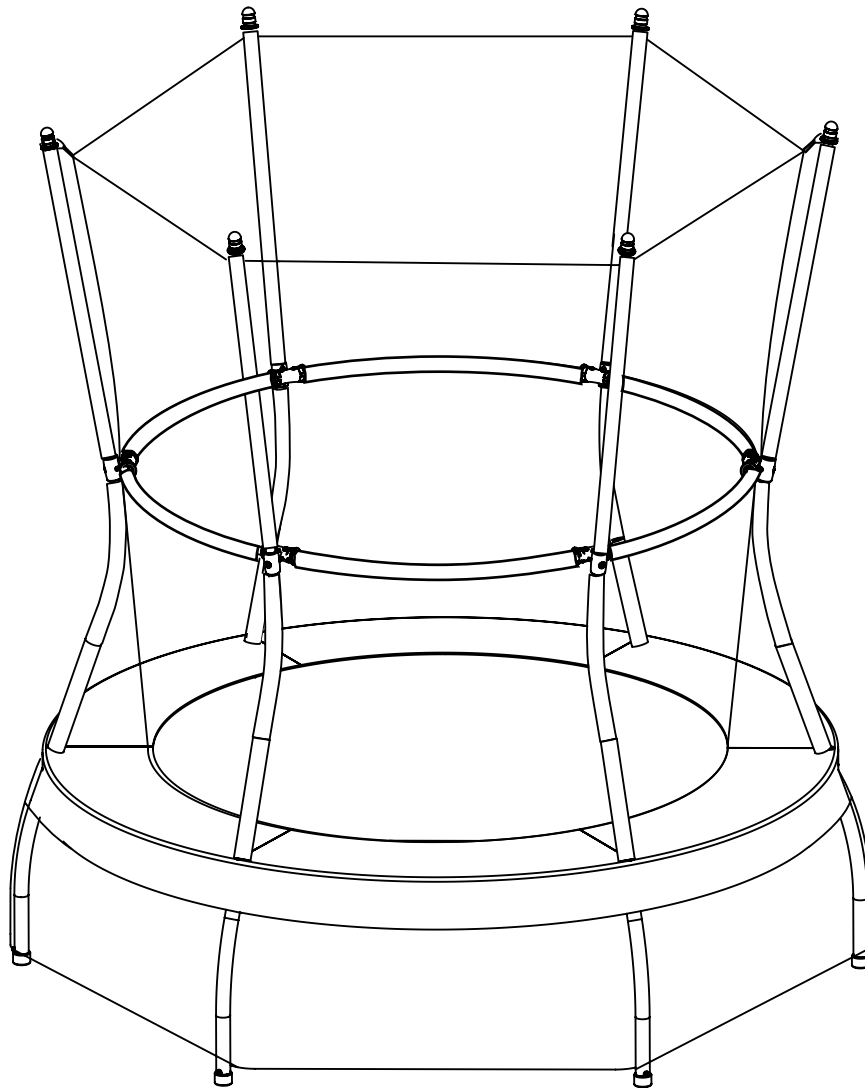

WARNING

Read all precautions and instructions in this manual before using this equipment. Save this manual for future reference.
Maximum user weight 100 lbs.

SKYWALKER

TRAMPOLINES

Skywalker Holdings LLC
P.O. Box 574, Brigham City, UT 84302

TABLE OF CONTENTS

Part List.....	3
Part Identification.....	4-5
Exploded Drawing.....	6
Assembly.....	7-16
Maintenance and Care Information.....	17
Warning Label Placement.....	17
Instructions for Use.....	18
Methods of Accident Prevention.....	19
Instructions and Model Lessons.....	20-21
Trampoline Safety Information.....	22
Enclosure Safety Information.....	23
Limited Warranty.....	24



STOP EVERYTHING YOU'RE DOING AND REGISTER YOUR MINI BOUNCER

Find our warranty registration online by typing in: www.skywalkertrampolines.com/registration/

You'll need to have the following information handy:

- Name
- Address
- Phone number
- Date of purchase
- Email address
- Trampoline model number
- Trampoline serial number
- Retailer the trampoline was purchased from

This manual applies to the following model numbers: APB48SF10, SWB48UB00 and SBT48.4.

HEY WE'VE GOT SOMETHING REALLY IMPORTANT TO SAY

Check us out online! We've got **assembly videos** (for those of you who prefer movies over books), **FAQs** (so you know you're not the only one who needs help), fascinating **blog posts** (did you know jumping burns more calories than running?), and most importantly, find us on social media! Because we want to be your friend. **We'd love to see how you are using our products!**

Website: skywalkertrampolines.com
Facebook: facebook.com/skywalkertrampolines
YouTube: youtube.com/c/SkywalkerTrampolines

Pinterest: pinterest.com/swtrampolines
Twitter: twitter.com/swtrampolines
Instagram: instagram.com/skywalker_trampolines



IMPORTANT

Trampolines and enclosures are susceptible to winds. Be sure to secure your trampoline and enclosure. Wind damage is not covered in the warranty of your trampoline.



WARNING

CHOKING HAZARD- Small parts not for children under 3 years.



WARNING

Adult assembly required.

PART LIST

Key No.	Qty.	Description
1	6	Frame Tube
2	6	Leg
3	6	Enclosure Tube
4	6	Rail
5	6	Joint
6	1	Mat with net
7	1	Pad with net
8	30	Elastic with ball
9	6	Upper foam 21.5 in (545 mm)
10	6	Middle foam 11.9 in (302 mm)
11	6	Lower foam 8 in (205 mm)
12	6	Rail foam 16.9 in (430 mm)
13	6	Sleeve
14	6	Pole cap
15	6	End cap
16	32	Screw
17	1	Screw Driver
#	1	User Manual
#	1	Warning Label

ORDERING REPLACEMENT PARTS

We get it, sometimes things happen, but the fun shouldn't stop just because you need a new bolt or screw. To order replacement parts, check out our website www.skywalkertrampolines.com or call our toll-free Customer Care Hotline at **1-866-603-Jump (5867)**, Monday - Thursday 8 a.m. to 5 p.m., Friday 8 a.m. to 3 p.m. (excluding holidays).

Our customer service team will ask you a few questions in order to get the replacement part sent out as soon as possible. We're not trying to complicate your life, we promise.

When calling, make sure to have the following information ready:

- The model # of the product (see the front cover of this manual)
- The key # and description of the part (see the part list above)
- The quantity needed (only you know the answer to that one!)

BEFORE YOU BEGIN

Thank you for choosing Skywalker Trampolines! We're just as excited as you are to help your family live an active (but most importantly **FUN**) lifestyle. This model is one of our favorites, and we're confident you'll love it, too. We want to make things easier for you, so we have listed all the important information that you (and your little outdoor adventurers) need to know. Make sure you brush up on the warnings, instructions, assembly, maintenance, and use of your new product because there will be a pop quiz at the end (Okay, not **REALLY**, but if you're still reading this, props to you! You're awesome!).

PART IDENTIFICATION

Before you begin, take a look at the drawings below to make sure you have all the parts! The numbers in the squares to the left (key numbers) will help you identify the parts during assembly.

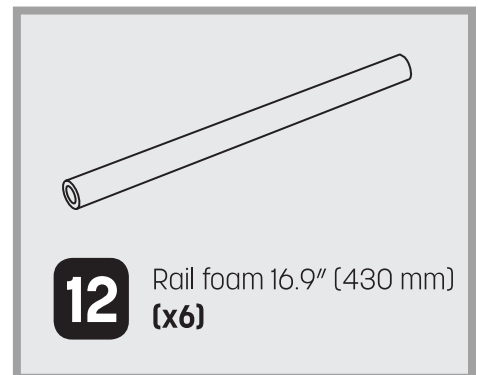
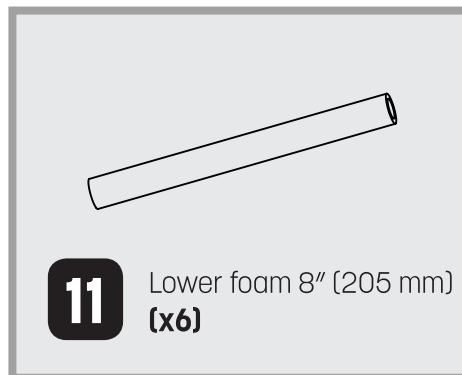
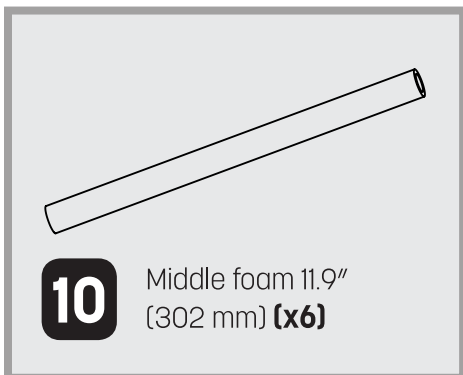
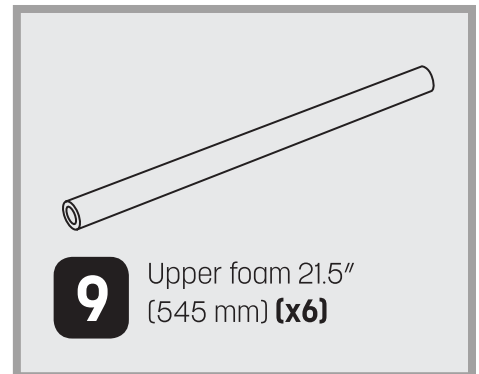
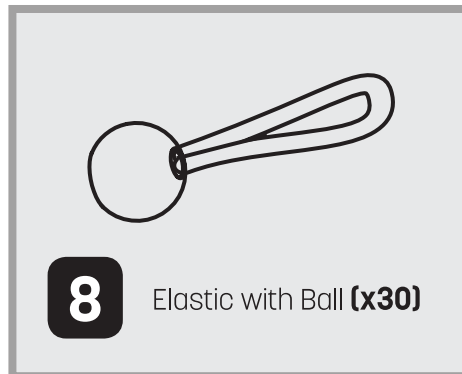
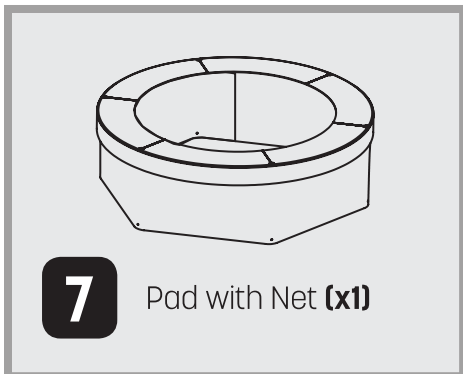
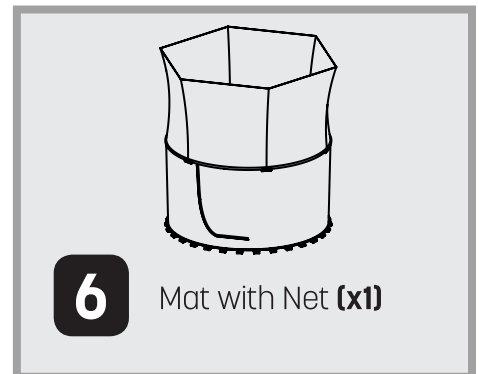
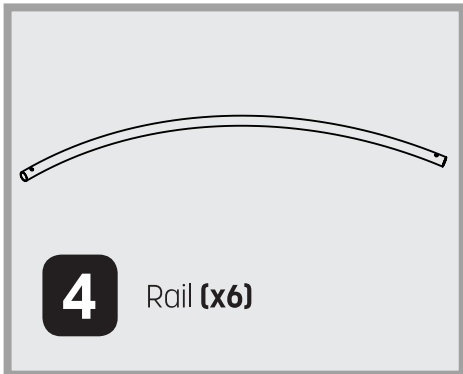
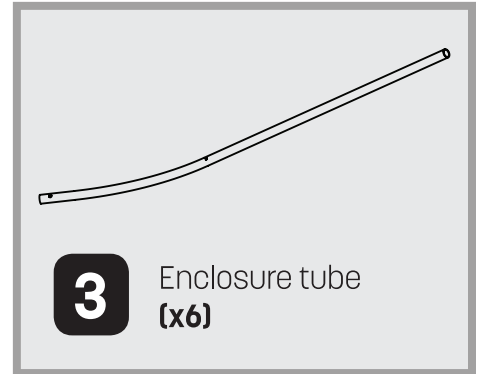
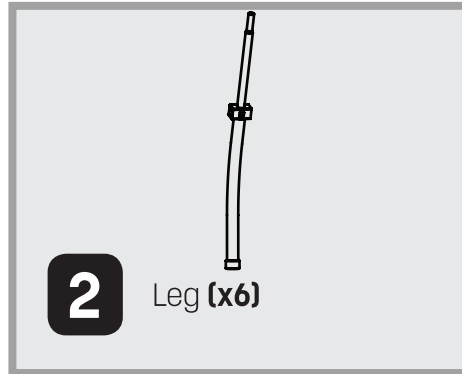
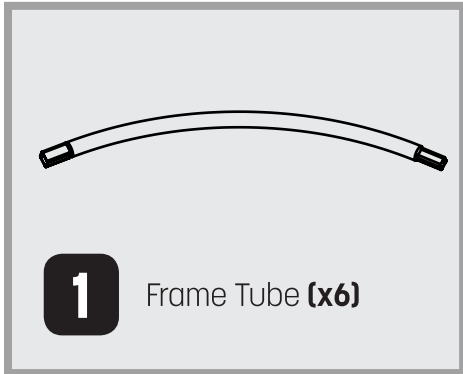

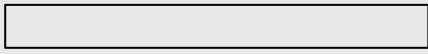

13 Sleeve (x6)

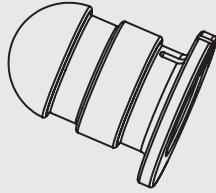

14 Pole Cap (x6)

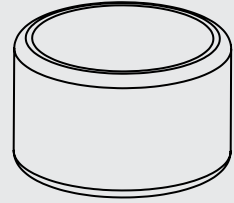

15 End cap (x6)
(Pre-installed)

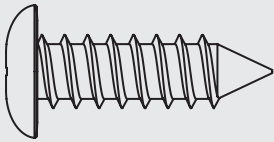

16 Self-tapping Screw
(x32) two spare parts

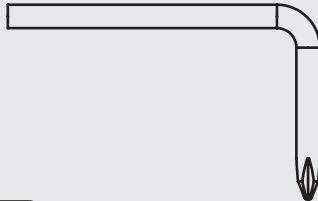

17 Screw Driver (x1)

EXPLODED DRAWING

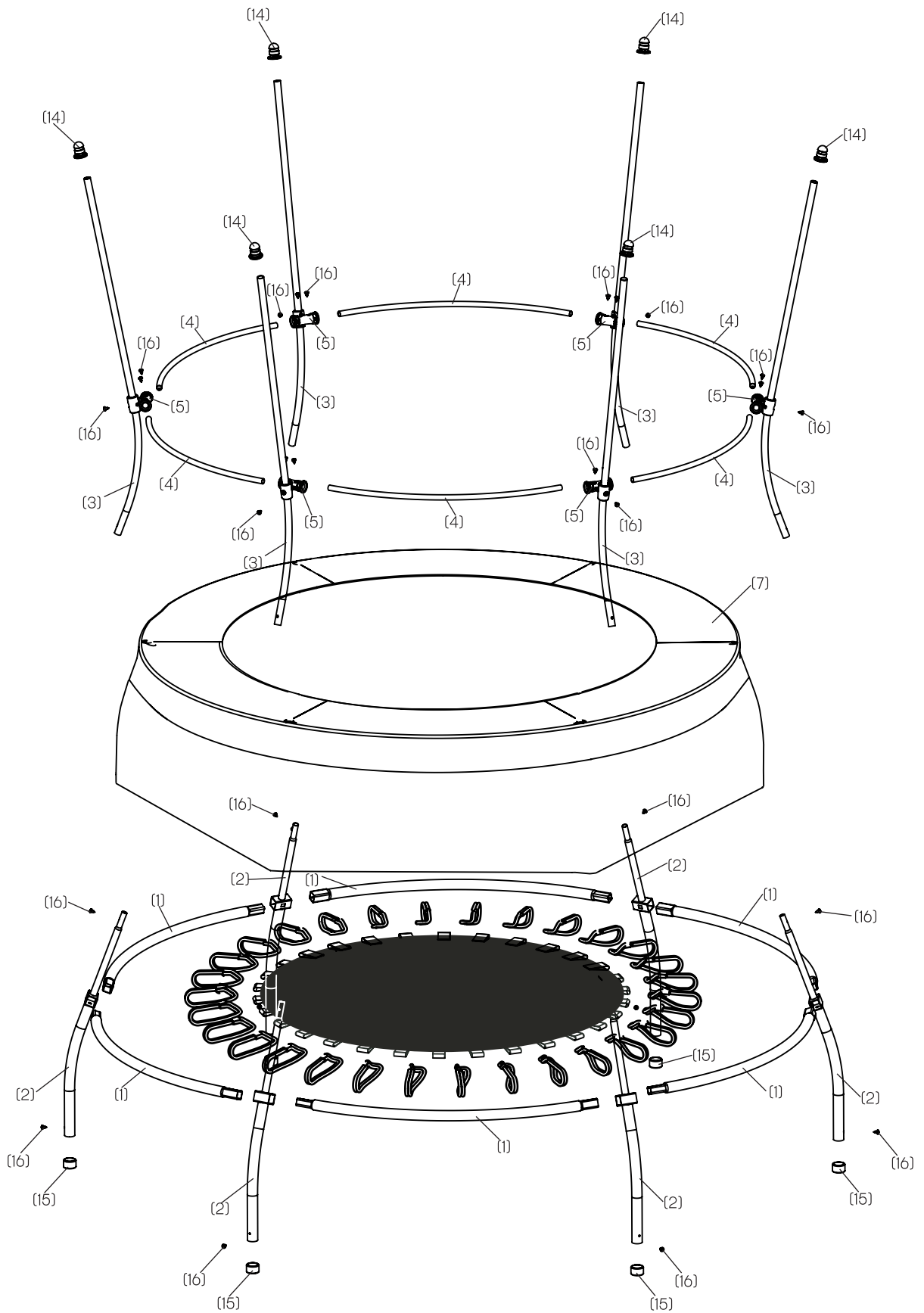

ASSEMBLY

READ THIS BEFORE YOU BEGIN

- You'll probably need at least **two adults** and **2 hours** to assemble your trampoline (of course, that depends on what model you have, and whether or not you're secretly a superhero)
- We've provided some tools to help with assembly, but you're more than welcome to use your own. There will also be a part in the assembly process where gloves will come in handy.
- The assembly steps refer to parts by their descriptions and key numbers (see the part list on page 3)
- The assembly steps are written in a specific order, and if you don't follow them exactly, you may end up having to start all over again
- Most importantly, this may not be the easiest thing you've ever done, but it will be **worth it**. Trust us

If you're a visual learner, check out our assembly videos! They're pretty great!

YouTube Visit: youtube.com/c/SkywalkerTrampolines

STEP 1

Register your mini trampoline! For info on **warranty registration**, see page 2.

STEP 2

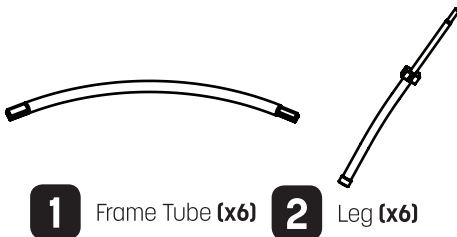

Insert the Frame tube **(1)** into Leg **(1)** as shown.

IMPORTANT: The way the frame tube goes into the leg socket affects how the frame goes together. Place the leg so the bend faces away from you and then insert the larger side of the frame tube into the left hand side of the socket.

See below for example.

Now that you're a pro, repeat this step with the 5 remaining frame tubes and legs.

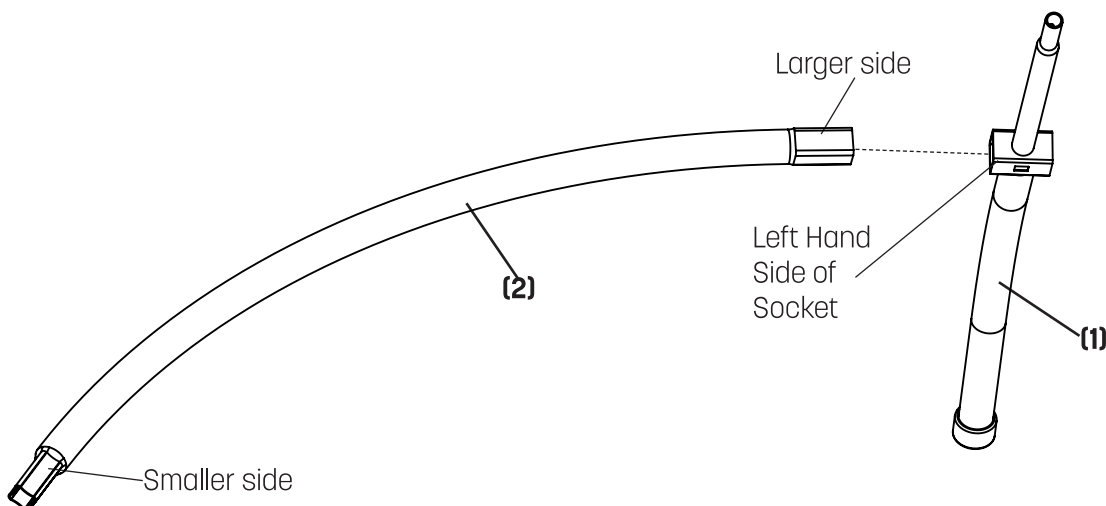

ASSEMBLY

STEP 3

Next, connect all the frame pieces together.

Note: If the bottom of the legs are leaning noticeably inward and not flat on the ground, go back to Step 2 and make sure you assemble the larger side of the frame into the left side of the leg socket with the bend of the leg pointing away from you.

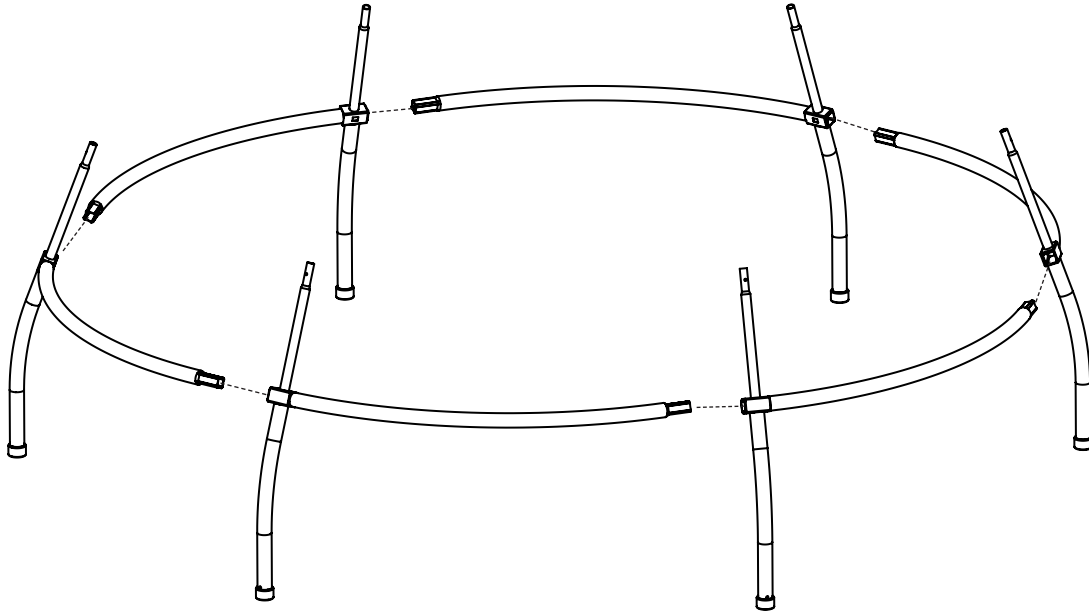

STEP 4



6 Mat with Net (x1)



8 Elastic with Ball (x6)

Place the mat with net **(6)** on the ground inside the frame. Make sure the zipper of the door is centered between the two legs! Then, using one elastic with ball **(8)** attach the mat to the frame in location A. Repeat this step to attach 5 remaining elastic bands in locations B-C-D-E-F as shown. *Follow the example below for the easiest way to attach the stretch bands.*

One elastic band should be centered in between each leg.

Thread the stretch bands all the way through the tab until the ball sits against it

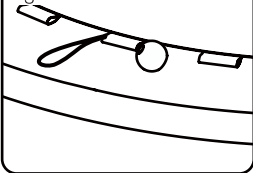

Pull stretch band under and over the Frame Tube and onto the ball

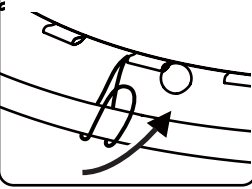

Trust us, your hands will thank you for doing it this way

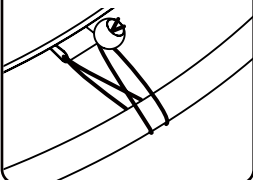

Spend time adjusting the stretch bands so the ball is underneath the Frame Tube

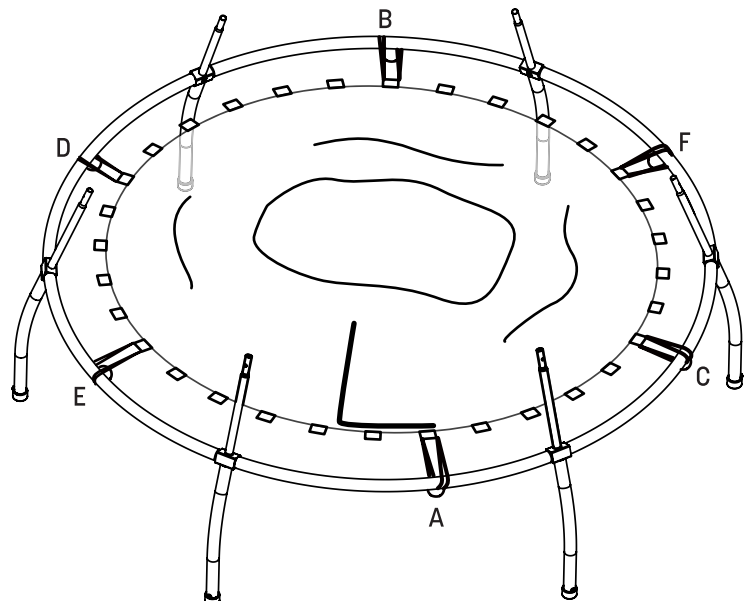
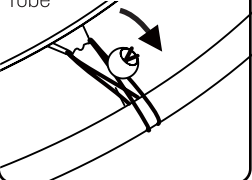

STEP 5

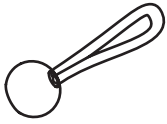

8 Elastic with Ball (x24)

Following the pattern below and beginning with the 7th band, continue to place the elastic bands around the frame in a clockwise direction until all 24 bands are used. **It will get tight as you near the end of attaching the stretch bands and wearing gloves will come in handy at this point to prevent blisters.** Make sure the balls on the elastic bands are located on the underside of the trampoline! After all the elastics have been placed, if the mat is not in the middle of the frame, spend time adjusting the stretch bands.

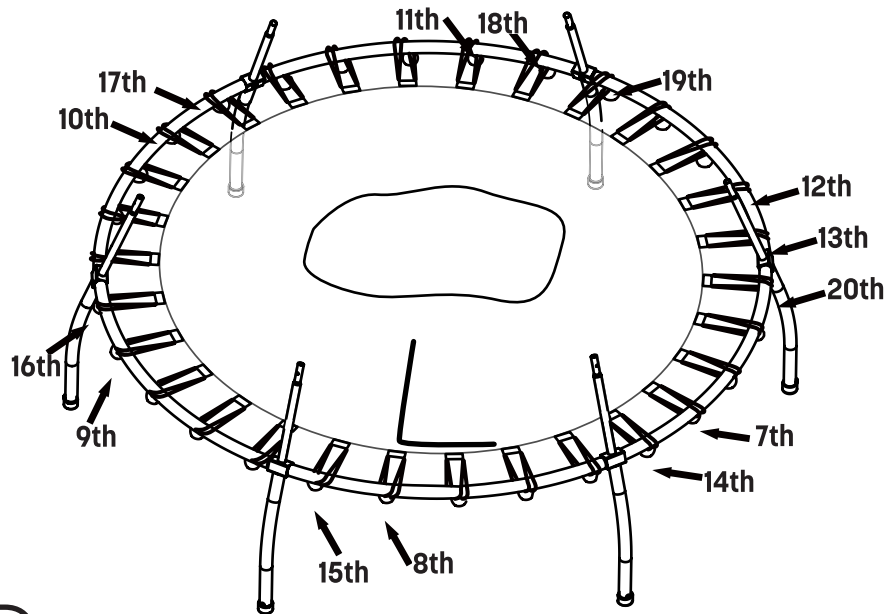

STEP 6

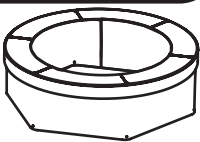

7 Pad with Net (x1)

Lay the pad with net (7) on the frame. Adjust the position of the pad so that the slits are directly above the legs. Pull gently at the seams of the spring pad to find the holes. Insert the top of the legs into the slits of the spring pad.

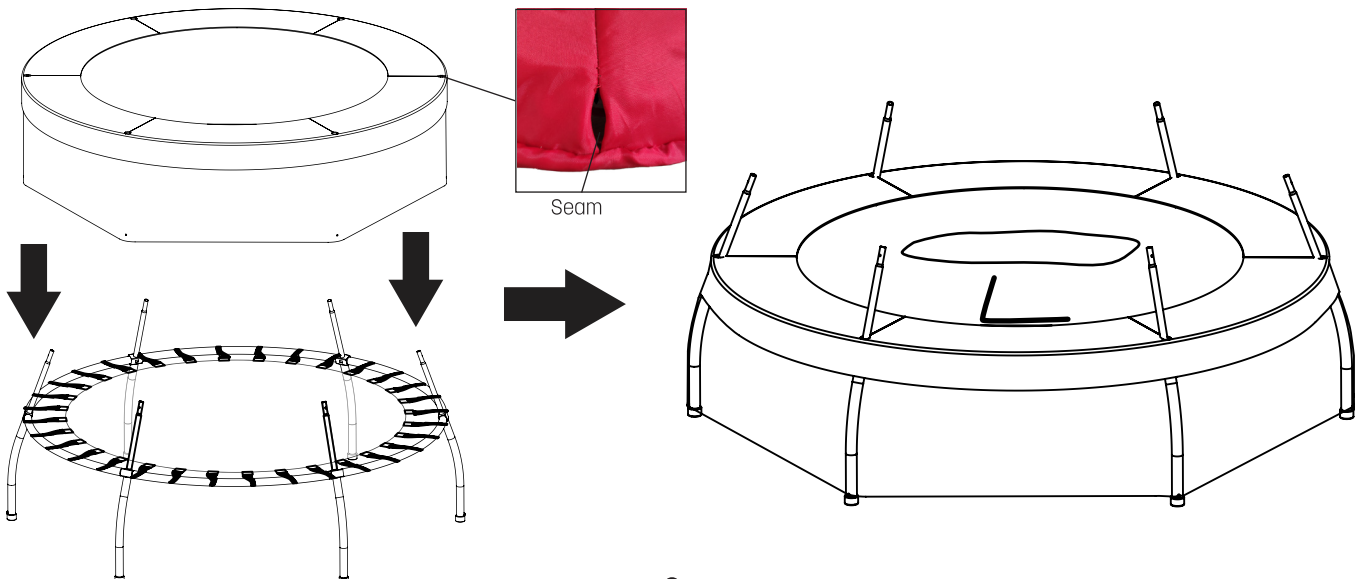

ASSEMBLY

STEP 7

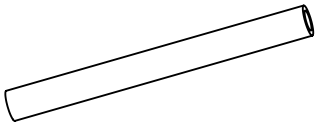

11 Lower foam 8" (205 mm) (x6)

Put the Lower foam (11) onto the tube as shown.

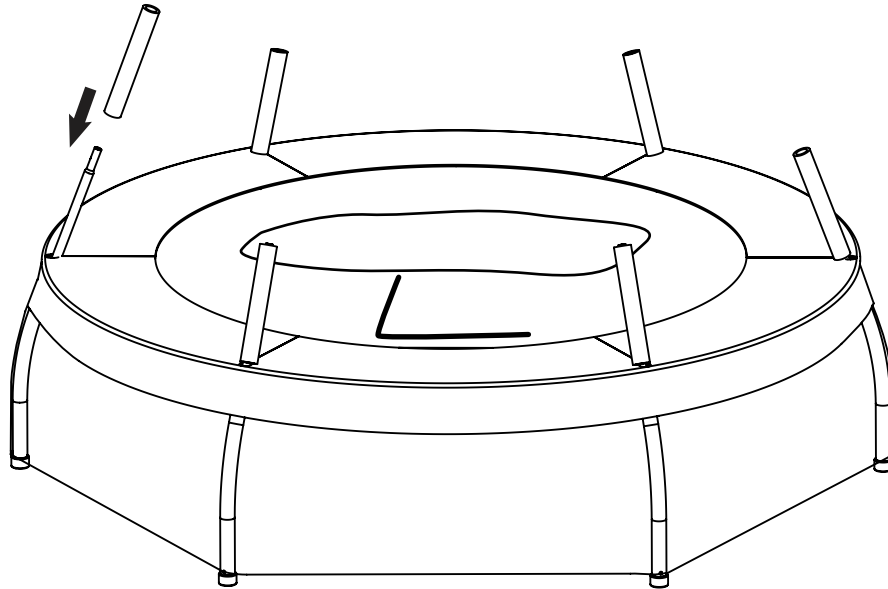

STEP 8



5 Joint (x6)

Unfold the enclosure net attached to the mat, find the hole on net. Slide a Joint (5) into the holes from the inside of net.

Repeat this step until all Joints have been placed inside the net.

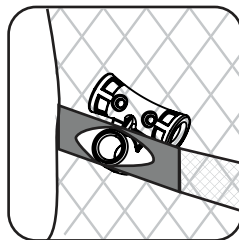
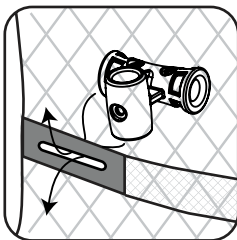

Make sure the joint holes are facing up

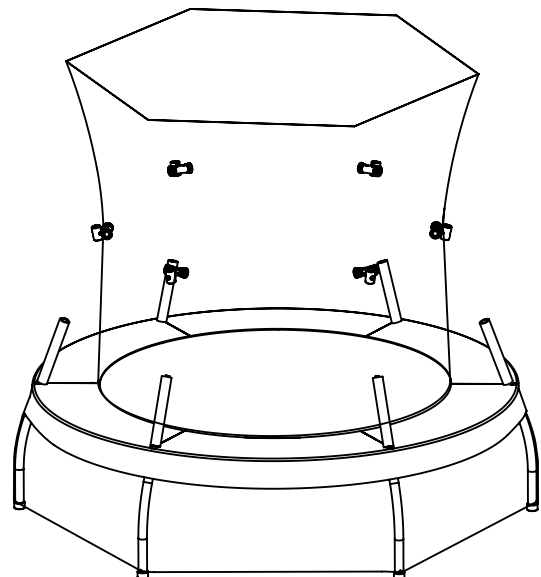
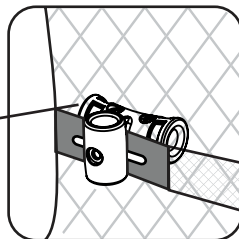

STEP 9

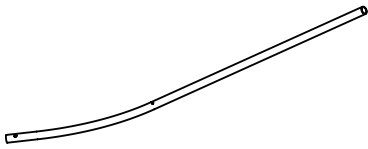

3 Enclosure tube (x1)

Insert the Enclosure tube **(3)** into Joint **(5)** as shown. Make sure the holes are aligned.

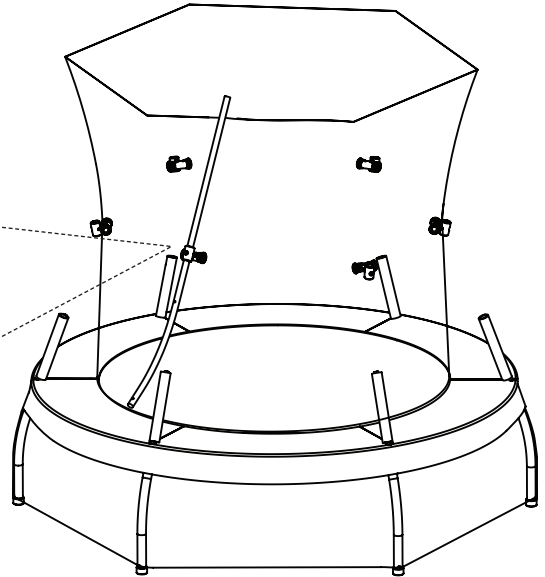
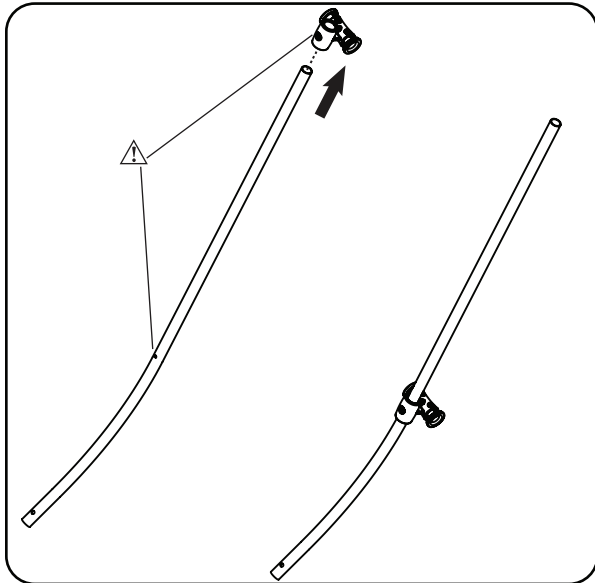

STEP 10

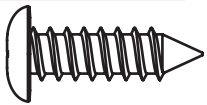

16 Self-tapping Screw (x1)

Secure the Joint and enclosure tube with screws **(16)** as shown.

Note: Unless you're fast with the wrist twist, you might want to use your screwdriver now.

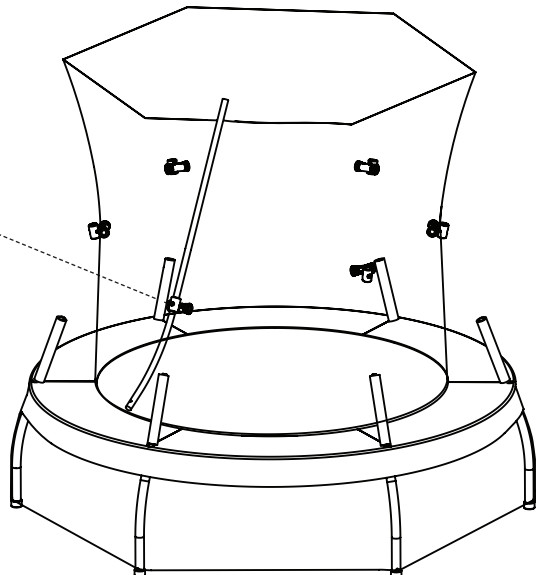
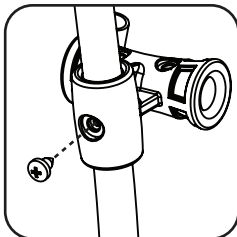

ASSEMBLY

STEP 11

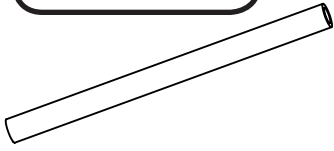

10 Middle foam 11" (302 mm) **(x1)**

Slide the Middle foam **(10)** onto the assembled enclosure tube **(3)** as shown.

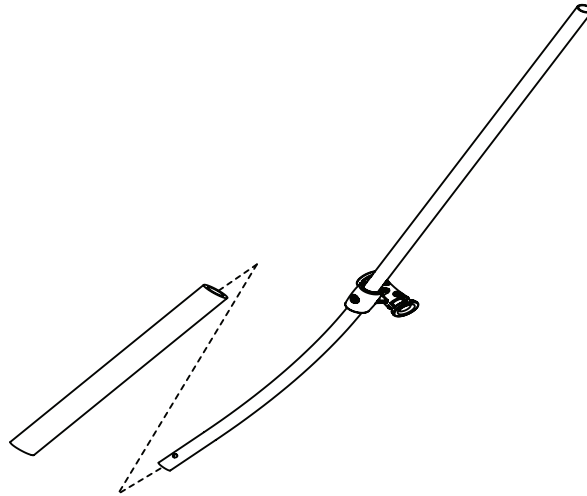

STEP 12

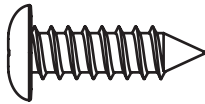

16 Self-tapping Screw **(x1)**

Then put the assembled enclosure tube **(3)** onto the leg tube and secure the joint with screws **(16)** as shown.

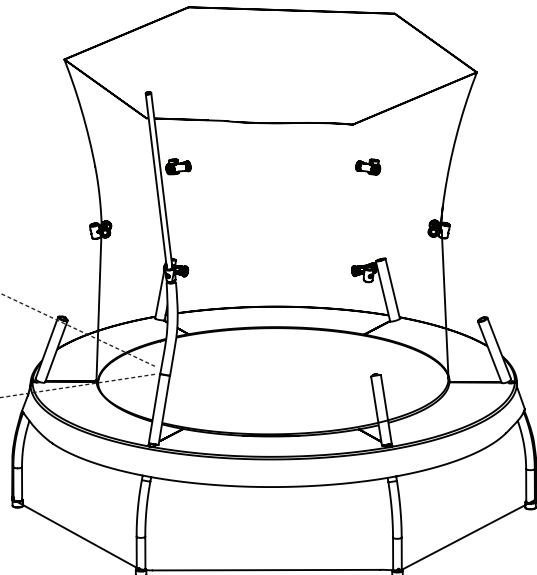
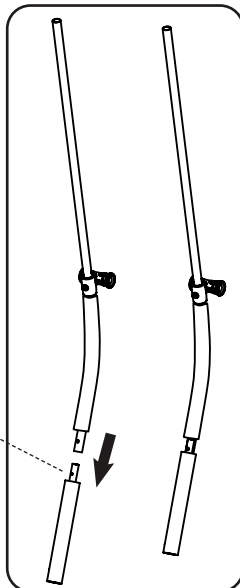
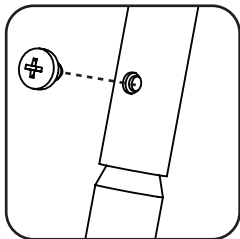

STEP 13

Repeat steps 9-12 to assemble the remaining five Enclosure tubes (3).

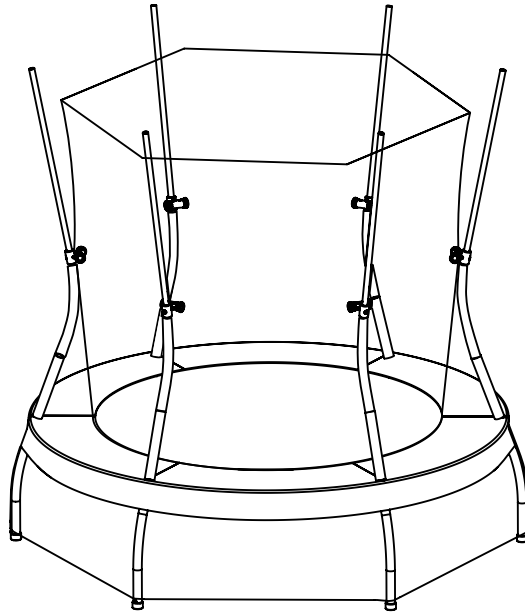

STEP 14

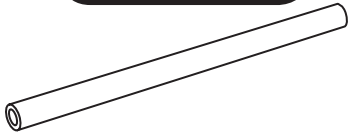

9 Upper foam 21" (545 mm) (x6)

Put the Upper foam (9) onto the enclosure tube as shown.

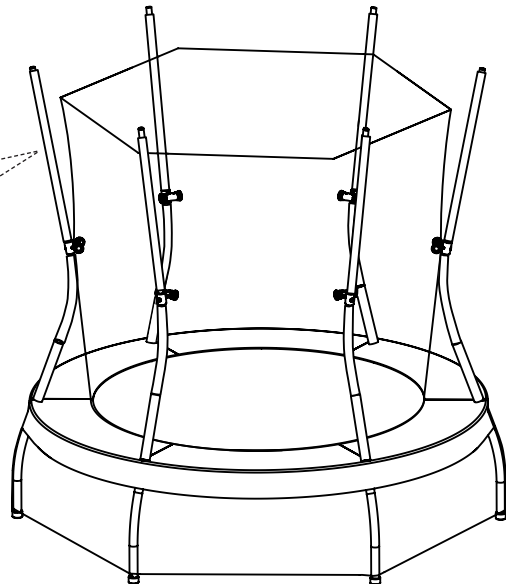
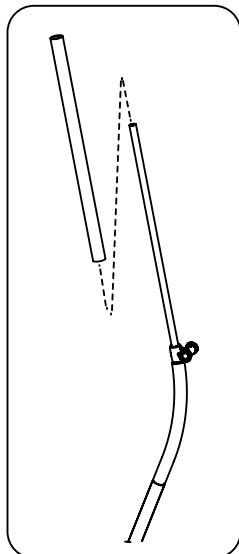

ASSEMBLY

STEP 15

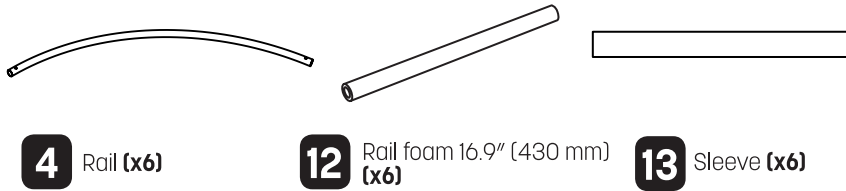

Insert a rail foam **(12)** into the sleeve **(13)**. Then insert the rail **(4)** into the foam with sleeve.

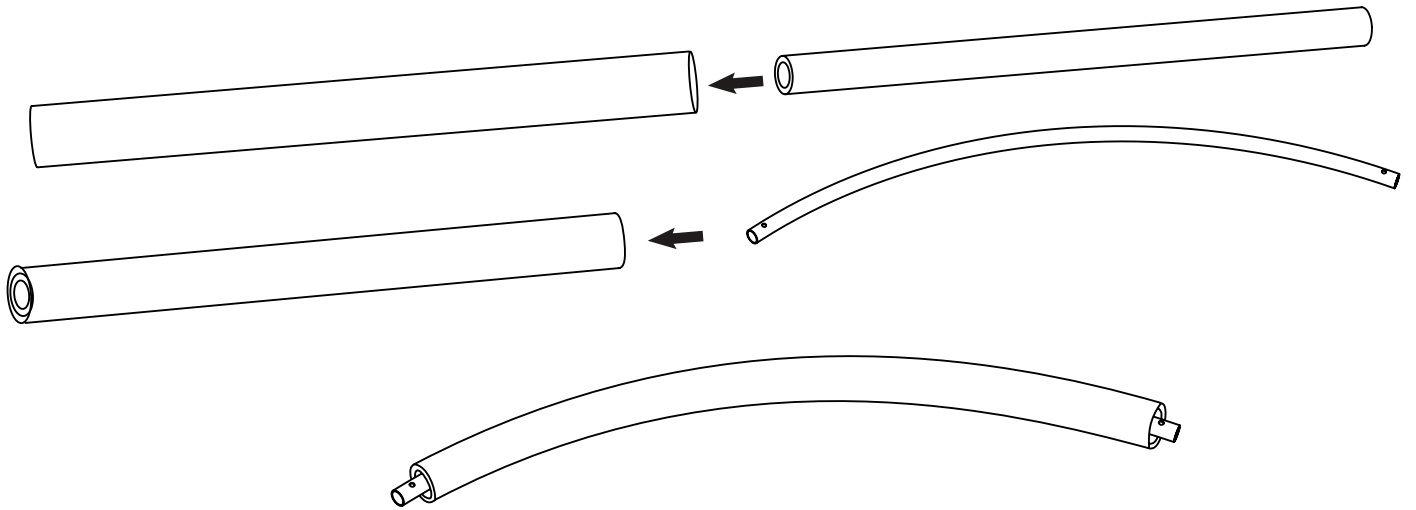

STEP 16

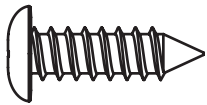

16 Self-tapping Screw (x6)

Insert the one end of the Rail **(2)** into the joint **(5)**. Secure with screw **(16)**.
Note: Leave the other end free as shown.

Repeat to assemble the remaining five rails.

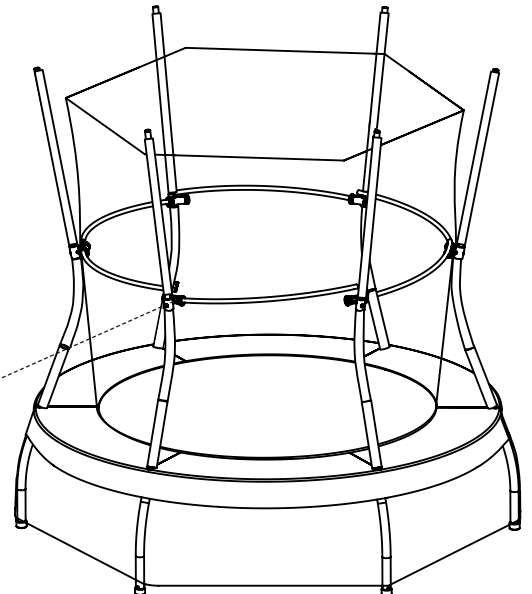
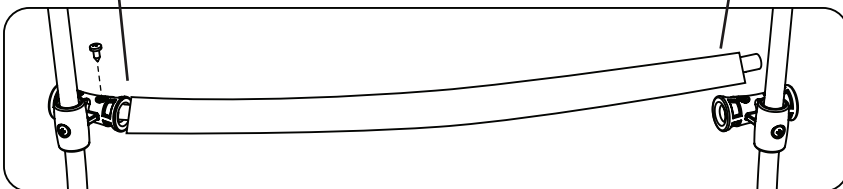
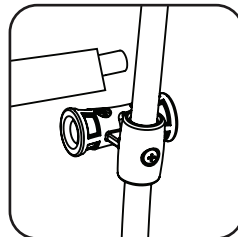
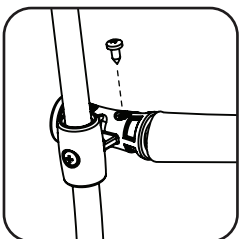

STEP 17

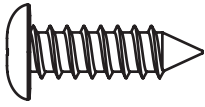

16 Self-tapping Screw (x6)

Insert the other end of the Rail (2) into the joint (5). Secure with screw (16).

Repeat to assemble the remaining five rails.

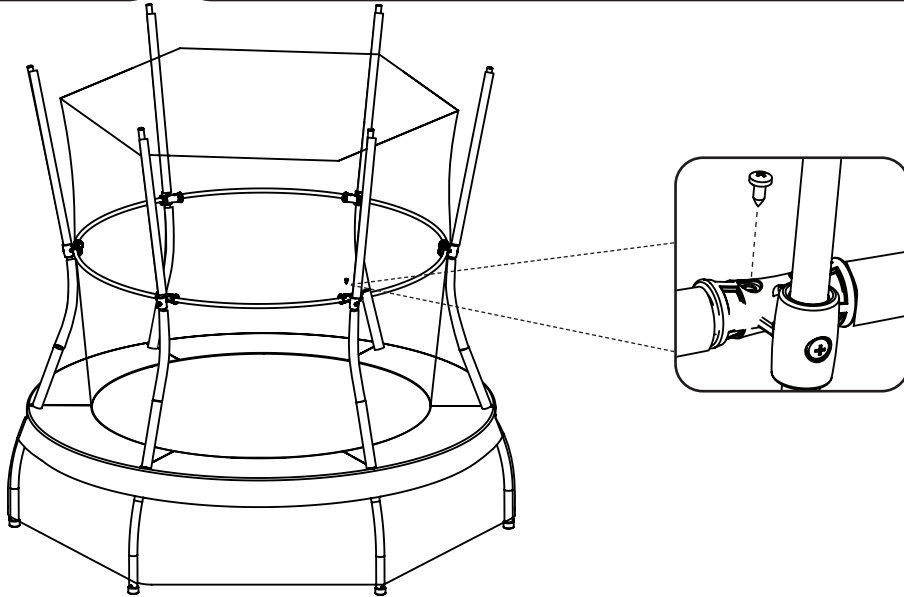

STEP 18



14 Pole Cap (x6)

Now place pole cap (14) on top of the enclosure tube.

Make sure the pole caps are pushed all the way down!

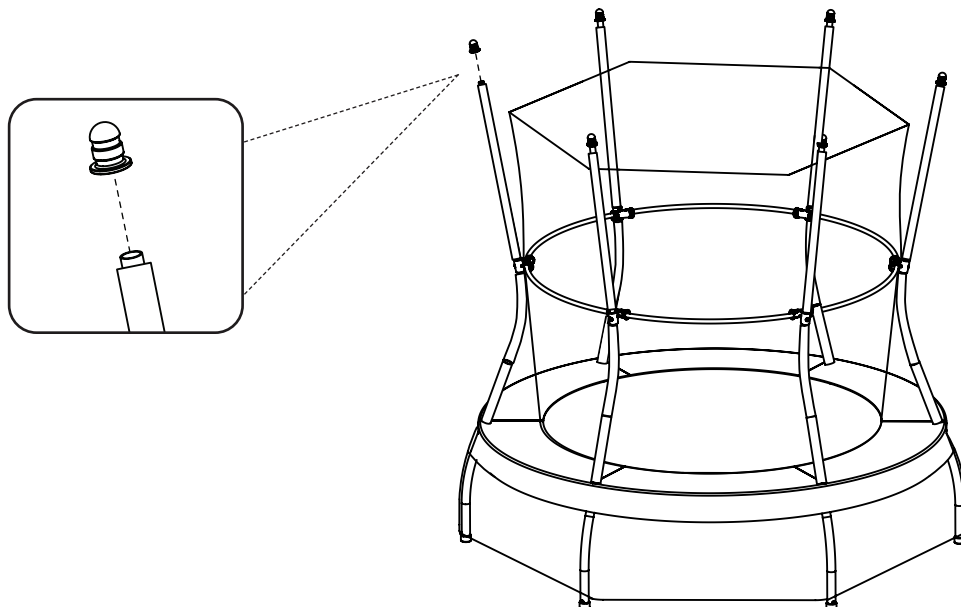

ASSEMBLY

STEP 19

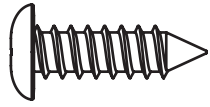

16 Self-tapping Screw (x6)

Place the straps that are at the top of the enclosure net over the pole caps **(14)**.

Insert self-tapping screws **(16)** into the holes at the bottom of the legs. Tighten to secure in place.

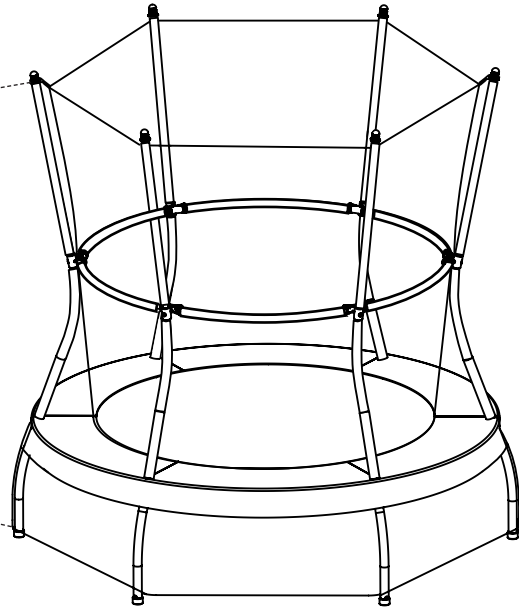
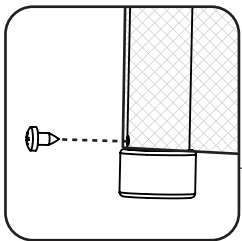
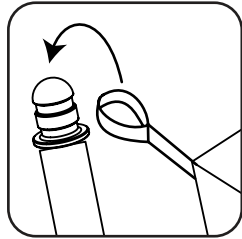

STEP 20

Congratulations on completing your new Mini Bouncer! (See, we knew you could do it!). If you love the product, we want to from hear you! Please leave us a review on the retailer's site you purchased this product from, on our Facebook page, or on any other review site. We'd really appreciate it. If we could, we'd give you a gold star. Are you frustrated or have some suggestions? Contact us directly. We promise we're not trying to ruin your life. We will do everything we can to make it right. See contact info on page 2-3.

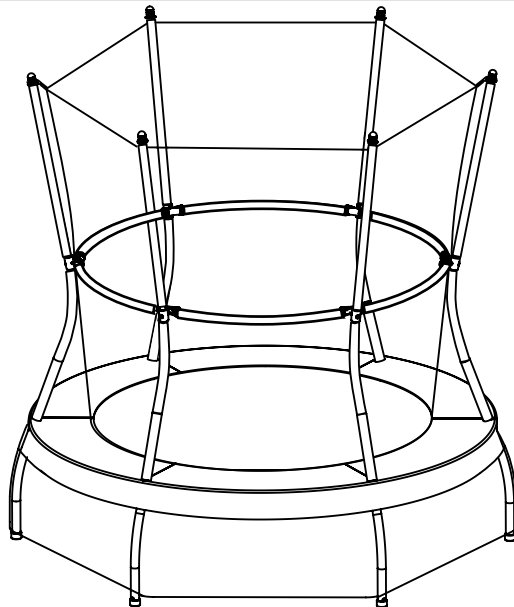

MAINTENANCE & CARE INFORMATION

Congratulations and high five on successfully assembling your new Skywalker Trampolines Mini Bouncer!
Now, the best way to keep your new trampoline in tip-top shape is to check periodically for:

- Missing, improperly positioned, or insecurely attached frame padding, netting, enclosure tubes, or foam sleeves
- Punctures, frays, tears, or holes worn in the mat, frame padding, netting or foam sleeves
- Deterioration in the stitching or fabric of the mat, frame padding or netting
- Ruptured or missing stretch bands
- Bent or broken frame, leg or enclosure tubes
- Sagging bed or netting
- Sharp protrusions on the frame, suspension system or enclosure tubes

If you notice any of the above conditions, please disassemble the enclosure and trampoline until you have ordered new parts.

Don't forget to check us out online! **We'd love to hear from you.**

Website: skywalkertrampolines.com

Facebook: facebook.com/skywalkertrampolines

YouTube: youtube.com/channel/UCUty7EqwIGouK5ovzGpHGrw/feed

Pinterest: pinterest.com/swtrampolines

Twitter: twitter.com/swtrampolines?lang=en

Instagram: instagram.com/skywalker_trampolines/?hl=en

WARNING LABEL PLACEMENT

The placard shown above was sewn to the trampoline enclosure netting.

Note: The labels and placard shown are not actual size.

The labels shown on this page have been attached to the trampoline in the indicated locations. The safety instructions placard will need to be attached by the owner. If one of the labels or the placard is missing or illegible, call our Customer Care Hot Line toll-free at 1-866-603-JUMP (5867), Monday through Thursday, 8 a.m. until 5 p.m., Friday 8 a.m. to 3 p.m. Mountain Time, to order a free replacement label or placard.

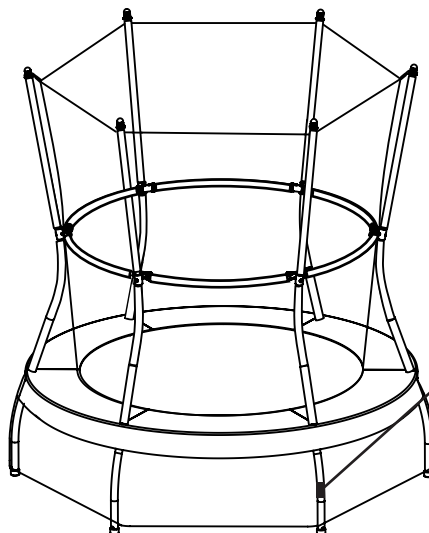

 **WARNING**

- Do not use without frame pads.
- Do not attempt or allow somersaults. Landing on the head or neck can cause serious injury, paralysis, or death, even when landing in the middle of the bed.
- Inspect the trampoline and parts before use. Replace any worn or damaged parts.
- One person on the trampoline at a time. Use by more than one person at the same time increases the chances of injury.
- Use trampoline only with mature, knowledgeable supervision.

INSTRUCTIONS FOR USE

To reduce the risk of serious injury, read and follow all of the warnings, precautions, and instructions in this manual before you use the trampoline enclosure. Warnings and instructions for care, maintenance, and use of this trampoline and enclosure are included to promote safe enjoyable use of this equipment.

1. It is the responsibility of the owner and supervisors of the trampoline and enclosure to make sure all users obey the safety instructions given in this manual. The trampoline should only be used with mature, knowledgeable supervision.
2. Secure the trampoline and trampoline enclosure against unauthorized and unsupervised use. If you use a ladder to get on and off the trampoline, be sure to remove it when the trampoline and enclosure are not being used.
3. Be sure there is enough clear space above the trampoline and enclosure before use. It is best to have at least 24 feet (7.3 meters) of clear space above the ground. This space must be clear of wires, tree limbs, and any other possible hazards.
4. Lateral (sideways) clearance is very important. Do not place the trampoline and enclosure near walls, buildings, fences, sidewalks, and other play areas. Always keep a clear space on all sides of the trampoline and enclosure.
5. Remove any objects that could interfere with the performer. Maintain a clear area around and under the trampoline.
6. Be sure the trampoline and enclosure are on a level surface before use.
7. Always inspect the trampoline and enclosure before each use. Make sure that the frame, padding, netting, enclosure tubes, and foam sleeves are correctly and securely positioned. Replace any worn, defective, or missing parts. (Jumpers may be hurt if the trampoline and enclosure are used when they are in poor condition.)
8. Bounce only when the surface of the mat (bed) is dry. There should be very little or no wind or air movement. The trampoline and enclosure must not be used in gusty or severe winds.
9. The trampoline and enclosure frames are made of metal. They are not grounded and will conduct electricity. For this reason, an electrocution hazard exists. No lights, electric heaters, extension cords, or household electrical appliances are to be permitted on the trampoline or in enclosure at any time.
10. Use the trampoline and enclosure in an area with lots of light. If the trampoline and enclosure are indoors or in shady areas, you may need to use artificial (electrical) lighting in the area.
11. During the winter months, the trampoline soft materials will need to be removed and stored in a dry place. If left up in the winter months, it may cause damage to the springs, jump mat, spring pad, and enclosure. The warranty will be void.
12. This trampoline and enclosure is made for users who weigh less than 100 lbs.
13. This Trampoline is designed for 3-7 years of age
14. The trampoline enclosure is to be used only with the size of trampoline for which the enclosure is designed.
15. Misuse and abuse of the trampoline enclosure is dangerous and can cause serious injury.
16. Do not attach anything to the enclosure barrier that is not a manufacturer-approved accessory or part of the enclosure system.
17. Please remove any jewelry before jumping begins. Jewelry may get caught in the enclosure netting.
18. Wear clothing free of drawstrings, hooks, loops, or anything that could be caught while using the trampoline/enclosure and result in entanglement, strangulation, or both.
19. Do not let more than one person inside the trampoline enclosure at the same time. Two or more people jumping at the same time can cause serious injury.
20. Do not jump on the trampoline while you have or are holding any objects, especially something sharp or breakable.
21. Do not use the trampoline and enclosure if you have been using alcohol or drugs.
22. Do not attempt or allow somersaults (flips) on the trampoline. Landing on the head or neck can cause serious injury, paralysis, or death, even when landing in the middle of the jumping mat.
23. Always climb on to and off of the trampoline. It is a dangerous practice to jump from the trampoline to the floor or ground when dismounting, or to jump onto the trampoline when mounting.
24. Do not use the trampoline as a springboard to other objects. Enter and exit the enclosure only at the enclosure door or barrier made for that purpose.
25. Do not attempt to crawl under, jump over, intentionally bounce off of, hang from, climb on, kick, or cut the barrier netting.
26. While keeping head erect, focus eyes on the trampoline toward the perimeter. This will help control bounce.
27. Stop bouncing by flexing knees as feet come in contact with the trampoline bed. Learn this skill before attempting others.
28. Avoid bouncing too high. Stay low until bounce control and repeated landings in the center of the trampoline can be accomplished. Control is more important than height.
29. Avoid bouncing when tired. Keep turns short.
30. Learn fundamental bounces and body positions thoroughly before trying more advanced skills. A variety of trampoline activities can be carried out performing the basic fundamentals in various series and combinations, performing one fundamental after another, with feet bounces between them.
31. For additional information concerning the trampoline equipment contact the manufacturer. For information concerning skill training, contact a certified trampoline instructor.
32. Do not use or stand near the trampoline in windy or gusty conditions. A trampoline can become airborne when exposed to sustained wind or gusting wind conditions. This can result in serious injury, paralysis, or death, as well as property damage. To reduce these risks, disassemble the trampoline and enclosure and store them until weather conditions improve. Anchoring a trampoline frame may prevent the trampoline from moving as a result of the wind, but even anchored trampolines can become airborne or damaged. Consult a qualified contractor to determine what type of anchor works best in your location.

METHODS OF ACCIDENT PREVENTION

THE SUPERVISOR'S ROLE IN PREVENTING ACCIDENTS

It is the responsibility of the supervisors of trampoline users to provide knowledgeable and mature supervision. They need to know and enforce all of the rules and warnings printed in this manual to minimize the likelihood of accidents and injuries. They also need to inform users of these rules. During periods of time when supervision is unavailable or inadequate, this may require that the trampoline is taken down, placed in a secure area, or otherwise secured against unauthorized use. Another option that may be considered is covering the trampoline with a heavy tarp that can be secured with locks and chains. It is the responsibility of the supervisor to make sure that the placard with trampoline safety instructions is kept posted on the trampoline and that jumpers are informed about these instructions.

THE JUMPER'S ROLE IN PREVENTING ACCIDENTS

Education on the part of the user is a must for safety. Users must first learn a low, controlled bounce and then learn the basic landing positions and combinations before proceeding to intermediate skills. Jumpers must understand why they have to master "control" before they can start thinking about other moves. Understanding the proper progression of skills in jumping on a trampoline must be the first lesson. Review this manual to learn about the basic techniques for using the trampoline. For further information or additional instructional materials, contact a certified trampoline instructor.

TRAMPOLINE SAFETY INSTRUCTIONS

For the Supervisor

Read the instructions before using the trampoline. Enforce all of the safety rules. Become familiar with the information in this manual so you can help new users learn basic jumps and all users follow trampoline safety. All trampoline users must have mature, knowledgeable supervision, regardless of their skill or age. This trampoline is not recommended for use by children under 6 years of age. Inspect the trampoline before using it. Do not use the trampoline without the frame pad securely in place to cover the frame. Do not use the trampoline in wet or windy conditions. A worn or damaged mat, spring, or frame piece should be replaced immediately.

Jumping

Learn fundamental jumps and body positions thoroughly before trying more advanced skills. Know your own limits in performing each of the trampoline jumps. Study this manual to learn how to do basic jumps. Stop your bounce by flexing your knees as your feet come in contact with the trampoline mat. Learn this skill before attempting any others.

INSTRUCTIONS & MODEL LESSONS

The following lessons are examples of an instructional program. They should follow a complete discussion and demonstration of body mechanics between the supervision and the student(s).

1. Mounting and dismounting: Demonstration and practice of proper techniques.
2. Fundamental bounce: Demonstration and practice.
3. Breaking: Demonstration and practice. Breaking on command.
4. Hand and knee drop: Demonstration and practice, stressing four-point landing and alignment.

Lesson 1: Fundamental Bounce

1. Start from a standing position with your head erect and your eyes on the frame pad.
2. Swing your arms forward and up in a circular motion.
3. Bring your feet together and point your toes downward while in the air.
4. Keep your feet about 15 inches apart when landing on the mat.

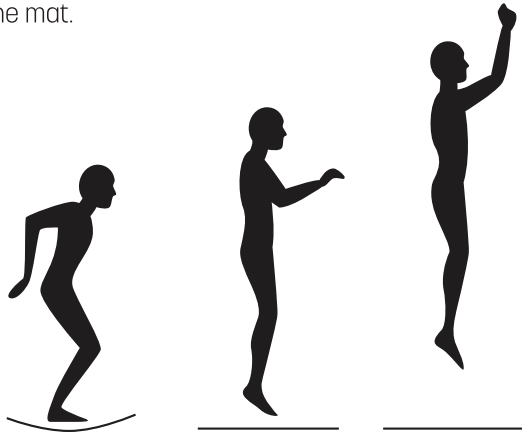

Lesson 2: Knee Drop

1. Start bouncing from a standing position, keeping your eyes on the frame pad.
2. Land on your knees, keeping your back straight and your body erect.
3. Come back up to an erect position.

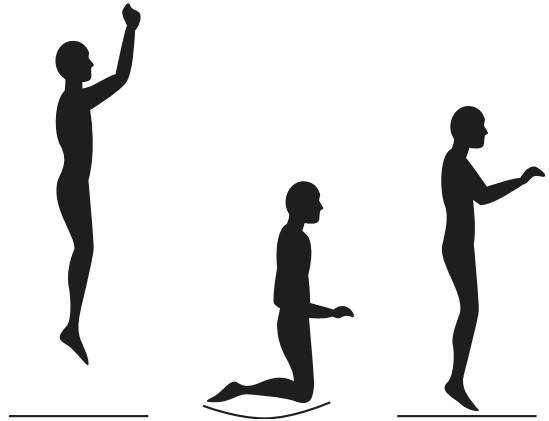

Lesson 3: Hand and Knee Drop

1. Start bouncing from a standing position, keeping your eyes on the frame pad.
2. Land on the mat on your hands and knees.
3. Push with your hands and come back up to an erect position.

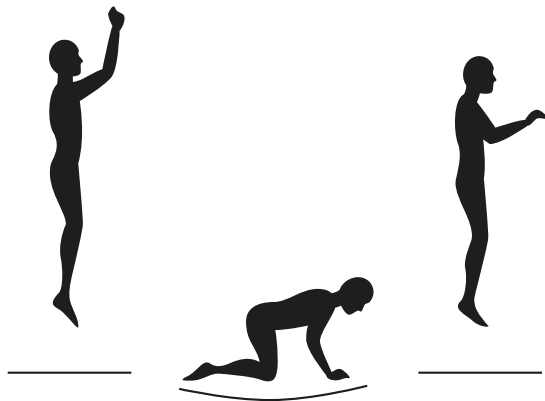

Lesson 4: Back Drop

1. Start from a low bounce and land on your back.
2. Keep your chin forward on your chest as you land.
3. Kick forward and up with your legs to return to an erect position.

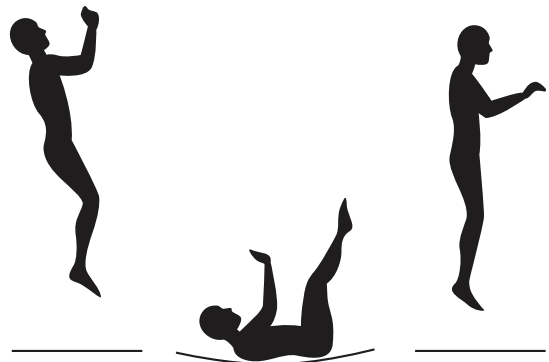

Lesson 5: Seat Drop

1. Land in a sitting position with your legs parallel to the mat.
2. Place your hands on the mat beside your hips.
3. Push with your hands to return to an erect position.

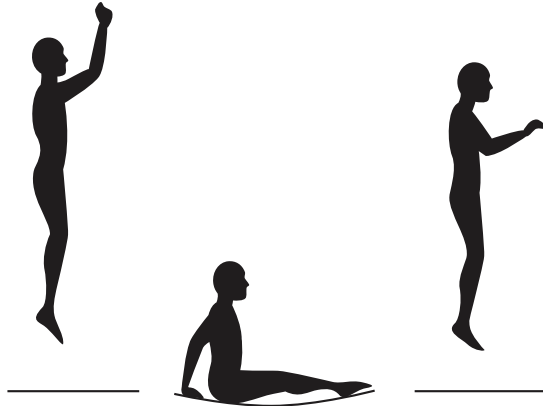

Lesson 6: Front Drop

1. Start from a low bounce and land on the mat in a prone position.
2. Keep your head up and your arms extended forward on the mat.
3. Push with your arms to return to an erect position.

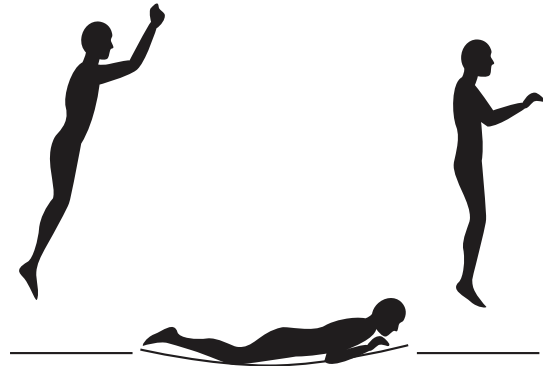

Lesson 7: Half Turntable

1. Start from the front drop position and push to the left or right with your arms turning your body in the opposite direction.
2. Turn your head and shoulders toward the direction that your body is turning.
3. Keep your back parallel to the mat and your head up.
4. After completing a half turn, land in the front drop position.

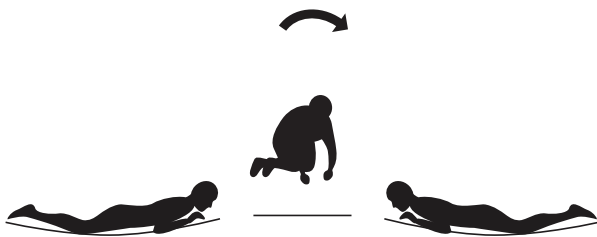

Lesson 8: Swivel Hips

1. Start with a seat drop.
2. Turn your head to the left or right and swing your arms up in the same direction.
3. Turn your hips in the same direction as your head and arms, completing a twist.
4. Land in the seat drop position.
5. Keep your back parallel to the mat and your head up.
6. After completing a half turn, land in the front drop position.



Once each of lessons are learned, the student should now be encouraged to design and organize routines, with emphasis on good form. The instructor may judge or grade students and arrange groupings for further instruction accordingly.

To stimulate interest in competition, the game of "Trampoline Horse" can be introduced. Before the game begins, students must count off. To start the game, student number 1 performs a stunt. Student number 2 then mounts the trampoline, performs the same stunt and adds a second stunt. Student number 3 mounts and performs stunts 1 and 2 and adds a third stunt. Thus the series of stunts is continuously lengthened. The first person to miss a stunt in the series assumes the letter "H" and starts a new series with a stunt. If a person misses again, he assumes the letter "O." When a person accumulates "H-O-R-S-E," he or she is eliminated from the game. The last remaining contestant is the winner. Lesson planning from this point on should be facilitated by contacting a certified trampoline instructor.

TRAMPOLINE SAFETY INFORMATION

In trampoline use, as in all active recreational sports, participants can be injured. However, there are steps that can be taken to reduce risk of injury. In this section, primary accident patterns are identified and the responsibilities of supervisors and jumpers in accident prevention are described.

ACCIDENT CLASSIFICATION

Somersaults (flips): Landing on your head or neck, even in the middle of the trampoline mat, increases the risk of a broken back or neck, which can result in paralysis or death. Such events can occur when a jumper makes an error trying to perform a forward or backward somersault (flip). Do not perform somersaults(flips) on this backyard trampoline.

Multiple Jumpers: More than one jumper at a time on the trampoline increases the chance of a jumper becoming injured by losing control of his or her jump. Jumpers may collide with one another, fall off of the trampoline, fall onto or through the springs, or land incorrectly on the mat. The jumper weighing the least is the jumper most likely to be injured.

Mounting and Dismounting (Getting on and off): The trampoline mat is several feet above ground level. Jumping from the trampoline to the ground or any other surface may result in injury. Jumping onto the trampoline from a roof, deck, or other objects also presents a risk of injury. Smaller children may need assistance getting onto or down from the trampoline. Climb carefully onto and off of the trampoline. Do not step onto the springs or the frame pad. Do not grasp the frame pad to pull yourself onto the trampoline.

Striking the Frame or the Stretch Bands: Injury may result from hitting the frame or falling through the springs while jumping or getting onto or off of the trampoline. Stay in the center of the mat when jumping. Be sure to keep the frame pad in place to cover the frame. The frame pad is not made or intended to support the weight of trampoline user. Do not step or jump directly on the frame pad.

Loss of Control: Jumpers who lose control of their jumps may land on the mat incorrectly, land on the frame or springs, or fall off of the trampoline. A controlled jump is one where the landing is in the same spot as the takeoff. Before learning a more difficult stunt, you should be able to do one over an over with control. Attempting a stunt beyond present skill levels increases the chance of loss of control. To regain control and stop your jump bend your knees sharply when you land.

Alcohol or Drug Use: The chance of injury increases when a jumper has consumed alcohol or taken drugs. These substances impair a person's reaction time, judgment, and physical coordination.

Encountering Objects: Jumping on a trampoline while other people, pets, or objects are underneath it will increase the chance of getting hurt. Jumping while holding or having an object on the trampoline, particularly one that is sharp or breakable, will increase the chance of injury. Placing a trampoline too close to overhead electrical wires, tree limbs, or other objects can increase the chance of injury.

Poor Maintenance of The Trampoline: Jumpers may be injured if a trampoline is in poor condition. A torn mat, bent frame, broken spring, or missing frame pad, for example, should be replaced before anyone is allowed to jump. Inspect the trampoline before each use.

Access: To prevent access to the trampoline by unsupervised smaller children, the optional access ladder should always be taken away and stored in a safe place when the trampoline is not in use.

ENCLOSURE SAFETY INFORMATION

NEED FOR TRAMPOLINE ENCLOSURE SAFETY

A trampoline enclosure is a recreational product. The information on this page identifies important safety precautions. The precautions are not all-inclusive, because an enclosure can be used in ways that this manual cannot cover completely.

To prevent pinches and cuts during enclosure use, a frame pad must be installed on the trampoline (see the trampoline manufacturer's instructions). The frame pad must be placed on the trampoline before the enclosure is erected. The frame pad reduces the chance of injury from accidental contact with the springs and frame.

USING THE ENCLOSURE SAFELY

Adult Supervision of Children

Children using a trampoline with a trampoline enclosure must be supervised by adults. Young children must be supervised constantly. Adults must pay particular attention to:

- Things that children bring into the enclosure
- Children's activities inside the enclosure
- Conditions inside the enclosure while children are using it
- The way children enter and exit the enclosure

Additional details of safety enclosure use are described below:

Electrocution Hazard Associated with the Metal Frame of the Trampoline and Enclosure

The trampoline and enclosure frames are made of galvanized steel. They are not grounded and will conduct electricity. For this reason, an electrocution hazard exists. No lights, electric heaters, extension cords, or household electrical appliances are to be permitted on the trampoline or in the enclosure at any time.

Hazards Associated with Entering and Exiting the Trampoline Enclosure

A trampoline enclosure installed on a trampoline is raised off the ground. The height of the enclosure increases the risk of a fall when a jumper is entering or leaving the enclosure. Young children especially may have difficulty entering and exiting the enclosure. To reduce the risk of falling, always help young children to get into and out of the enclosure.

Enter and exit the trampoline enclosure only through the door of the enclosure (the opening in the netting walls). The trampoline mat (bed) and the netting walls of the enclosure are separate pieces. No jumper, especially young children, should ever leave the enclosure by going out between the mat and the netting walls. Trying to get out this way creates a risk of choking from being caught between the trampoline frame and the netting walls.

Darkness increases the chances of a fall when a jumper is entering or leaving the enclosure. Do not use the trampoline unless there is plenty of lighting provided.

Hazards Associated with Animals, Sharp or Breakable Objects

To avoid damage to the trampoline enclosure and the trampoline, do not allow pets or other animals inside of the enclosure. The claws and teeth of animals can damage the netting. Do not jump on the trampoline while holding or wearing a sharp or breakable object.

LIMITED WARRANTY

Skywalker Holdings, LLC warrants its products to be free from defects in material and workmanship under normal use and service conditions. **The steel frame is warranted for three (3) years after the date of purchase. All other parts are warranted for one (1) year after the date of purchase.** Warranty coverage extends only to the original retail purchaser from the date of original purchase. This warranty is only valid concerning products used for residential use. Products used for commercial use, such as schools and daycares, will not be covered.

WHAT IS NOT COVERED?



Weather Damage: The warranty does not cover damage due to the effects or acts of nature, such as earthquakes, wind, hurricanes, tornadoes, lightening, rain, fire, snow, excessive heat and cold conditions and/or sun damage. During the winter months the trampoline soft materials will need to be removed and stored in a dry place out of the snow. If left unprotected in the winter months, some components such as springs, jump mat, spring pad and enclosure, may become damaged, voiding this warranty.



Fading and Rust: Our products are fully galvanized. Skywalker does not warranty against rust or corrosion. Some areas may have higher air salt content, higher humidity, heavier rain and heavier snow. Skywalker does not warranty against fading. We suggests customers use a UV protectant on the frame pad to extend the life of the product.



Loss or Damage to Product: caused by shipping, abuse, misuse, improper/abnormal usage or unauthorized repairs are not covered by this warranty and may also void the warranty.



Unauthorized Replacement Parts: The warranty will become void if any defects or damages are associated with the use of unauthorized replacement parts. All replacement parts must be obtained from an authorized agent.



Assembly Service: The warranty does not cover acts or omissions provided by a third-party assembly service. It is the customer's responsibility to check all boxes and confirm all components are included and in their proper condition before installation occurs.

INSPECTION AND REPLACEMENT PARTS:

1. Your trampoline should be inspected upon unpacking and set up and thereafter on a regular basis. Worn, damaged or broken parts should be replaced immediately and before use.
2. Call the Skywalker Trampoline Customer Service Department at 1-866-603-5867 to file a warranty claim. Be prepared to provide the following information: name, shipping address, a copy of your original sales receipt, a brief description of the problem and cause, trampoline model number and serial number. We may also ask for photos of the damaged/defective parts.
3. Customer service will review your claim and contact you with further instruction.

NOTE: All requested information must be provided in order to review your warranty claim.

To order replacement parts for your product please visit www.skywalkertrampolines.com

Skywalker Holdings, LLC, PO Box 574, Brigham City, UT 84302 USA.

Printed in China © 2019 Skywalker Holdings, LLC

NOTE: Skywalker Holdings, LLC is not responsible or liable for indirect, special or consequential damages arising out of or in connection with the use or performance of the product or other damages with respect to any economical loss, loss of property, loss of revenue or profits, loss of enjoyment or use, cost of removal, installation or other consequential damages. Some states do not allow the exclusion or limitation of incidental or consequential damages. Accordingly, the above limitation may not apply to you.

The warranty extended herunder is in lieu of all other warranties and any implied warranty of merchantability or fitness for a particular purpose is limited in its scope and duration to the terms set forth herein. Some states or countries do not allow limitations and how long an implied warranty lasts. Accordingly, the above limitations may not apply to you. This warranty gives you specific legal rights. You may also have other rights which vary state to state or country to country. This warranty is valid only in the country the product was purchased.

This warranty is valid only in the country the product was purchased.

