

N729P183735

WF319798

**ASSEMBLY INSTRUCTIONS
(INSTRUCTIONS DE MONTAGE)
36 INCH BATH VANITY (COMBO)**

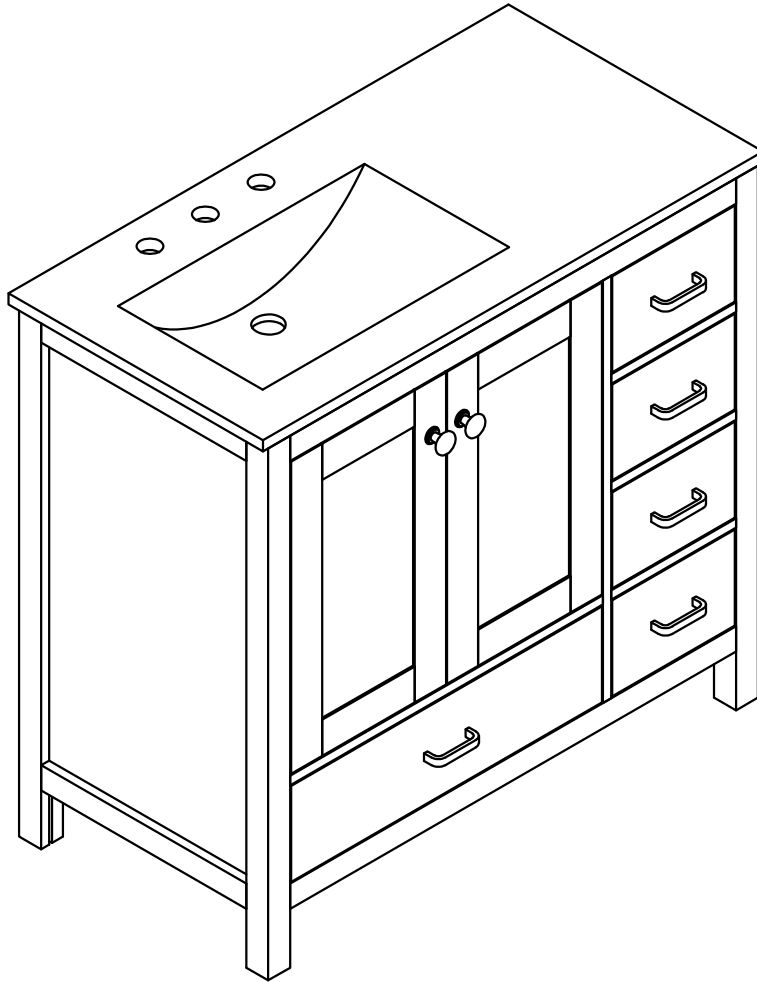

Thank you for purchasing this quality product. Be sure to check all packaging material carefully for small parts which may have come loose inside the carton during shipment. Separate, identify and count all parts and hardware. Compare with the parts list to be sure all parts are present.

"DO NOT TIGHTEN SCREWS UNTIL COMPLETELY ASSEMBLED"

Merci d'avoir acheté ce produit de qualité. Assurez-vous de vérifier soigneusement tout le matériel d'emballage pour détecter les petites pièces qui auraient pu se détacher à l'intérieur du carton pendant le transport. Séparez, identifiez et comptez toutes les pièces et le matériel. Comparez avec la liste des pièces pour vous assurer que toutes les pièces sont présentes.

"NE SERREZ PAS LES VIS AVANT D'ÊTRE COMPLÈTEMENT ASSEMBLÉES"

- Use of power tool to assemble this product will invalidate any claim and damage this product making unsafe !!!
- Please assemble on a clean soft surface to avoid damage.

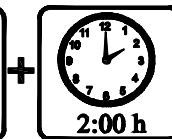
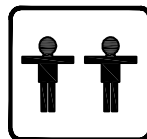
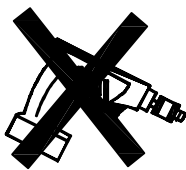

Tools Required

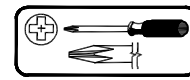

(Not Included)

IMPORTANT:

**PLEASE READ INSTRUCTION BEFORE STARTING THE ASSEMBLY
VEUILLEZ LIRE LES INSTRUCTIONS AVANT DE COMMENCER L'ASSEMBLAGE**

Before Installation

Important - Please read these instructions fully before starting assembly

Thank you for purchasing this quality product. Be sure to check all packing materials carefully for small parts, which may have come loose inside the carton during shipment. Identify and count all items according to the PARTS LIST and/or HARDWARE LIST shown below. Check you have all the components and tools listed on the following pages.

- . We recommend that you assemble this product with the assistance of another person; this will make the assembly easier, and will help eliminate damage to the product or injury to persons during assembly.
- . Please do not over tighten screws or bolts until the assembly is completed.
- . Keep children and animal away from the work area, small parts could choke if swallowed.
- . Please put all parts on a non-abrasive floor before assembly, and follow the assembly steps to assemble your newly purchased product correctly and efficiently.

If you find that you have any trouble with assembly or missing or damaged parts please contact the seller.

Cam Lock Assembly Instructions

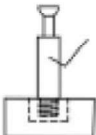
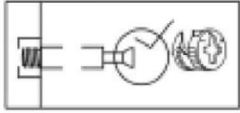
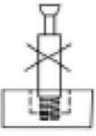
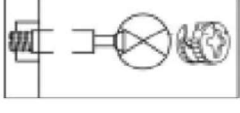
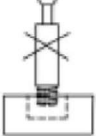
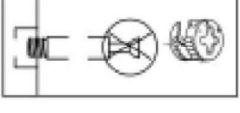
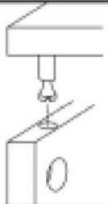
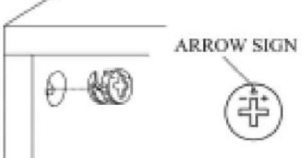
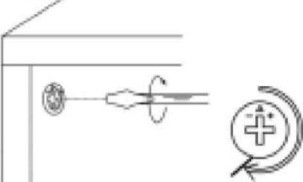
		Diagram A Insert Cam Bolt into hole as shown in diagram A.
		Diagram B Make sure not to insert the Cam Bolt: Too deep as shown in figure B as this will cause the Cam Lock to be misaligned and unable to interlock properly.
		Diagram C Also avoid inserting the Cam Bolt too close to the surface of the hole as shown in figure C, as this will cause the Cam Lock to be too loose, and not interlock properly.
		Connect the panels together.
		ARROW SIGN Insert the Cam Lock so the side opening fits over the head of the Cam Bolt.
		To tighten the Cam Lock, turn it clockwise on half a turn with a flat screwdriver. <i>*Do not use an automatic screwdriver as it may bend or break if too much power is imposed.</i>

Before Installation

Important - Veuillez lire entièrement ces instructions avant de commencer l'assemblage.

Merci d'avoir acheté ce produit de qualité. Assurez-vous de vérifier soigneusement tous les matériaux d'emballage pour détecter les petites pièces qui pourraient s'être détachées à l'intérieur du carton pendant le transport. Identifiez et comptez tous les éléments conformément à la LISTE DES PIÈCES et/ou à la LISTE DU MATÉRIEL indiquée ci-dessous. Vérifiez que vous disposez de tous les composants et outils répertoriés dans les pages suivantes.

- Nous vous recommandons d'assembler ce produit avec l'aide d'une autre personne ; cela facilitera l'assemblage et aidera à éliminer les dommages au produit ou les blessures corporelles pendant l'assemblage.

- Veuillez ne pas trop serrer les vis ou les boulons jusqu'à ce que l'assemblage soit terminé.

- Tenir les enfants et les animaux éloignés de la zone de travail, les petites pièces pourraient s'étouffer en cas d'ingestion.

- Veuillez placer toutes les pièces sur un sol non abrasif avant l'assemblage et suivre les étapes d'assemblage pour assembler correctement et efficacement votre produit nouvellement acheté.

Si vous constatez des problèmes d'assemblage ou des pièces manquantes ou endommagées, veuillez contacter le vendeur.

Instructions d'assemblage du verrou à came

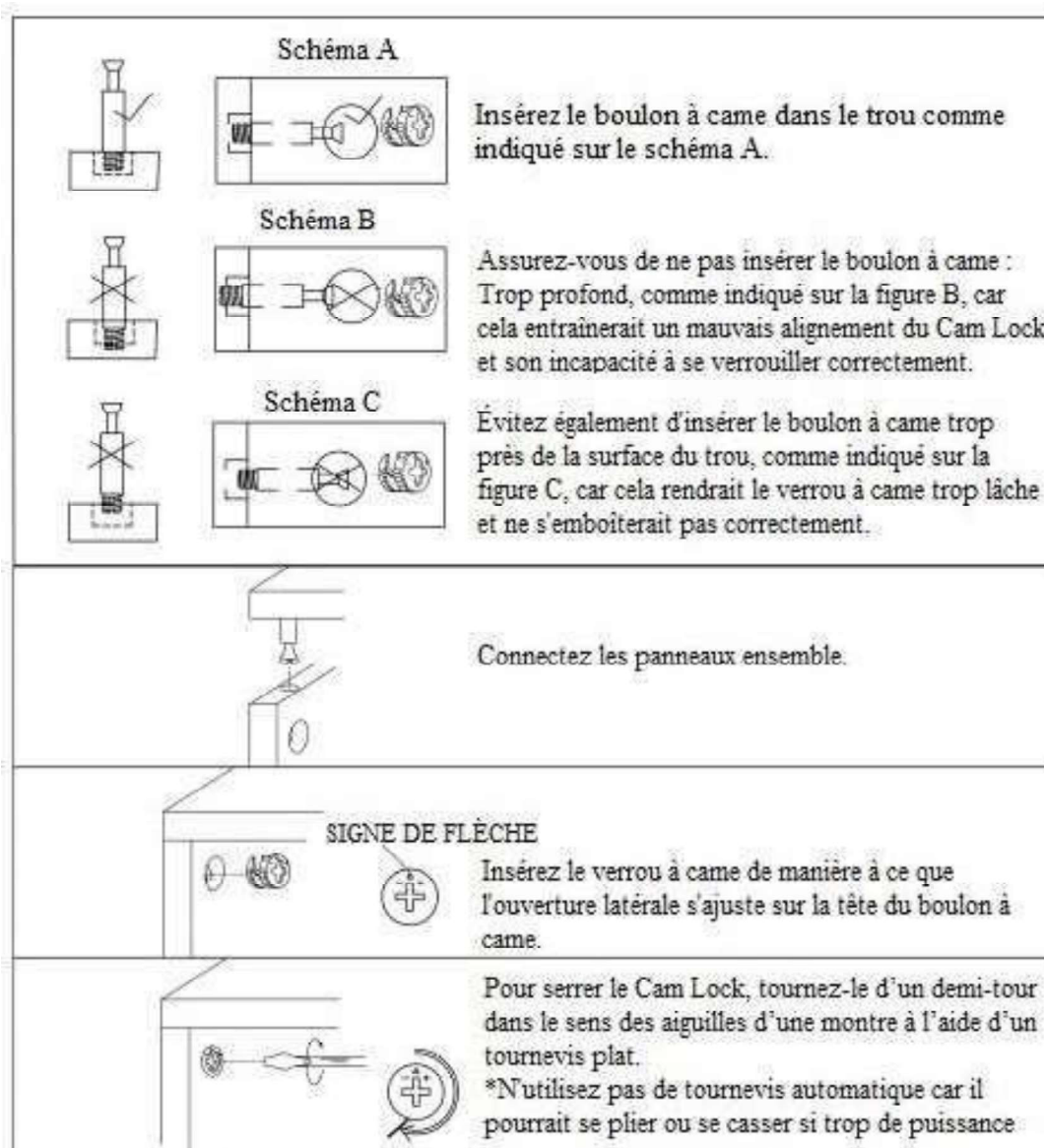



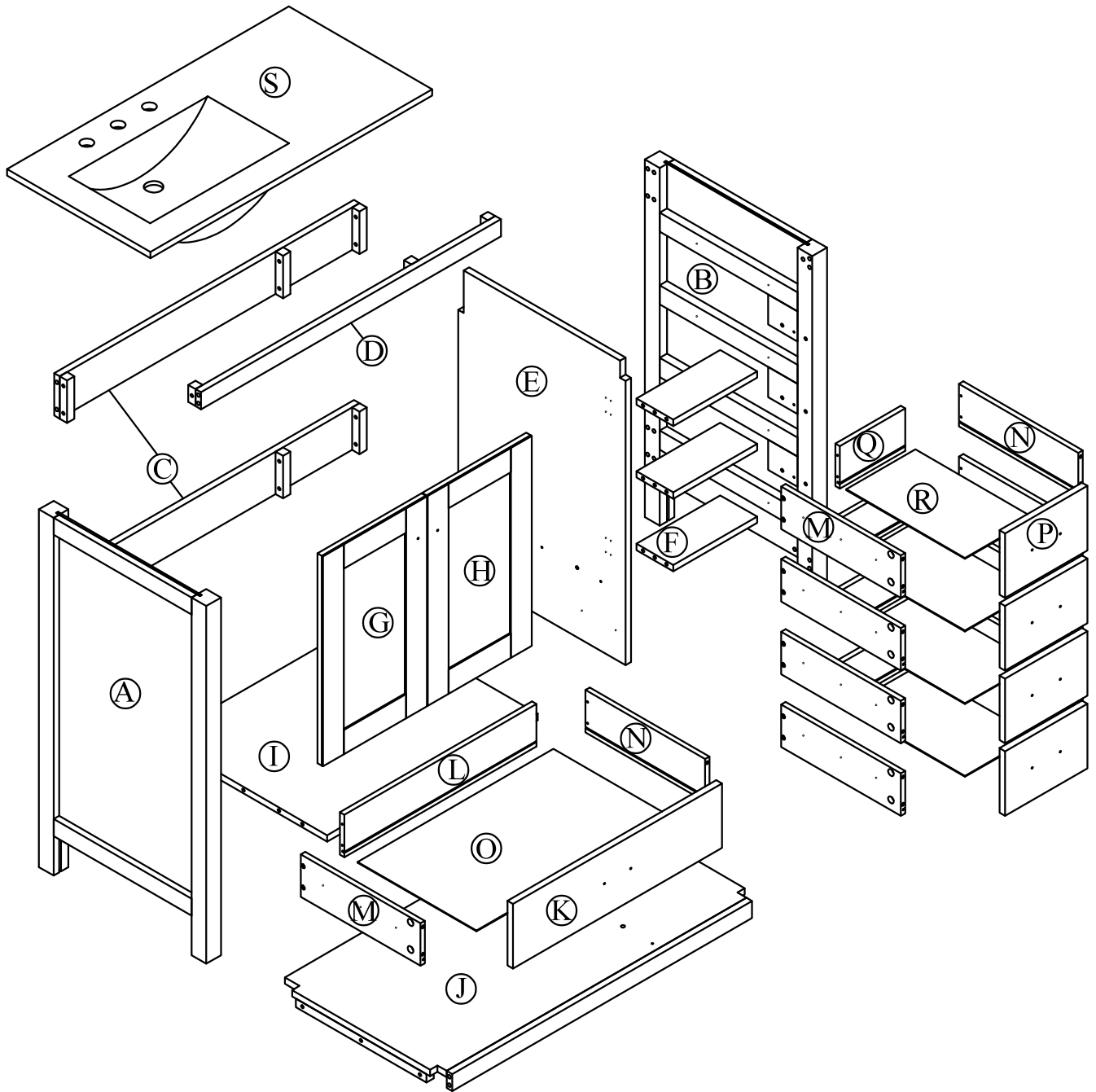

Detail View - VANITY
(Vue détaillée - Vanité)

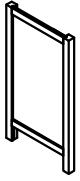
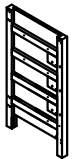
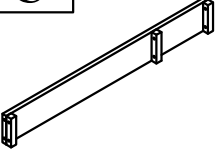
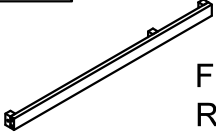

Identifying the Hardware - Identify the hardware using the illustrations below
(Identification du matériel - Identifiez le matériel à l'aide des illustrations ci-dessous)

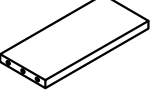
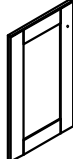
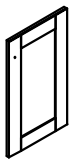
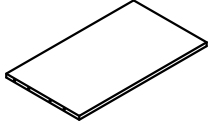

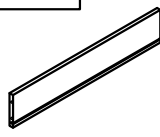
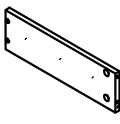
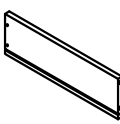
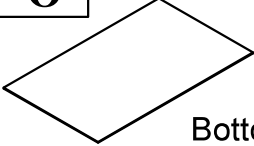
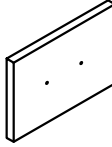



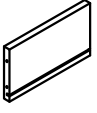
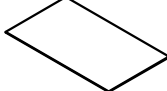
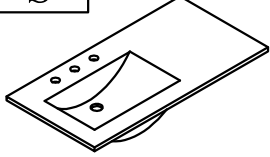



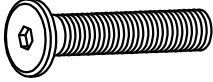
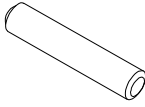
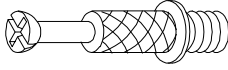
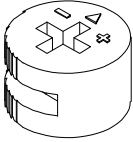
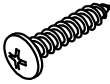
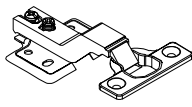

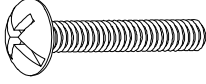

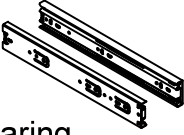



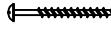

Part List (Liste des pièces)

<p>A</p>  <p>Side Panel (L) - 1PC Panneau latéral</p>	<p>B</p>  <p>Side Panel (R) - 1PC Panneau latéral</p>
<p>C</p>  <p>Back Panel - 2PCS Panneau arrière</p>	<p>D</p>  <p>Front Rail - 1PC Rail avant</p>
<p>E</p>  <p>Partition Panel - 1PC Panneau de séparation</p>	<p>F</p>  <p>Horizontal Partition - 3PCS Cloison Horizontale</p>
<p>G</p>  <p>Door (L) - 1PC Porte</p>	<p>H</p>  <p>Door (R) - 1PC Porte</p>
<p>I</p>  <p>Adjustable Shelf - 1PC Étagère réglable</p>	<p>J</p>  <p>Bottom frame - 1PC Cadre inférieur</p>
<p>K</p>  <p>Front Drawer Frame - 1PC Cadre avant du tiroir</p>	<p>L</p>  <p>Back Drawer Panel - 1PC Panneau arrière du tiroir</p>
<p>M</p>  <p>Side Drawer Panel (L) - 5PCS Panneau latéral du tiroir</p>	<p>N</p>  <p>Side Drawer Panel (R) - 5PCS Panneau latéral du tiroir</p>
<p>O</p>  <p>Bottom Drawer Panel - 1PC Panneau de tiroir inférieur</p>	<p>P</p>  <p>Front Drawer Frame - 4PCS Cadre avant du tiroir</p>

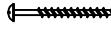
Part List (Liste des pièces)

Q  Back Drawer Panel - 4PCS Panneau arrière du tiroir	R  Bottom Drawer Panel - 4PCS Panneau de tiroir inférieur
S  Sink- 1PC Lavabo	

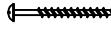
Part List (Liste des pièces)



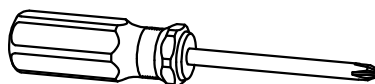

<p>1</p>  <p>Allen Bolts 1/4"x30 - 21PCS Boulons Allen</p>	<p>2</p>  <p>Wooden Ø8 x 30 - 30 PCS Enbois</p>	<p>3</p>  <p>Cam Lock Screws - 32PCS Vis de verrouillage à came</p>						
<p>4</p>  <p>Cam Lock -32PCS Serrure à came</p>	<p>5</p>  <p>Screws M4x30 - 23PCS Vis</p>	<p>6</p>  <p>Hinges - 4PCS Charnières</p>						
<p>7</p>  <p>Screws M4x15 - 24CS Vis</p>	<p>8</p>  <p>Screws M4x20 - 12PCS boulons à tête de vis</p>	<p>9</p>  <p>Allen key M4 - 1PC Clé Allen</p>						
<p>10</p>  <p>Ball Bearing Soft Close - 5 SET</p>	<p>11</p>  <p>Handle - 5PCS Poignée</p>	<p>12</p>  <p>Handle - 2PCS Poignée</p>						
<p>13</p>  <p>Screws M3.5x12 - 60PCS Vis</p>	<p>Hardware list: (Anti tipping kit 2 set in the bag)</p> <table border="1"> <tr> <td data-bbox="596 1375 810 1451"> <p>A</p>  <p>Brackets - 04pcs</p> </td> <td data-bbox="815 1375 1029 1451"> <p>B</p>  <p>Steel cables - 02pcs</p> </td> </tr> <tr> <td data-bbox="596 1458 810 1534"> <p>C</p>  <p>Screws - 02pcs</p> </td> <td data-bbox="815 1458 1029 1534"> <p>D</p>  <p>Screws - 02pcs</p> </td> </tr> <tr> <td data-bbox="596 1541 810 1599"> <p>E</p>  <p>wall anchor - 02pcs</p> </td> <td data-bbox="815 1541 1029 1599"></td> </tr> </table>		<p>A</p>  <p>Brackets - 04pcs</p>	<p>B</p>  <p>Steel cables - 02pcs</p>	<p>C</p>  <p>Screws - 02pcs</p>	<p>D</p>  <p>Screws - 02pcs</p>	<p>E</p>  <p>wall anchor - 02pcs</p>	
<p>A</p>  <p>Brackets - 04pcs</p>	<p>B</p>  <p>Steel cables - 02pcs</p>							
<p>C</p>  <p>Screws - 02pcs</p>	<p>D</p>  <p>Screws - 02pcs</p>							
<p>E</p>  <p>wall anchor - 02pcs</p>								

ASSEMBLY TOOLS REQUIRED (NOT INCLUDED)



STEP: 1

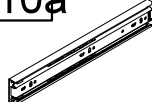

(ÉTAPE : 1)

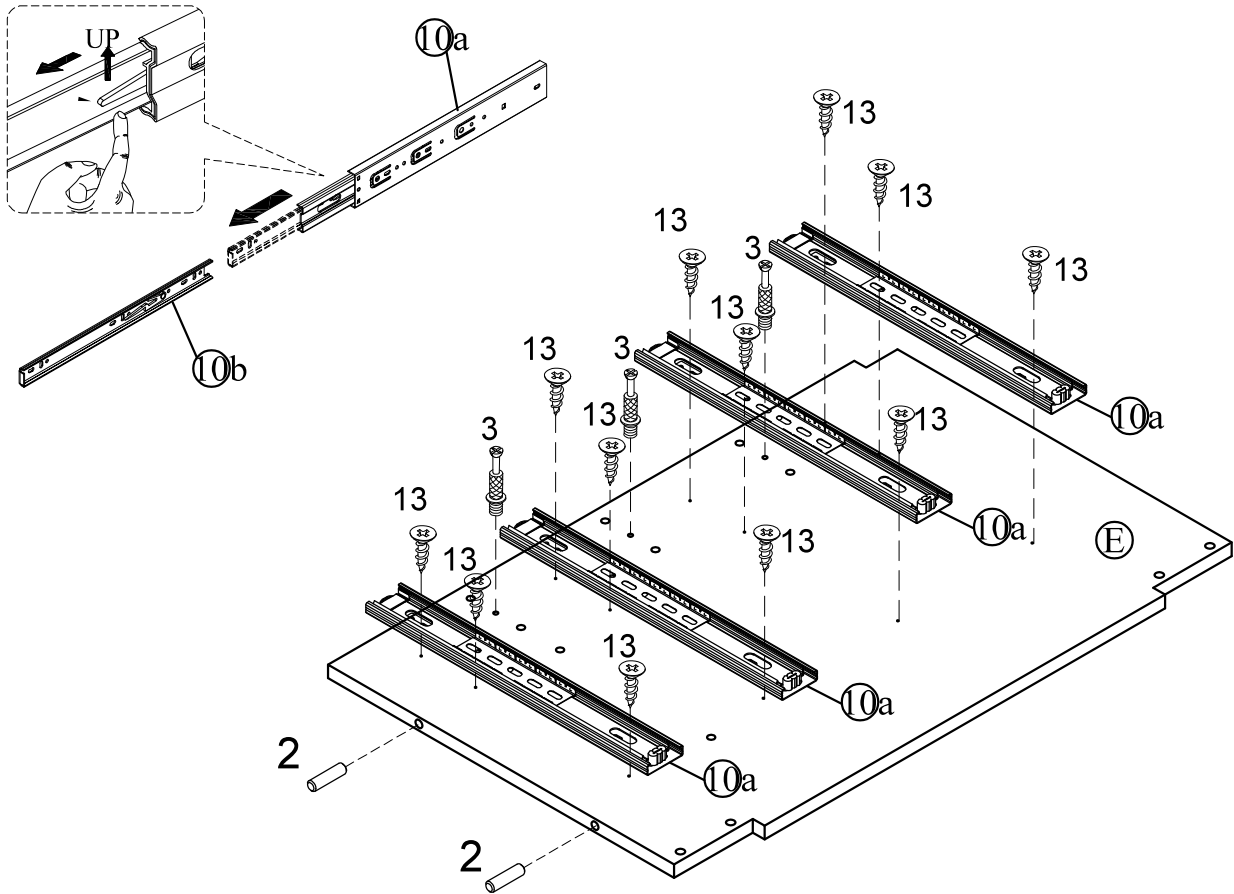
3	2	10a	13
			
3 PCS	2 PCS	04 PCS	12 PCS

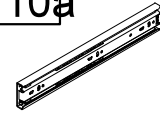

STEP: 2

(ÉTAPE : 2)

3	10a	13
		
3 PCS	1 PC	3 PCS

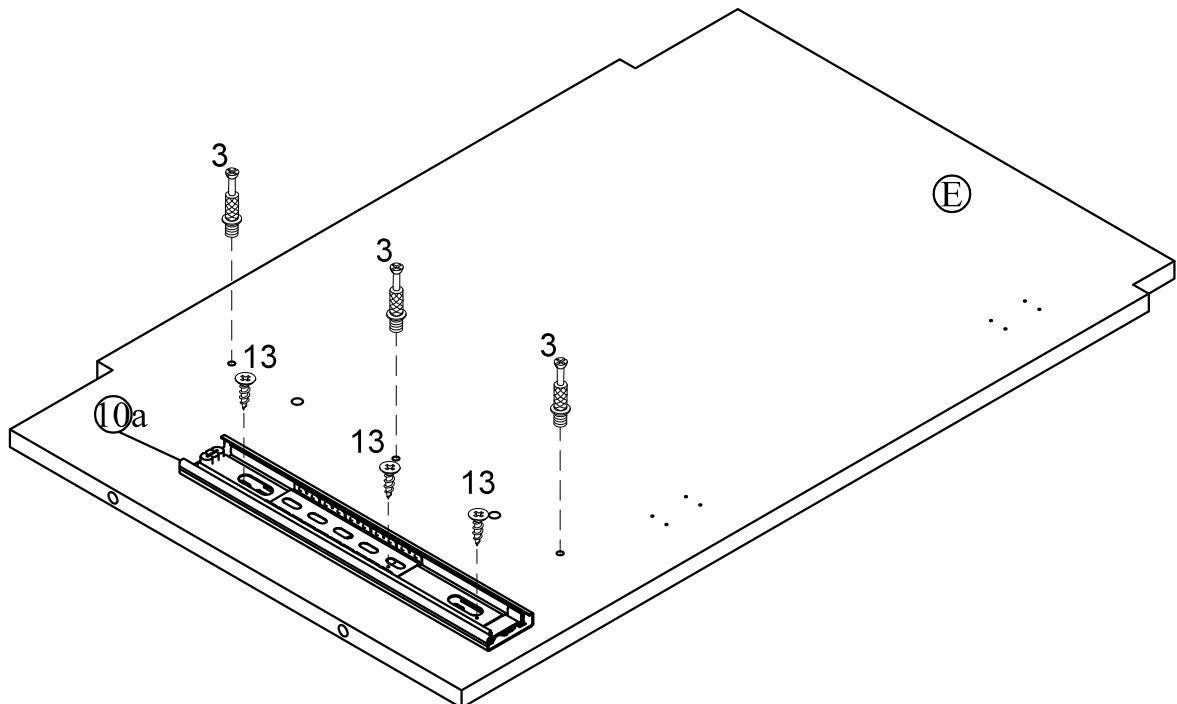

STEP: 3

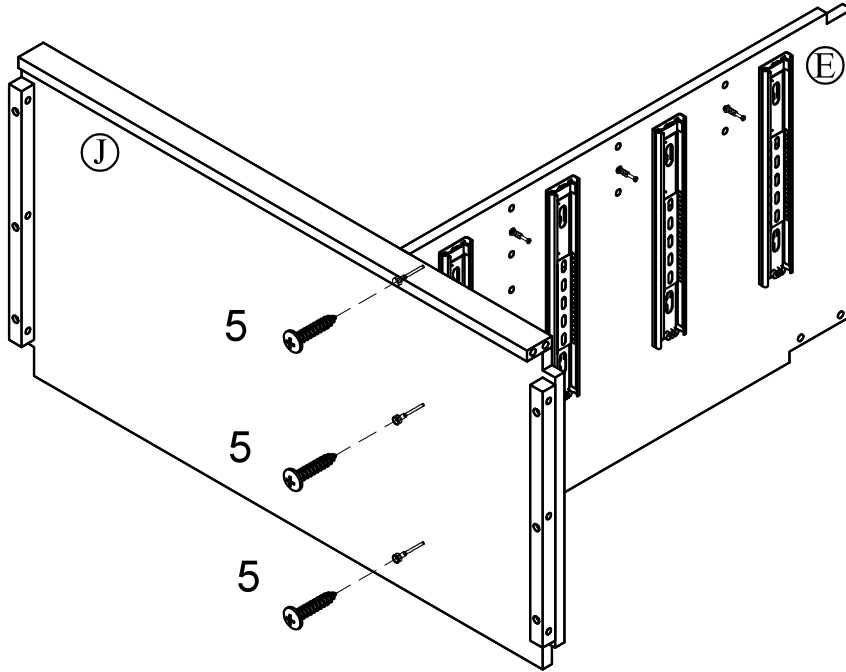

(ÉTAPE : 3)

5	
M4 X 30	
3 PCS	



STEP: 4

(ÉTAPE : 4)

2		9		1	
Ø8 X 30		Allen key M4		1/4 X 30	
6 PCS		1 PC		5 PCS	

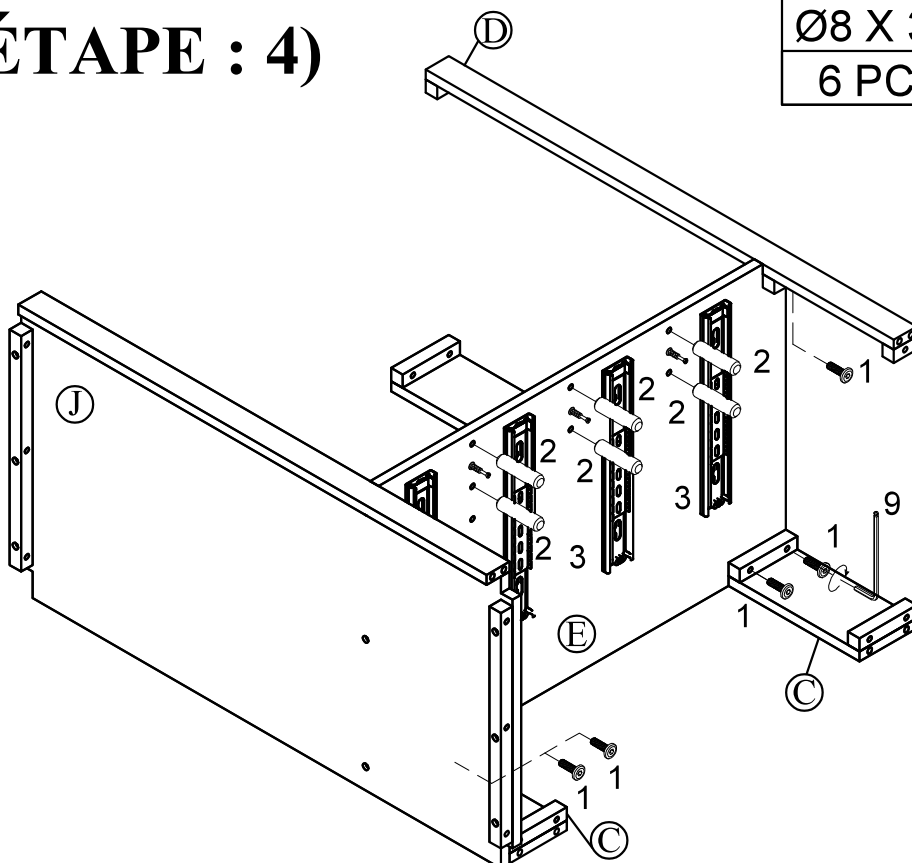

STEP: 5

(ÉTAPE : 5)

2
Ø8 X 30
2 PCS

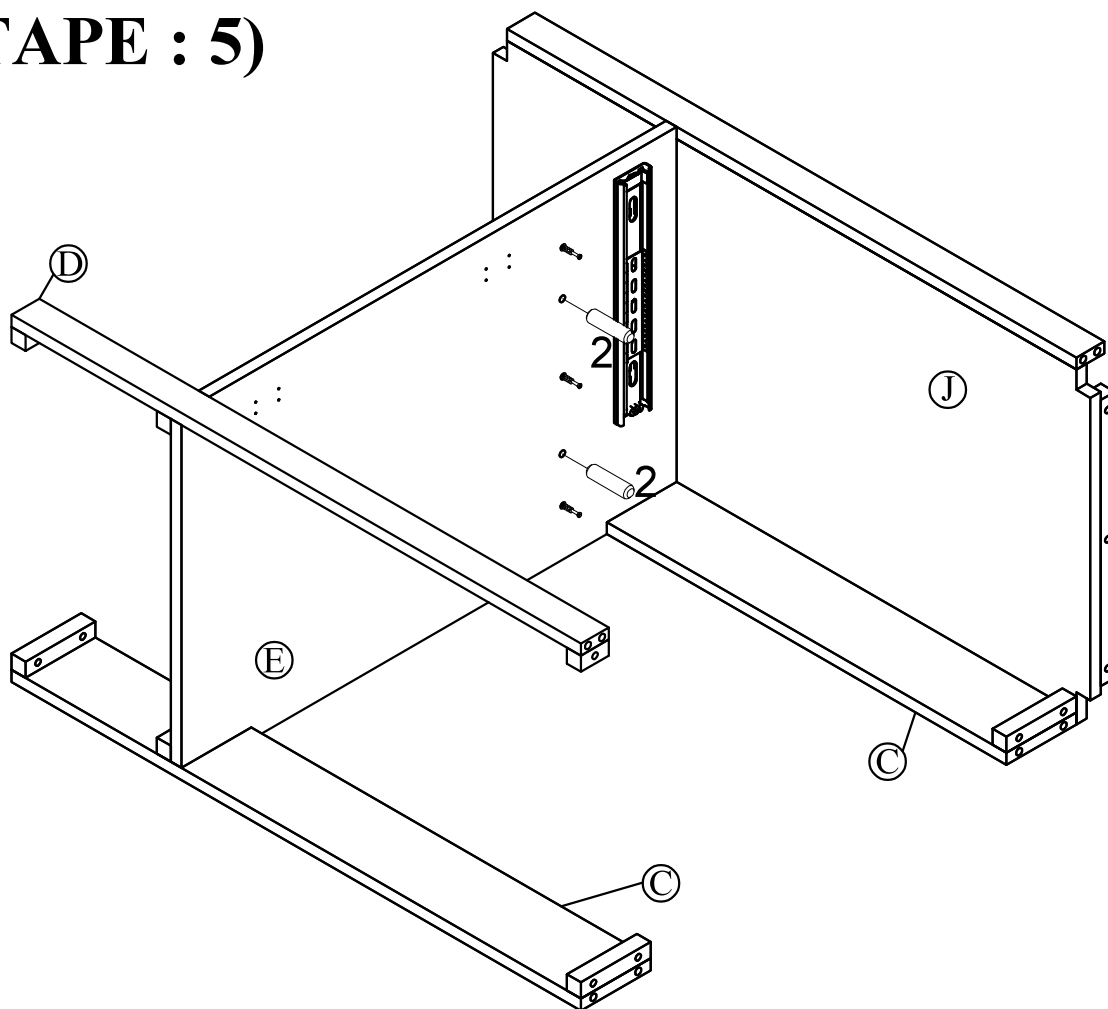

STEP: 6



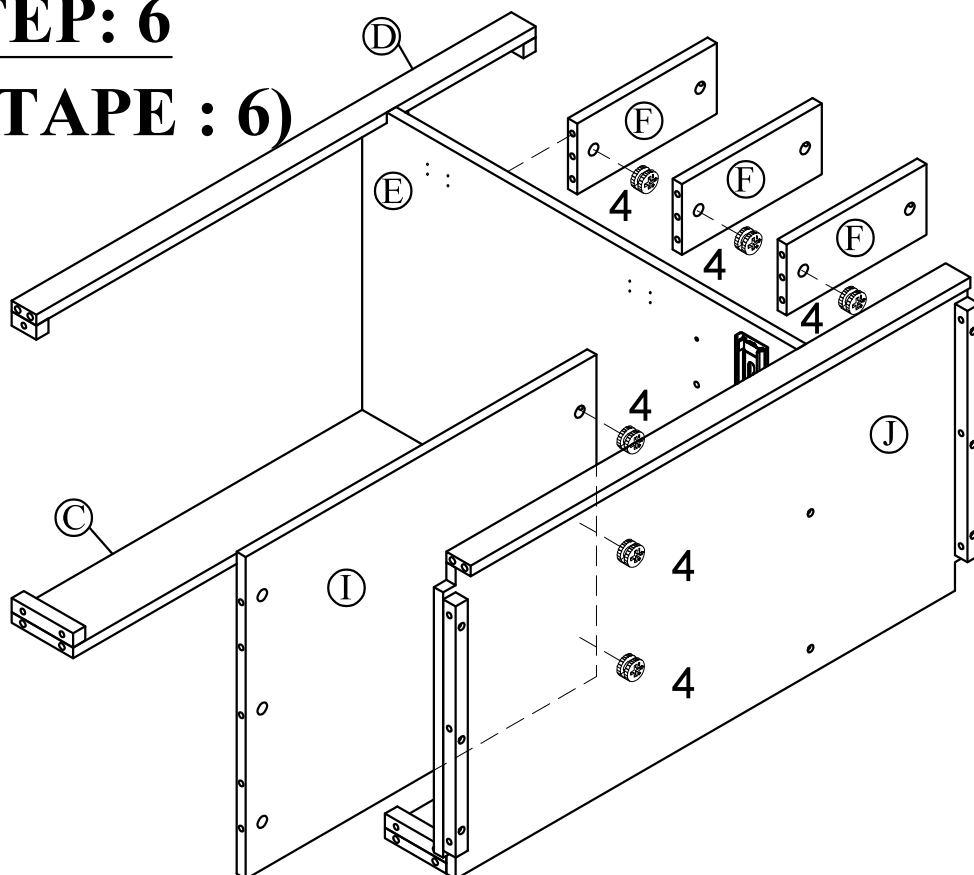

(ÉTAPE : 6)

4
6 PCS



STEP: 7

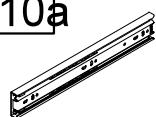

(ÉTAPE : 7)

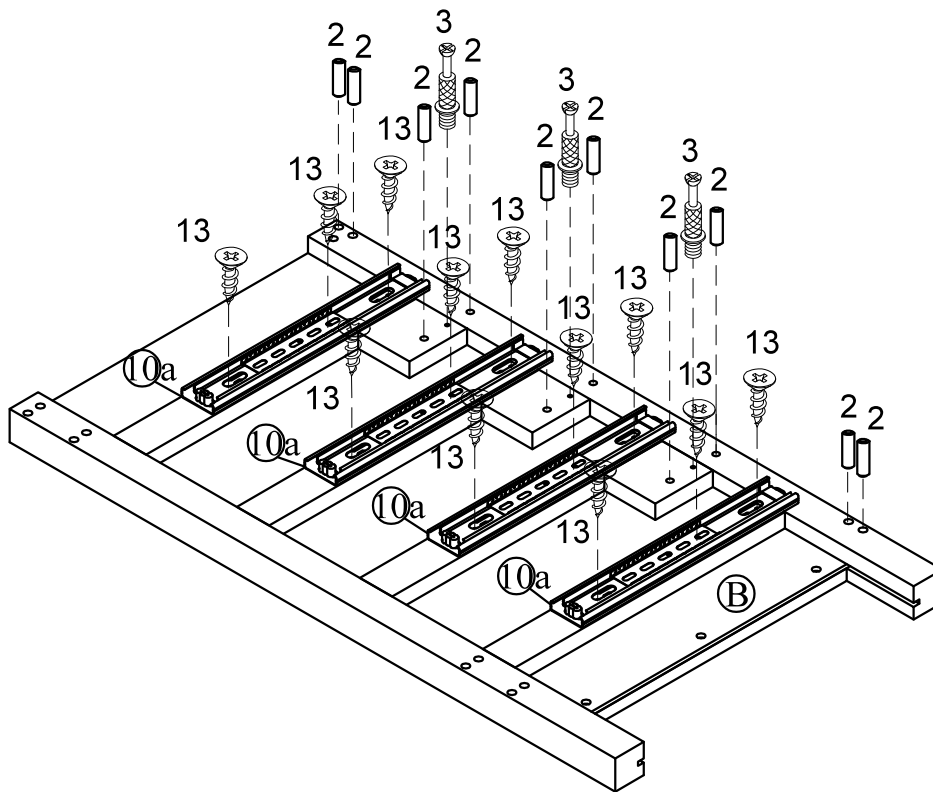
3	2	10a	13
			
3 PCS	Ø8 X 30 10 PCS	04 PCS	M3.5 X 12 12 PCS



STEP: 8



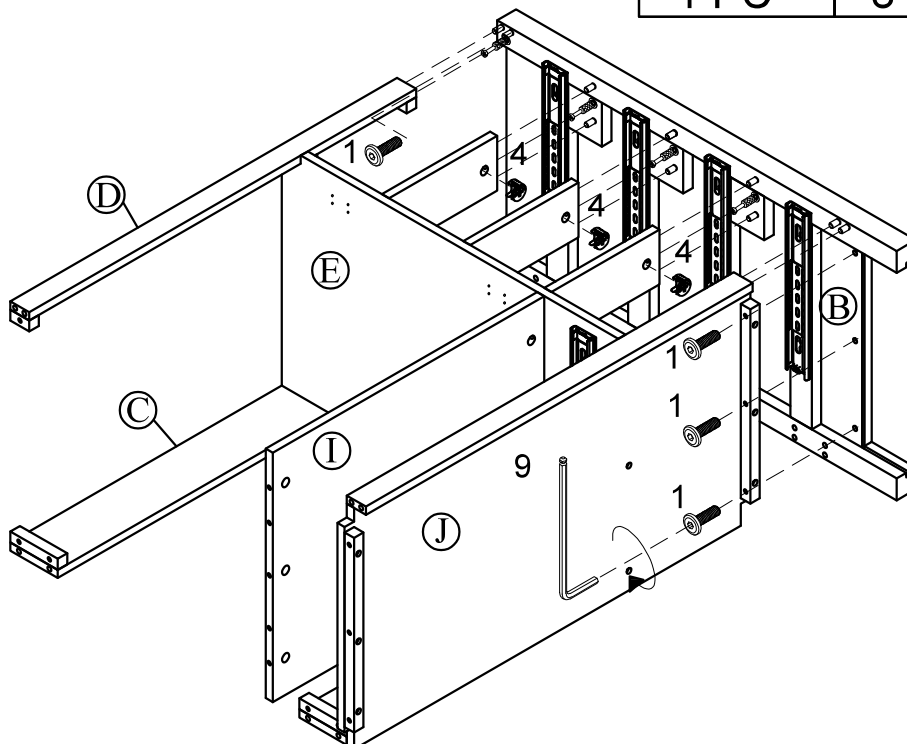

(ÉTAPE : 8)

9	1	4
		
Allen key M4 1 PC	1/4 X 30 8 PCS	3 PCS



STEP: 9

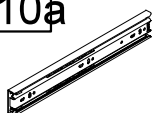

(ÉTAPE : 9)

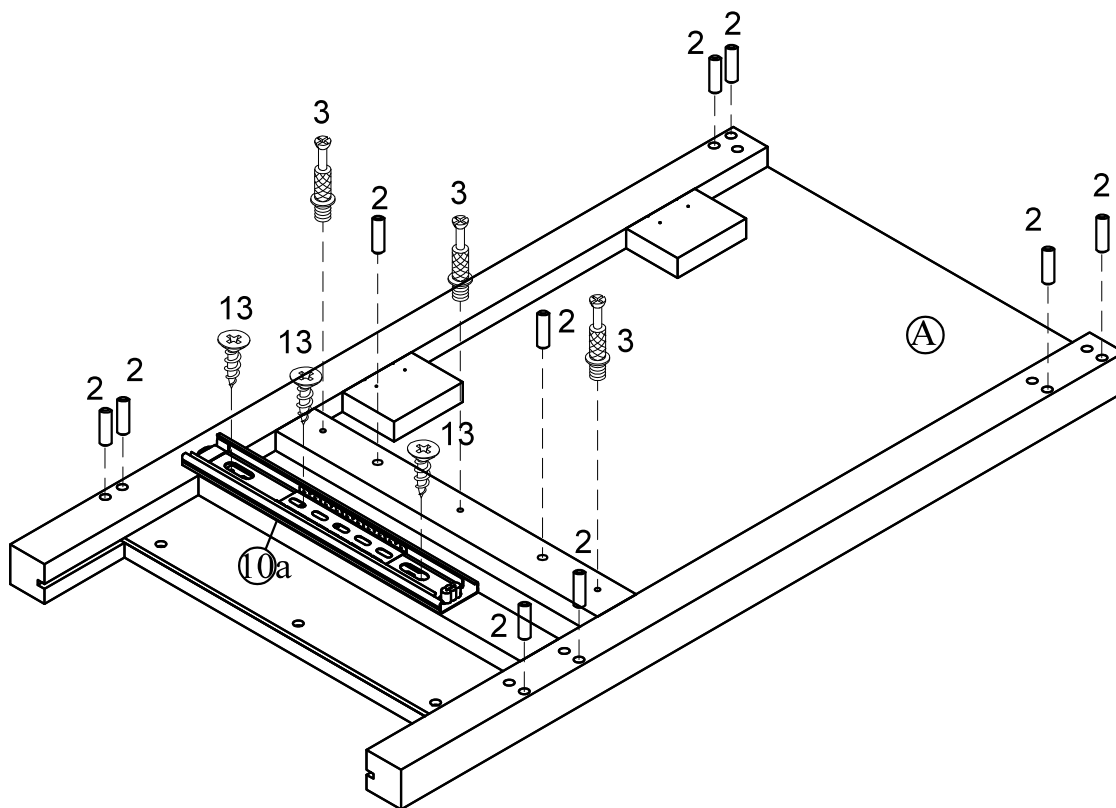
3	2	10a	13
			
Ø8 X 30			M3.5 X 12
3 PCS	10 PCS	01 PC	3 PCS



STEP: 10

(ÉTAPE : 10)

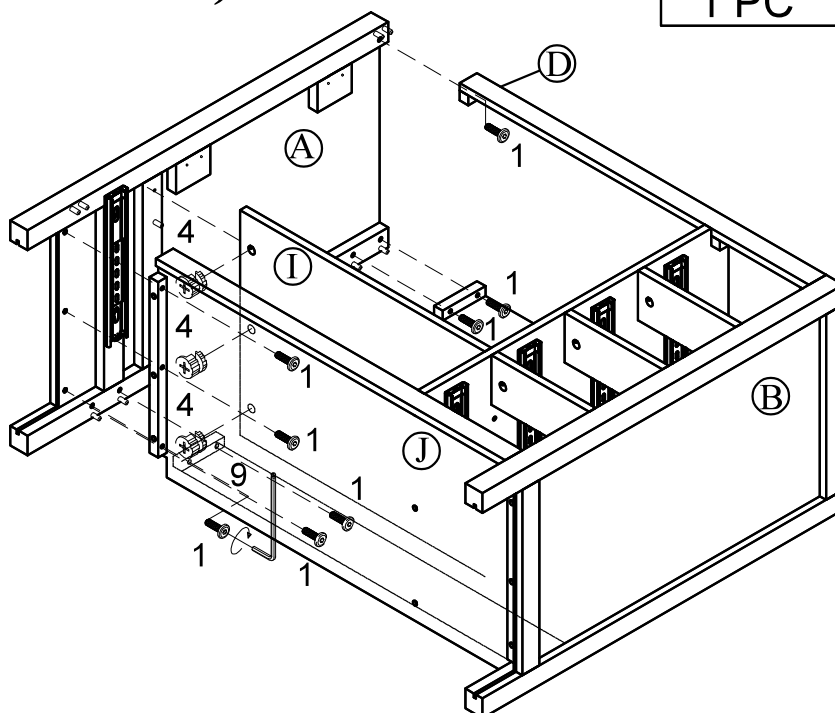

9	1	4
		
Allen key M4	1/4 X 30	
1 PC	8 PCS	3 PCS

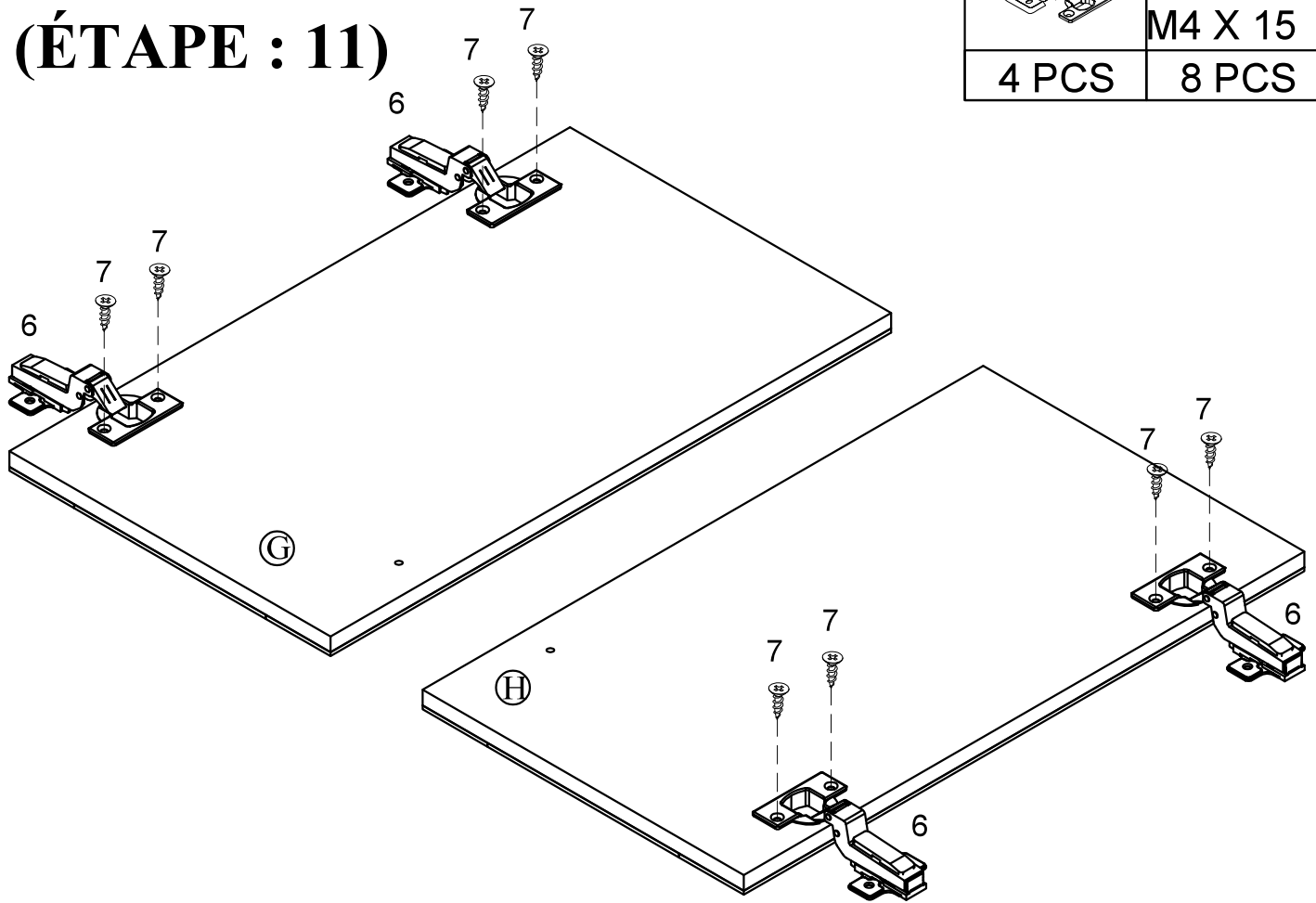

STEP: 11

(ÉTAPE : 11)





6	7
	
4 PCS	M4 X 15 8 PCS

STEP: 12

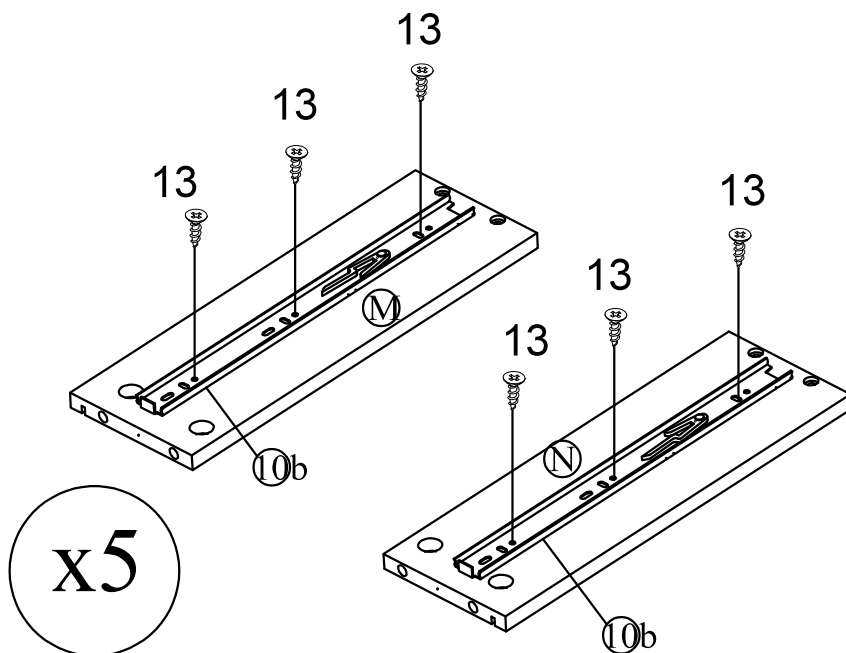
(ÉTAPE : 12)



x5

10b	13
	
10 PCS	M3.5 X 12 30 PCS

STEP: 13

(ÉTAPE : 13)

3



20 PCS

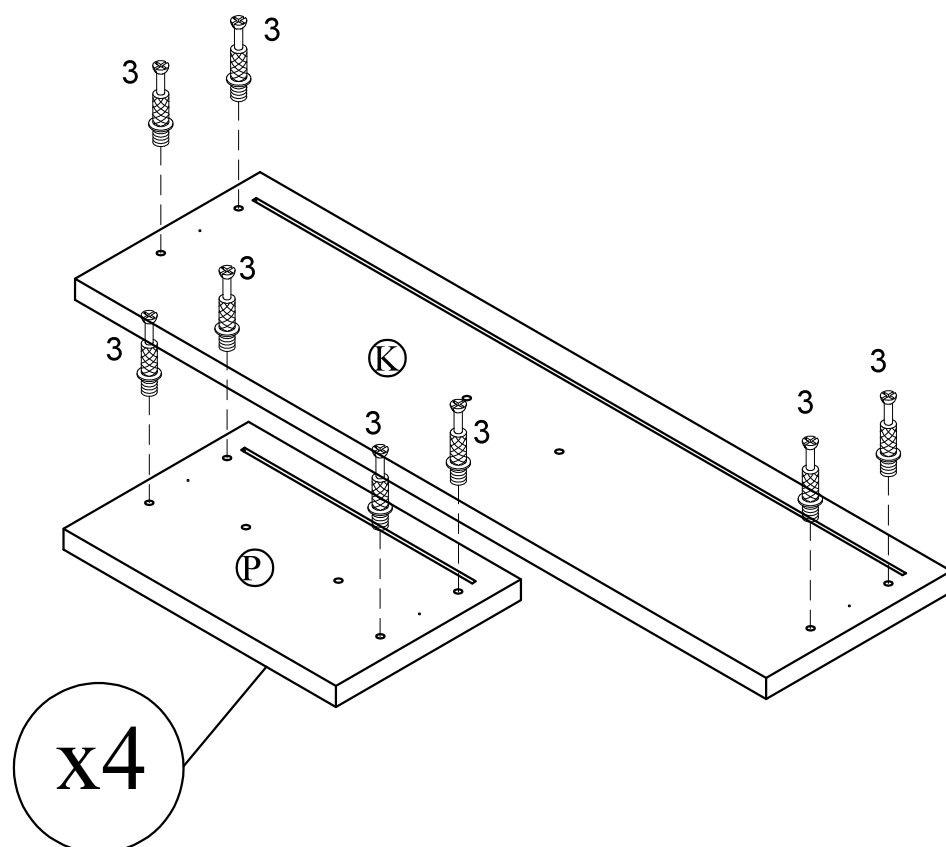

STEP: 14

(ÉTAPE : 14)

4



20 PCS

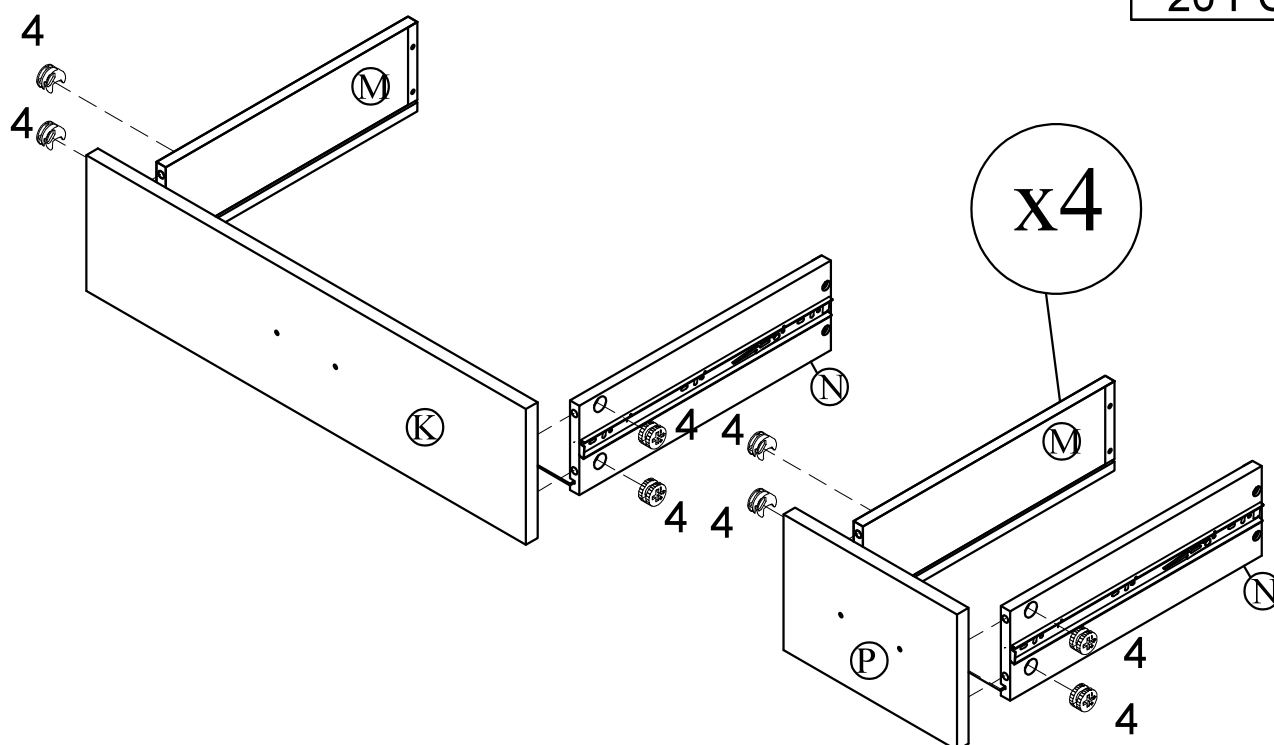

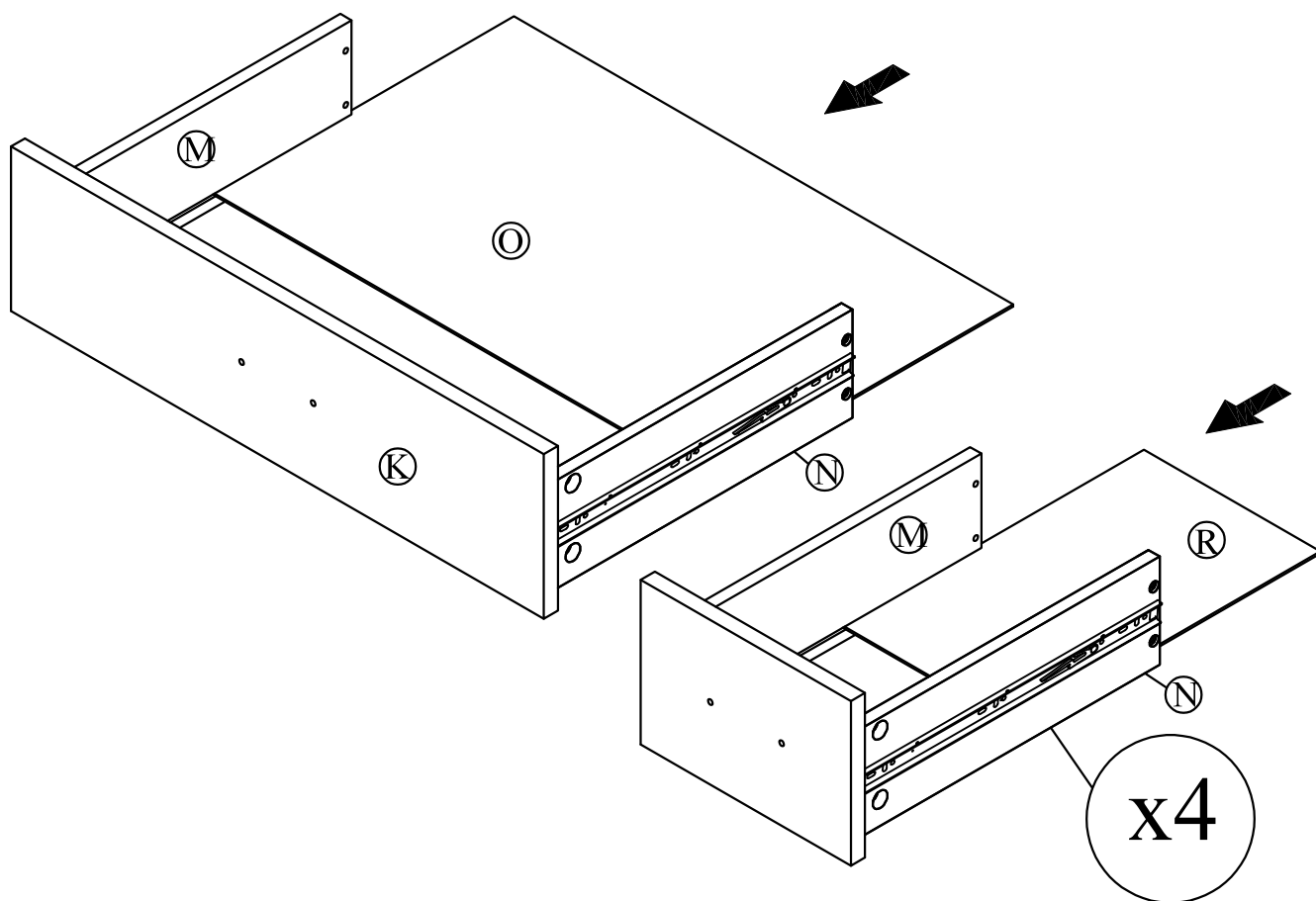

STEP: 15

(ÉTAPE : 15)



STEP: 16

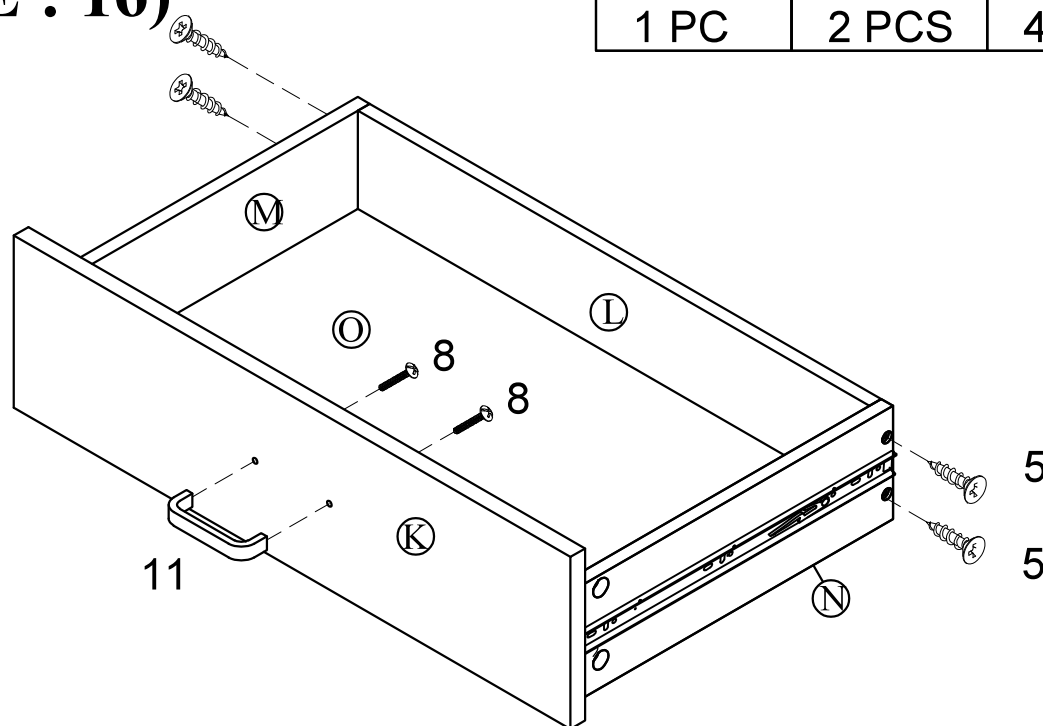

(ÉTAPE : 16)

11		8		5	
			M4 X 20		M4 X 30
	1 PC		2 PCS		4 PCS



STEP: 17

(ÉTAPE : 17)

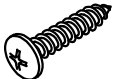
11		8		5	
			M4 X20		M4 X 30
	4 PCS		8 PCS		16 PCS

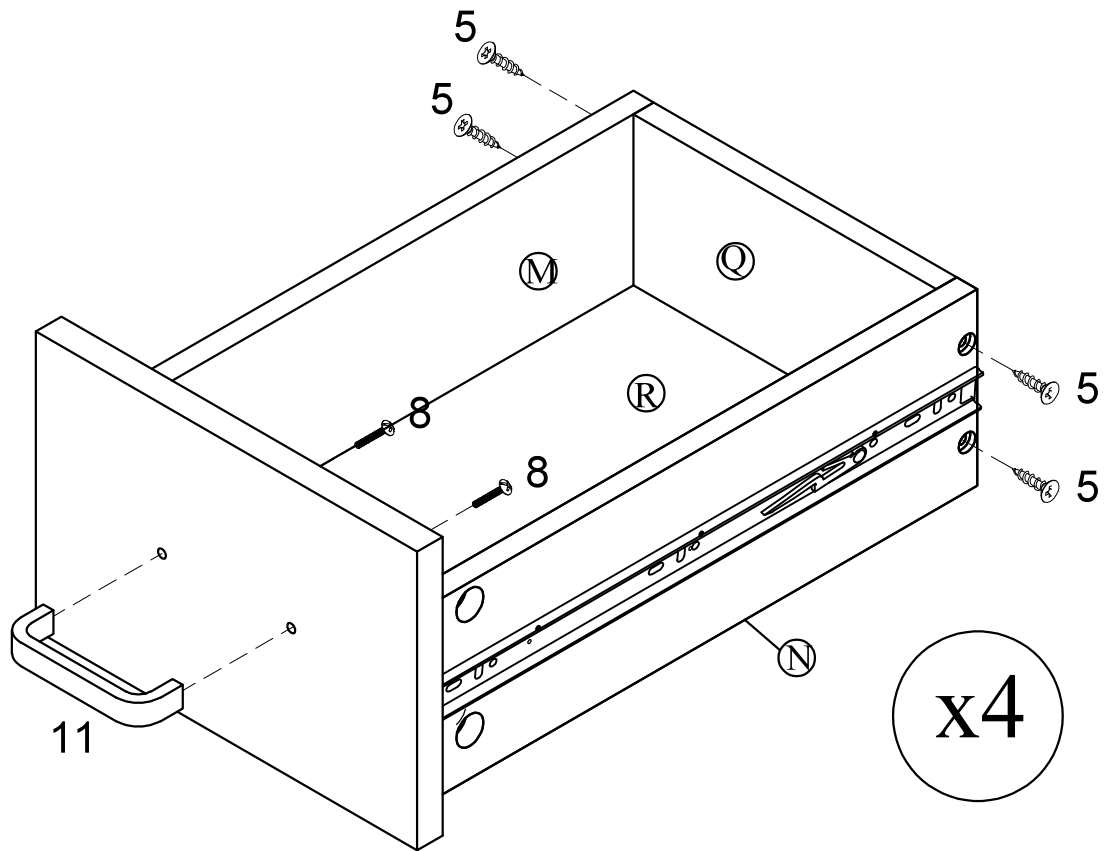



STEP: 18

(ÉTAPE : 18)

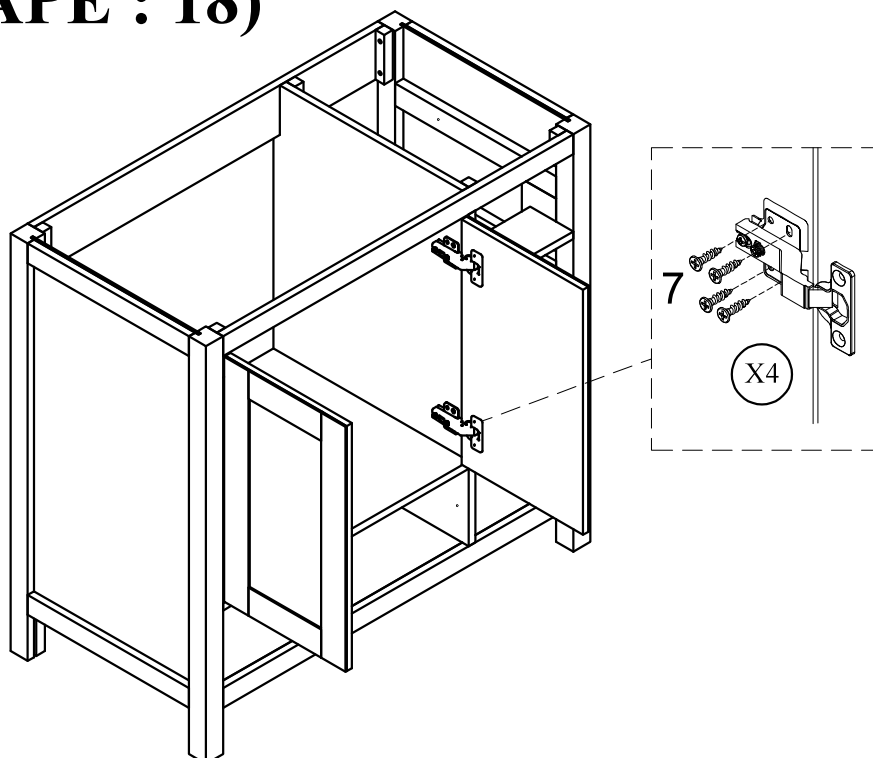
7	
	M4 X 15
	16 PCS

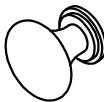

STEP: 19
(ÉTAPE : 19)

12		8	
2 PCS		M4 X20	
2 PCS		2 PCS	

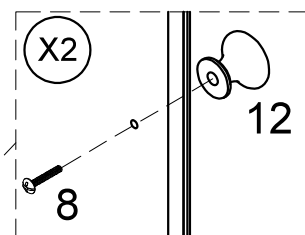
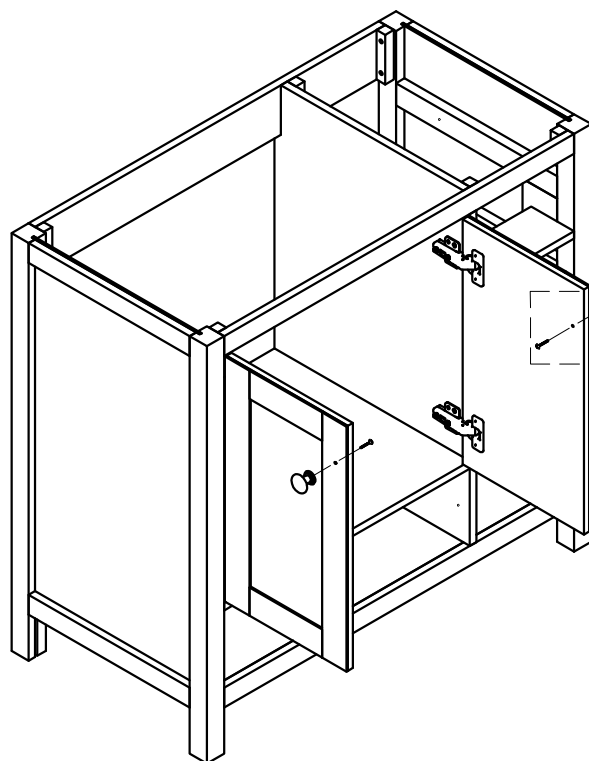

STEP: 20
(ÉTAPE : 20)

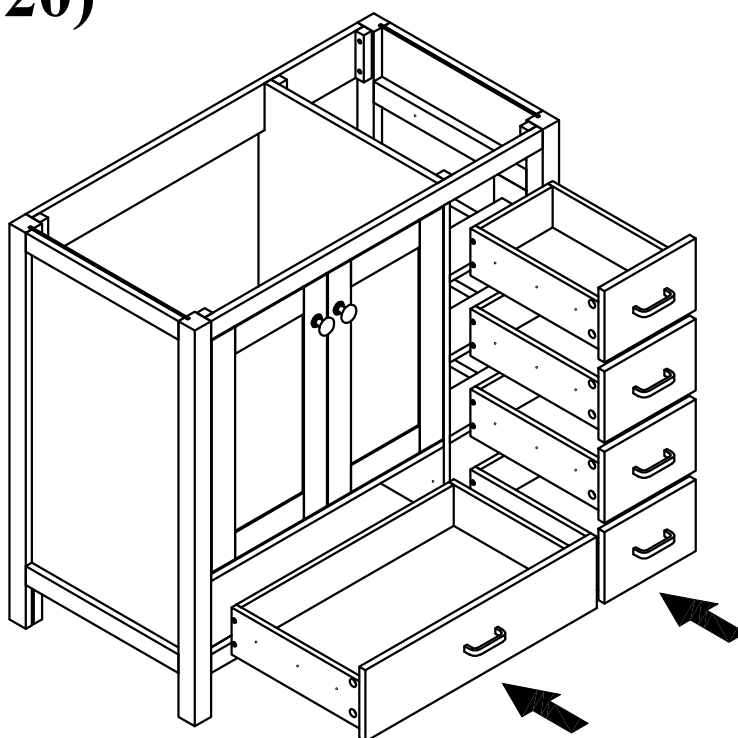

STEP: 21

(ÉTAPE : 21)

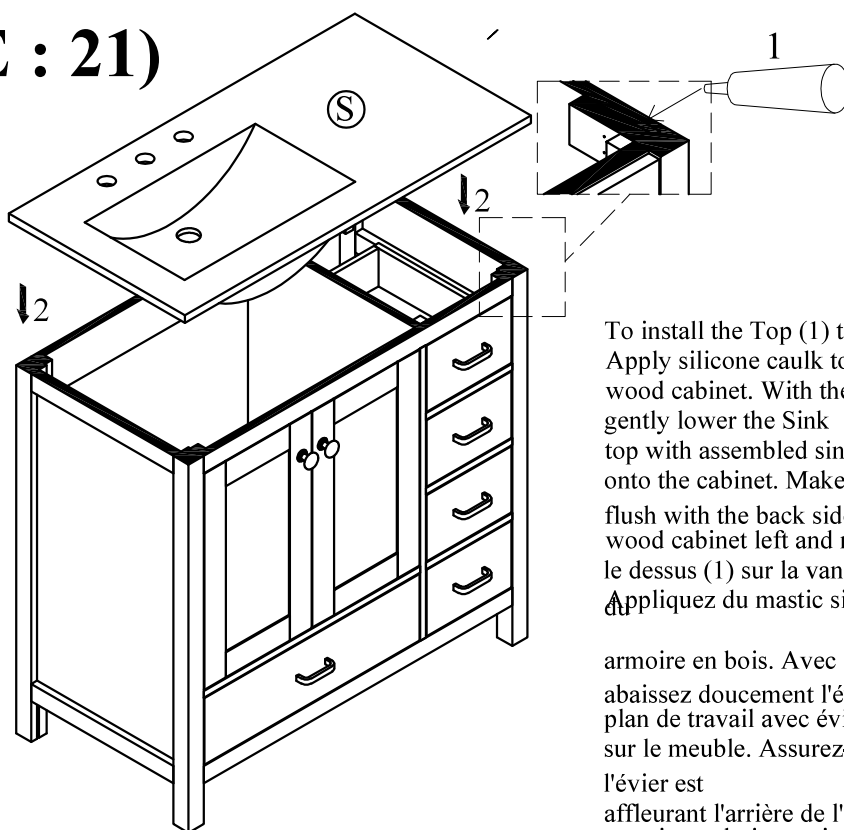



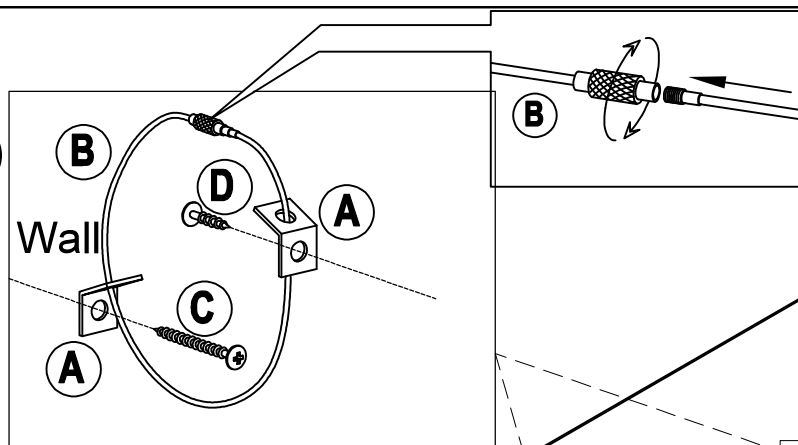

To install the Top (1) to the vanity (2). Apply silicone caulk to the top edge of the wood cabinet. With the help of another adult, gently lower the Sink top with assembled sink onto the cabinet. Make sure the Sink top is flush with the back side of the wood cabinet and the wood cabinet left and right side walls. Pour installer le dessus (1) sur la vanité (2). Appliquez du mastic silicone sur le bord supérieur armoire en bois. Avec l'aide d'un autre adulte, abaissez doucement l'évier plan de travail avec évier assemblé sur le meuble. Assurez-vous que le dessus de l'évier est affleurant l'arrière de l'armoire en bois et le armoire en bois parois latérales gauche et droite.

STEP: 22

(ÉTAPE : 22)

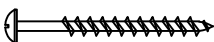
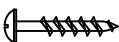

Hardware list: (Anti tipping kit 2 set in the bag)

A  Brackets - 04pcs	B  Steel cables - 02pcs
C  Screws - 02pcs	D  Screws - 02pcs
E  wall anchor - 02pcs	

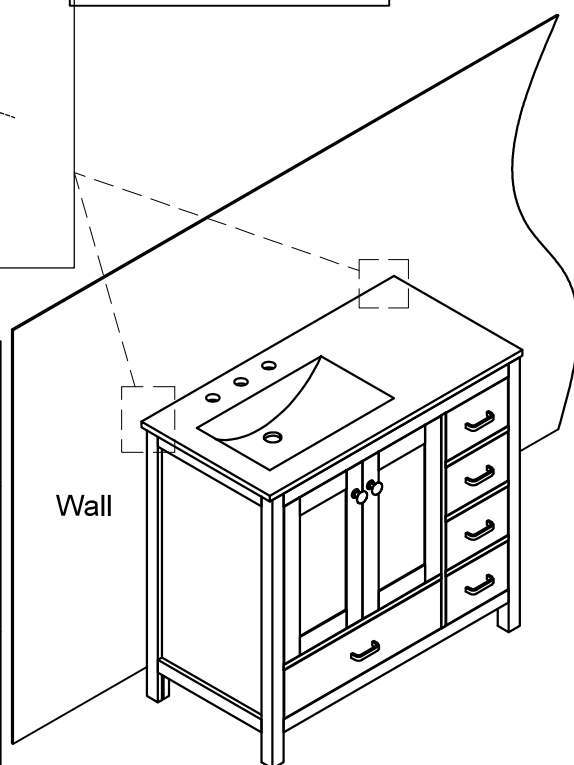

HINGE ADJUSTMENTS

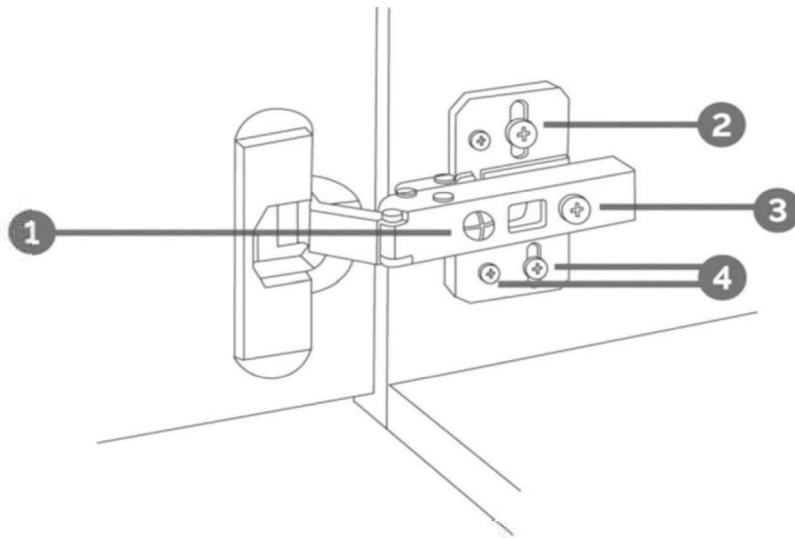

1 Sideways / Tilt adjustment

Turn the screw
clockwise to move the door further away from the side of the cabinet
anticlockwise to move the door closer to the side of the cabinet

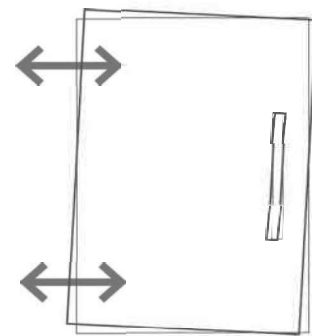

2 4 Height adjustment

While supporting the weight of the door, turn the screws
clockwise to move the door up
anticlockwise to move the door down

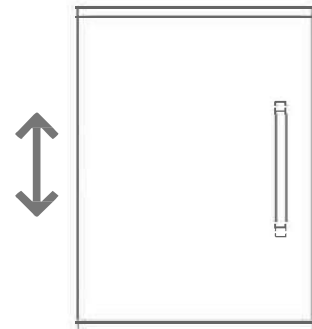

3 Forward and back adjustment

If the gap between the back of the door and the cabinet is too small, and the door may not close fully. Turn the screw
clockwise to decrease the gap between the door and the cabinet
anticlockwise to increase the gap between the door and the cabinet

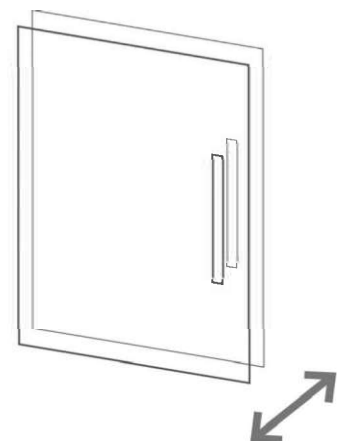

RÉGLAGES DES CHARNIÈRES

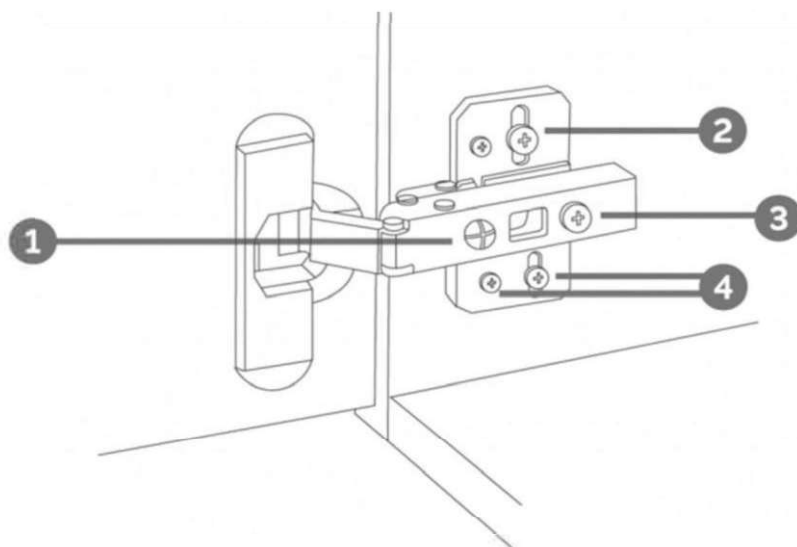

① De côté / Réglage de l'inclinaison

Tournez la vis dans le sens des aiguilles d'une montre pour éloigner la porte le côté du meuble
dans le sens inverse des aiguilles d'une montre pour rapprocher la porte du côté du meuble

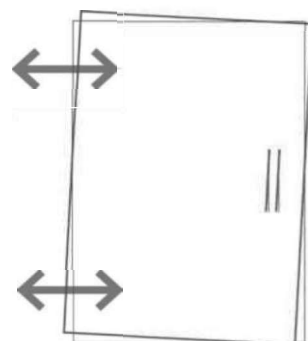

② ④ Réglage de la

Tout en supportant le poids de la porte, tournez les vis dans le sens des aiguilles d'une montre pour déplacer la porte vers le haut
dans le sens inverse des aiguilles d'une montre pour abaisser la porte



③ Réglage vers l'avant et vers l'arrière

Si l'espace entre l'arrière de la porte et le l'armoire est trop petite et la porte risque de ne pas se fermer complètement. Tournez la vis dans le sens des aiguilles d'une montre pour diminuer l'écart entre la porte et l'armoire
dans le sens inverse des aiguilles d'une montre pour augmenter l'écart entre la porte et l'armoire.

