

ASSEMBLY INSTRUCTIONS

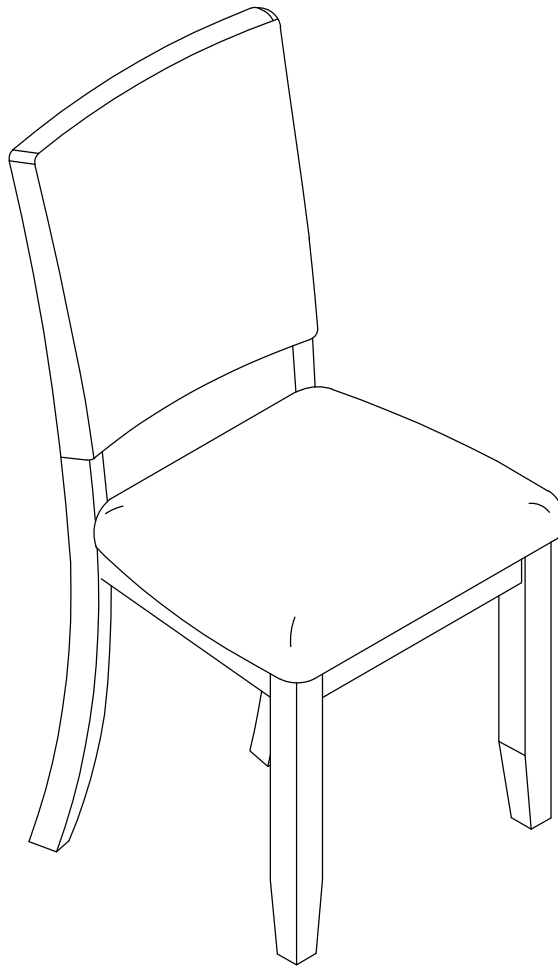

ITEM NO. FB3056HAY-SC-4PK





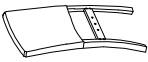
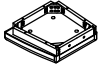

ASSEMBLY TIPS:

1. Remove hardware from box and sort by size.
2. Please check to see that all hardware and parts are present prior to start of assembly.
3. Please follow attached instructions in the same sequence as numbered to assure fast & easy assembly.

Part List

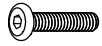
NO.	DIAGRAM	PART NAME	Q'ty
#1		Back frame with cushion	1pc x4
#2		Seat frame with cushion	1pc x4
#3		Front Legs	2pcs x4

Part List

NO.	DIAGRAM	PART NAME	Q'ty
#A		Bolt Ø1/4" x 3"	4pcs x4
#B		Bolt Ø1/4" x 2-3/8"	4pcs x4
#C		Bolt Ø1/4" x 1-1/2"	2pcs x4
#D		Spring washer Ø1/4"	10pcs x4
#E		Flat washer Ø1/4"	10pcs x4
#F		Allen key M4	1pc x4

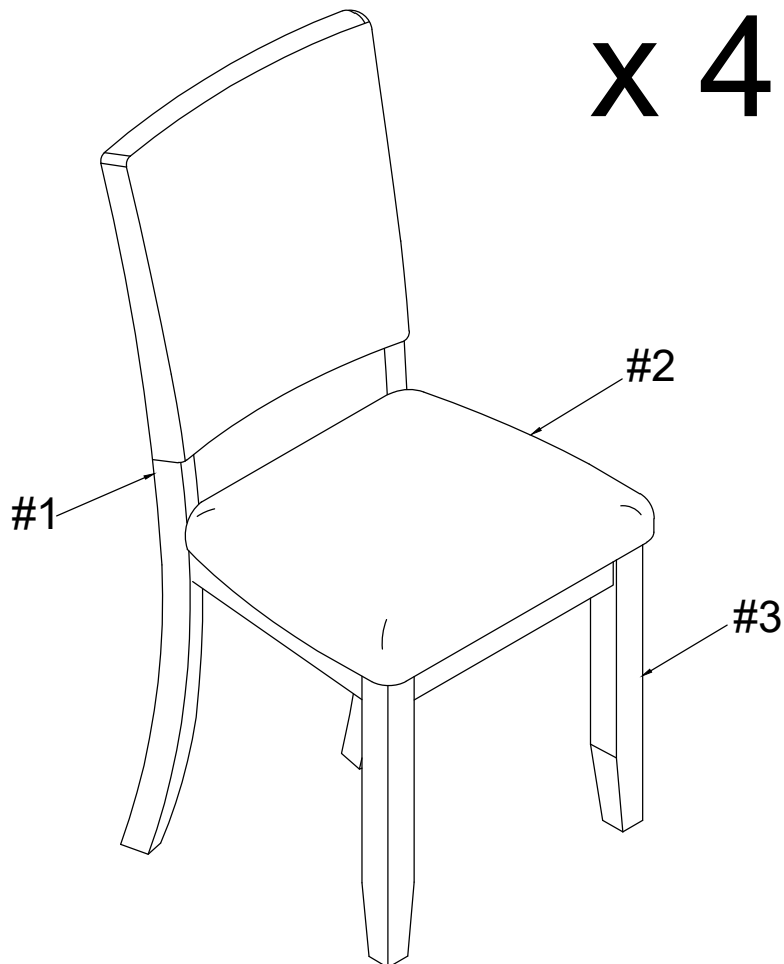

STEP 1

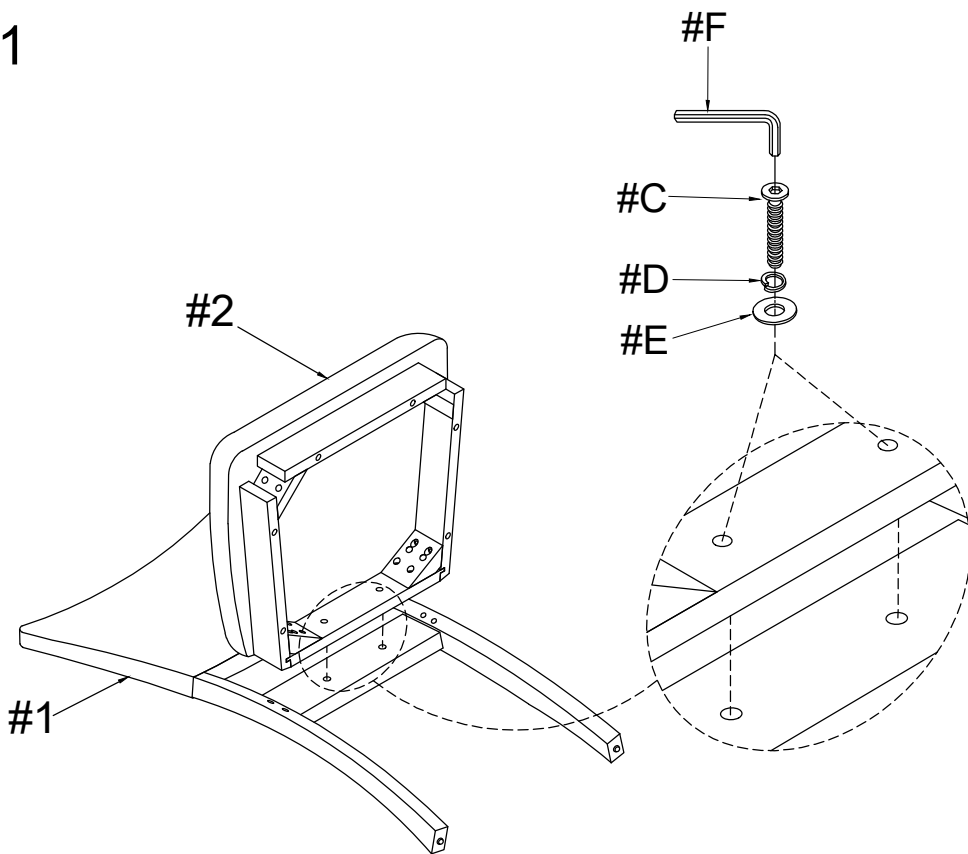

STEP 2

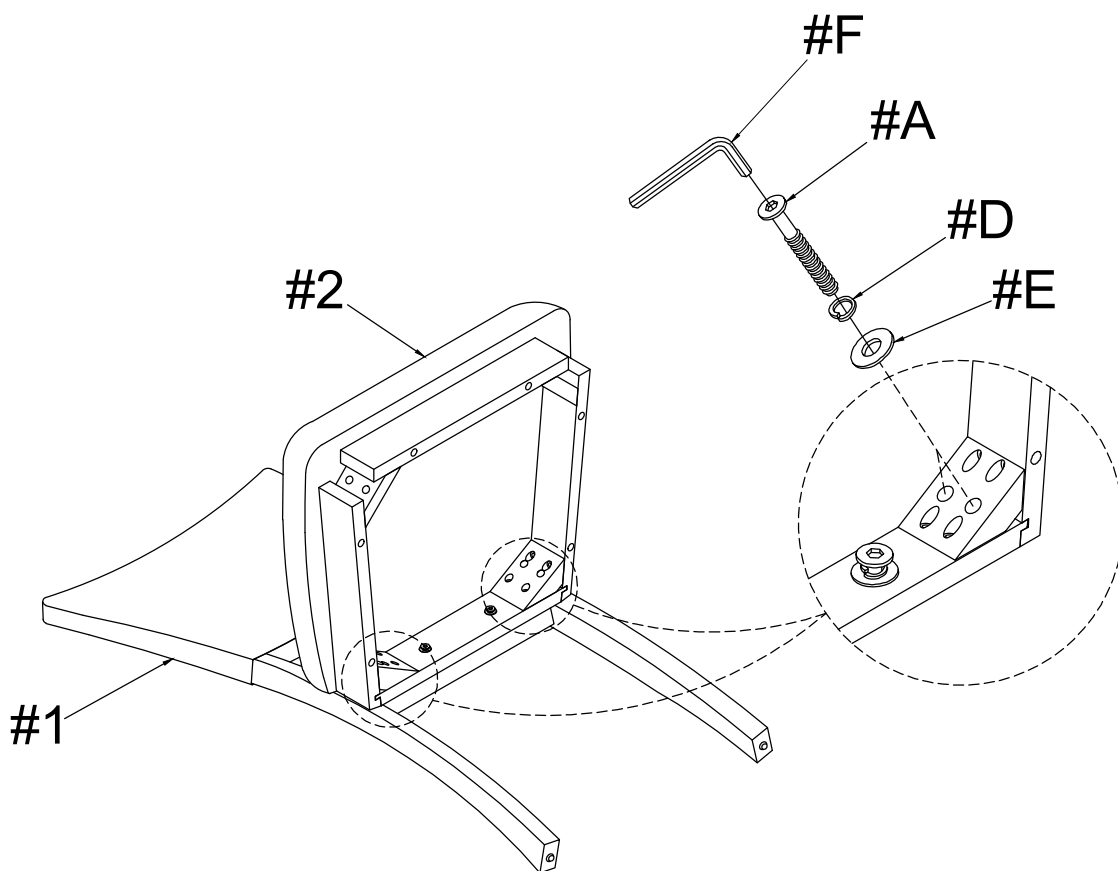

Do not tighten screws until completely assembled.

STEP 3

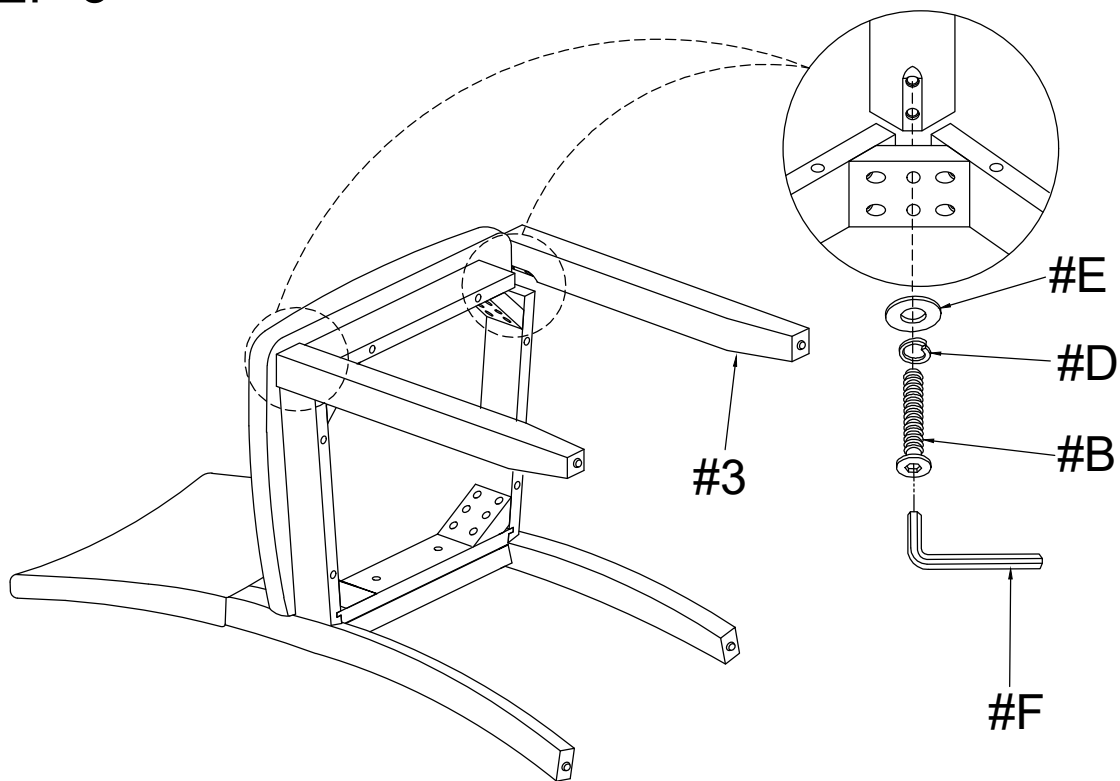

STEP 4

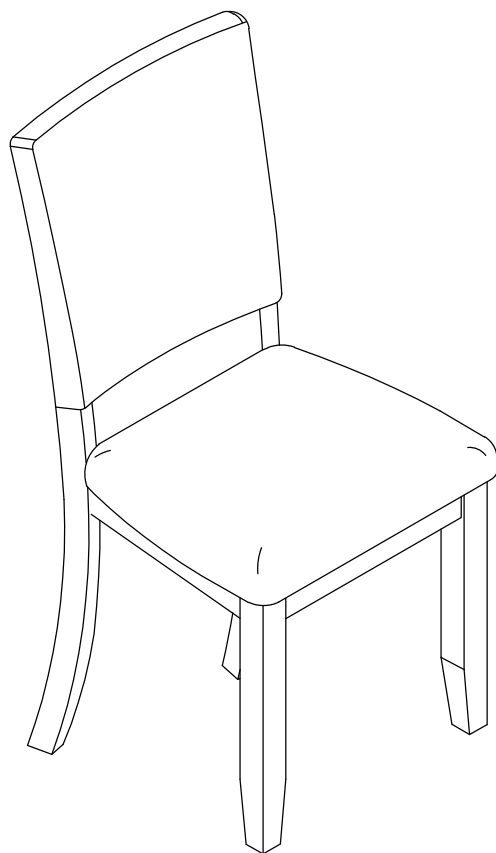

Tighten all screws until completely assembled.

ASSEMBLY INSTRUCTIONS

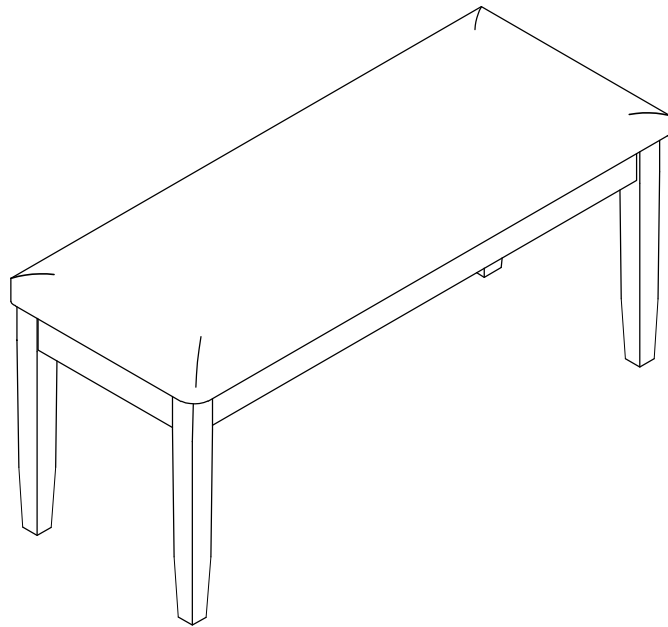

ITEM NO. FB3062HAY-BE





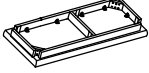

ASSEMBLY TIPS:

1. Remove hardware from box and sort by size.
2. Please check to see that all hardware and parts are present prior to start of assembly.
3. Please follow attached instructions in the same sequence as numbered to assure fast & easy assembly.

Part List

NO.	DIAGRAM	PART NAME	Q'ty
#1		Bench Seat Cushion	1 pc
#2		Bench legs	4 pcs

Part List

NO.	DIAGRAM	PART NAME	Q'ty
#A		Bolt 1/4" x 2-1/4"	8 pcs
#B		Spring washer Ø1/4"	8 pcs
#C		Flat washer Ø1/4"	8 pcs
#D		Allen key M4	1 pc

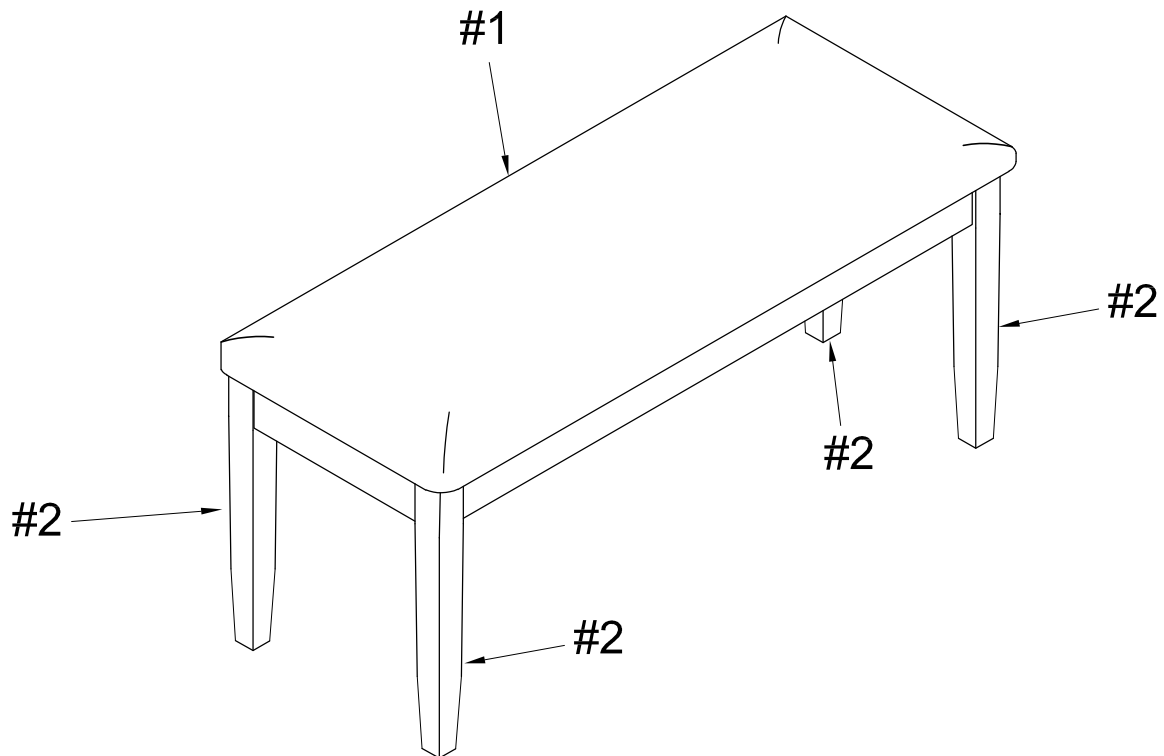

STEP 1:

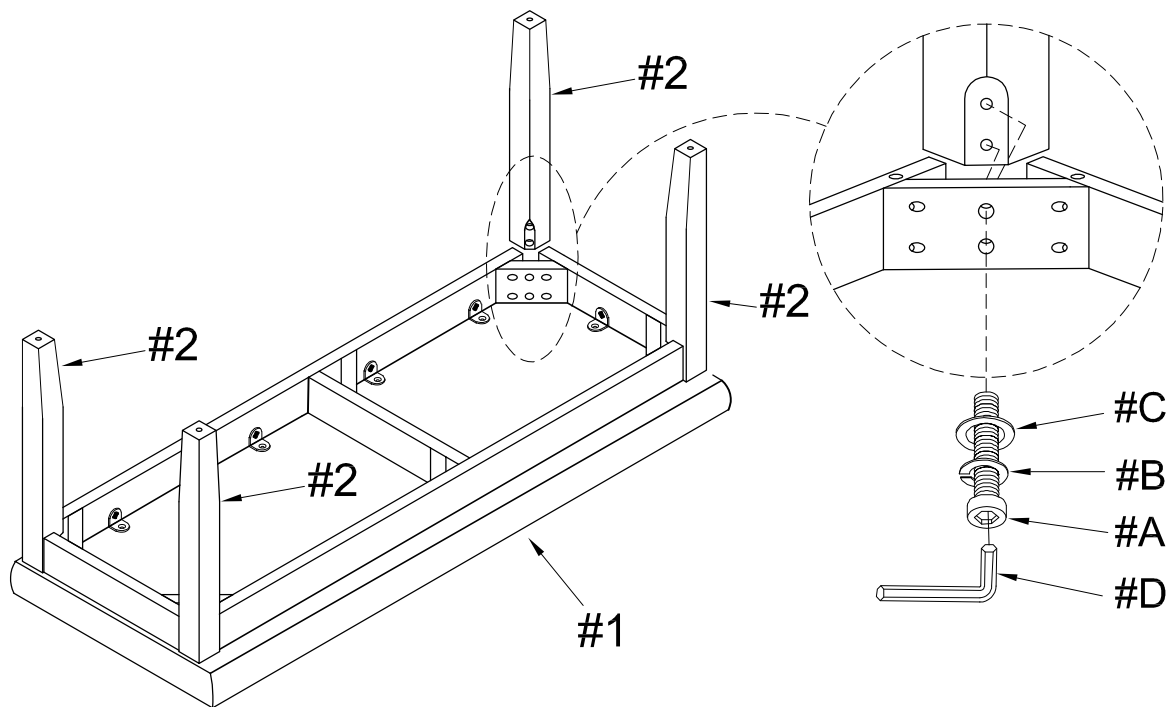

STEP 2:

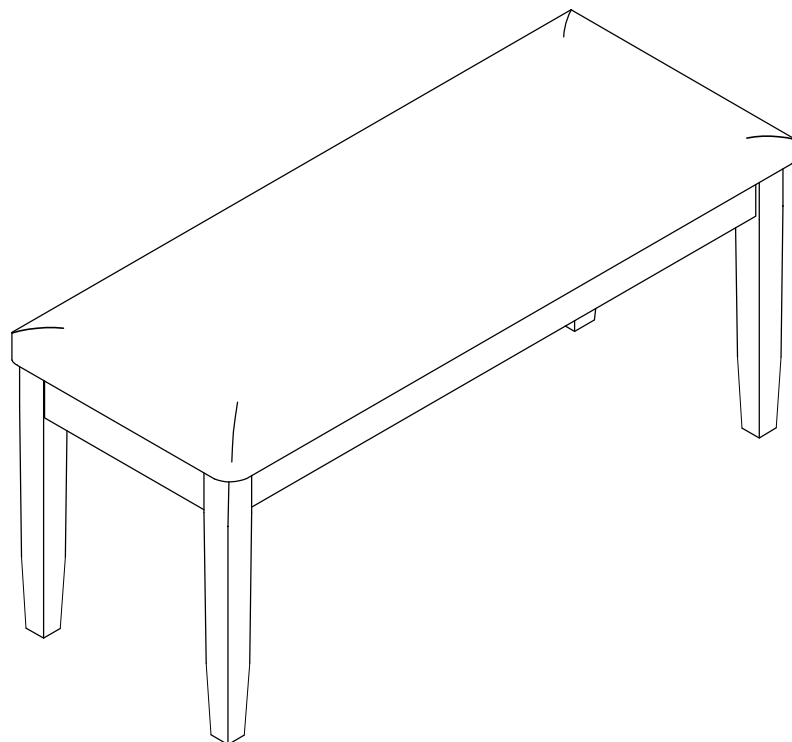

Tighten all screws until completely assembled.

ASSEMBLY INSTRUCTIONS



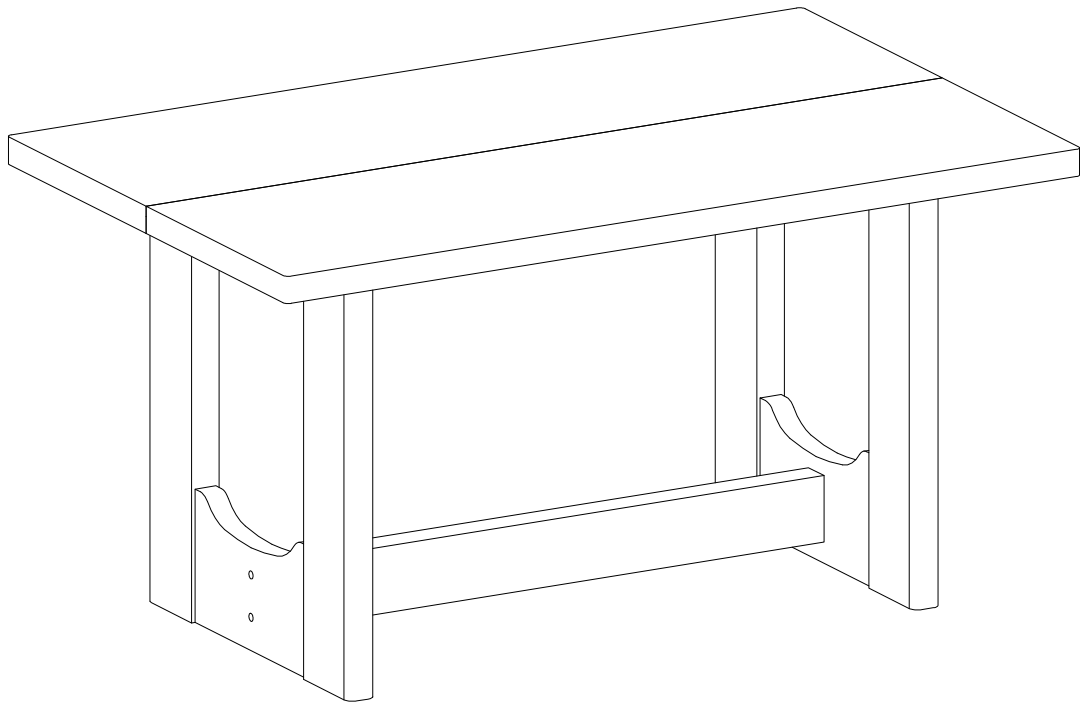

ITEM NO. FB3062HAY-A-T







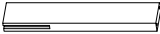

ASSEMBLY TIPS:

1. Remove hardware from box and sort by size.
2. Please check to see that all hardware and parts are present prior to start of assembly.
3. Please follow attached instructions in the same sequence as numbered to assure fast & easy assembly.

Part List

NO.	DIAGRAM	PART NAME	Q'ty
#1		Table Top	2 pcs
#2		Long Connect Panel	1 pc
#3		Short Connect Panel	4 pcs
#4		Legs	4 pcs
#5		Side Stretcher	2 pcs
#6		Center Stretcher	1 pc

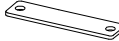
Part List

NO.	DIAGRAM	PART NAME	Q'ty
#A		Bolt 1/4" x 1-3/8"	32 pcs
#B		Bolt 1/4" x 2-1/2"	4 pcs
#C		Bolt 1/4" x 3/4"	8 pcs
#D		Spring washer Ø1/4"	32 pcs
#E		Flat washer Ø1/4"	32 pcs
#F		Wood Dowel Ø10 x 30mm	6 pcs
#G		Metal Bracket 100 x 20 x 3mm	4 pcs
#H		Allen key M4	1 pc

Bolt 1/4" x 3/4"

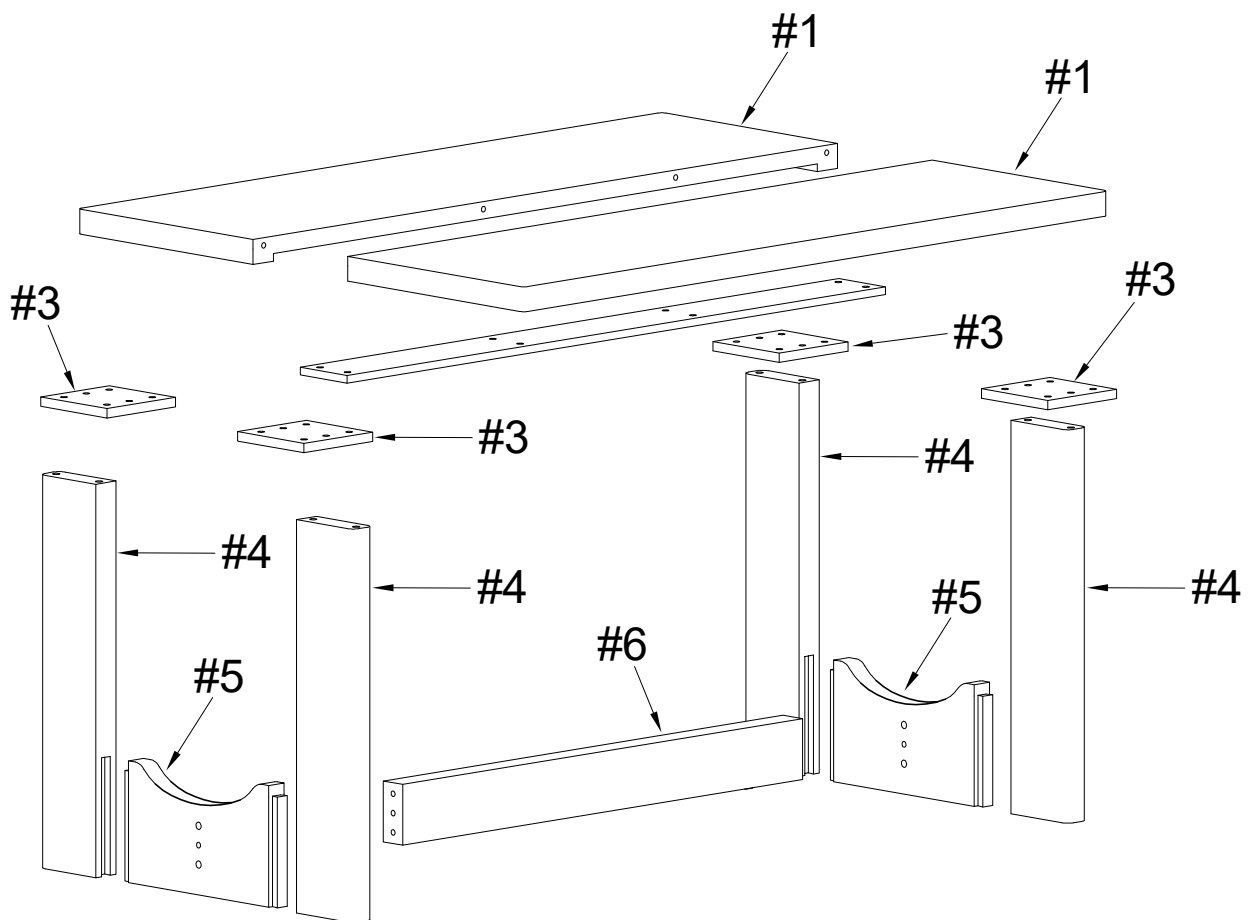

STEP 1:

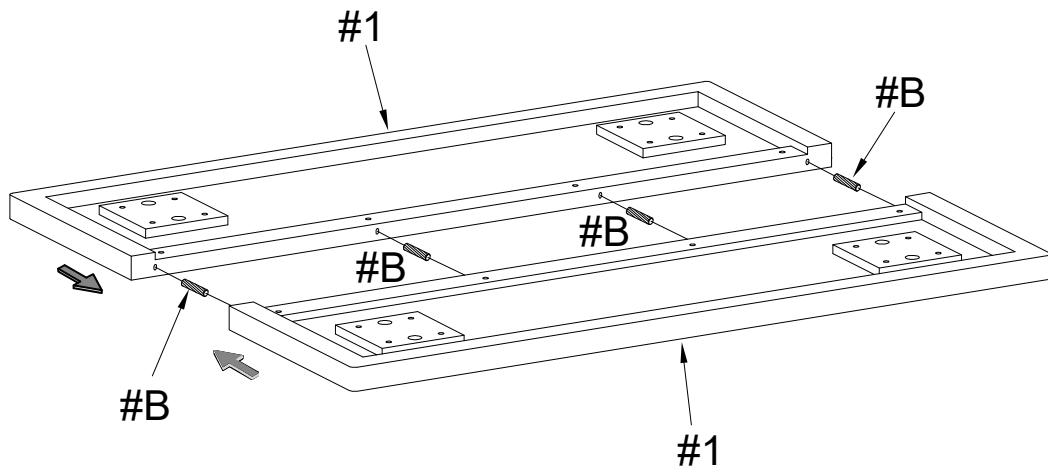

STEP 2:

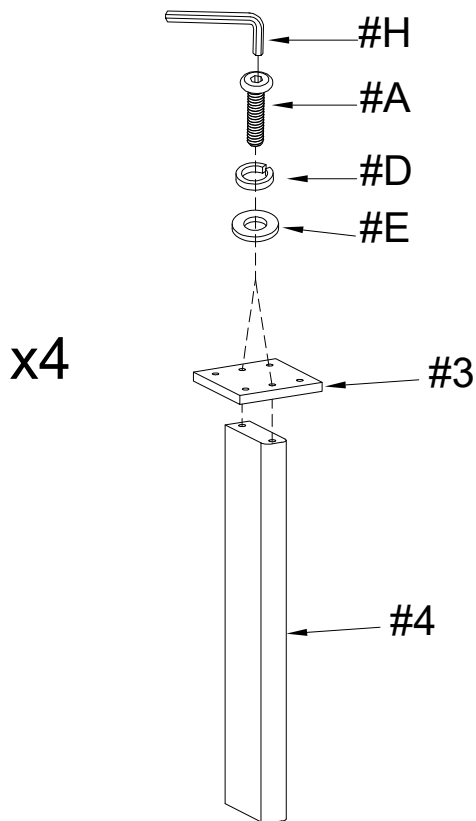

STEP 3:

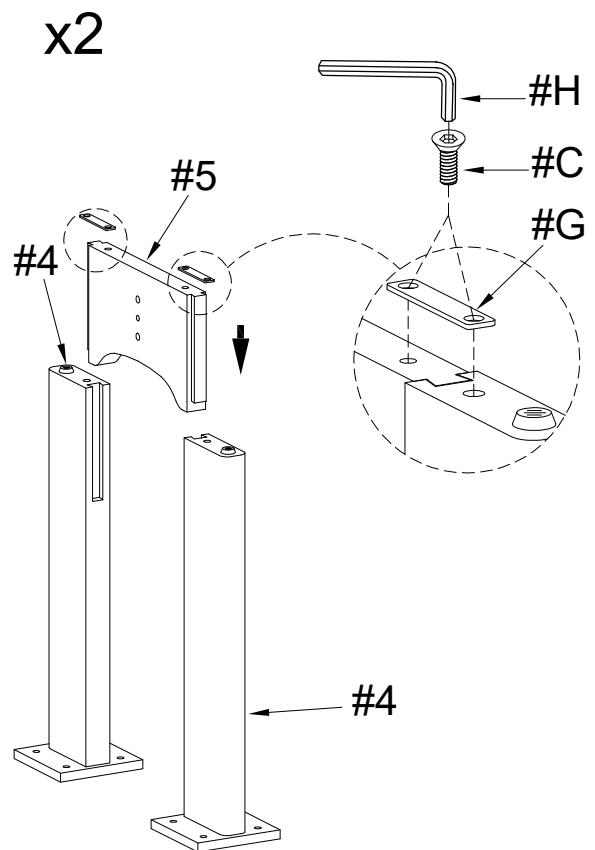

Tighten all screws until completely assembled.

STEP 4:

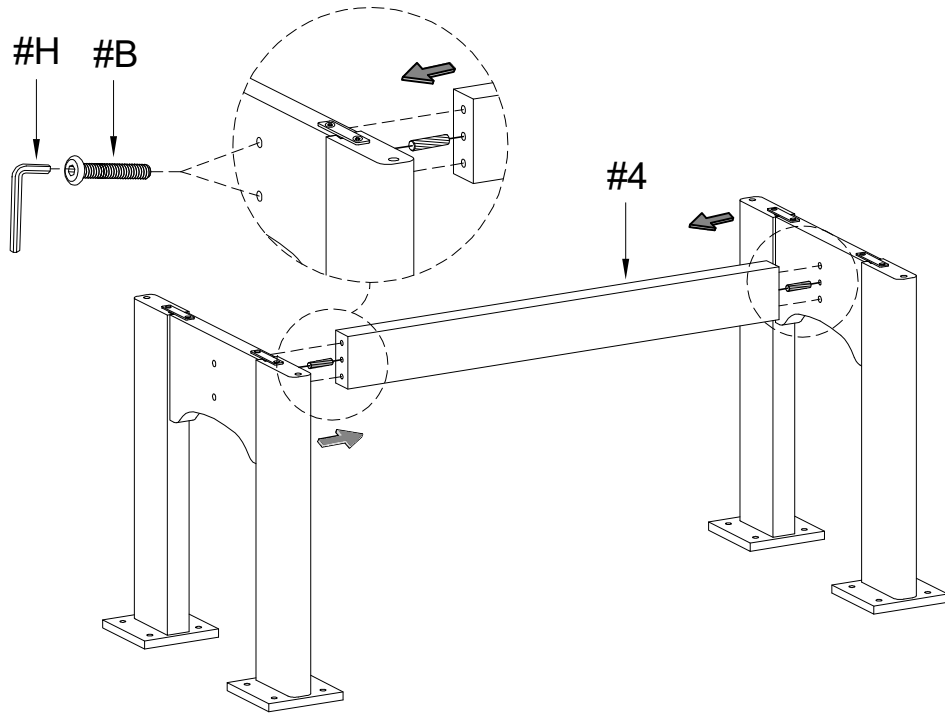

STEP 5:

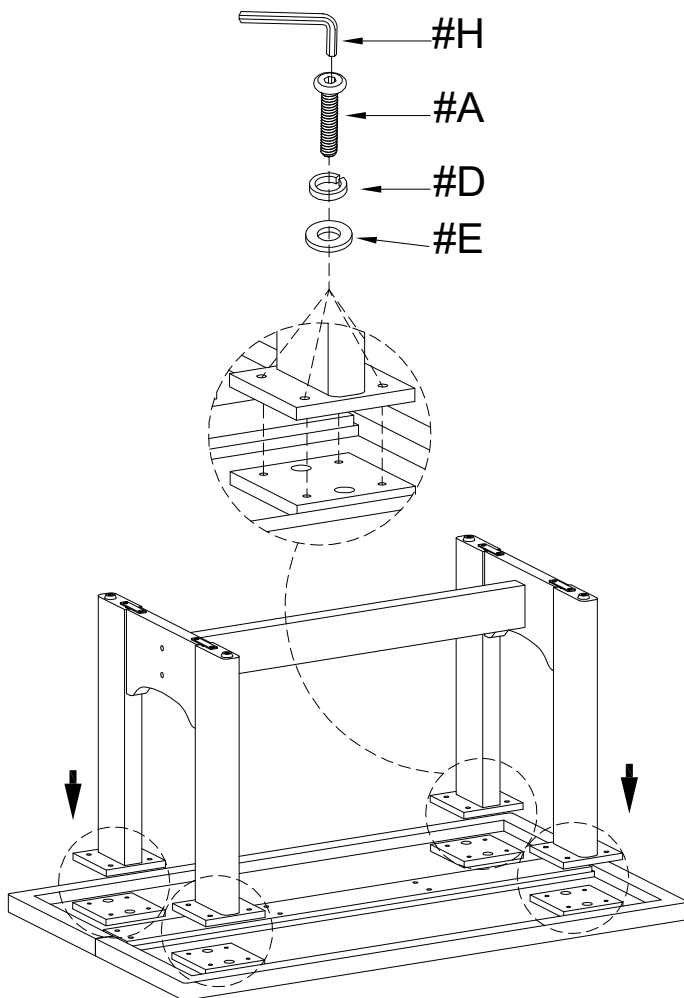

STEP 6:

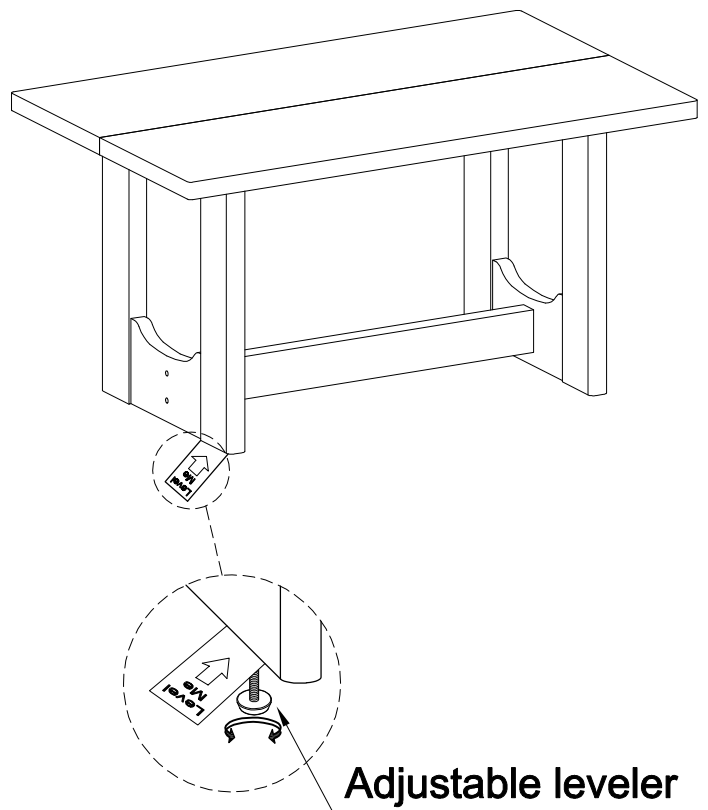

Tighten all screws until completely assembled.