

MOD-5544/5545 FULL/QUEEN BED



Thank you for purchasing the MODWAY BED !

Before you start, here are some helpful advice:

1. We suggest you spend a short time reading through this leaflet and then follow the simple step by step instructions.
2. Owing to the size and weight of the bed, we recommend that it is assembled by two adults, on a carpeted or padded area, in the room that it is intended for. Approximately assembly time: 30 minutes.
3. Please do not use any tools other than those provided or recommended in these instructions.
4. Please do not throw away any of the packaging or the instruction until you have checked all the components and hardware and the furniture is fully assembled. Please ensure that the packaging is disposed of in a safe environmentally friendly way.
5. Assemble all components loosely until advised to tighten. Depending on use, it may be necessary to tighten the components from time to time, so please save the tools that has been provided.
6. Please keep all fitting out of reach of children.

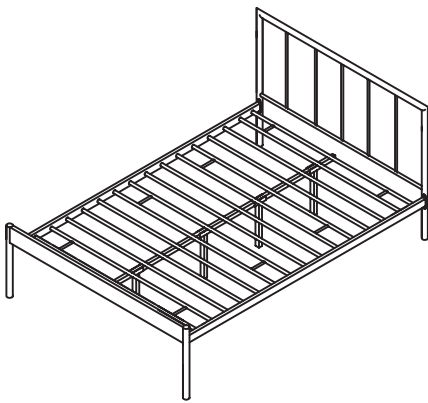

Hardware:

- | | | | | | | | |
|---|--|---------------------|-----|---|--|---------------|-----|
| A | | Short Bolt M6x20mm | x24 | F | | Rubber Insert | x16 |
| B | | Medium Bolt M6x35mm | x4 | G | | Allen Wrench | x1 |
| C | | Long Bolt M6x50mm | x4 | | | | |
| D | | M6 | x8 | | | | |
| E | | Open Wrench | x1 | | | | |

Component:

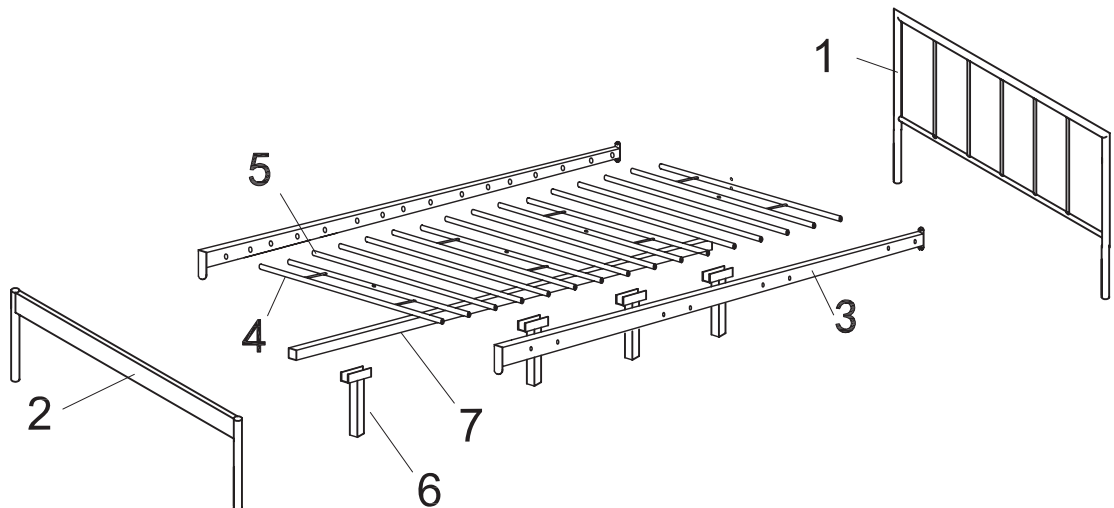

- | | | | | | |
|---|-------------|----|---|-------------|----|
| 1 | Headboard | x1 | 2 | Footboard | x1 |
| 3 | Side Rail | x2 | 4 | Double Slat | x4 |
| 5 | Single Slat | x8 | 6 | Support Leg | x4 |
| 7 | Center rail | x1 | | | |

MOD-5544/5545 FULL/QUEEN BED



STEP 1:

Insert 4 pieces of **Medium Bolt (B)** into the 4 holes on **Center Rail (7)** to connect it with **Support Legs (6)** as shown.

Please pay attention to the holes' direction.

Tighten **Medium Bolt (B)** with **Nuts (D)** by using **Allen Wrench (G)** and **Open Wrench (E)** until secure.

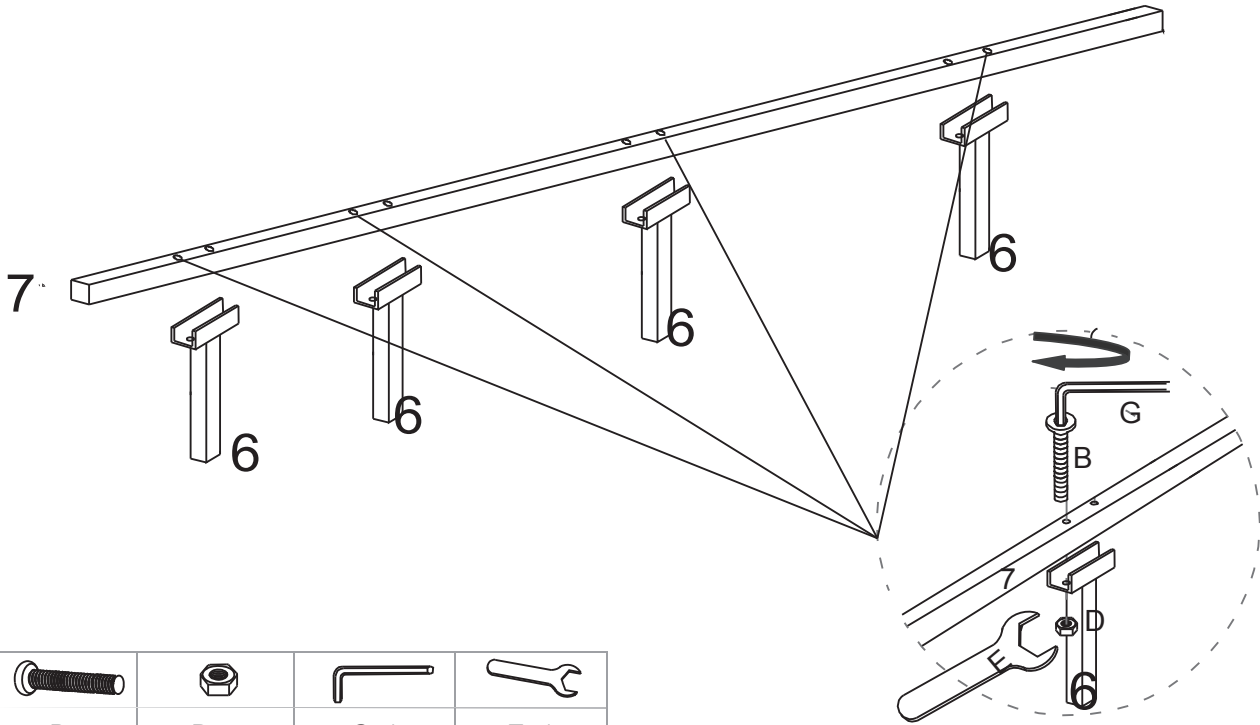

Bx4	Dx4	Gx1	Ex1

Hardware & Tool required

STEP 2:

Take out all **Double Slats (4)** and place them as shown.

Attach **Double Slats (4)** to the **Center Rail (7)** by using **Bolts (C)** and **Nuts (D)**.

Please pay attention to the holes direction on the **Double Slats (4)**.

Tighten **Long Bolts (C)** and **Nuts (D)** with **Allen Wrench (G)** and **Open Wrench (E)**.

Do not fully tighten **Long Bolts (C)** at this step.

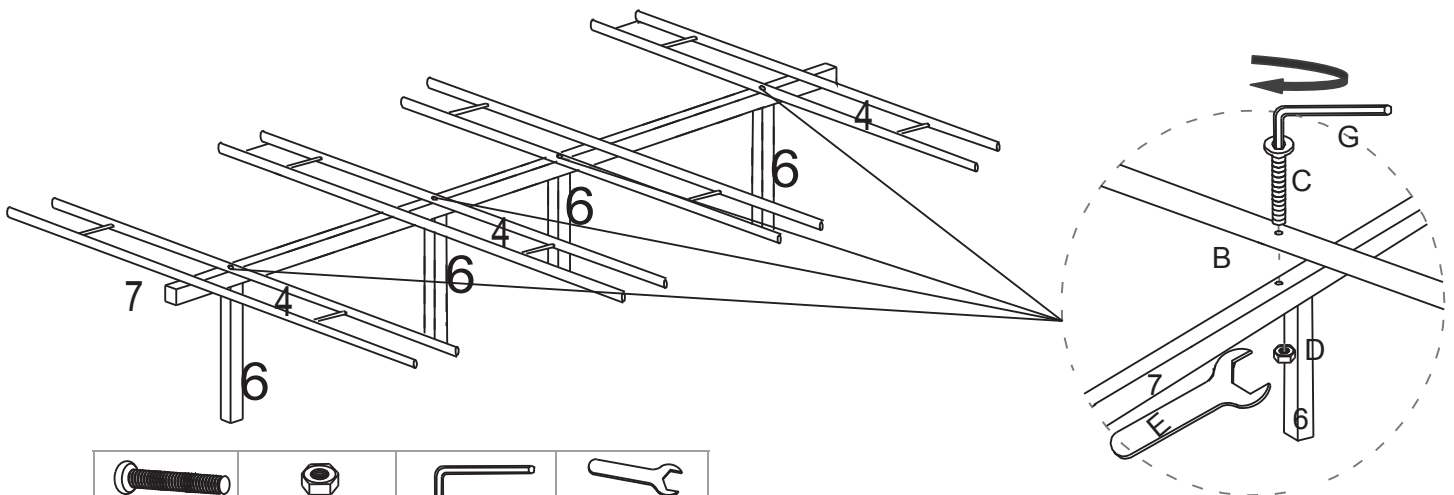

Cx4	Dx4	Gx1	Ex1

Hardware & Tool required

STEP 3:

Take out **Single Slats (5)** and place them as shown.

Insert one end of **Single Slats (5)** into **Rubber Insets (F)**, then insert them into the corresponding holes on 1 piece of **Side Rail (3)** as shown. Attach assembled **Double Slats (4)** to the **Side Rail (3)** by using **Short Bolts (A)**.

Tighten **Short Bolts (A)** with **Allen Wrench (G)**. Do not fully tighten **Short Bolts (A)** at this step.

Repeat above for the other **Side Rail (3)**.

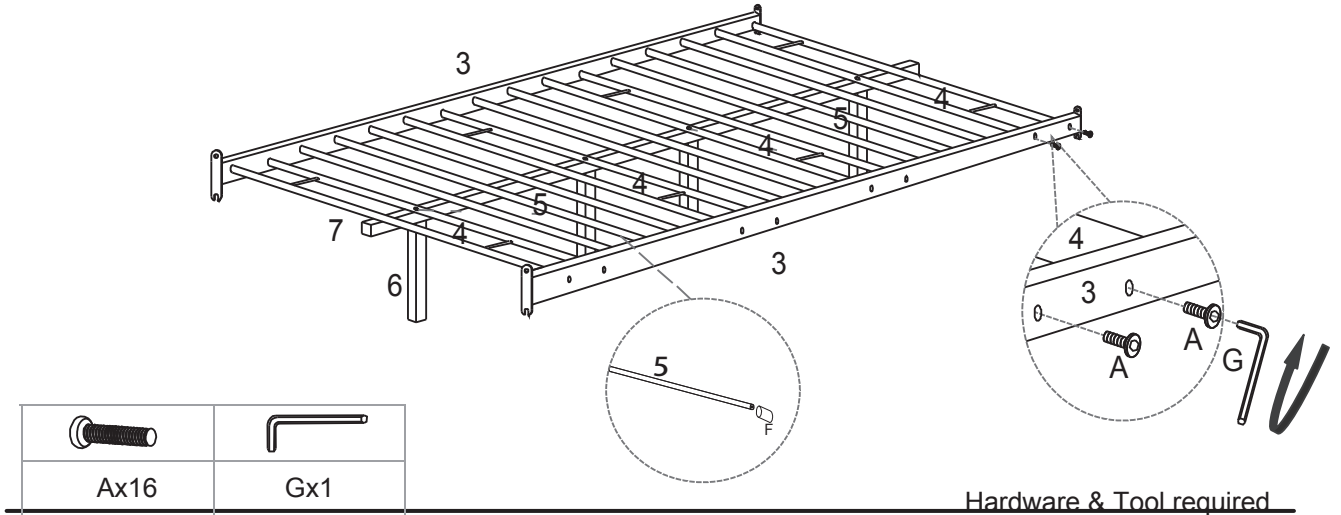

STEP 4:

Insert **Bolts (A)** into the bottom holes on the assembled **Headboard (1)** & **Footboard (2)** by hand.

Leaving 0.3~0.4inch space of the thread of **Bolts (A)** as shown.

Insert the notch of assembled **Side Rails (3)** into the space left on the **Bolts (A)**.

Screw **Bolts (A)** into the top holes on the assembled **Headboard (1)** & **Footboard (2)** as shown.

Tighten **Bolts (A)** with **Allen Wrench (G)** after all assembled.

Fully tighten **Bolts (A&C)** at this step.

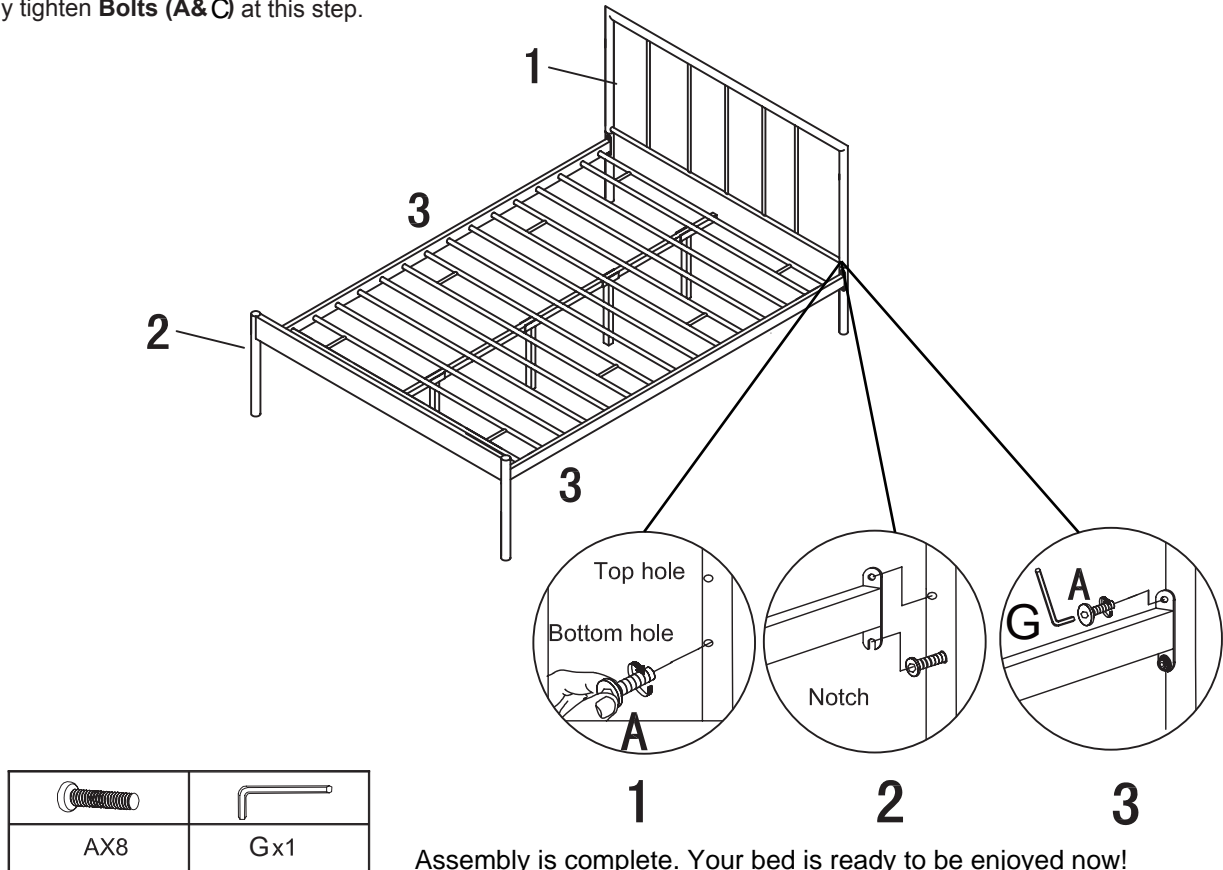

Assembly is complete. Your bed is ready to be enjoyed now!

Hardware & Tool required