

- 4** Insert backrest metal plates to both arms as shown below. Ensuring it is correctly in place.

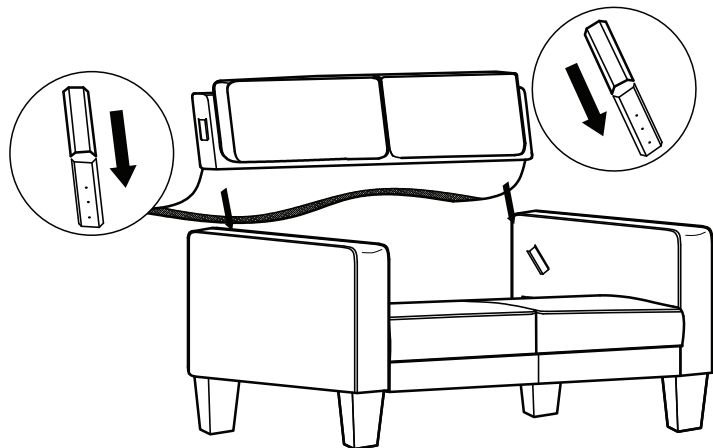

- 5** Finally, stretch and pull down rear cover evenly before securing velcro strip to seat base. Repeat if necessary for better fit.

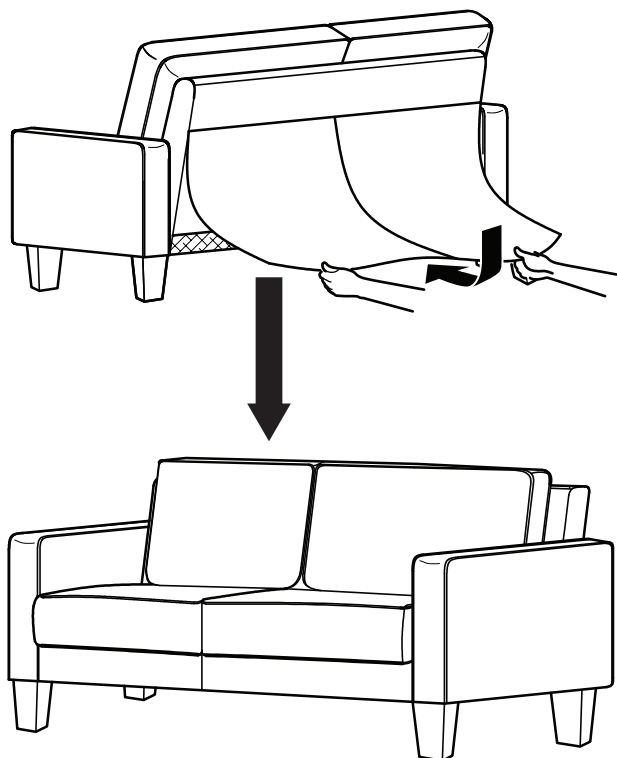

**LIFESTYLE**  
S O L U T I O N S

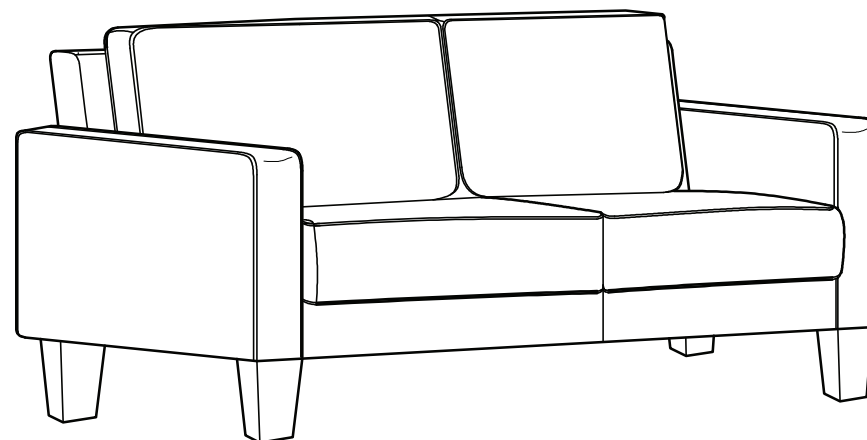

**GLENMONT** SOFA  
ASSEMBLY INSTRUCTIONS

## PARTS AND HARDWARE

Avoid using sharp objects such as a knife to open packing as you may accidentally damage the upholstery.

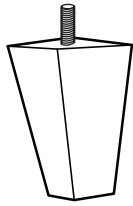

Leg  
4x



M10 Washer  
(Outer Dim. 45mm)  
4x

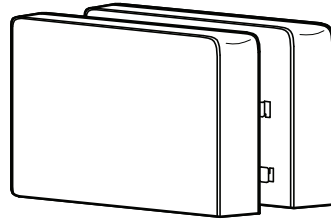

Arm  
1 Pair

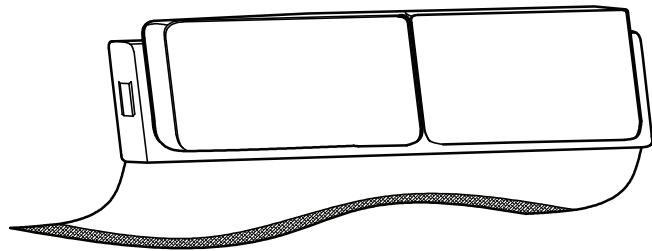

Backrest  
1x



Seat Body  
1x

## ASSEMBLY INSTRUCTIONS

**CAUTION:** At least two adults are required to safely complete performing this task.  
Other lifting attempts may risk back injury due to large and heavy part(s).



- 1 Carefully unpack parts/hardware from storage of seat body and place on a clean flat surface.

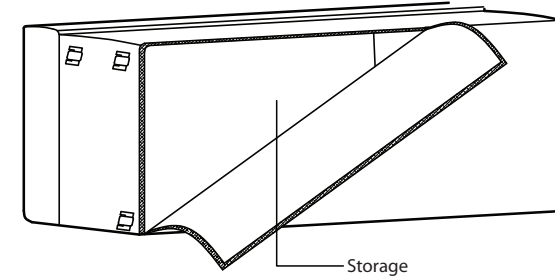

- 2 Place both arms as shown below, secure two legs and plastic washers into pre-drilled holes on the bottom of arms. Please avoid overtightening.

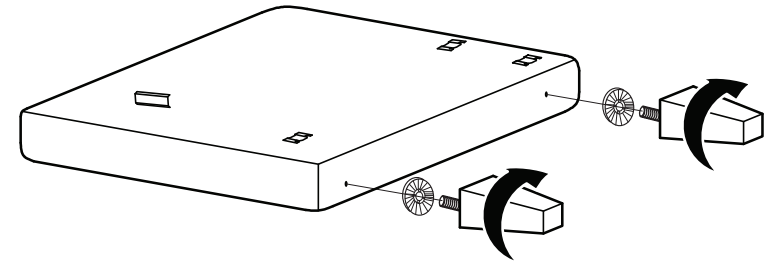

- 3 Carefully lift and turn assembled arms onto its legs. Insert seat body metal plates to both arms as shown below. Ensure it is correctly in place.

