



PREMIUM HOME SOLUTION



USE AND CARE GUIDE

PV-469

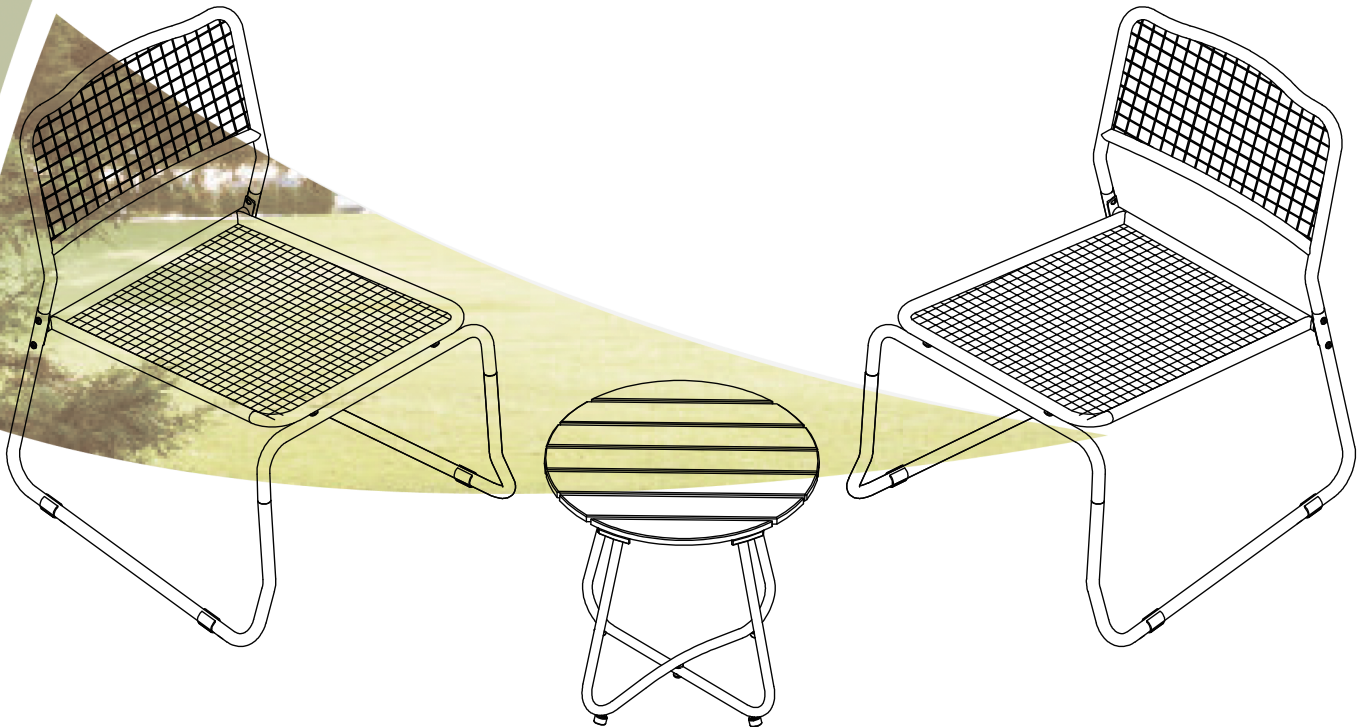

Questions, problems, missing parts? Before returning to the store please contact our Customer Service

• service@alphamarts.com •

THANK YOU

We appreciate the trust and confidence you have placed in us through the purchase of our product. We strive to continually create quality products designed to enhance your home. Visit us online to see our full line of products available for your home improvement needs. Thank you for choosing us!

Notice

1.50% Tighten before fixings all screws, Allen wrench is recommended instead of an electric drill.

2.Place the item on a flat ground to adjust and make sure it remains stable.

3.Tighten up all screws with tools gradually.

4.If the screws are not aligned with holes during assembly, please loosen all all the other screws to 50% and continue the assembly process.

5.If the item is not stable, please loosen all the screws, adjust it on a flat ground and tighten up all screws again.

6.Note: If one or more screws are fully tightened during assembly,chances are the others will not be aligned with holes. In addition, all the holes are disigned to be relatively larger to provide more space for the adjustment of the screws.

Warranty

LIMITED WARRANTY

This warranty is a limited warranty, and applies to the original purchase is required. This is a residential warranty and does not apply to commercial use. This collection carries a (1) year limited warranty and is valid from original date of purchase to the original owner (proof of purchase required).

WHAT IS COVERED

We warrant the frame to be free of Manufacturing defects to the original purchaser for one year.

WHAT IS NOT COVERED

This warranty does not cover commercial use, hardware, acts of nature, fire, freezing and abusive.

In addition, purchased parts are not covered under this warranty.

We reserve the right to make substitutions with similar merchandise, if the model in question is no longer in production.

For a copy of our full limited warranty, please contact our customer service team below.

Pre-assembly (continued)

Assemble the item on a soft, non-abrasive surface, such as carpet or cardboard to avoid damaging the item. Seek assistance to assemble bulky or heavy items.







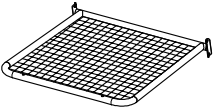
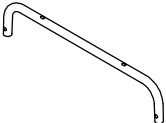
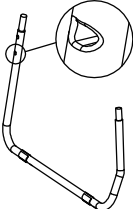
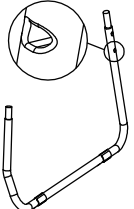
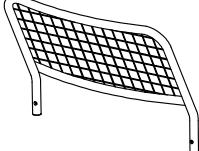
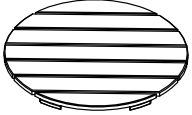
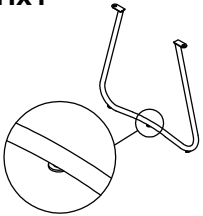
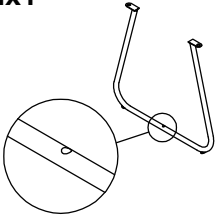
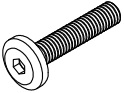
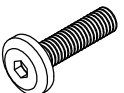

NOTE: Identify all parts packed in the carton against the parts list. Remove all the protective material carefully and DO NOT use a knife to prevent scratching the furniture.

PACKAGE CONTENTS

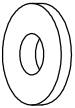
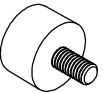

NOTE: Hardware not shown to actual size.

| | | | | | |
|--|--|---|---|--|---|
| Ax2  | Bx2  | Cx2  | Dx2  | Ex2  | Gx1  |
| Hx1  | Ix1  | Jx4  M6x35 | Kx9  M6x30 | Lx4  M6x15 | Mx8  M6x10 |
| Nx8  M6 | Ox17  D16/7x1 | Px4  M6x25/D20 | Qx1  4 | Rx1  Cle 10 | |

Assembly: Table

1

⚠️ 50%
50% ✓ 100% ✗

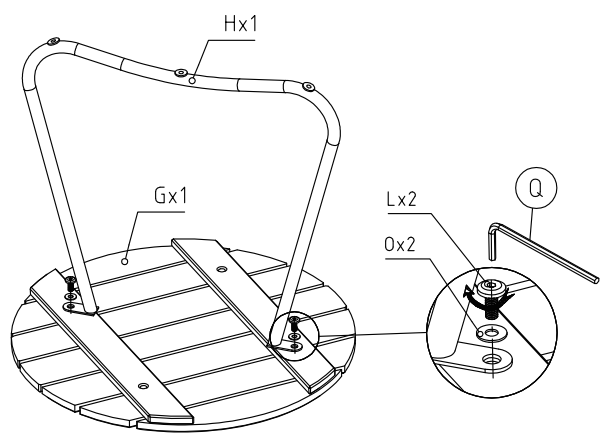

2

⚠️ 50%
50% ✓ 100% ✗

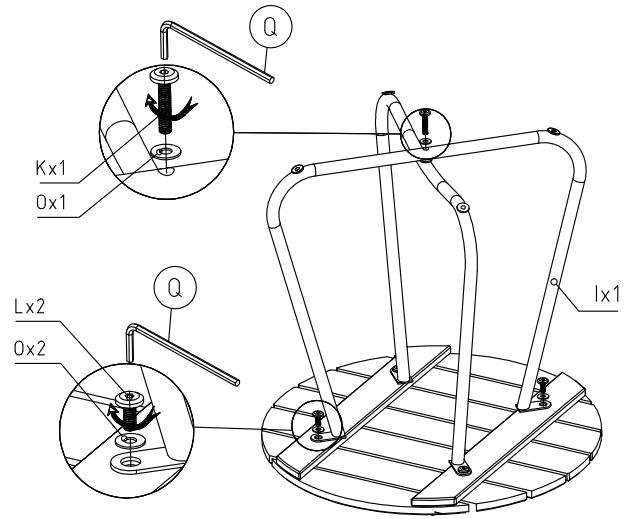

3

⚠️ 50%
50% ✓ 100% ✗

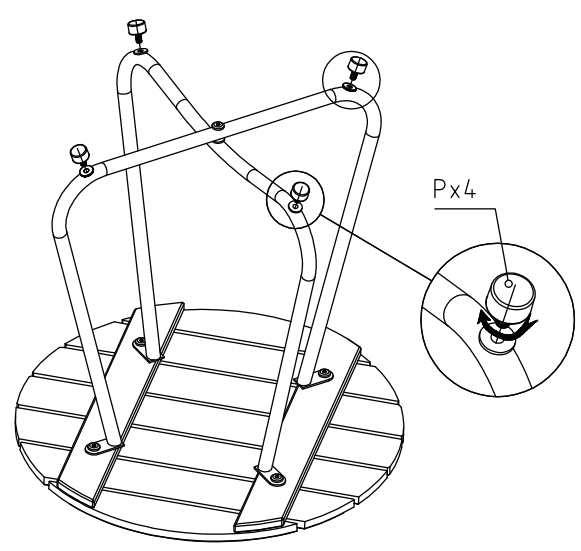

4

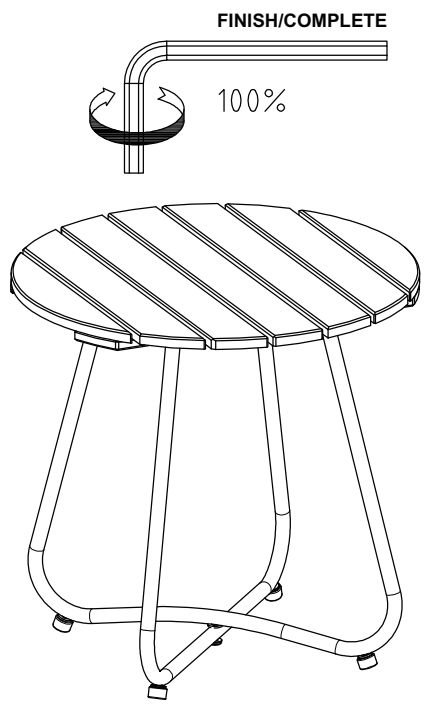

Assembly: Armless Chair

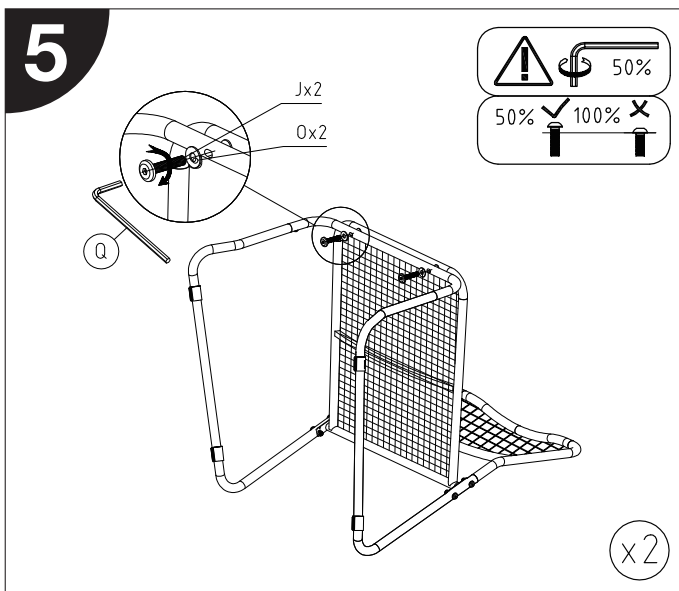
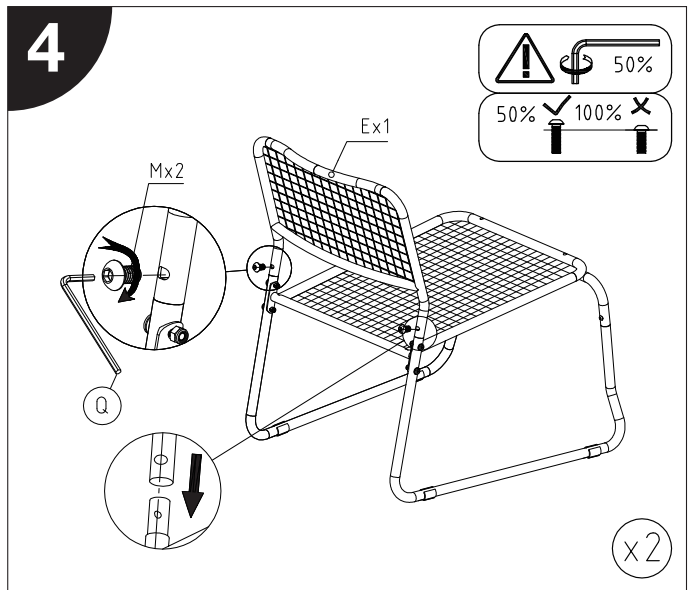
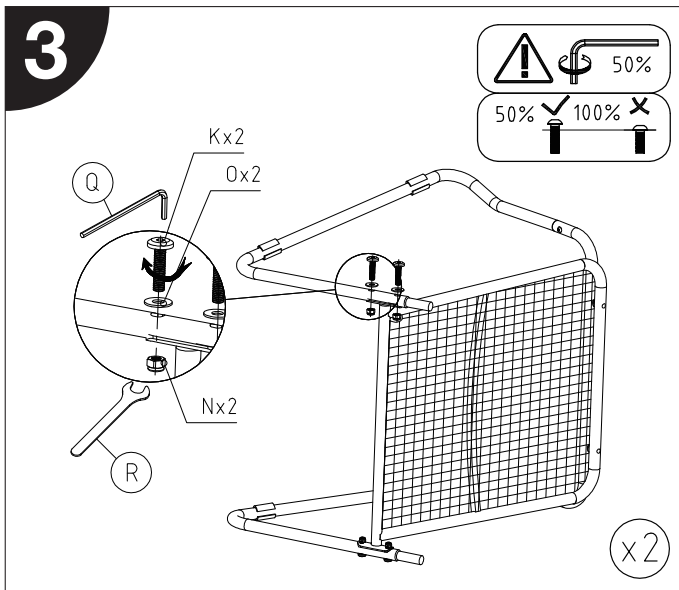
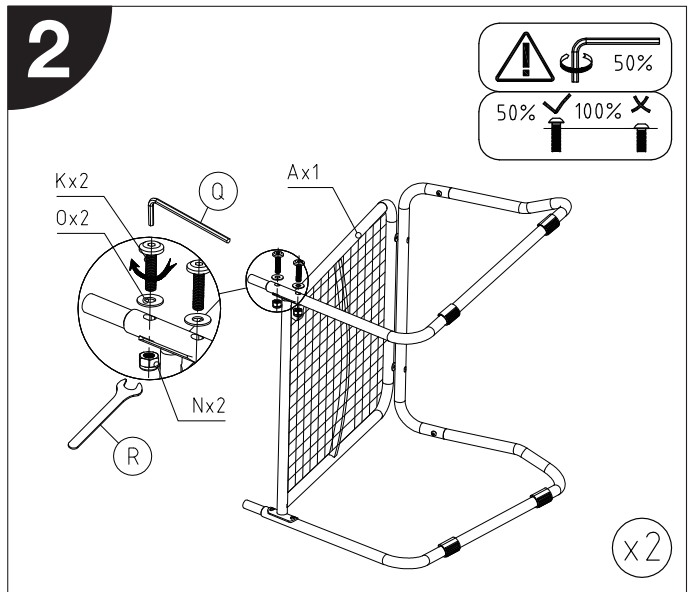
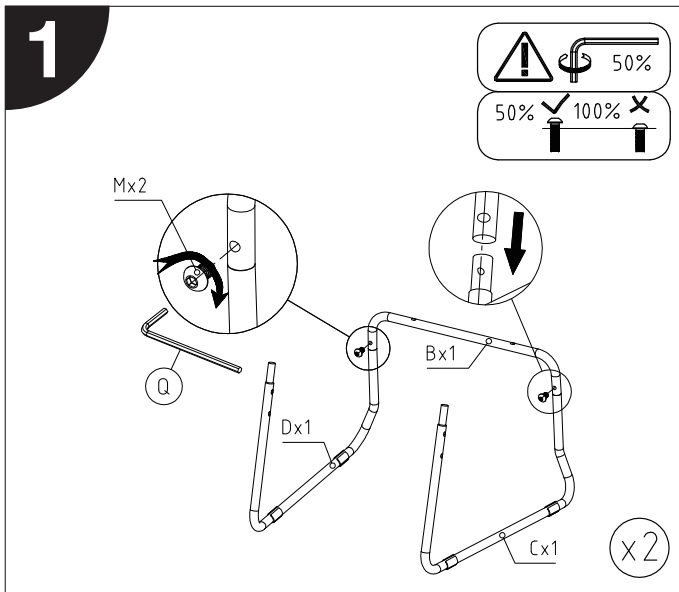

Cleaning and Maintenance

- Clean the furniture with damp cloth, rinse thoroughly. Dry frame parts completely. Do not use bleach, acid or other solvents on the textile or metal parts.
- We recommend the use of furniture covers to protect the product when not in use.
- Inspect and tighten all screws on a regular basis to ensure proper performance and safety.
- In order to prolong the life and beauty of your product, we recommend storing it in a dry and protected area during off season periods.



Questions, problems, missing parts? Before returning to the store
please contact our Customer Service

• service@alphamarts.com •

1-877-606-2818