

RANGE

OUTDOOR LIVING

Manufactured by:
Range Outdoor Living
3305 Airport Drive, Pittsburg, KS 66762
800-856-4445

Basepoint Business Centre: Rivermead Drive, Westlea, Swindon SN5 7EX Phone: 0800-118-2476
J.P. Coenstraat 7, The Bridge, The Hague, 2595 WP, Netherlands Phone: 08005678990

14x12 LODGE GAZEBO

MODEL # : 2506053



Please visit www.rangeoutdoorliving.com
For the most up to date assembly manual, to register your product, or to order
replacement parts *Para obtener instrucciones en español, visite*
www.rangeoutdoorliving.com



EASY STEP-BY-STEP
3D INTERACTIVE INSTRUCTIONS
DOWNLOAD THE FREE APP



OWNER'S MANUAL - BASIC SETUP DIMENSIONS & ASSEMBLY NOTES

It is critically important that you start with square and level footings or concrete pad to attach your structure

- Pay close attention to the items needed for each step. Make sure you are using the correct hardware for each step. Using incorrect hardware may result in improper assembly
- Remember to double check for underground utilities and overhead electrical lines

Post mounts are provided with your structure which allows you to permanently install your structure to a pre-existing or new wood or concrete surface. See Anchor Instructions for further details and recommendations.

- The hardware to attach the post mounts to the structure is included.
- The hardware to mount the structure permanently to a concrete surface is included.
- The hardware to mount the structure permanently to a wood deck is NOT included and will need to be purchased separately. You must ensure there is ample structural support under the deck before permanently attaching.

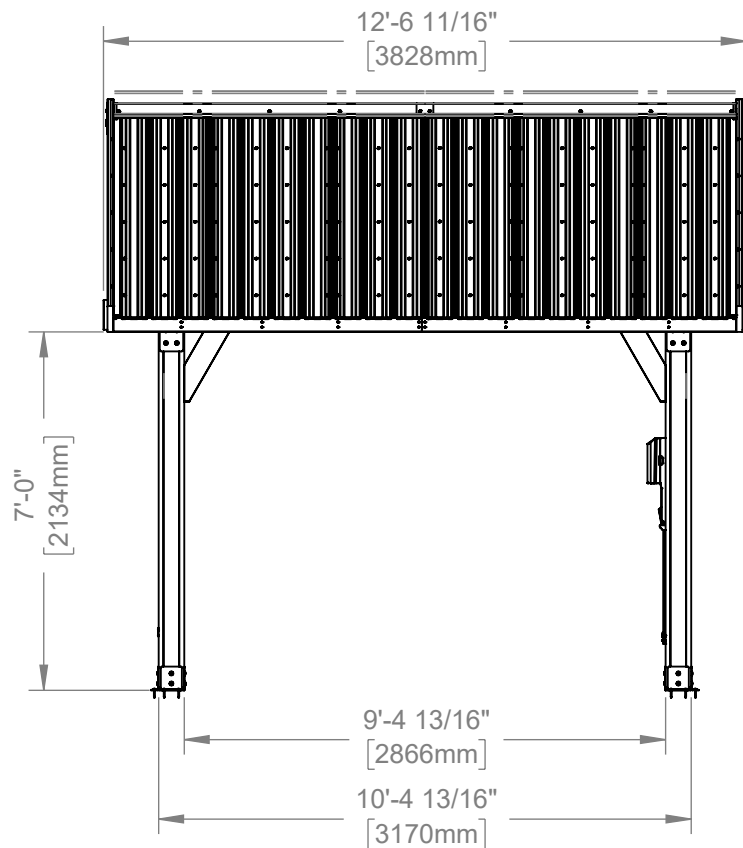
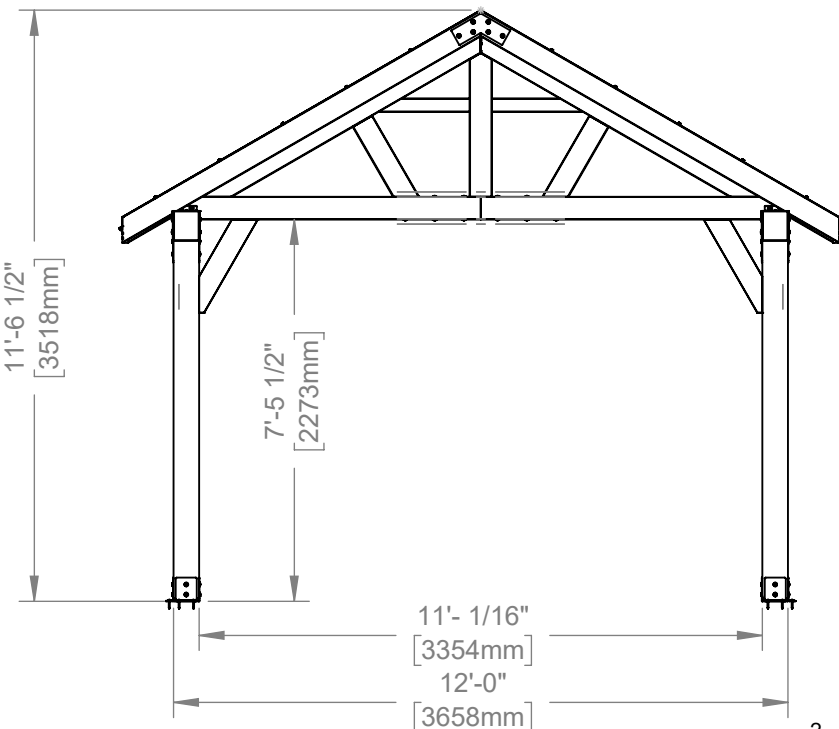
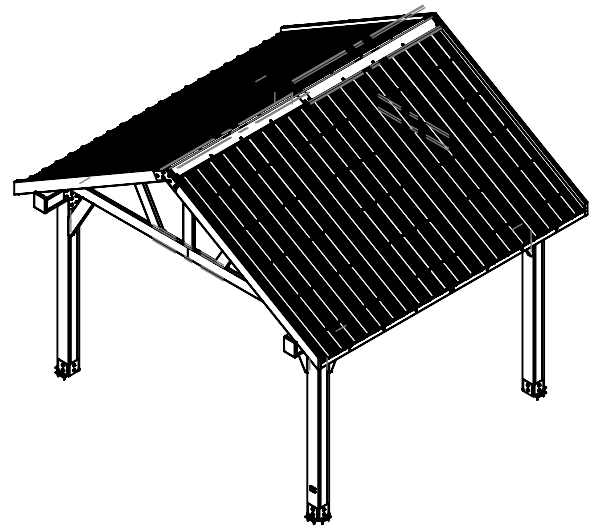
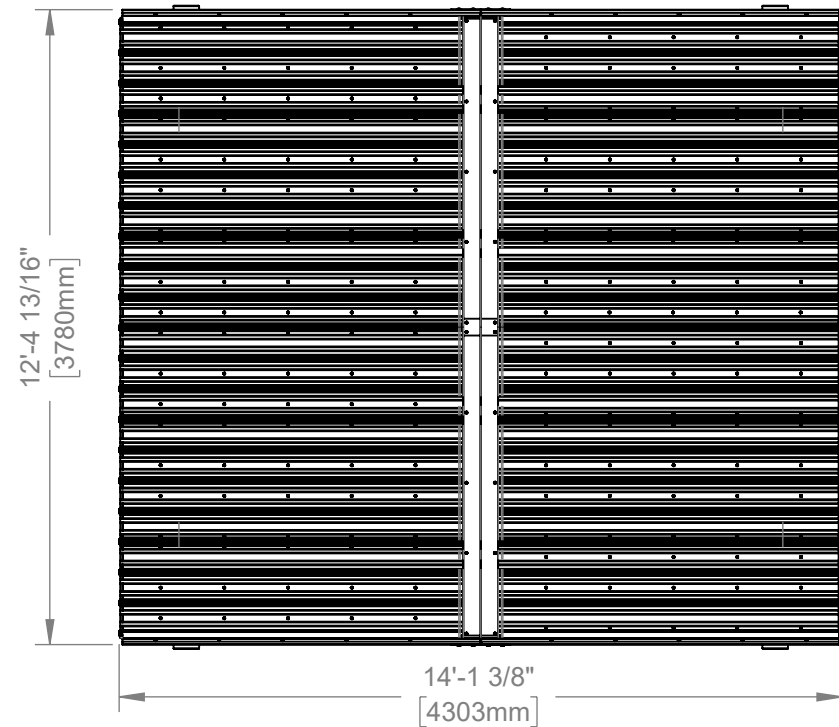

OWNER'S MANUAL - ANCHORING LAYOUT

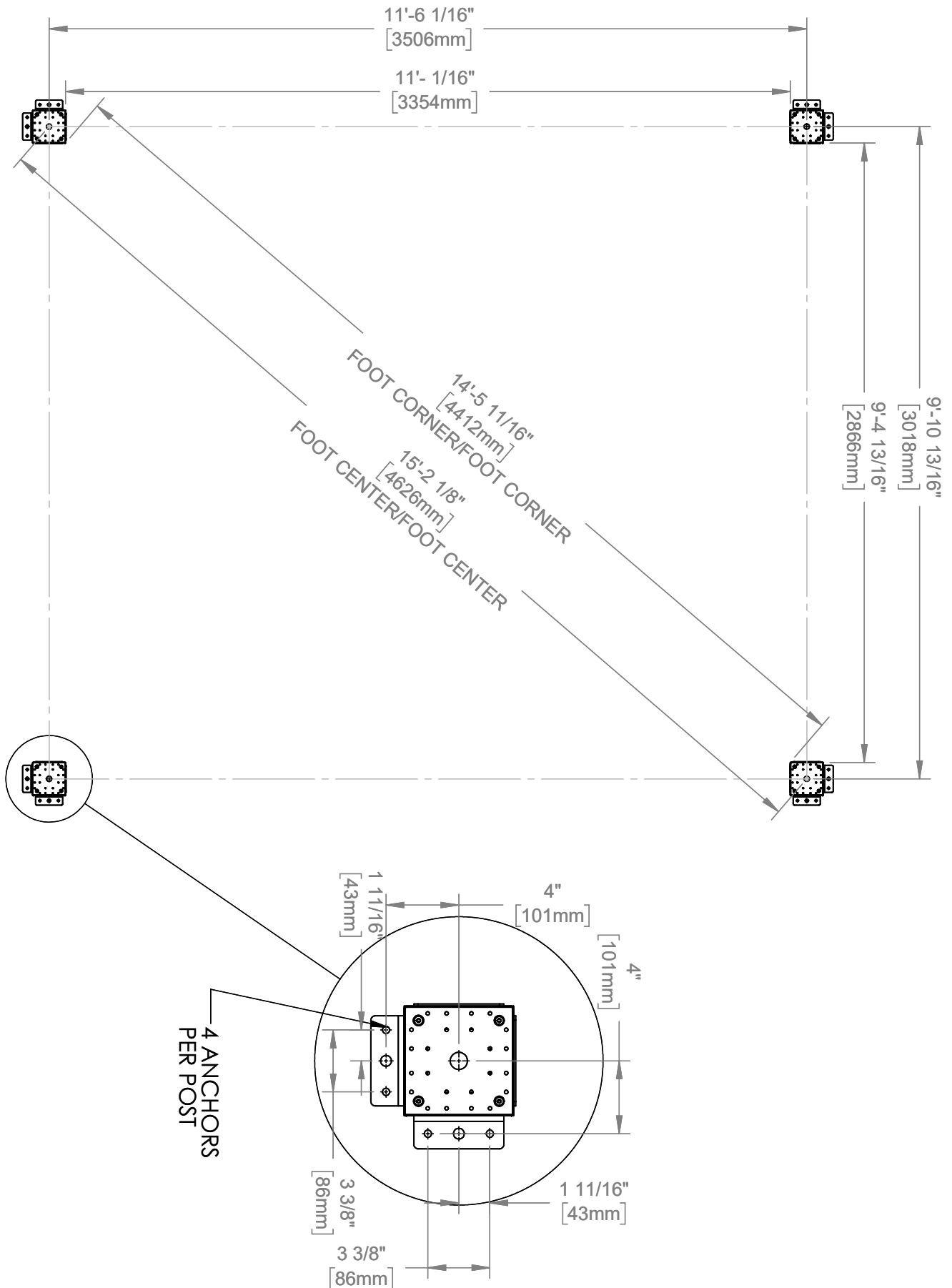

NOTE: DIMENSIONS ARE TO ANCHOR PLATES MOUNTED TO POSTS EXCEPT WHERE NOTED.

OWNER'S MANUAL - PARTS IDENTIFICATION

Wood Components (NOT TO SCALE)



D01 FASCIA - W4L21164
(x2) 1 7/16"x5 1/4"x100" (36x134x2540)

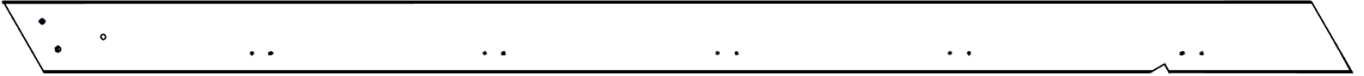

D02 FASCIA - W4L21175
(x2) 1 7/16"x5 1/4"x100" (36x134x2540)

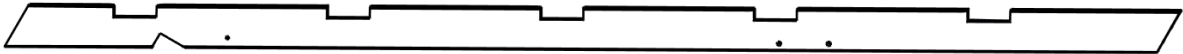

E02 RAFTER - W4L21178
(x4) 1 7/16"x3 3/8"x95 1/16" (36x86x2414)



E03 TRIM BOARD - W4L21165
(x2) 1 7/16"x3 3/8"x72 5/16" (36x86x1836)

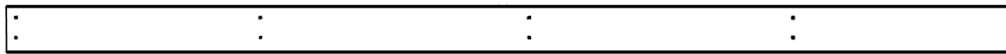

E05 TRIM BOARD - W4L21564
(x1) 1 7/16"x3 3/8"x73 11/16" (36x86x1872)

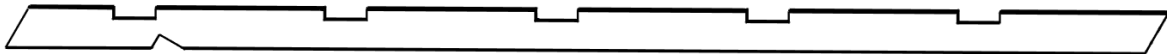

E07 RAFTER - W4L21561
(x4) 1 7/16"x3 3/8"x95 1/16" (36x86x2414)

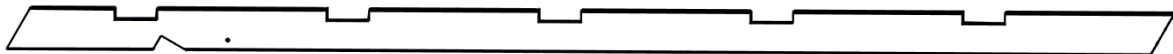

E08 RAFTER - W4L21799
(x4) 1 7/16"x3 3/8"x95 1/16" (36x86x2414)



E09 ROOF TRIM W/ PRODUCT ID TAG - W2A04546
(x1) 1 1/2"x3 3/8"x73 11/16" (39x86x1872)

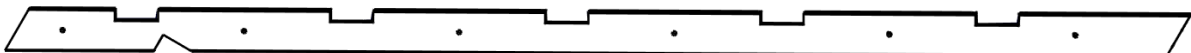

E11 RAFTER - W4L21895
(x4) 1 7/16"x3 3/8"x95 1/16" (36x86x2414)

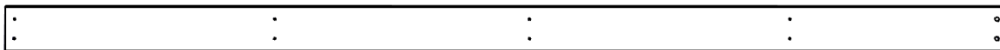

H01 PURLIN - W4L21166
(x10) 15/16"x3 3/8"x73 5/8" (24x86x1870)

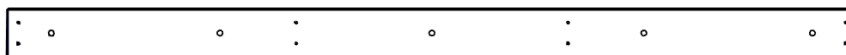

H02 PURLIN - W4L21557
(x10) 15/16"x3 3/8"x72 3/16" (24x86x1834)

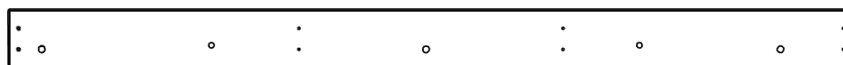

AD01 RIDGE SUPPORT - W4L21168
(x1) 15/16"x4"x58 1/2" (24x102x1486)

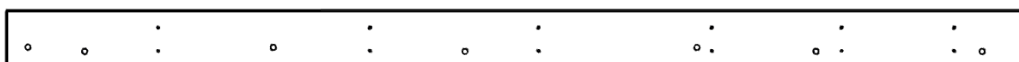

AD02 PEAK SUPPORT - W4L21169
(x1) 15/16"x4"x69 3/4" (24x102x1771)

OWNER'S MANUAL - PARTS IDENTIFICATION

Wood Components (NOT TO SCALE)

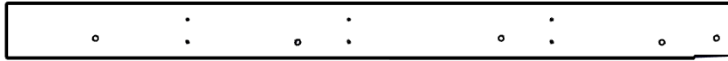

AD03 PEAK SUPPORT - W4L21170
(x1) 15/16"x4"x52 1/8" (24x102x1324)



AD04 PEAK SUPPORT - W4L21171
(x1) 15/16"x4"x69 3/4" (24x102x1771)



AD05 PEAK SUPPORT - W4L21172
(x1) 15/16"x4"x52 1/8" (24x102x1324)



AD06 RIDGE SUPPORT - W4L21181
(x1) 15/16"x4"x57 1/16" (24x102x1450)

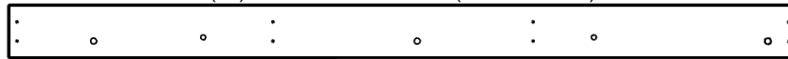

AD07 RIDGE SUPPORT - W4L21559
(x1) 15/16"x4"x57 1/16" (24x102x1450)

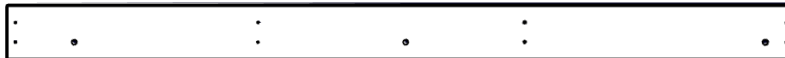

AD08 RIDGE SUPPORT - W4L21560
(x1) 15/16"x4"x58 1/2" (24x102x1486)

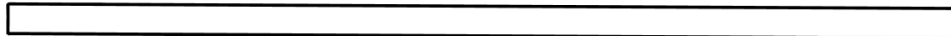

J02 RIDGE CAP STIFFENER - W4L21177
(x2) 15/16"X2 3/8"X62 7/8" (24x60x1597)

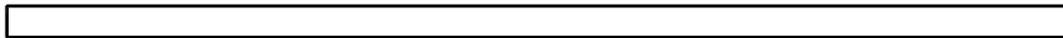

J03 RIDGE CAP STIFFENER - W4L21180
(x2) 15/16"X2 3/8"X82 5/8" (24x60x2100)

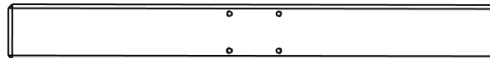

BS01 BEAM SPLICE - W4L21556
(x2) 3 3/8"X4 3/8"X39 3/8" (87x112x1000)



P01 POST - W2A04544
(x2) 6"X6"X89 3/8" (152x152x2270)

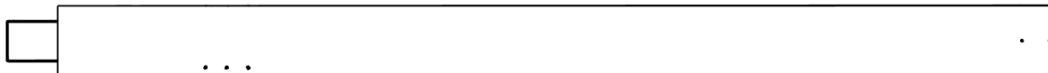

P02 POST - W2A04545
(x2) 6"X6"X89 3/8" (152x152x2270)

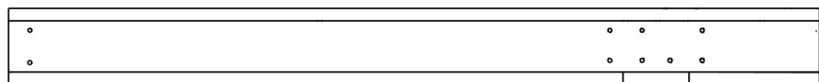

P03 BEAM - W2A04479
(x2) 6"x6 15/16"x75 3/8" (152x177x1914)

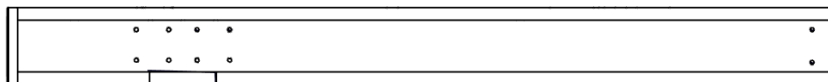

P04 BEAM - W2A04480
(x2) 6"x6 15/16"x81 5/16" (152x177x1914)

OWNERS MANUAL - PARTS IDENTIFICATION

Accessory Components (NOT TO SCALE)

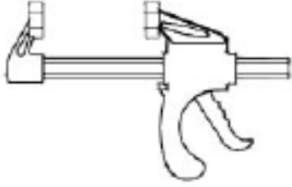

A6P00460 6" QUICK RELEASE BAR CLAMP (x2)

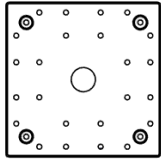

A6P00308 6x6 POST FOOT (x4)

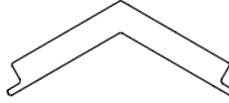

A6P00693 RIDGE CAP PROTECTOR (x2)

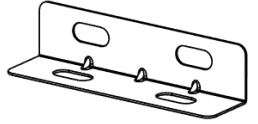

A4M04324 GABLE BEAM BRACE (x8)

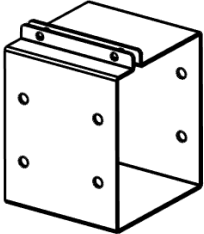

A4M04909 BEAM BAND (x2)

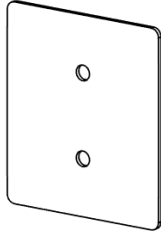

A4M00978 POST PLATE (x8)

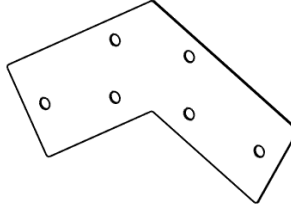

A4M02086 GABLE BRACKET (x2)

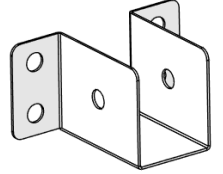

A4M04905 RIDGE CLIP (x2)

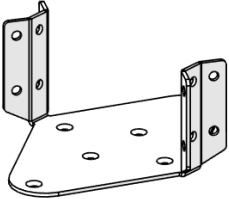

A4M02501 FAN MOUNT BRACKET (x1)

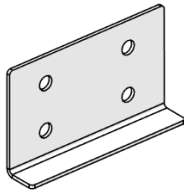

A4M01560 OUTSIDE TIE BRACKET (x2)

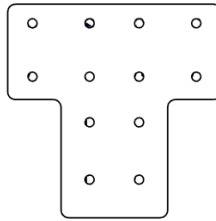

A4M04104 POST SUPPORT BRACKET (x4)

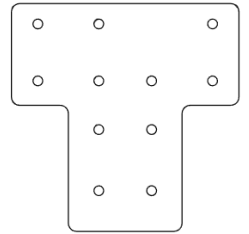

A4M04906 POST SUPPORT BRACKET (x4)

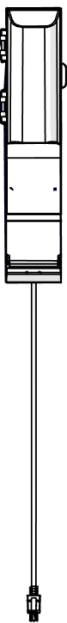

9205413 ELECTRICAL ENCLOSURE (x1)

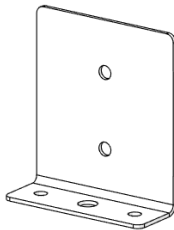

A4M00977 POST ANCHORING PLATE (x8)

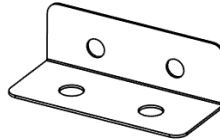

A4M04154 PURLIN SUPPORT BRACKET (x20)

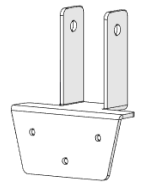

A4M05398 RAFTER CLIP (x8)

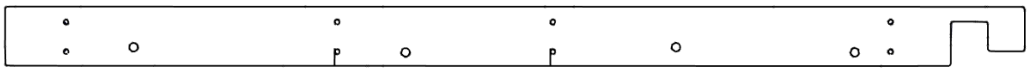

A4M04155 RIDGE PLATE (x1)

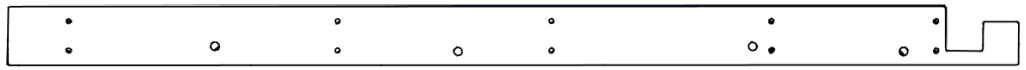

A4M04156 RIDGE PLATE (x1)

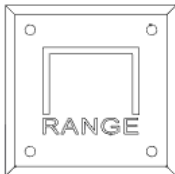

A4M07048 ID TAG RANGE (x1)

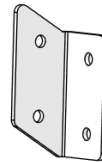

A4M04907 FASCIA BRACKET (x2)

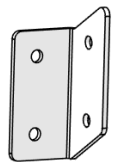

A4M04908 FASCIA BRACKET (x2)

OWNERS MANUAL - PARTS IDENTIFICATION

Metal Components (NOT TO SCALE)

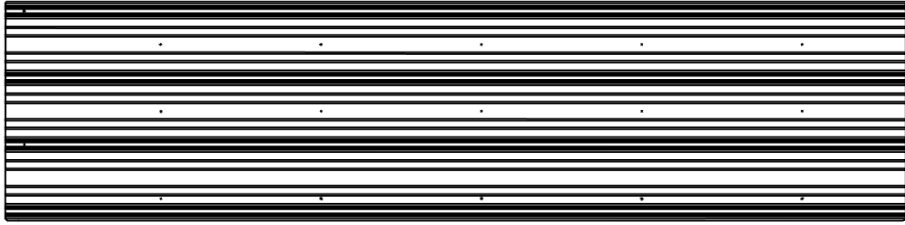

A4M04159 29GA STEEL SHEETING
(x6)



A4M04160 29GA STEEL SHEETING
(x4)

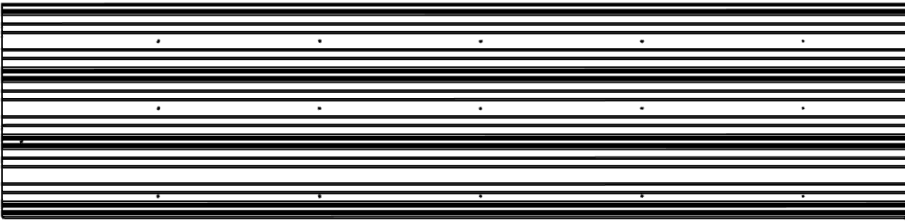

A4M04330 29GA STEEL SHEETING
(x1)

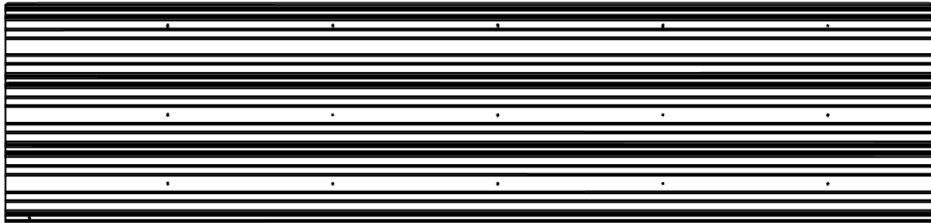

A4M05348 29GA STEEL SHEETING
(x1)

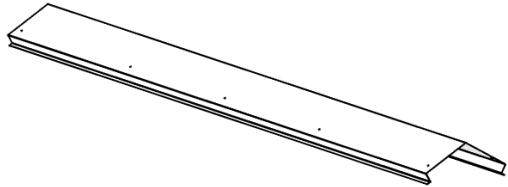

A4M04327 RIDGE CAP
(x2)

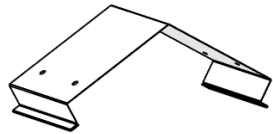

A4M04328 RIDGE CAP SPLICE
(x1)

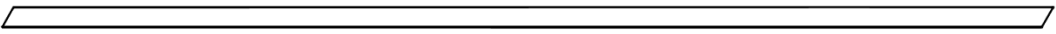

A4M04325 ROOF END TRIM
(x2)

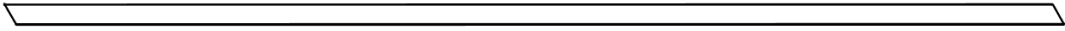

A4M04326 ROOF END TRIM
(x2)

OWNERS MANUAL - PARTS IDENTIFICATION

Metal Components (NOT TO SCALE)

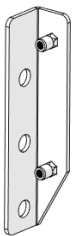

C01 ANGLE BRACE BRACKET - A4M04148
(x6) 1 1/16"x1 1/4"x6" (27x31x152)



R01 RAFTER SUPPORT BRACE - A4M04329
(x2) 1 9/16"x4 3/8"x60 1/8" (40x111x1527)

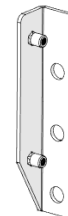

C02 ANGLE BRACE BRACKET - A4M04153
(x6) 1 1/16"x1 1/4"x6" (27x31x152)



C03 ANGLE BRACE - A4M04149
(x2) 1 1/2"x5 15/16"x27 1/16" (38x151x687)



C04 ANGLE BRACE - A4M04150
(x2) 1 1/2"x5 15/16"x27 1/16" (38x151x687)



B07 VERTICAL GABLE SUPPORT - A4M04317
(x2) 1 1/2"x9 1/16"x34 11/16" (38x230x882)



C05 ANGLE BRACE - A4M04320
(x2) 1 7/16"x5 5/16"x20 1/16" (36x135x509)



C06 ANGLE BRACE - A4M04321
(x2) 1 7/16"x5 5/16"x20 1/16" (36x135x509)

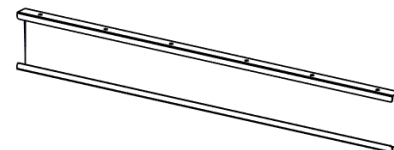

J1 SPLICE BRACKET - A4M02230
(x2) 1 5/16"x5 3/16"x39 3/8" (33.2x131.2x1000)



B01 GABLE BEAM - A4M04151
(x2) 1 9/16"x5 1/4"x1826 (39x134x1827)



B02 GABLE BEAM - A4M04152
(x2) 1 9/16"x5 1/4"x71 15/16" (39x134x1827)

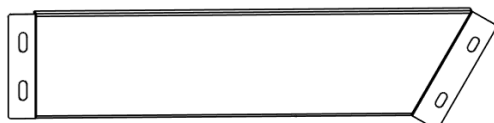

B08 GABLE SUPPORT - A4M04318
(x2) 1 1/2"x5 15/16"x24 5/8" (38x152x625)

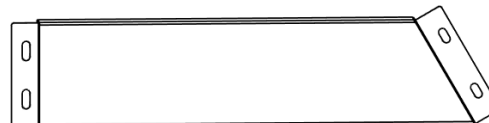

B09 GABLE SUPPORT - A4M04319
(x2) 1 1/2"x5 15/16"x24 5/8" (38x152x625)

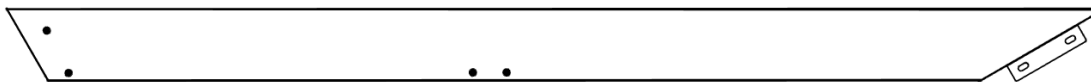

B03 GABLE BEAM - A4M04157
(x2) 1 1/2"x5 1/4"x79 1/2" (38x134x2019)



B04 GABLE BEAM - A4M04158
(x2) 1 1/2"x5 1/4"x79 1/2" (38x134x2019)

OWNER'S MANUAL - PARTS IDENTIFICATION

Hardware Components



H100972 BOLT WH BLK
(x52) 5/16x5-1/4

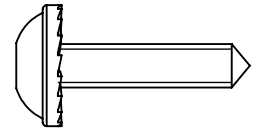

H100460 LAG SCREW WH BLK
(x40) 1/4x1

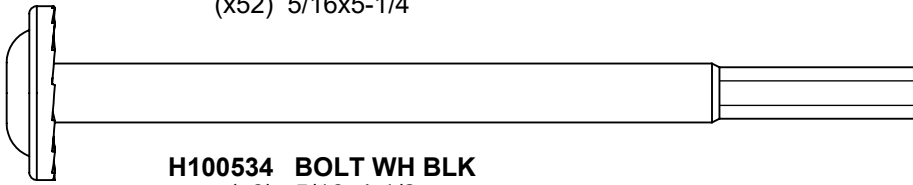

H100534 BOLT WH BLK
(x6) 5/16x4-1/2

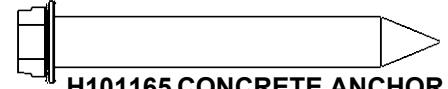

H101165 CONCRETE ANCHOR
(x16) 3/8x3 BLK



H100503 BOLT WH BLK
(x12) 5/16x3-1/2

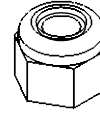

H100653 NUT LOCK BLK
(x12) 1/4

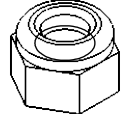

H100479 NUT LOCK BLK
(x28) 5/16

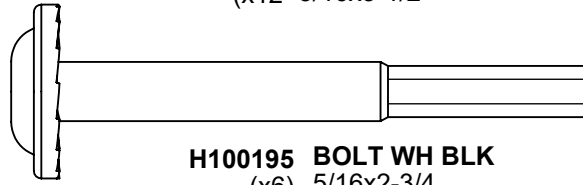

H100195 BOLT WH BLK
(x6) 5/16x2-3/4

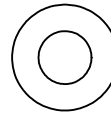

H101133 WASHER FLAT BLK
(x4) 7x14

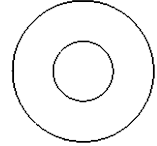

H100630 WASHER FLAT BLK
(x16) 8x19

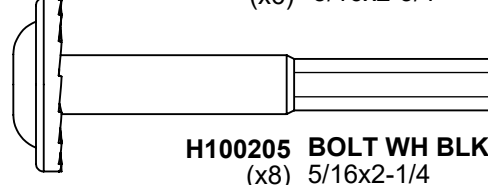

H100205 BOLT WH BLK
(x8) 5/16x2-1/4

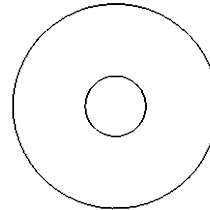

H100478 WASHER FLAT BLK
(x20) 8x27

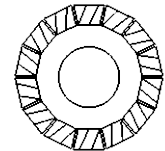

H100198 WASHER LOCK EXT BLK
(x22) 8x19

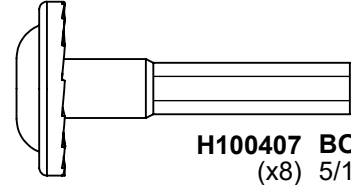

H100407 BOLT WH BLK
(x8) 5/16x1-1/2

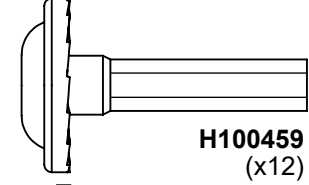

H100459 BOLT WH BLK
(x12) 5/16x1-1/4

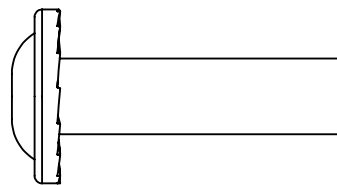

H100193 NUT BARREL WH BLK
(x52) 5/16x1-1/2

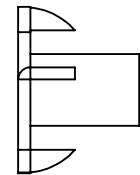

H100379 T-NUT BLK
(x24) 5/16

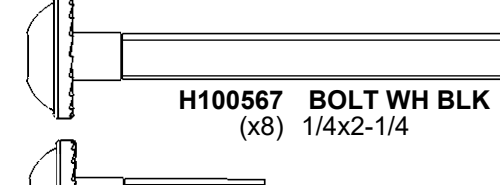

H100567 BOLT WH BLK
(x8) 1/4x2-1/4

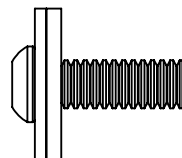

H101202 TORX PAN HEAD 1/4-20x3/4 ASSY
(x108) 1/4-20x3/4

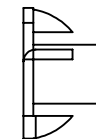

H100398 T-NUT BLK
(x40) 1/4

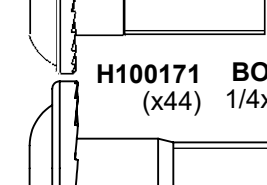

H100171 BOLT WH BLK
(x44) 1/4x1

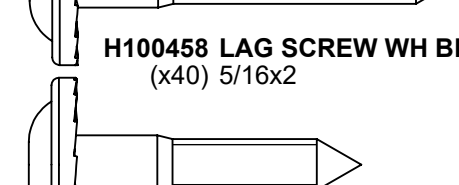

H100458 LAG SCREW WH BLK
(x40) 5/16x2

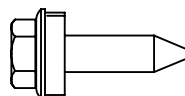

H101117 SCREW WOODGRIP BLK
(x220) 10x3/4

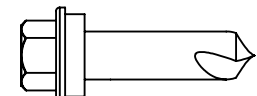

H101116 SCREW SELF TAPPING BLK
(x20) 1/4 x 1



H100471 LAG SCREW WH BLK
(x48) 5/16x1-1/2

OWNER'S MANUAL - PARTS IDENTIFICATION

Hardware Components



H100201 | SCREW PFH BLK
(x32) | 8x2-1/2



H100391 | SCREW PFH BLK
(x196) | 8x2

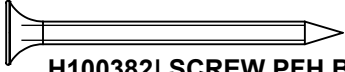

H100382 | SCREW PFH BLK
(x18) | 8x1-3/4

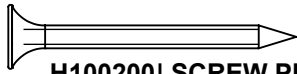

H100200 | SCREW PFH BLK
(x16) | 8x1-1/2

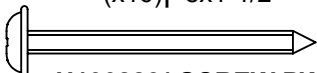

H100823 | SCREW PWH BLK
(x24) | 8x1-1/2

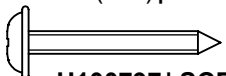

H100797 | SCREW PWH BLK
(x16) | 8x1

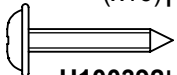

H100392 | SCREW PWH BLK
(x16) | 8x3/4

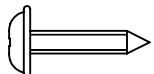

H100202 | SCREW PWH BLK
(x4) | 8x5/8

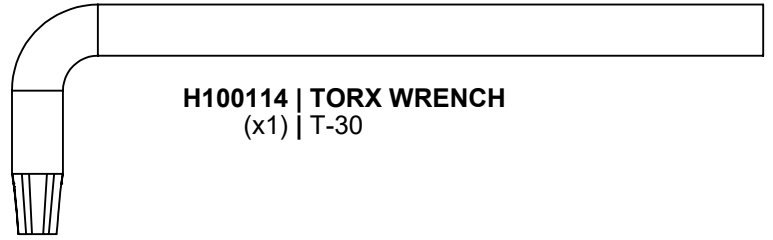

H100114 | TORX WRENCH
(x1) | T-30

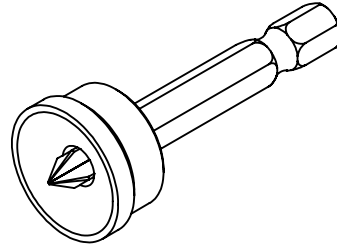

H100764 | SCREW SETTER
(x1) |

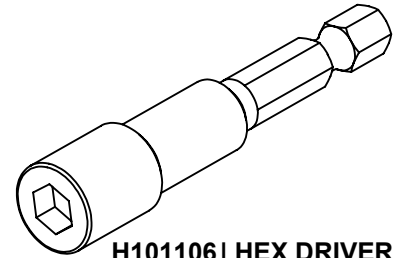

H101106 | HEX DRIVER
(x1) | 5/16

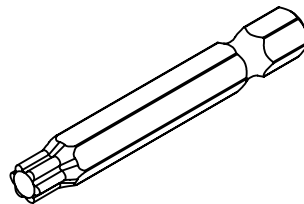

H100147 | TORX BIT
(x1) | T-30 T-30

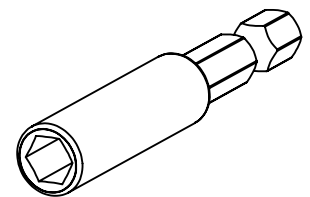

H101100 | MAGNETIC DRIVER
(x1) |

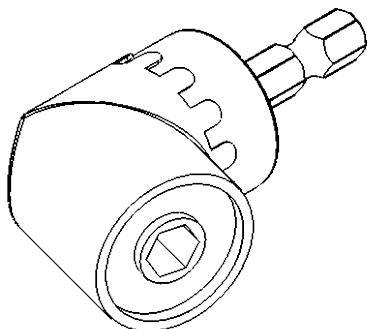

**H101114 | RIGHT ANGLE DRILL
ADAPTER**
(x1) |

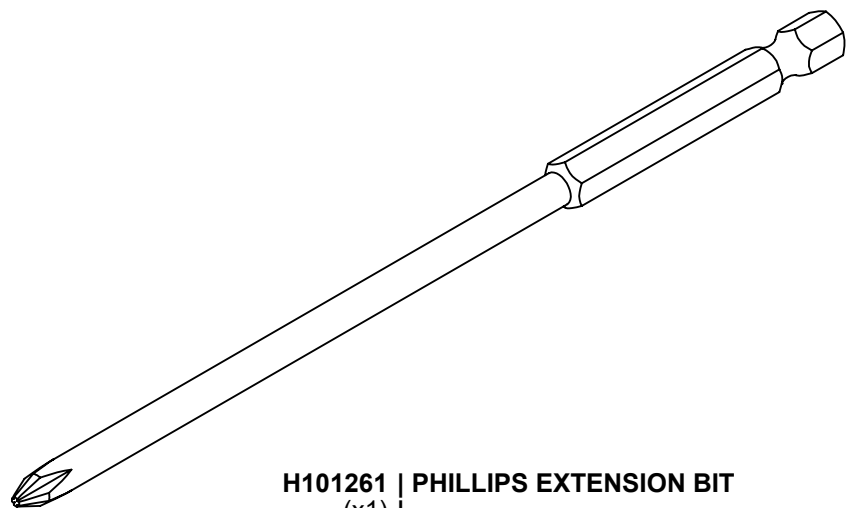

H101261 | PHILLIPS EXTENSION BIT
(x1) |

PRE-ASSEMBLY STEP 1 - SORTING WOOD PARTS

It is critical for ease of assembly that you take the time to sort and organize the wood and hardware.

WOOD PARTS:

- Organize wood parts by the three-digit, alpha-numeric number stamped on each board (ex. P01).
- If there are multiple boards with the same stamped number, stack those pieces together.
- Stamps can be found on the flat surface of the boards or on the end of the boards.
- Allow yourself plenty of room - the wood pieces can take up a significant amount of space.

NOTE: CARTONS ARE NOT ORGANIZED BY BOARD NUMBER.



HARDWARE PARTS:

- We recommend that you have a separate table to organize the hardware.
- Hardware bags are printed with a seven-digit, alpha-numeric part number.
- You can organize your hardware by part number or group by hardware type (i.e. bolts, nuts, etc.).
- During assembly you only need to reference the last four digits of the number.

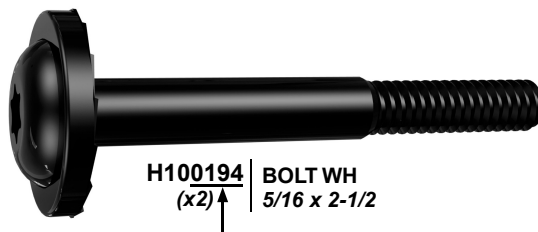

PRE-ASSEMBLY STEP 2 - TOOLS REQUIRED



Cordless Drill
or Electric Drill



Drill
Attachments:
Phillips Head

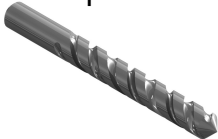

1/8", 3/16", 3/8" &
7/16" Drill Bits

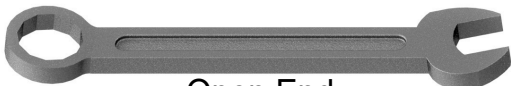

Open End
Wrenches 1/2" &
9/16"



3/8" Drive Ratchet, 1/2" &
7/16" STD Sockets 1/2" & 7/16"
Deep Sockets



Phillips Screw Driver



Claw Hammer



Rubber Mallet
- Optional

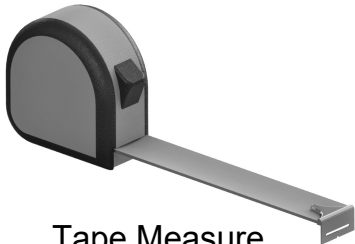

Tape Measure

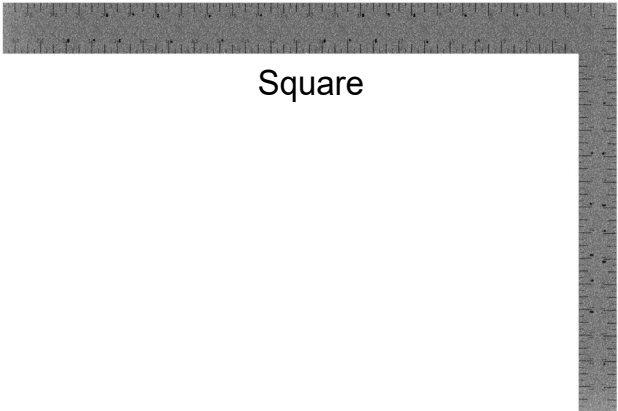

Square



Level 24"



8 FOOT LADDER REQUIRED

PRE-ASSEMBLY STEP 3 - CHOOSE YOUR ASSEMBLY METHOD

There are several types of assembly instructions available to you.

1. Printed Assembly Manual included with your set
2. BILT APP - 3D interactive instructions
3. Combination of the Printed Manual and BILT APP (Note: Step numbers can differ between the two methods)



BILT.

Scan for easy
3D instructions

Download the BILT app
before you begin

Download on the
App Store

GET IT ON
Google Play

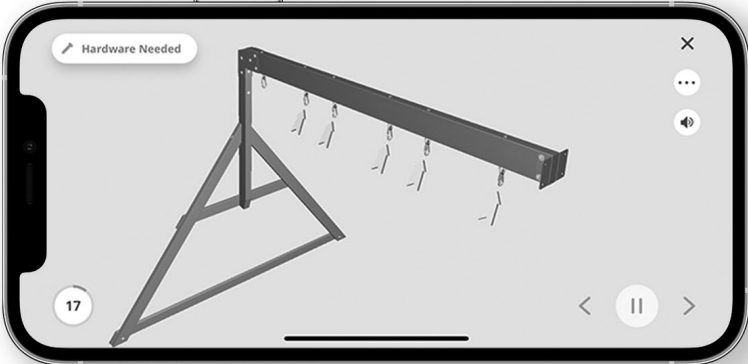

The image shows a smartphone screen displaying the BILT app interface. The screen features a 3D assembly diagram of a metal frame. At the top left, there is a button labeled "Hardware Needed". At the bottom left, a circular icon contains the number "17". At the bottom right, there are navigation icons: a back arrow, a pause button, and a forward arrow. The app interface is clean and modern, with a white background and grey accents.

STEP 1 - POST ASSEMBLY

QTY	PART NUMBER	DESCRIPTION
16	H100200	SCREW PFH 8x1 1/2 BLK

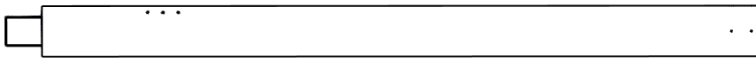

P01 POST - W2A04544
(x2) 6"X6"X89 3/8" (152x152x2270)

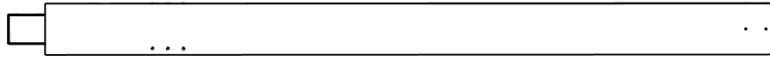

P02 POST - W2A04545
(x2) 6"X6"X89 3/8" (152x152x2270)

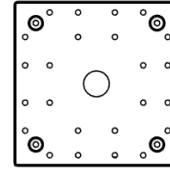

A6P00308 6x6 POST FOOT
(x4)

- FOR EASE OF ASSEMBLY, WE RECOMMEND USING SAWHORSES FOR STEPS 1 THROUGH 7.

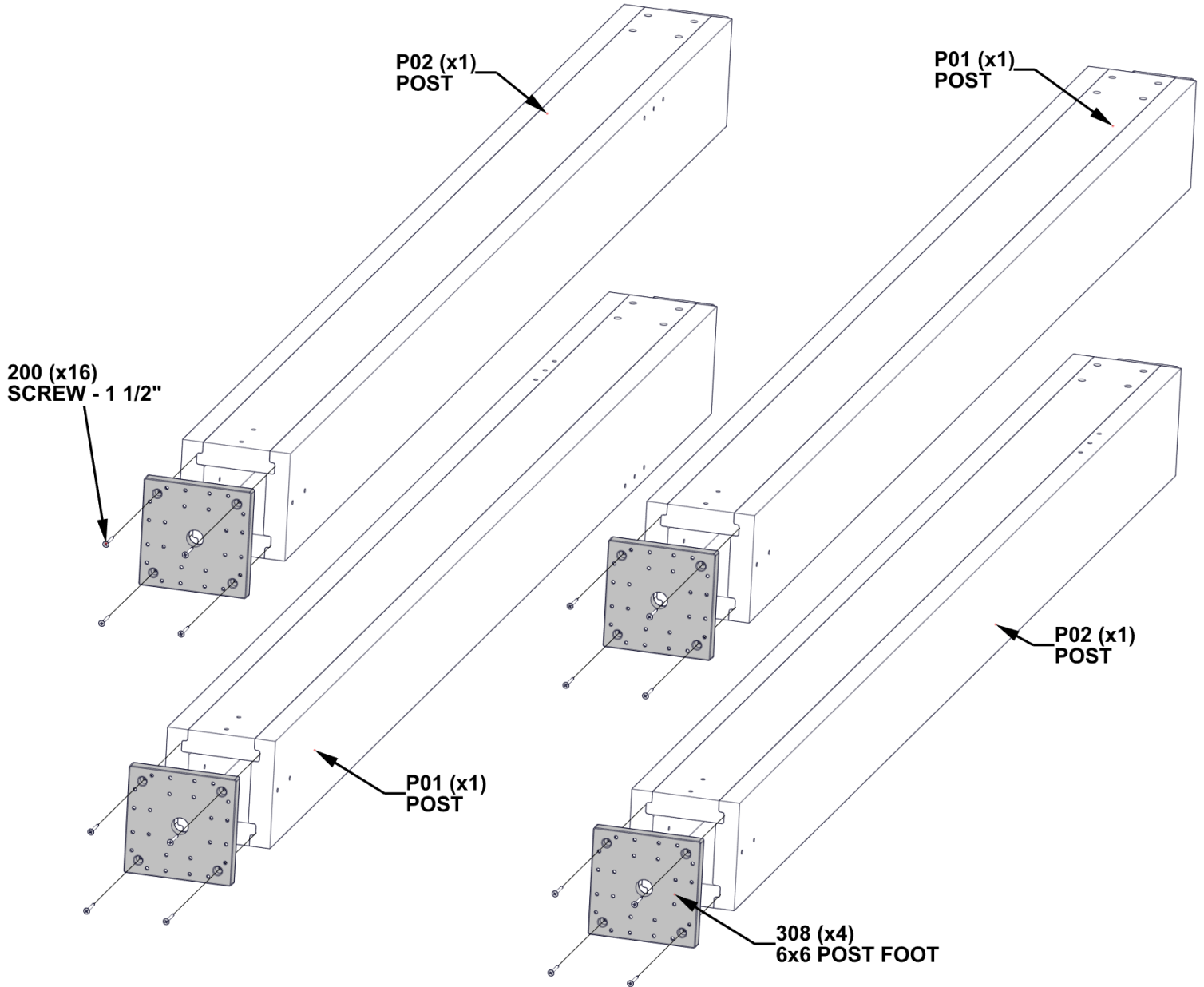

CENTER POST FOOT AND DRILL 1/8" (3mm) PILOT HOLES FOR THE ATTACHMENT OF HARDWARE.

STEP 2 - BEAM ASSEMBLY

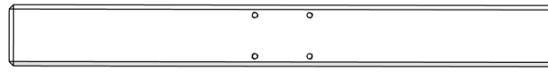

BS01 BEAM SPLICE - W4L21556
(x1) 3 3/8"X4 3/8"X39 3/8" (87x112x1000)

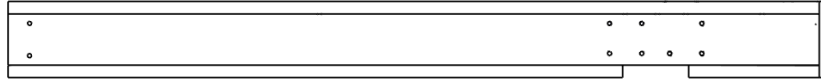

P03 BEAM - W2A04479
(X1) 6"x6 15/16"x75 3/8" (152x177x1914)

- SLIDE BS01 SPLICE INSIDE P03 BEAM AND ALIGN HOLES CIRCLED IN RED.
- RUBBER Mallet MAY NEED TO BE USED TO TAP PARTS IN PLACE.

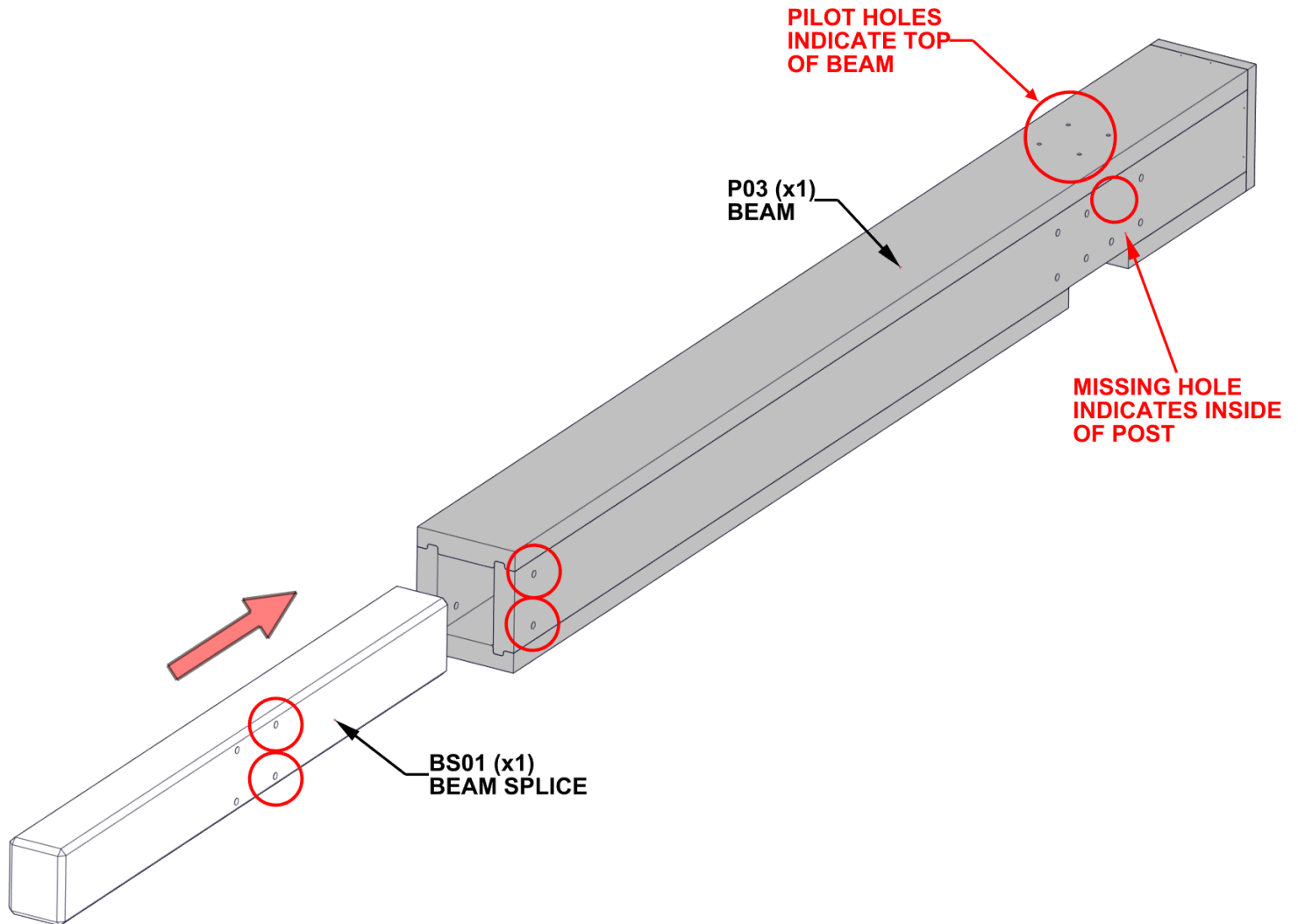

STEP 3 - BEAM ASSEMBLY

QTY	PART NUMBER	DESCRIPTION
2	H100193	NUT BARREL WH 5/16 X 1 1/2 BLK
2	H100972	BOLT WH 5/16x5 1/4 BLK

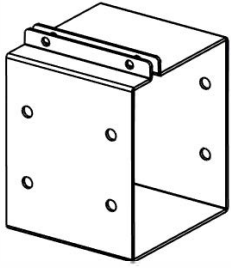

A4M04909 BEAM BAND
(x1)

- LEAVE 363 BOLTS AND 192 BARREL NUTS HAND TIGHTENED.

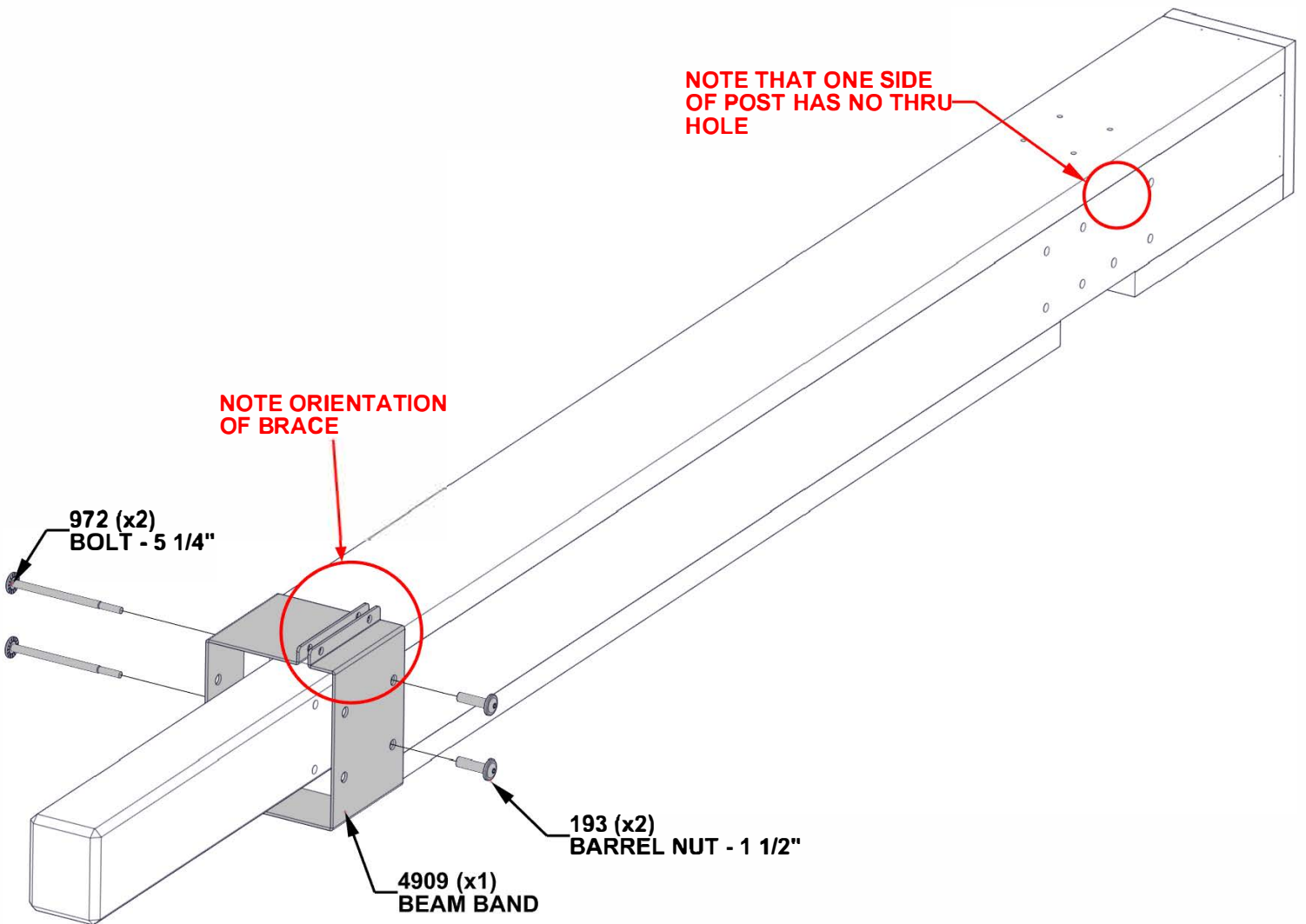

STEP 4 - BEAM ASSEMBLY

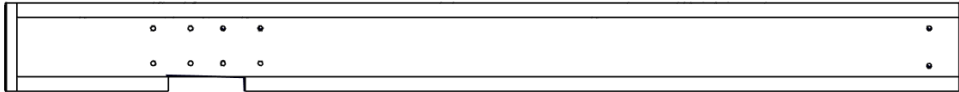

P04 BEAM - W2A04480
(x1) 6"x6 15/16"x75 3/8" (152x177x1914)

- SLIDE P04 OVER BEAM SPLICE AND ALIGN HOLES IN BEAM BAND AND BEAM SPLICE.

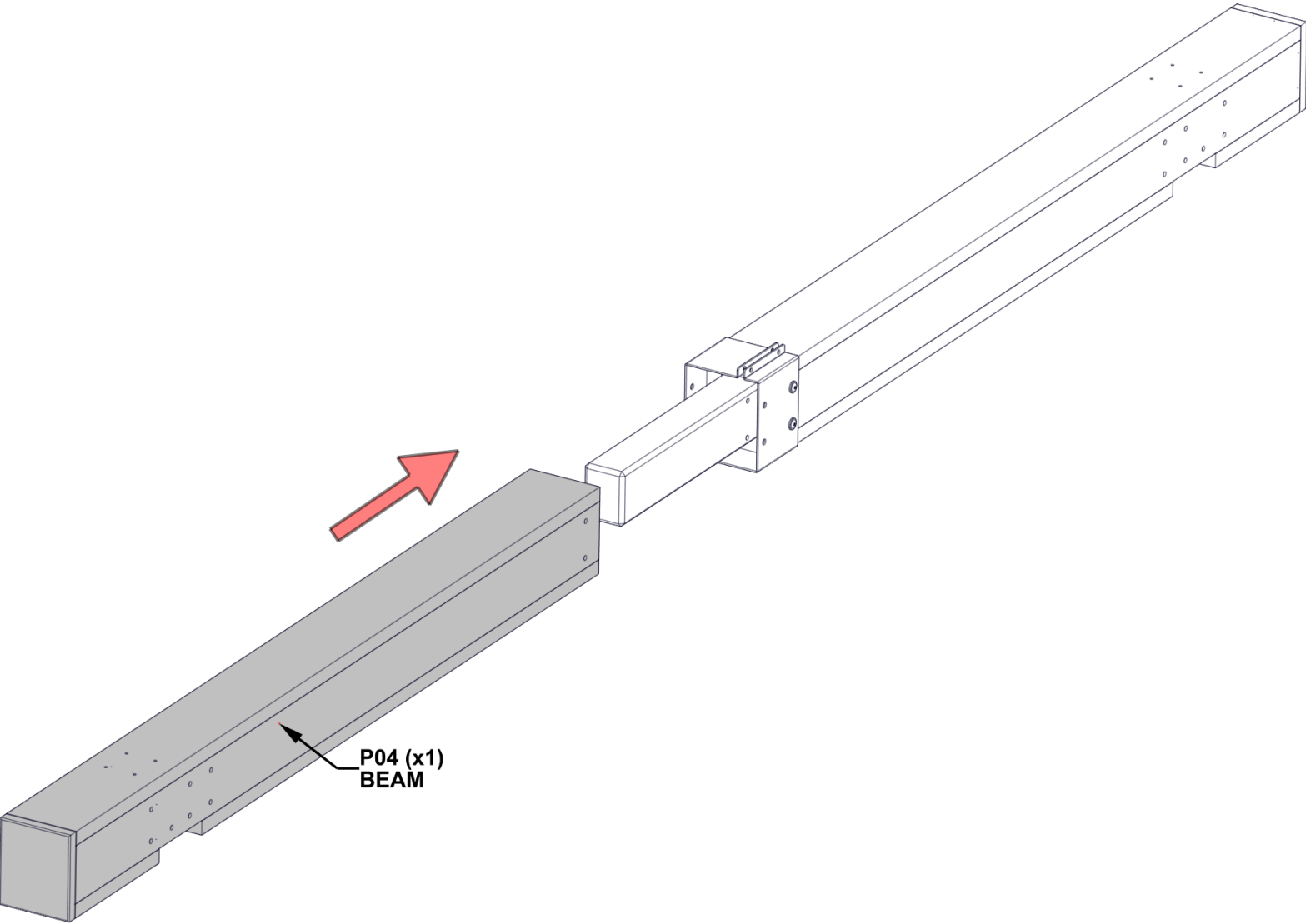

STEP 5 - BEAM ASSEMBLY

QTY	PART NUMBER	DESCRIPTION
2	H100193	NUT BARREL WH 5/16 X 1 1/2 BLK
2	H100972	BOLT WH 5/16x5 1/4 BLK

- LEAVE 972 BOLTS AND 193 BARREL NUTS HAND TIGHTENED.

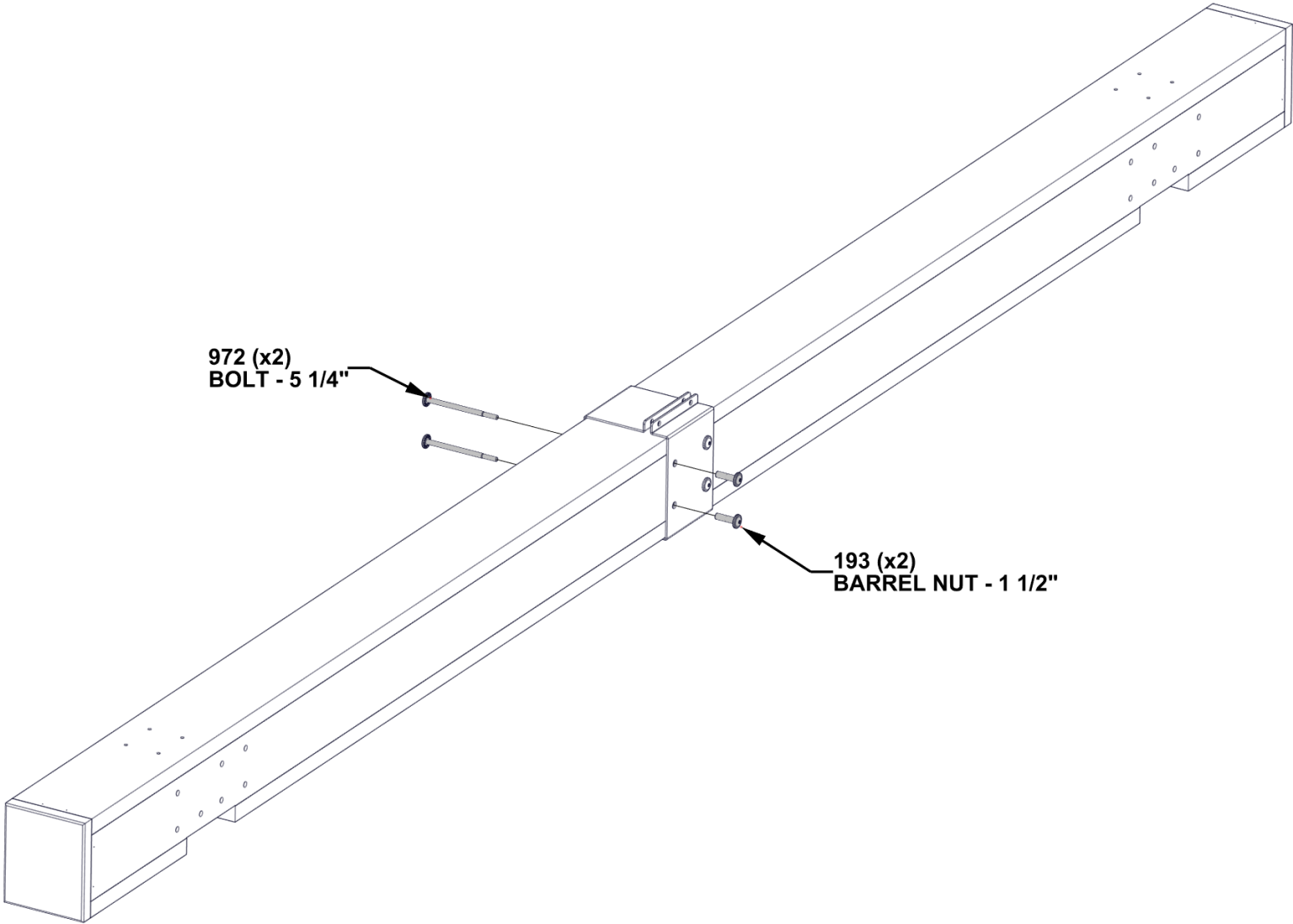

STEP 6 - BEAM ASSEMBLY

QTY	PART NUMBER	DESCRIPTION
2	H100171	BOLT WH 1/4x1 BLK
2	H100653	NUT LOCK 1/4 BLK
2	H101133	WASHER FLAT 7x14 BLK

- AFTER HARDWARE HAS BEEN ATTACHED, FULLY TIGHTEN HARDWARE.

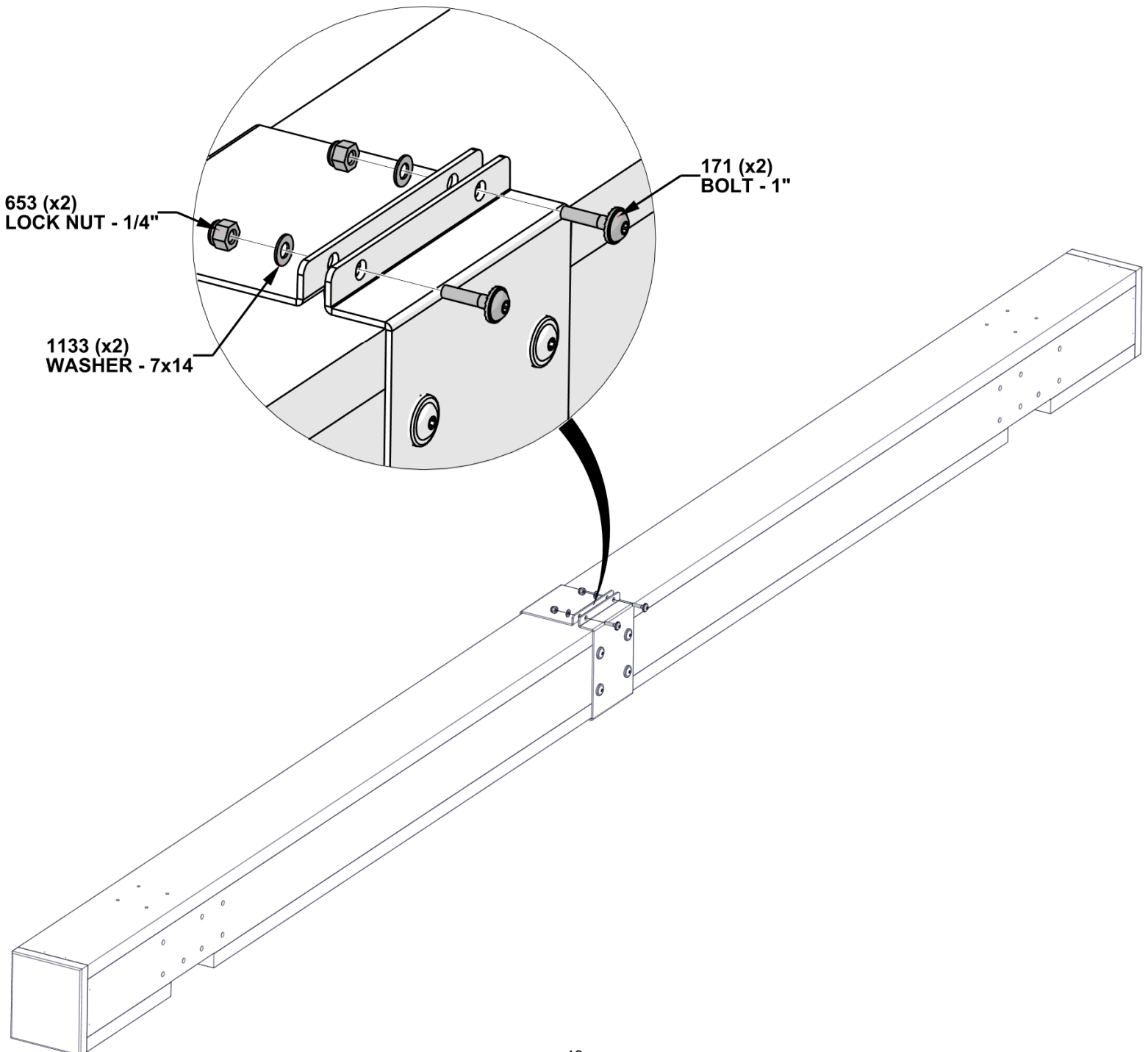

STEP 7 - BEAM ASSEMBLY

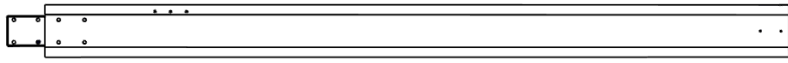

P01 POST ASSEMBLY FROM STEP 1

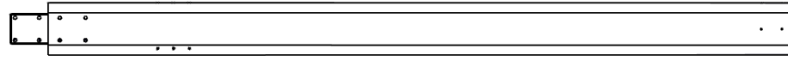

P02 POST ASSEMBLY FROM STEP 1

- SLIDE P01 AND P02 POSTS INTO BEAM ASSEMBLY AS SHOWN.

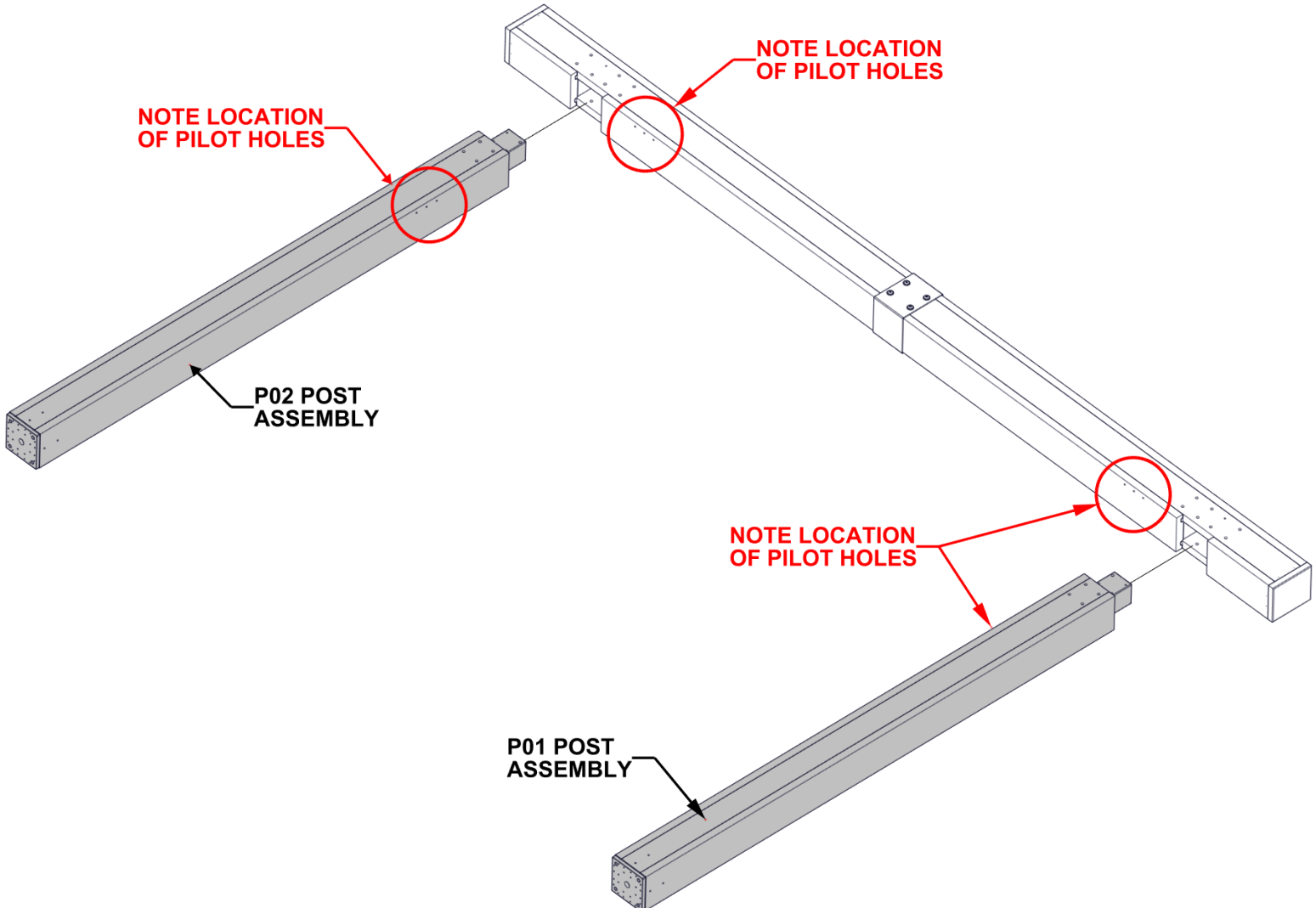

STEP 8 - BEAM ASSEMBLY

QTY	PART NUMBER	DESCRIPTION
14	H100193	NUT BARREL WH 5/16 X 1 1/2 BLK
14	H100972	BOLT WH 5/16x5 1/4 BLK

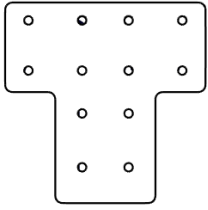

A4M04104 POST SUPPORT BRACKET
(x2)

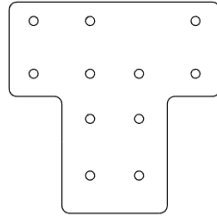

A4M04906 POST SUPPORT BRACKET
(x2)

- HAND TIGHTEN ONLY.

- NOTE ORIENTATION OF BRACKETS, 4906 BRACKET GOES TOWARD THE INSIDE OF POSTS.

- IF HOLES DO NOT ALIGN, USE A 7/16" [10mm] DRILL BIT AND THE METAL BRACKET AS A GUIDE TO DRILL THROUGH THE BOARDS.

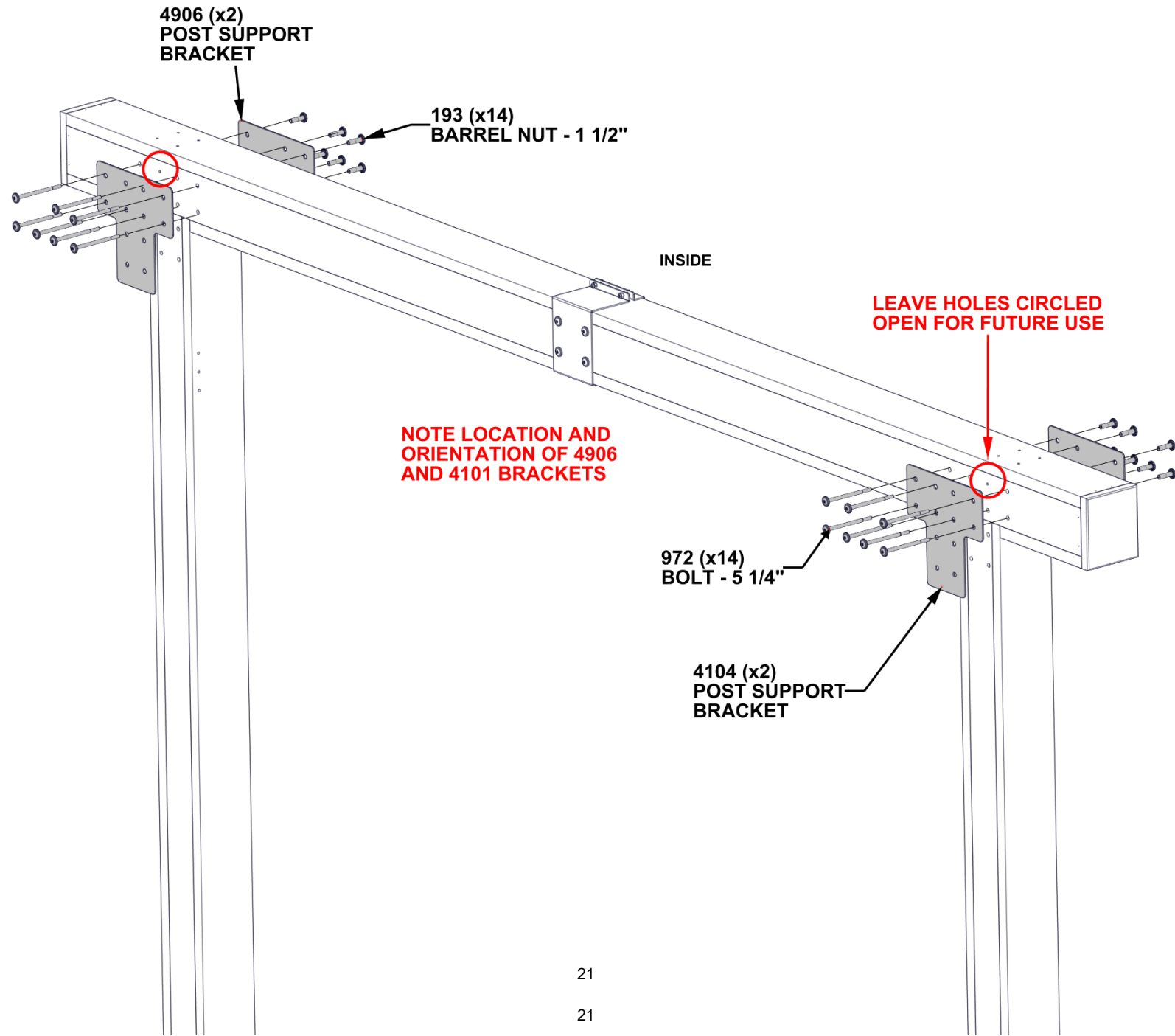

STEP 9 - BEAM ASSEMBLY

QTY	PART NUMBER	DESCRIPTION
8	H100193	NUT BARREL WH 5/16 X 1 1/2 BLK
2	H100458	LAG SCREW WH 5/16x2 BLK
8	H100972	BOLT WH 5/16x5 1/4 BLK

- HAND TIGHTEN ONLY.

- AFTER HARDWARE IS INSTALLED, FULLY TIGHTEN HARDWARE.
- IF HOLES DO NOT ALIGN, USE A 7/16" [10mm] DRILL BIT AND THE METAL BRACKET AS A GUIDE TO DRILL THROUGH THE BOARDS.

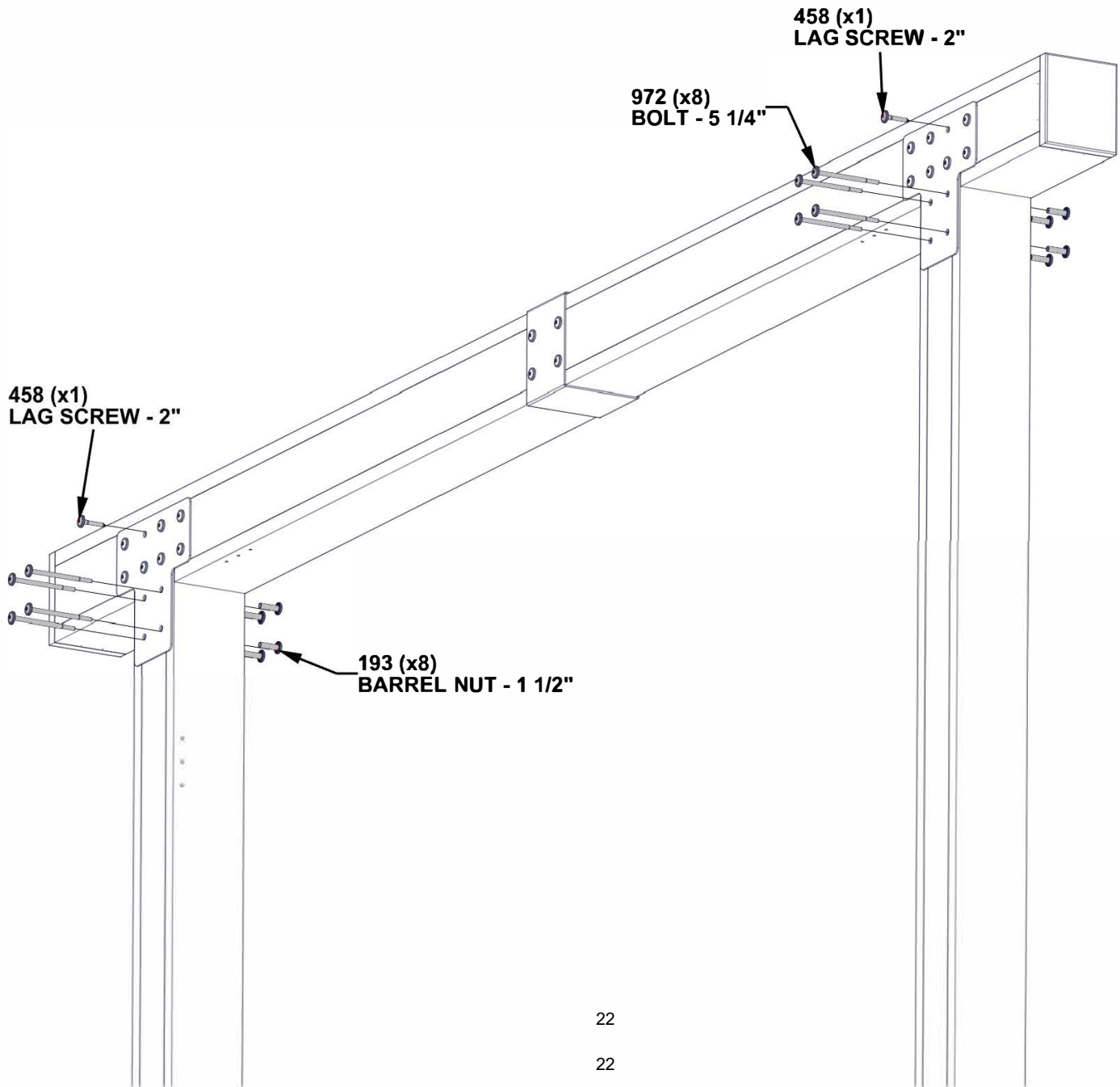

STEP 10 - BEAM ASSEMBLY

QTY	PART NUMBER	DESCRIPTION
8	H100471	LAG SCREW WH 5/16x1 1/2 BLK

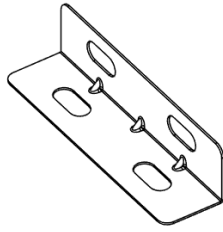

A4M04324 GABLE BEAM BRACE
(x4)

- HAND TIGHTEN HARDWARE.

- NOTE ORIENTATION OF BRACE MOUNTED TO TOP SIDE OF BEAM ASSEMBLY.
- AFTER BRACES HAVE BEEN INSTALLED, STAND ASSEMBLY UP AND SET ASIDE.

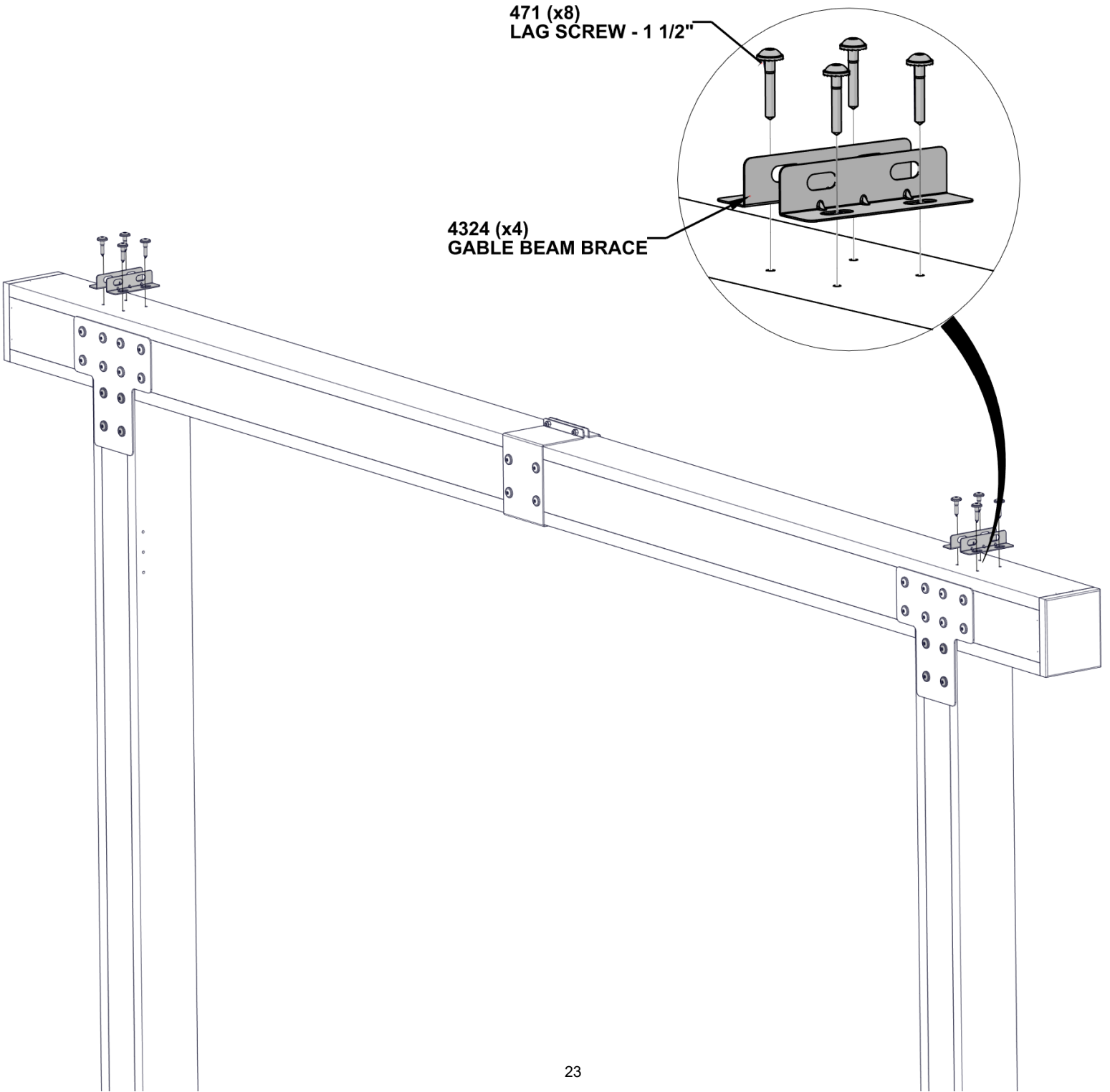

471 (x8)
LAG SCREW - 1 1/2"

4324 (x4)
GABLE BEAM BRACE

**REPEAT POST AND BEAM ASSEMBLY
STEPS 2 THROUGH 10**

STEP 11 - GABLE ASSEMBLY

QTY	PART NUMBER	DESCRIPTION
10	H101202	TORX PAN HEAD 1/4-20x3/4 ASSY

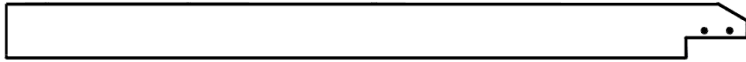

B01 GABLE BEAM - A4M04151
(x1) 1 9/16"x5 1/4"x1826 (39x134x1827)

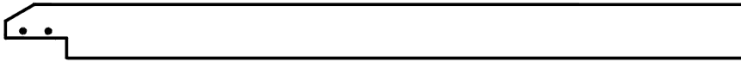

B02 GABLE BEAM - A4M04152
(x1) 1 9/16"x5 1/4"x71 15/16" (39x134x1827)



J1 SPLICE BRACKET - A4M02230
(x2) 1 5/16"x5 3/16"x39 3/8" (33.2x131.2x1000)

- HAND TIGHTEN HARDWARE.
- NOTE ORIENTATION OF J1 SPLICE BRACKET.
- SLIDE J1 SPLICE BRACKET INTO THE GABLE BEAMS AS SHOWN.
- ALIGN PILOT HOLES AND ATTACH WITH HARDWARE PROVIDED.

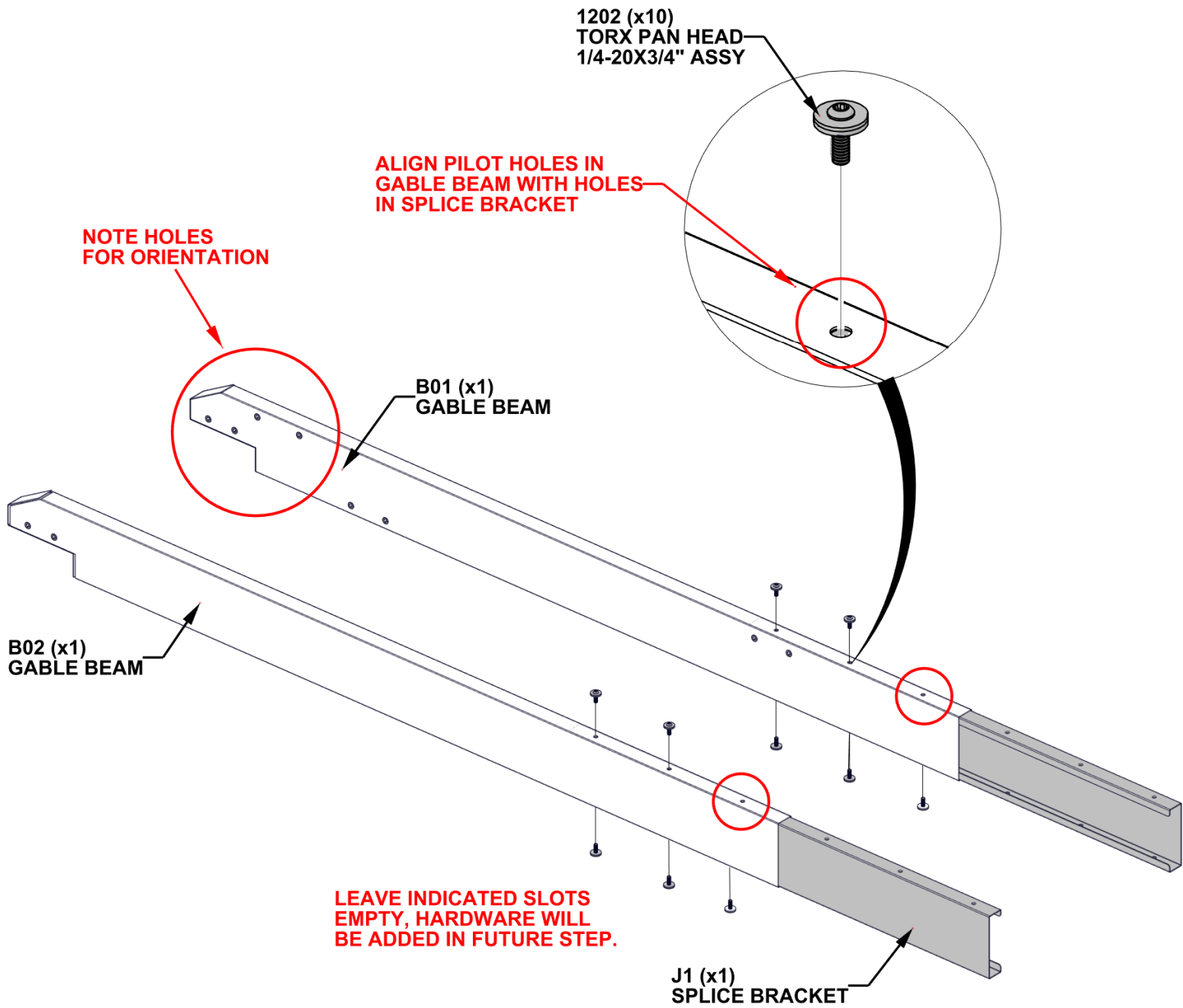

STEP 12 - GABLE ASSEMBLY

QTY	PART NUMBER	DESCRIPTION
10	H101202	TORX PAN HEAD 1/4-20x3/4 ASSY

B01 GABLE BEAM - A4M04151
(x1) 1 9/16"x5 1/4"x1826 (39x134x1827)

B02 GABLE BEAM - A4M04152
(x1) 1 9/16"x5 1/4"x71 15/16" (39x134x1827)

- SLIDE GABLE BEAMS B01 AND B02 OVER J1 SPLICE BRACKET.
- ALIGN PILOT HOLES AND ATTACH WITH HARDWARE PROVIDED.
- AFTER HARDWARE HAS BEEN INSERTED, FULLY TIGHTEN HARDWARE.

1202 (x10)
TORX PAN HEAD
1/4-20x3/4 ASSY

ALIGN PILOT HOLES WITH
HOLES IN SPLICE BRACE

B02 (x1)
GABLE BEAM

LEAVE INDICATED SLOTS
EMPTY, HARDWARE WILL
BE ADDED IN FUTURE STEP.

B01 (x1)
GABLE BEAM

STEP 13 - FRAME ASSEMBLY

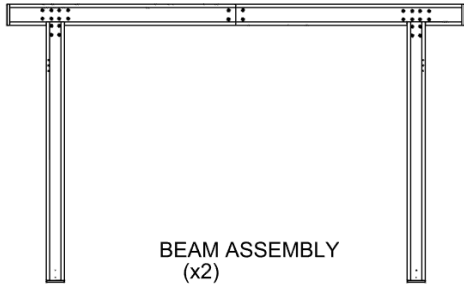

BEAM ASSEMBLY
(x2)

QTY	PART NUMBER	DESCRIPTION
16	H101202	TORX PAN HEAD 1/4-20x3/4 ASSY

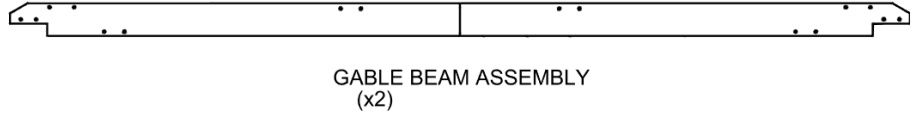

GABLE BEAM ASSEMBLY
(x2)

- **HAND TIGHTEN HARDWARE.**
- ADDITIONAL PEOPLE MAY BE HELPFUL FOR THIS STEP.

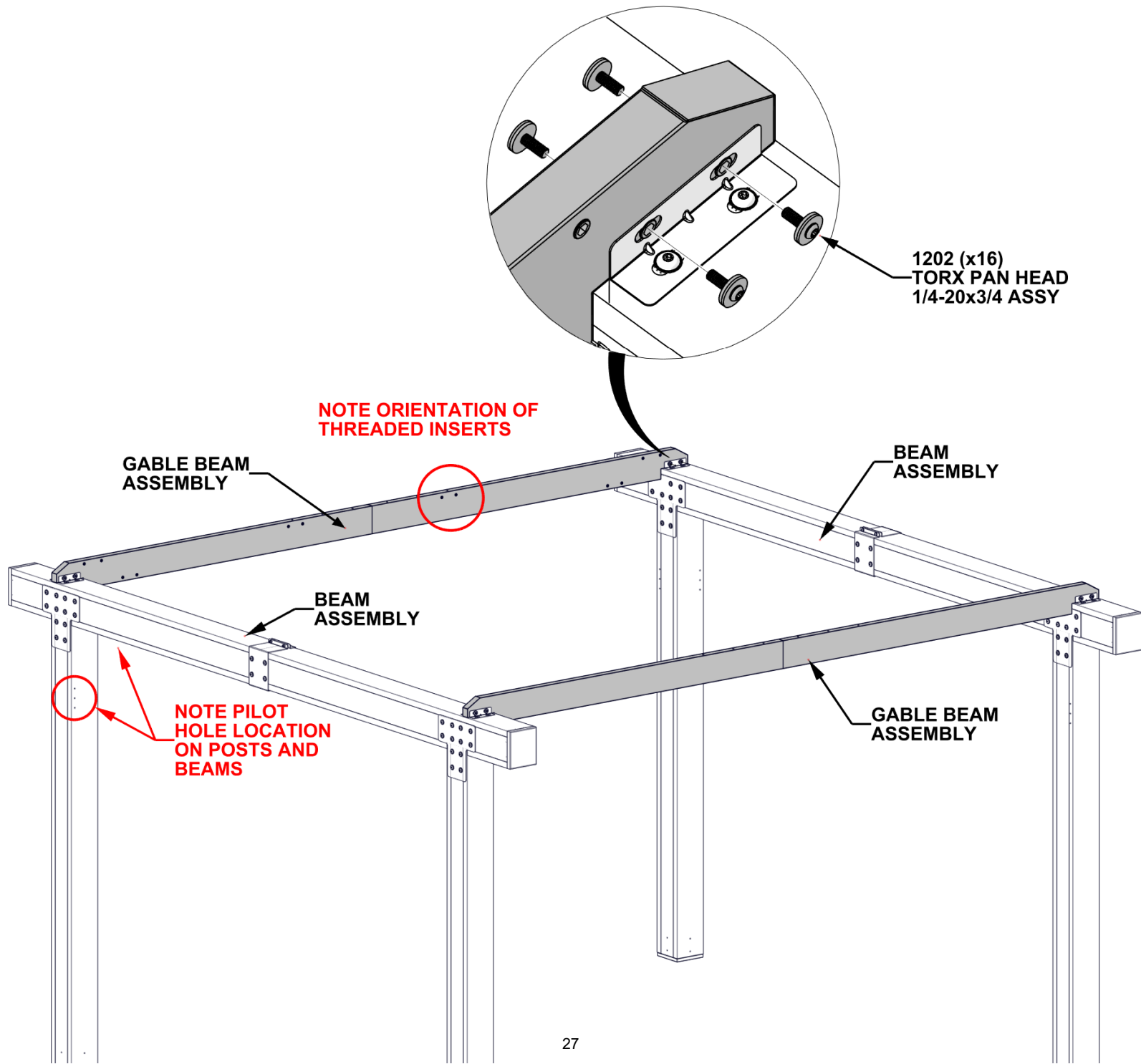

STEP 14 - FRAME ASSEMBLY

CRITICAL:

- SQUARE UNIT BEFORE PROCEEDING TO NEXT STEPS.
- THE BELOW DIMENSIONS ARE CIRITICAL TO THE FINAL ASSEMBLY.
- MEASUREMENTS SHOULD BE WITHIN +/- 1/4" (6mm).
- MEASUREMENTS OUTSIDE OF TOLERANCE WILL LEAD TO ISSUES ON FUTURE ASSEMBLY STEPS.
- AFTER UNIT HAS BEEN SQUARED, COMPLETELY TIGHTEN HARDWARE.



STEP 15 - CORBEL ASSEMBLY

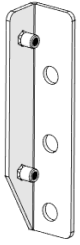

QTY	PART NUMBER	DESCRIPTION
12	H100458	LAG SCREW WH 5/16x2 BLK

C02 ANGLE BRACE BRACKET - A4M04153
(x2) 1 1/16"x1 1/4"x6" (27x31x152)

C01 ANGLE BRACE BRACKET - A4M04148
(x2) 1 1/16"x1 1/4"x6" (27x31x152)

- ALIGN BRACKET WITH PILOT HOLES IN POST AND FOLLOW MEASUREMENTS AS SHOWN.

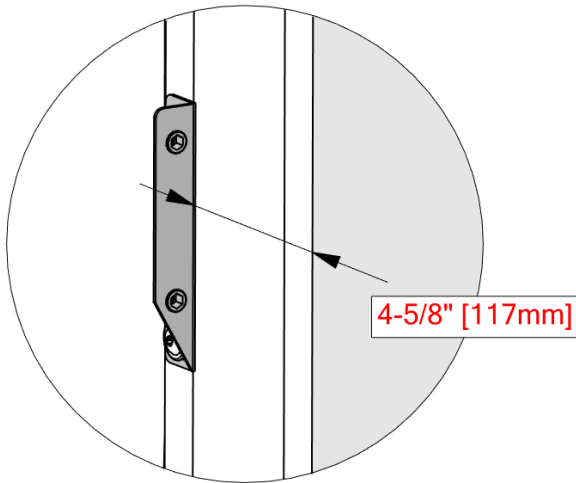

458 (x12)
LAG SCREW - 2"

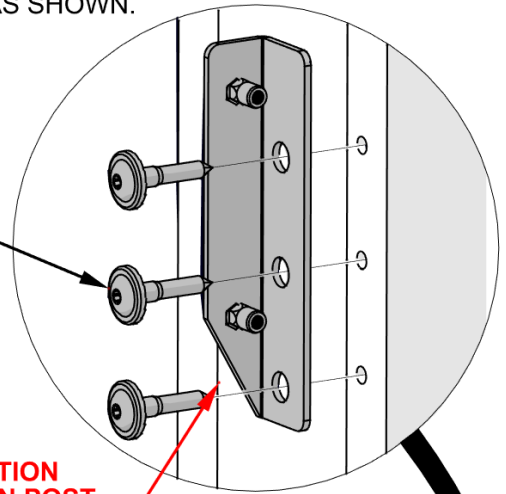

**NOTE ORIENTATION
OF BRACKET ON POST.
THE ANGLED PORTION
FACES DOWN.**

**HAND TIGHTEN BRACKET, MEASURE FROM
THE INSIDE OF THE POST TO BRACKET AS
SHOWN. THIS MEASUREMENT SHOULD BE
4-5/8" [117mm].**

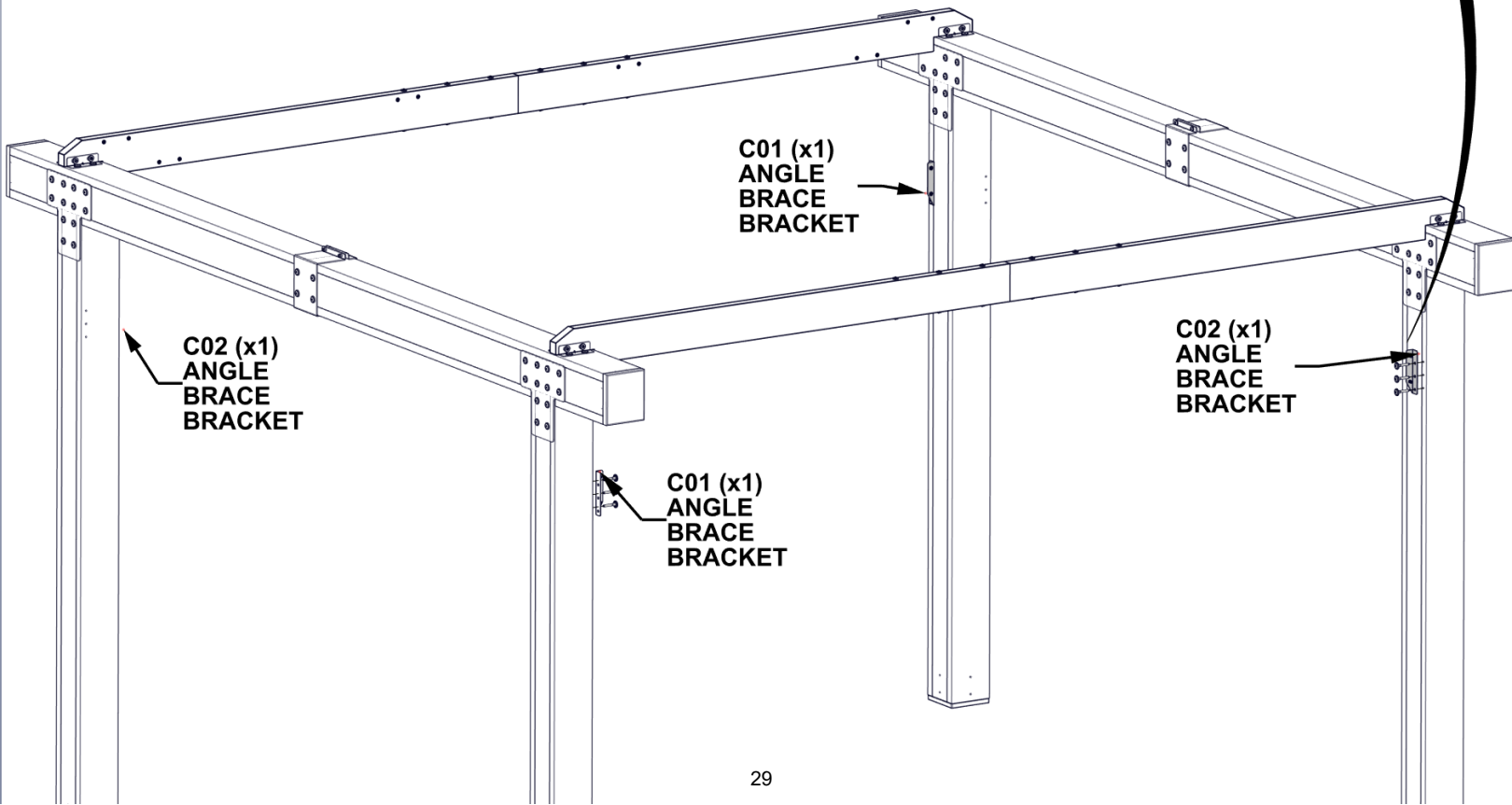

STEP 16 - CORBEL ASSEMBLY

QTY	PART NUMBER	DESCRIPTION
16	H101202	TORX PAN HEAD 1/4-20x3/4" ASSY



C03 ANGLE BRACE - A4M04149
(x2) 1 1/2"x5 15/16"x27 1/16" (38x151x687)



C04 ANGLE BRACE - A4M04150
(x2) 1 1/2"x5 15/16"x27 1/16" (38x151x687)

- **HAND TIGHTEN UNTIL ALL HARDWARE IS INSERTED, THEN FULLY TIGHTEN.**
- ALIGN ANGLE BRACE WITH THEADED INSERTS AS SHOWN BELOW.

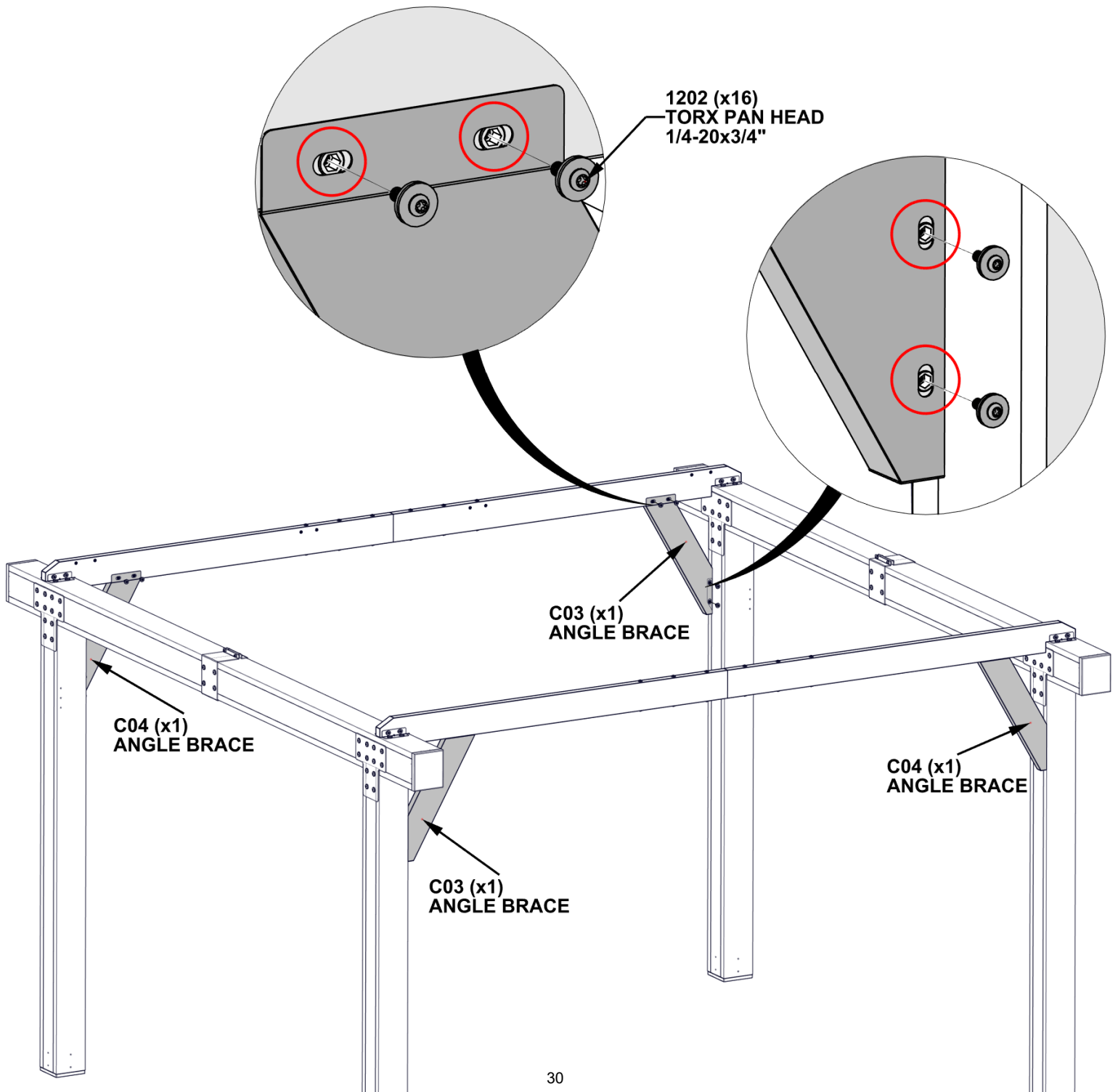

STEP 17 - CORBEL ASSEMBLY

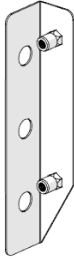
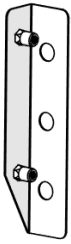

QTY	PART NUMBER	DESCRIPTION
12	H100458	LAG SCREW WH 5/16x2 BLK

C02 ANGLE BRACE BRACKET - A4M04153
(x2) 1 1/16"x1 1/4"x6" (27x31x152)

C01 ANGLE BRACE BRACKET - A4M04148
(x2) 1 1/16"x1 1/4"x6" (27x31x152)

- MEASURE 4-5/8" [117mm] FROM THE INSIDE OF THE POST TO THE BRACKET.

- ALIGN BRACKET WITH PILOT HOLES AS SHOWN.

C01 (x1)
ANGLE BRACE BRACKET

458 (x12)
LAG SCREW - 2"

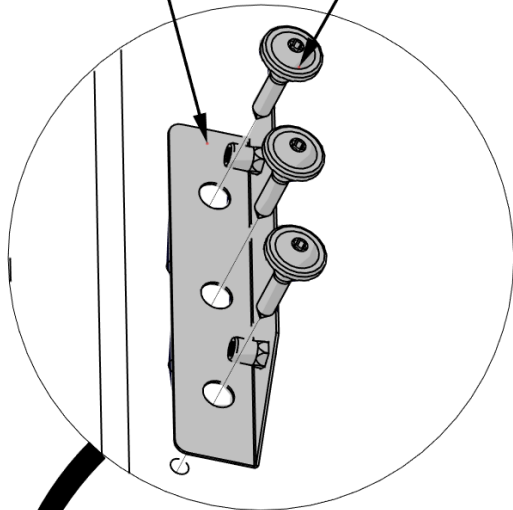

C02 (x1)
ANGLE BRACE BRACKET

**NOTE ORIENTATION
OF BRACKET ON POST.
THE ANGLED PORTION
FACES AWAY FROM CORNER
OF BEAM/POST ASSEMBLY.**

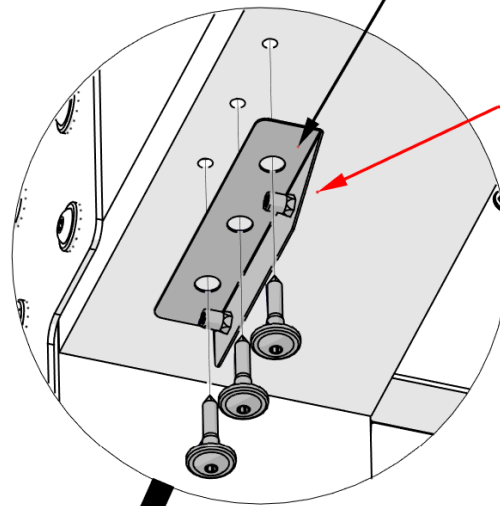

C01 (x1)
ANGLE BRACE
BRACKET

C02 (x1)
ANGLE BRACE
BRACKET

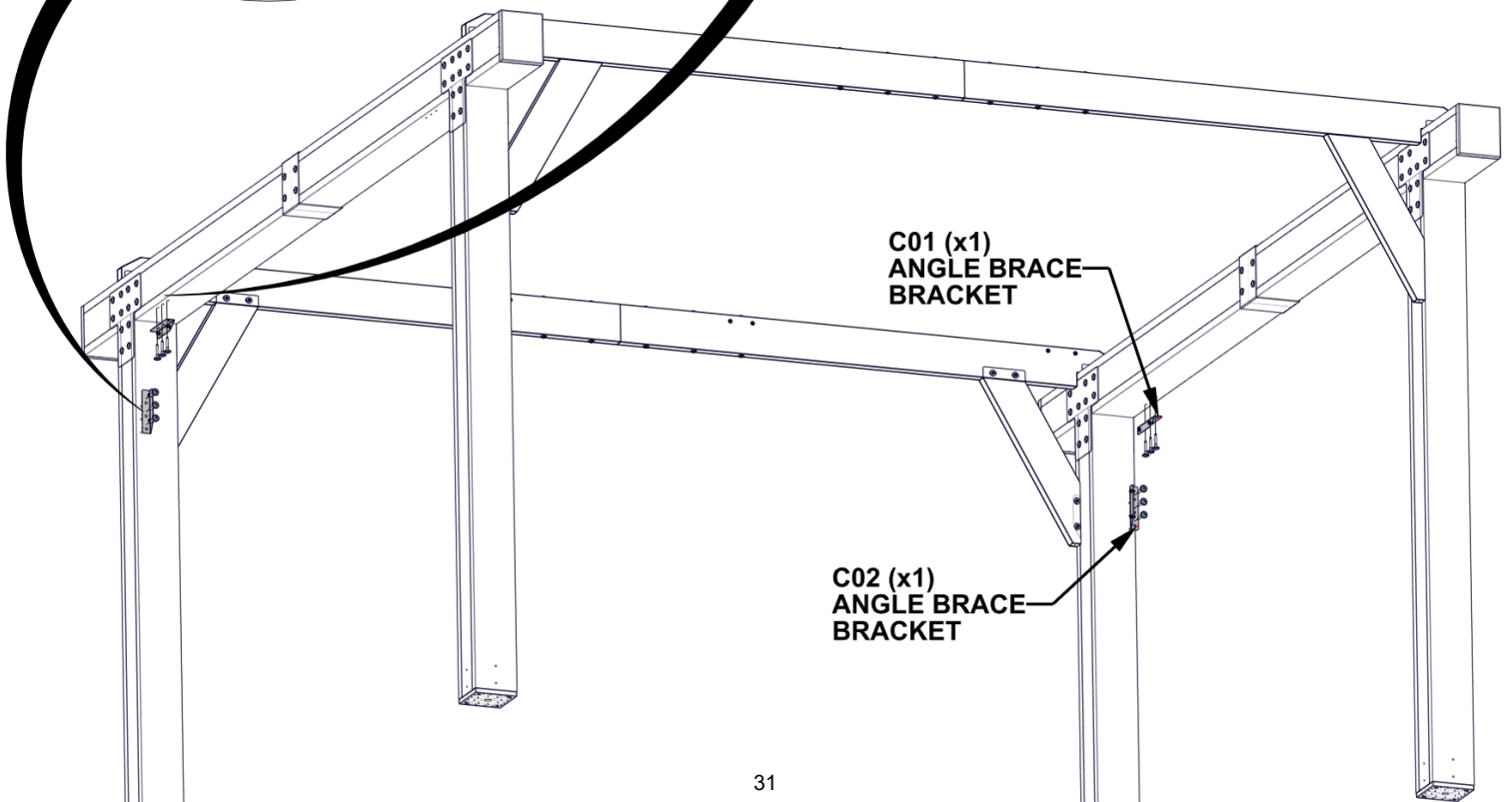

STEP 18 - CORBEL ASSEMBLY

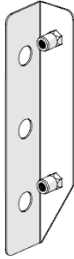

QTY	PART NUMBER	DESCRIPTION
12	H100458	LAG SCREW WH 5/16x2 BLK

C02 ANGLE BRACE BRACKET - A4M04153
(x2) 1 1/16"x1 1/4"x6" (27x31x152)

C01 ANGLE BRACE BRACKET - A4M04148
(x2) 1 1/16"x1 1/4"x6" (27x31x152)

- MEASURE 4-5/8" [117mm] FROM THE INSIDE OF THE POST TO THE BRACKET.

- ALIGN BRACKETS WITH PILOT HOLES AS SHOWN.

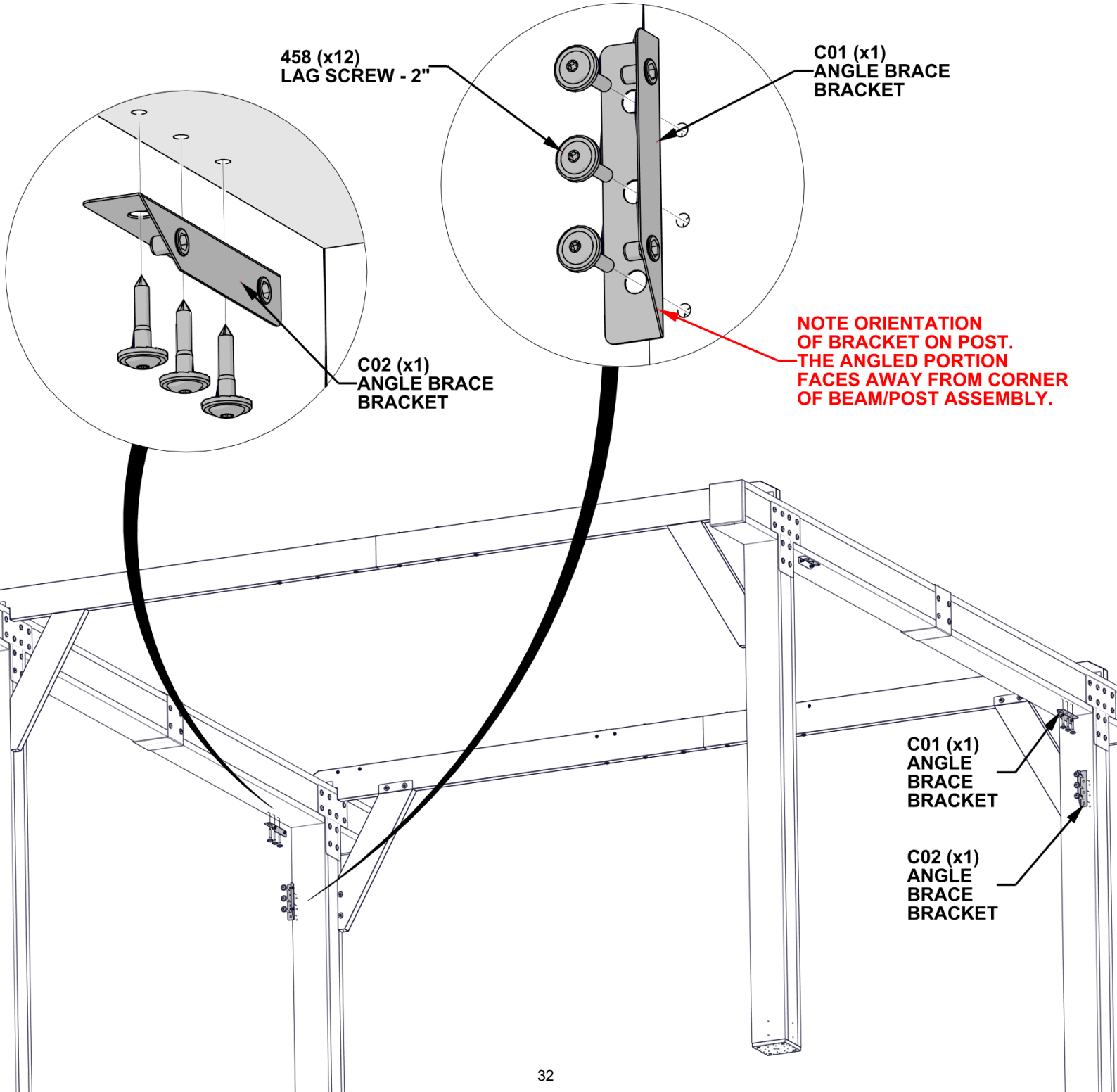

STEP 19 - CORBEL ASSEMBLY

QTY	PART NUMBER	DESCRIPTION
16	H101202	TORX PAN HEAD 1/4-20x3/4" ASSY

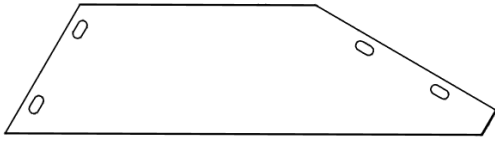

C05 ANGLE BRACE - A4M04320
(x2) 1 7/16"x5 5/16"x20 1/16" (36x135x509)



C06 ANGLE BRACE - A4M04321
(x2) 1 7/16"x5 5/16"x20 1/16" (36x135x509)

- **HAND TIGHTEN UNTIL ALL HARDWARE IS INSERTED. THEN FULLY TIGHTEN.**
- ALIGN ANGLE BRACE WITH THEADED INSERTS AS SHOWN BELOW.

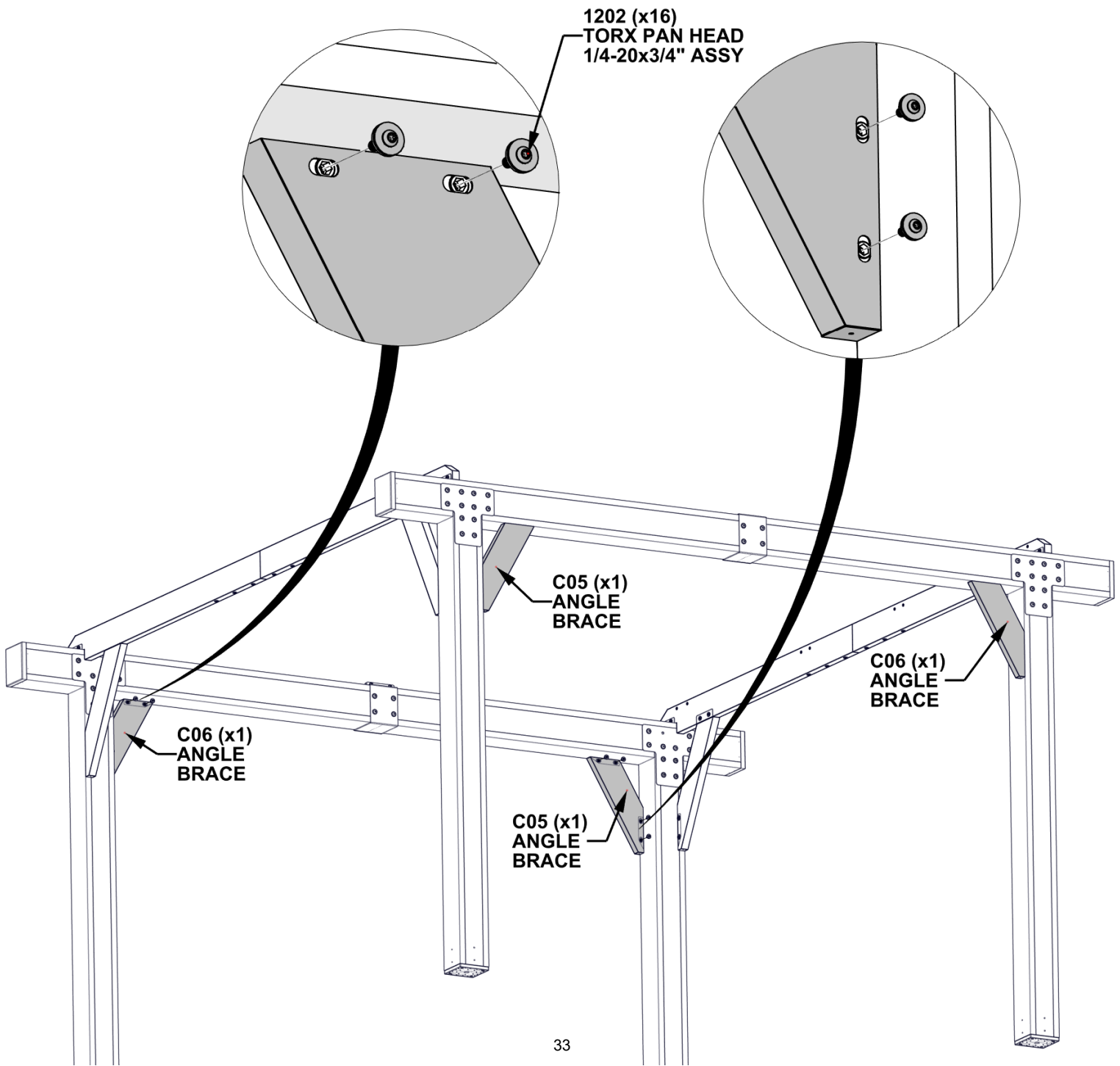

STEP 20 - GABLE ASSEMBLY

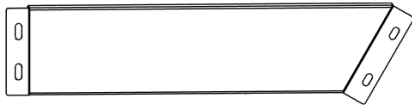

B08 GABLE SUPPORT - A4M04318
(x2) 1 1/2"x5 15/16"x24 5/8" (38x152x625)

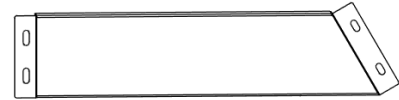

B09 GABLE SUPPORT - A4M04319
(x2) 1 1/2"x5 15/16"x24 5/8" (38x152x625)

QTY	PART NUMBER	DESCRIPTION
12	H101202	TORX PAN HEAD 1/4-20x3/4" ASSY

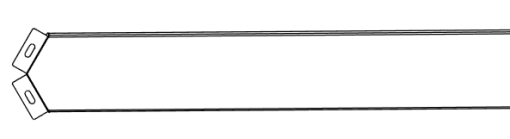

B07 VERTICAL GABLE SUPPORT - A4M04317
(x2) 1 1/2"x9 1/16"x34 11/16" (38x230x882)

- HAND TIGHTEN HARDWARE.

- ALIGN COMPONENTS WITH THREADED INSERTS.

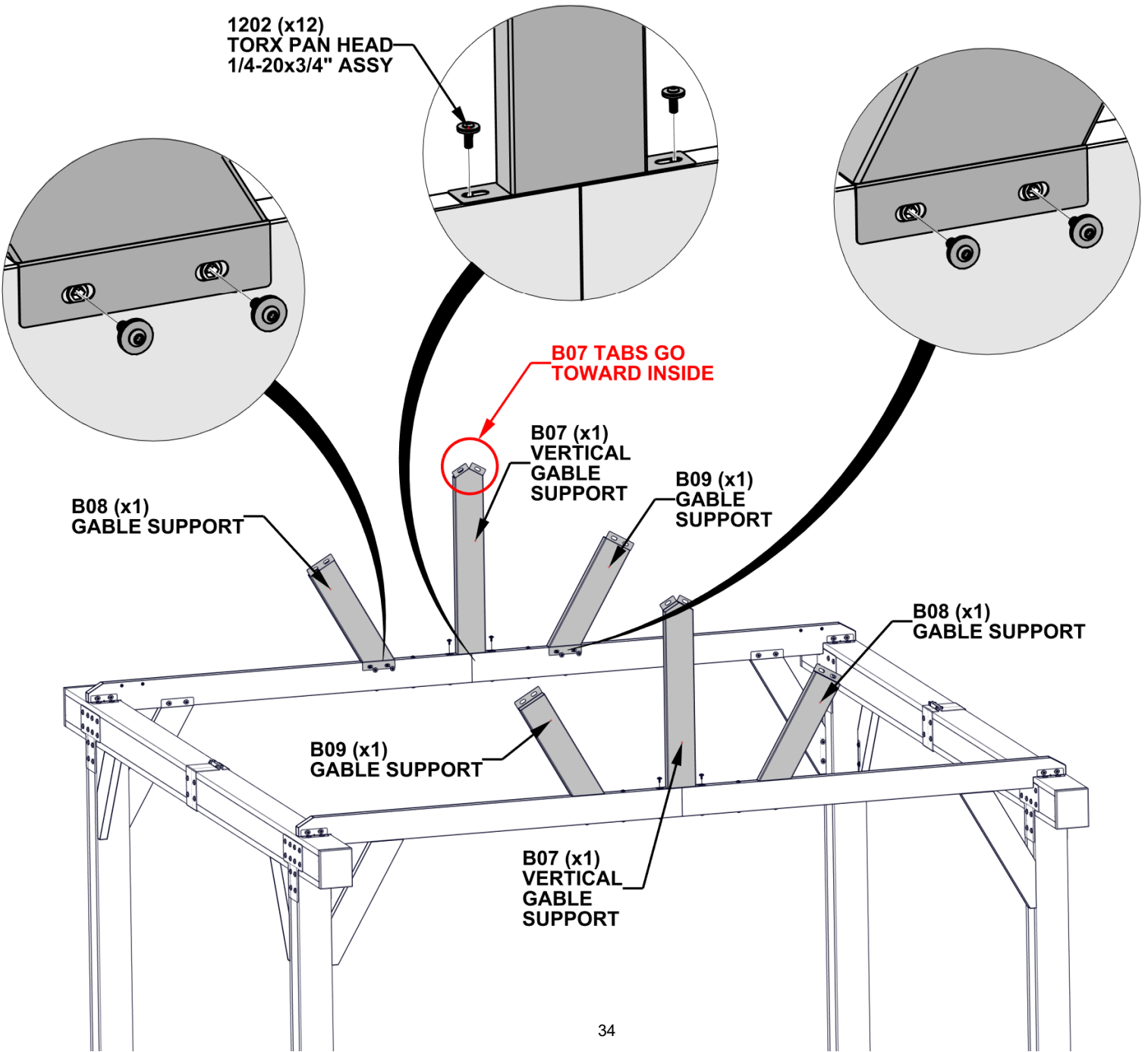

STEP 21 - GABLE ASSEMBLY

QTY	PART NUMBER	DESCRIPTION
10	H101202	TORX PAN HEAD 1/4-20x3/4" ASSY

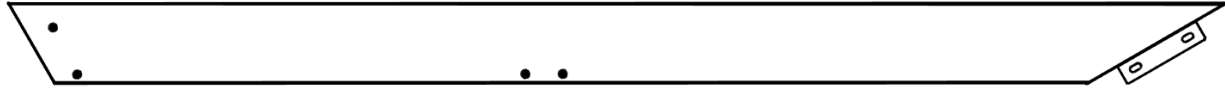

B03 GABLE BEAM - A4M04157
(x2) 1 1/2"x5 1/4"x79 1/2" (38x134x2019)

- HAND TIGHTEN HARDWARE.

- ALIGN COMPONENTS WITH THREADED INSERTS.

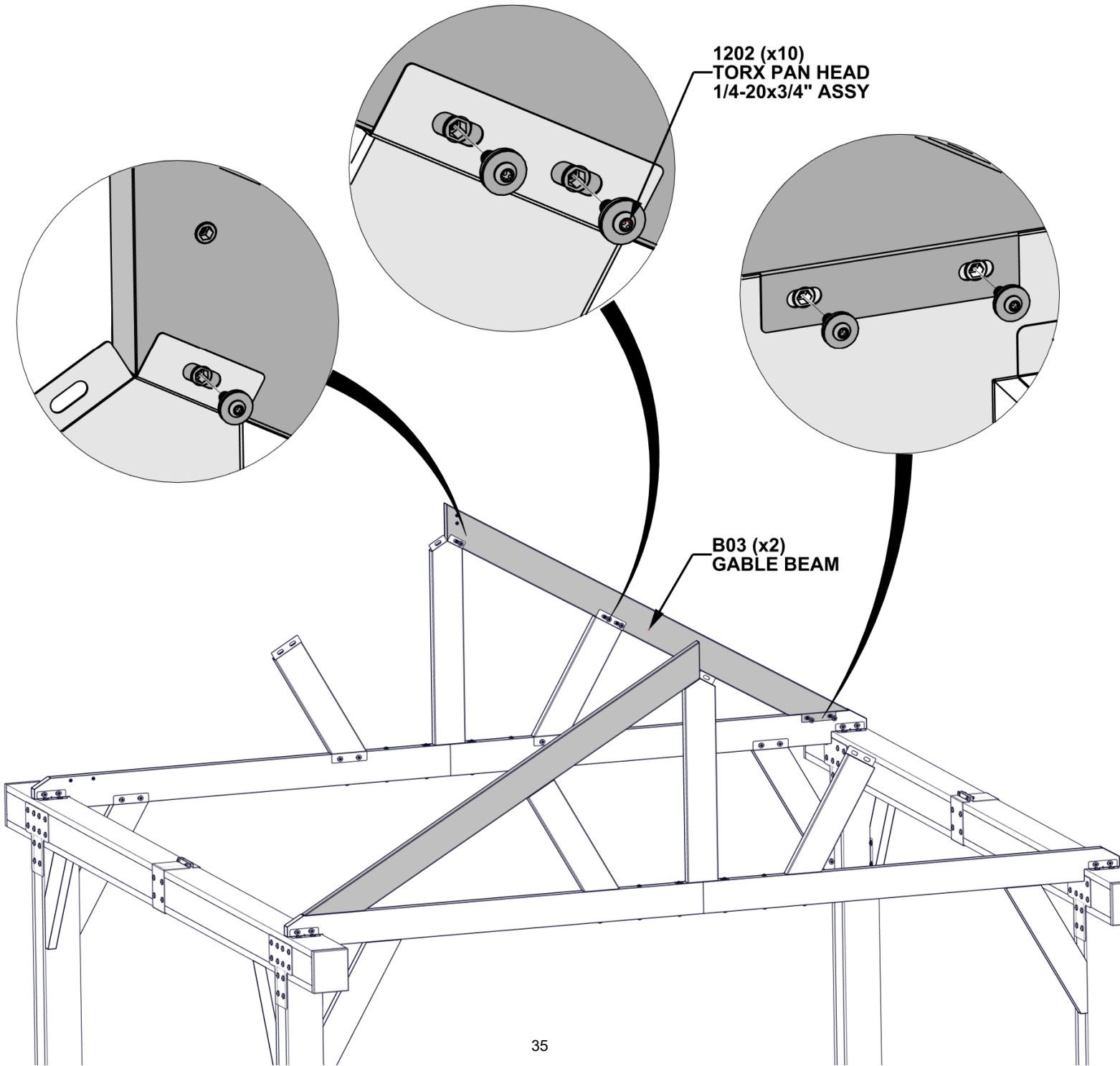

STEP 22 - GABLE ASSEMBLY

QTY	PART NUMBER	DESCRIPTION
10	H101202	TORX PAN HEAD 1/4-20x3/4" ASSY

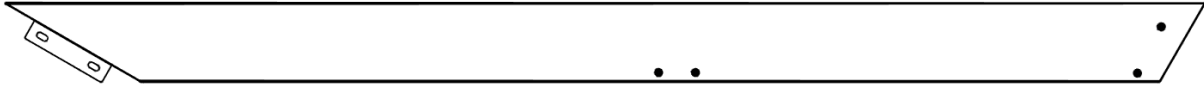

B04 GABLE BEAM - A4M04158
(x2) 1 1/2"x5 1/4"x79 1/2" (38x134x2019)

- HAND TIGHTEN HARDWARE.

- ALIGN COMPONENTS WITH THREADED INSERTS

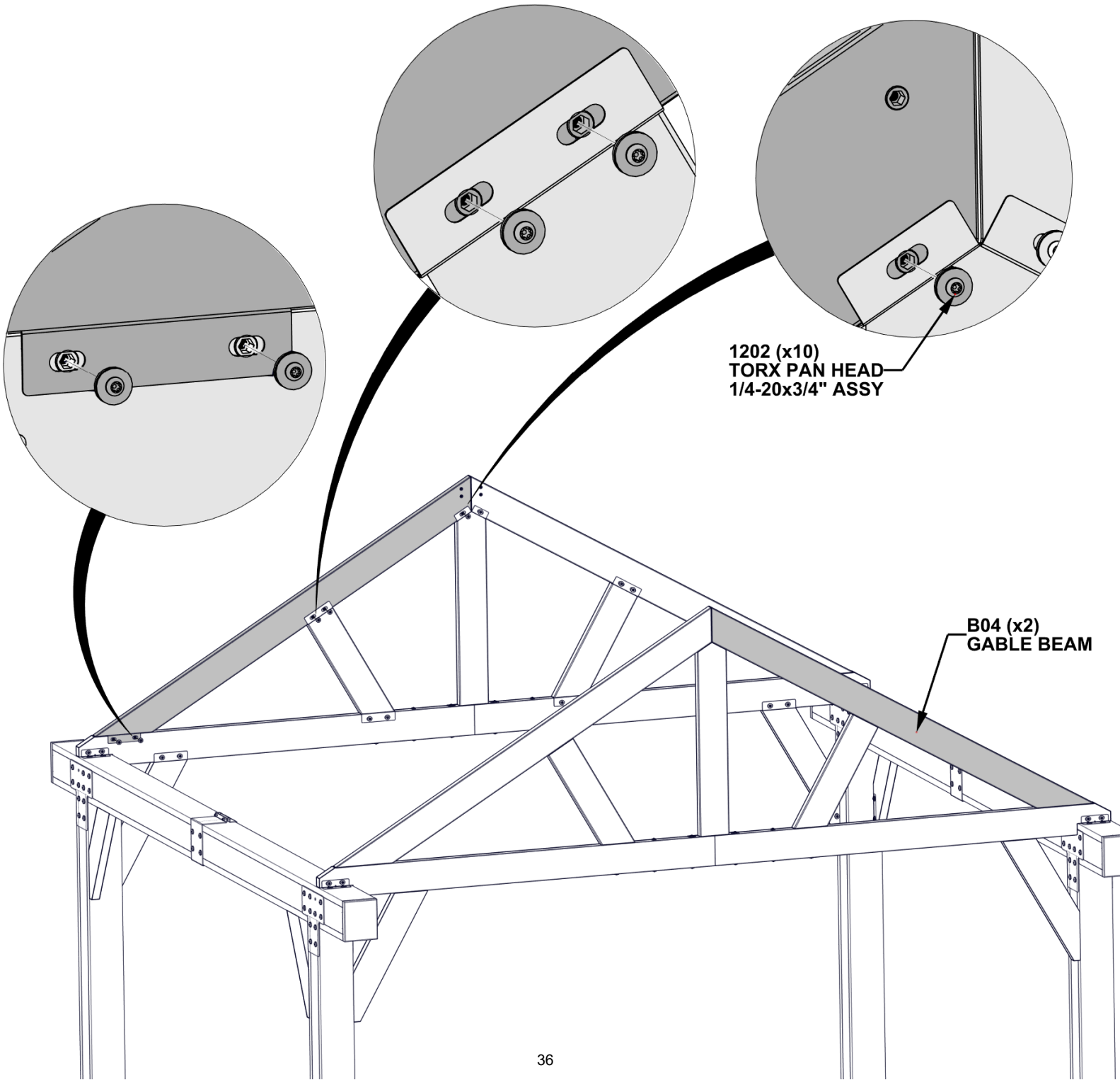

STEP 23 - GABLE ASSEMBLY

QTY	PART NUMBER	DESCRIPTION
8	H101202	TORX PAN HEAD 1/4-20x3/4

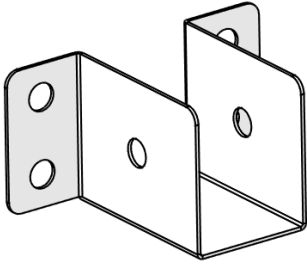

A4M04905 RIDGE CLIP
(x2)

- **HAND TIGHTEN HARDWARE, AFTER ALL HARDWARE HAS BEEN INSTALLED FULLY TIGHTEN ALL HARDWARE FROM PREVIOUS STEPS.**
- ALIGN COMPONENTS WITH THREADED INSERTS

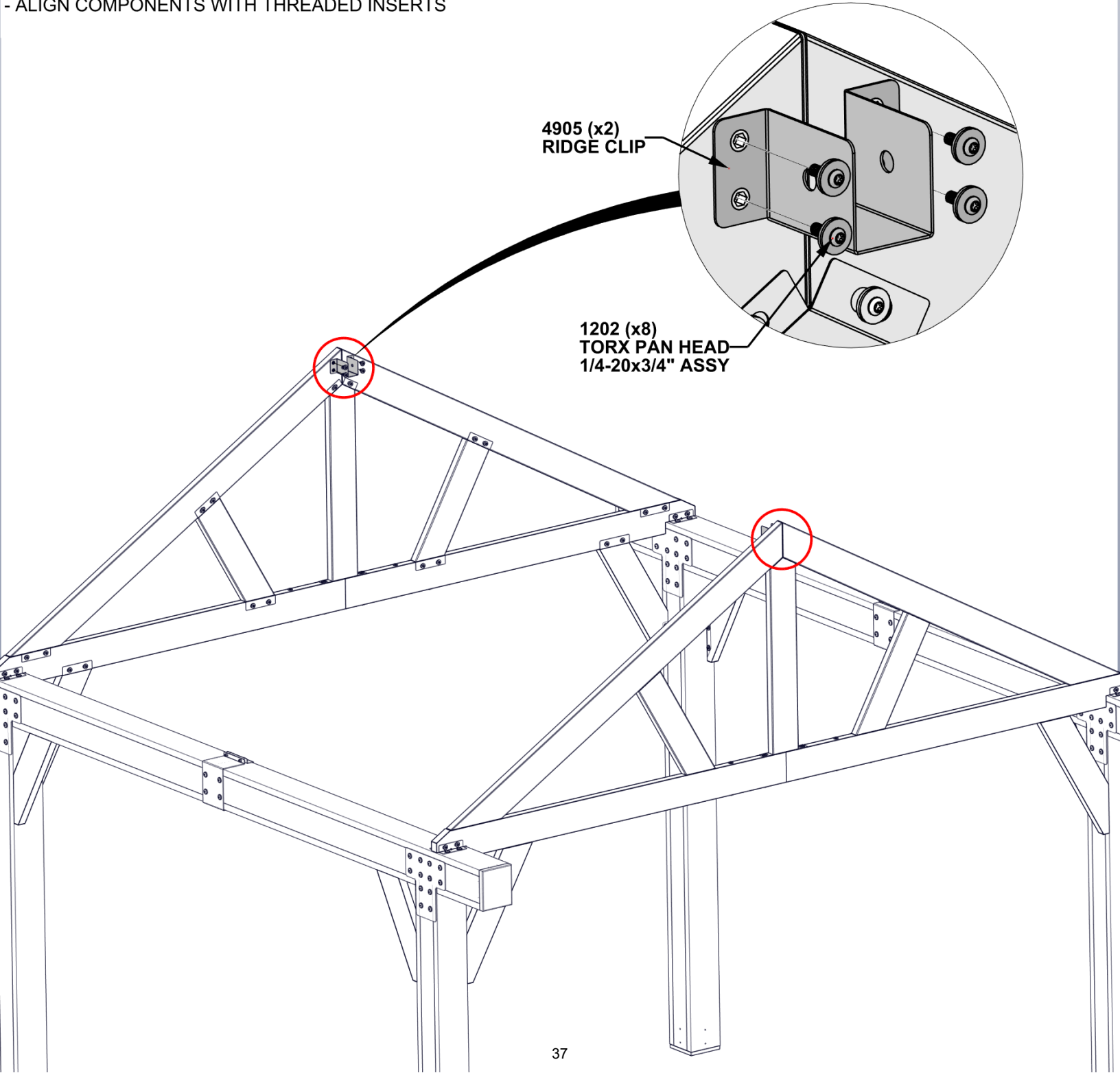

STEP 24A - RIDGE PEAK ASSEMBLY



AD05 PEAK SUPPORT - W4L21172
(x1) 15/16"x4"x52 1/8" (24x102x1324)



AD02 PEAK SUPPORT - W4L21169
(x1) 15/16"x4"x69 3/4" (24x102x1771)



AD04 PEAK SUPPORT - W4L21171
(x1) 15/16"x4"x69 3/4" (24x102x1771)

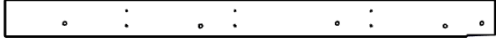

AD03 PEAK SUPPORT - W4L21170
(x1) 15/16"x4"x52 1/8" (24x102x1324)

QTY	PART NUMBER	DESCRIPTION
18	H100382	SCREW PFH 8x1 3/4 BLK

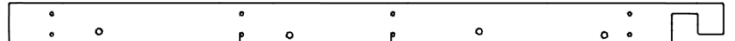

A4M04155 RIDGE PLATE
(x1)

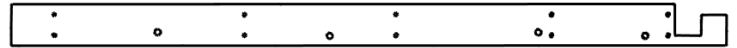

A4M04156 RIDGE PLATE
(x1)

- NOTE ORIENTATION OF AD02, AD03, AD04, AND AD05 BOARDS.
- ALIGN HOLES IN AD02/AD03 BOARDS AND RIDGE PLATE THROUGH HOLES WITH PILOT HOLES IN AD04/AD05 BOARDS.

NOTE ORIENTATION OF NOTCHES

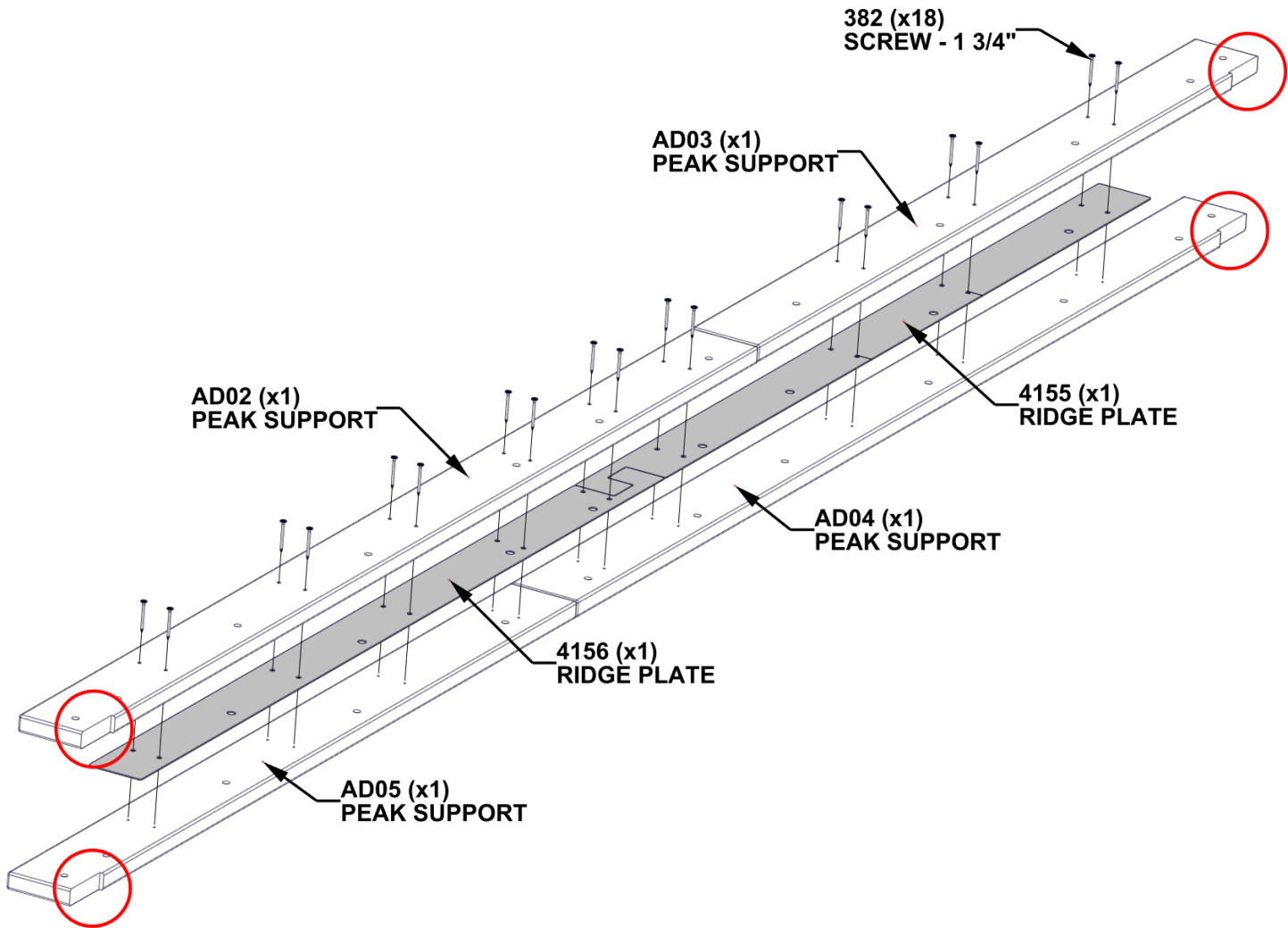

NOTE ORIENTATION OF NOTCHES

STEP 24B - RIDGE PEAK ASSEMBLY

QTY	PART NUMBER	DESCRIPTION
4	H100379	TNUT-5/16" BLK

- ROTATE ASSEMBLY FROM PREVIOUS STEP TO REFLECT SCREWS FACING DOWN.

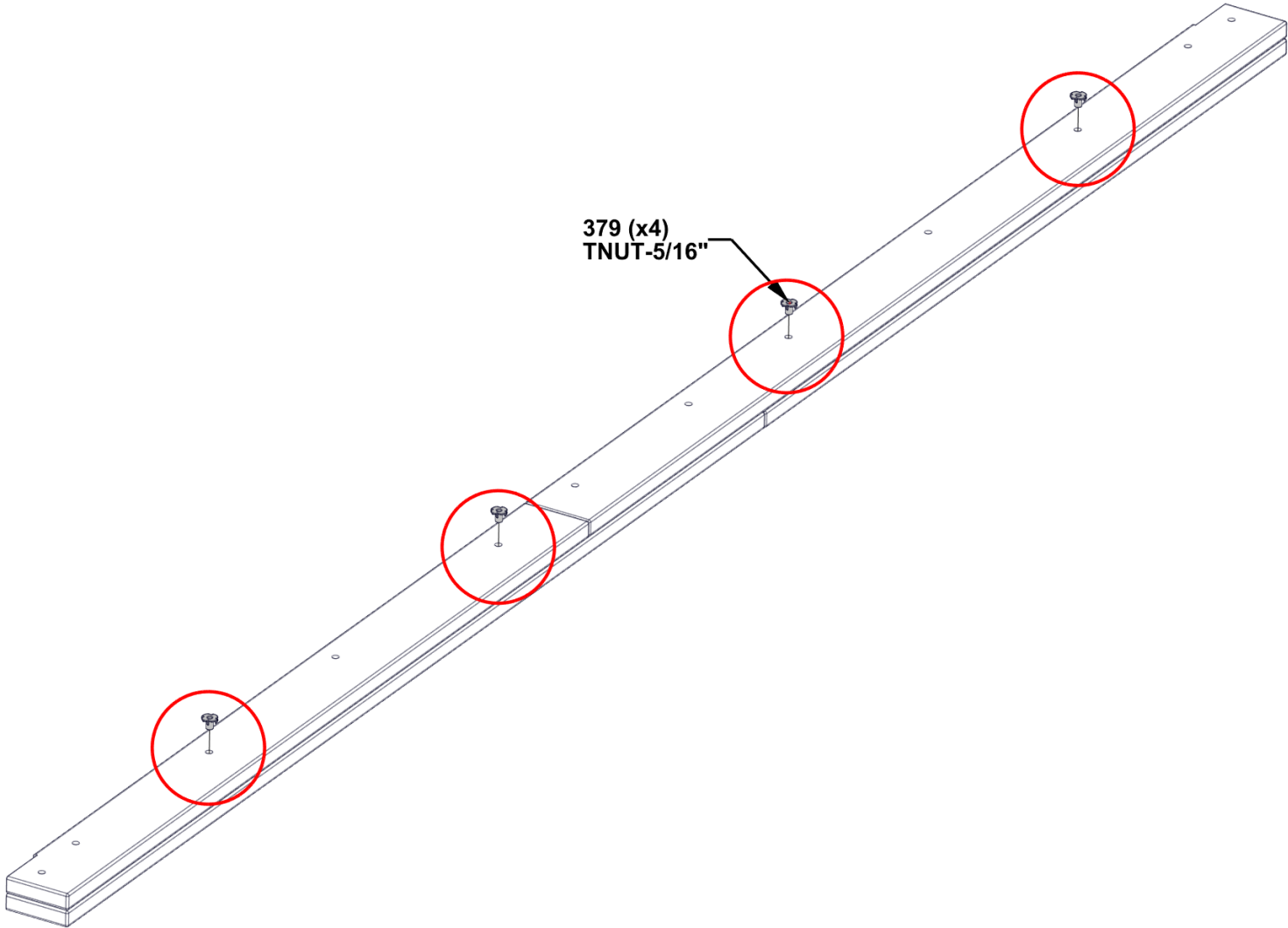

STEP 25 - RIDGE PEAK ASSEMBLY

QTY	PART NUMBER	DESCRIPTION
2	H100195	BOLT WH 5/16x2 3/4 BLK
2	H100479	NUT LOCK 5/16 BLK
2	H100630	WASHER FLAT 8x19 BLK

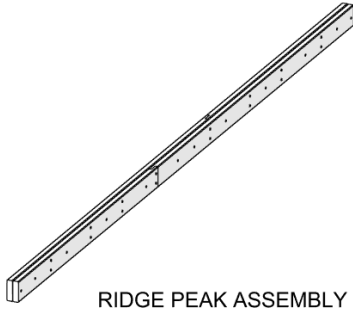

- ALIGN HOLES IN RIDGE PEAK ASSEMBLY FROM PREVIOUS STEP WITH HOLES IN RIDGE CLIP BRACKET.
- FULLY TIGHTEN HARDWARE.

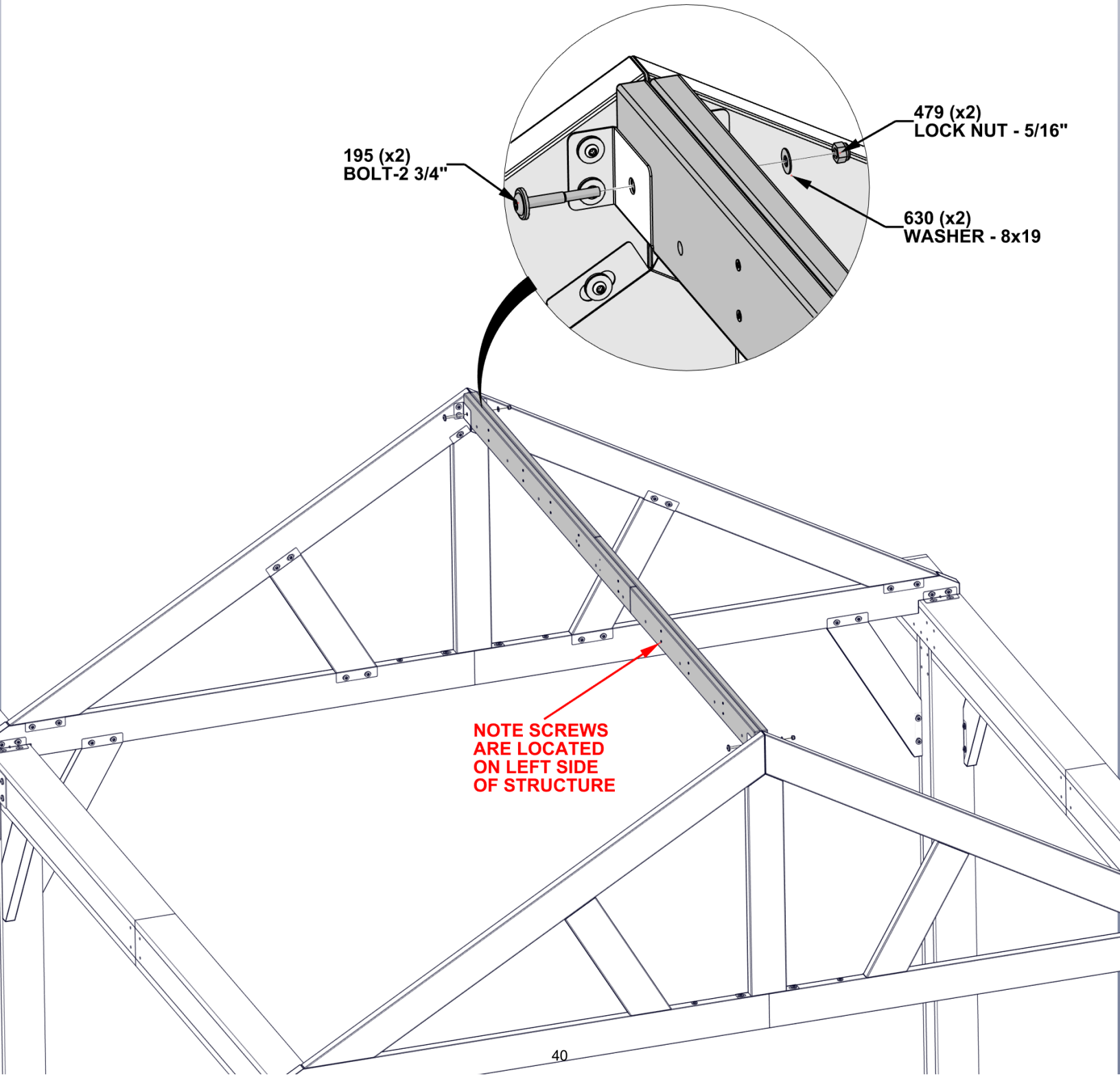

STEP 26A - ROOF PANEL 'A' ASSEMBLY

QTY	PART NUMBER	DESCRIPTION
16	H100201	SCREW PFH 8x2 1/2 BLK
4	H100379	T-NUT 5/16 BLK
16	H100391	SCREW PFH 8x2 BLK

E11 RAFTER - W4L21895
(x2) 1 7/16"x3 3/8"x95 1/16" (36x86x2414)

E02 RAFTER - W4L21178
(x2) 1 7/16"x3 3/8"x95 1/16" (36x86x2414)

E08 RAFTER - W4L21799
(x2) 1 7/16"x3 3/8"x95 1/16" (36x86x2414)

E07 RAFTER - W4L21561
(x2) 1 7/16"x3 3/8"x95 1/16" (36x86x2414)

E09 ROOF TRIM W/ PRODUCT ID TAG - W2A04546
(x1) 1 1/2"x3 3/8"x73 11/16" (39x86x1872)

E03 TRIM BOARD - W4L21165
(x1) 1 7/16"x3 3/8"x72 5/16" (36x86x1836)

AD01 RIDGE SUPPORT - W4L21168
(x1) 15/16"x4"x58 1/2" (24x102x1486)

AD07 RIDGE SUPPORT - W4L21559
(x1) 15/16"x4"x57 1/16" (24x102x1450)

- INSERT T-NUTS FIRST. FAILURE TO DO SO WILL RESULT IN INCORRECT ASSEMBLY.
- NOTE THAT CIRCLED ENDS OF AD01 AND AD07 BOARDS ARE LOCATED AWAY FROM MIDDLE RAFTERS AND HOLES ARE ORIENTATED TOWARD BOTTOM OF BOARD.
- ALIGN AD01, AD07 E09, AND E03 WITH PILOT HOLES IN RAFTER BOARDS.

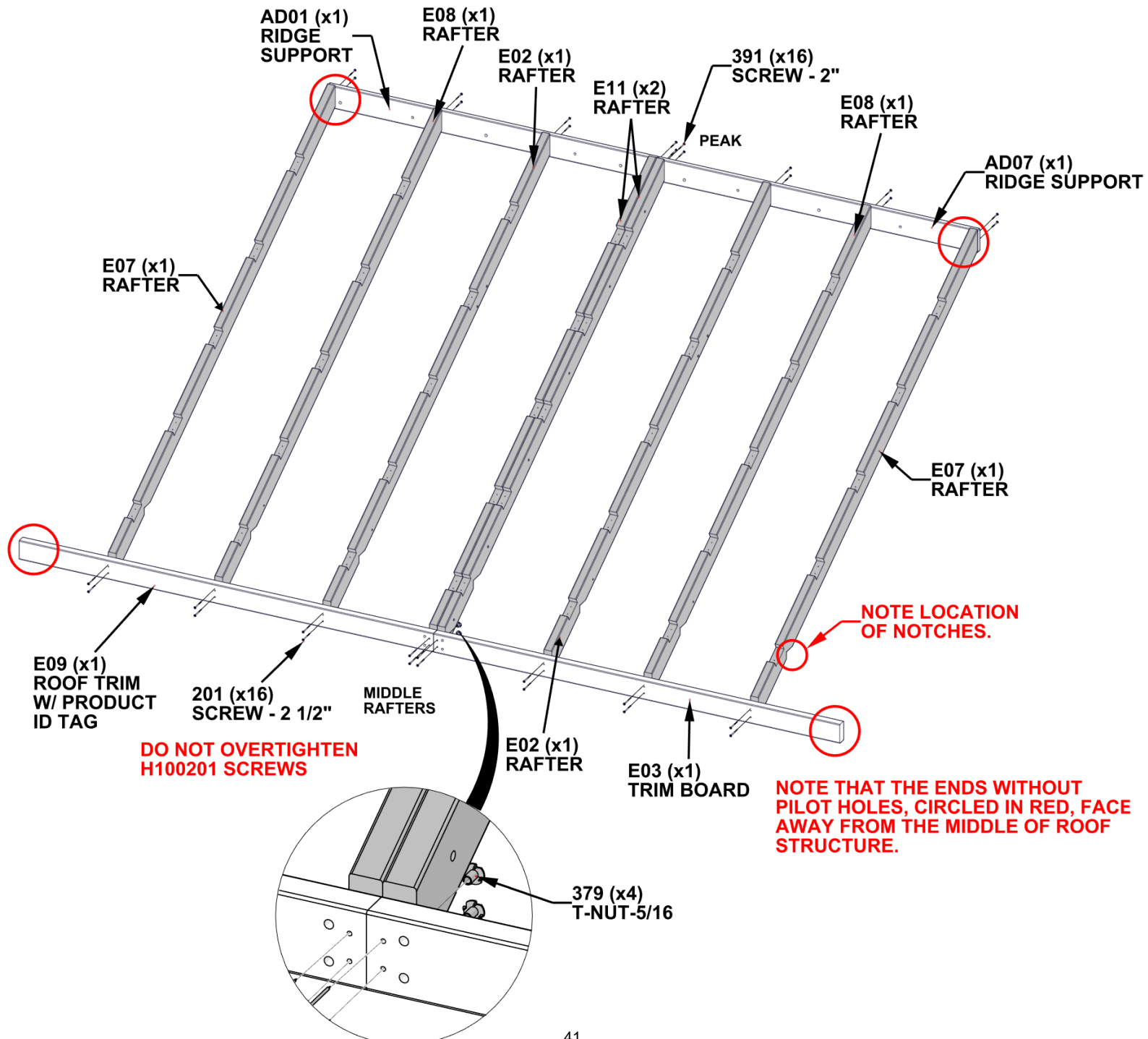

STEP 26B - ROOF PANEL 'A' ASSEMBLY

QTY	PART NUMBER	DESCRIPTION
6	H100198	WASHER LOCK EXT 8x19
6	H100478	WASHER FLAT 9.5x27 BLK
6	H100479	NUT LOCK 5/16 BLK
6	H100503	BOLT WH 5/16x3 1/2 BLK

- ALIGN HOLES IN MIDDLE RAFTERS AND FASTEN HARDWARE AS SHOWN.

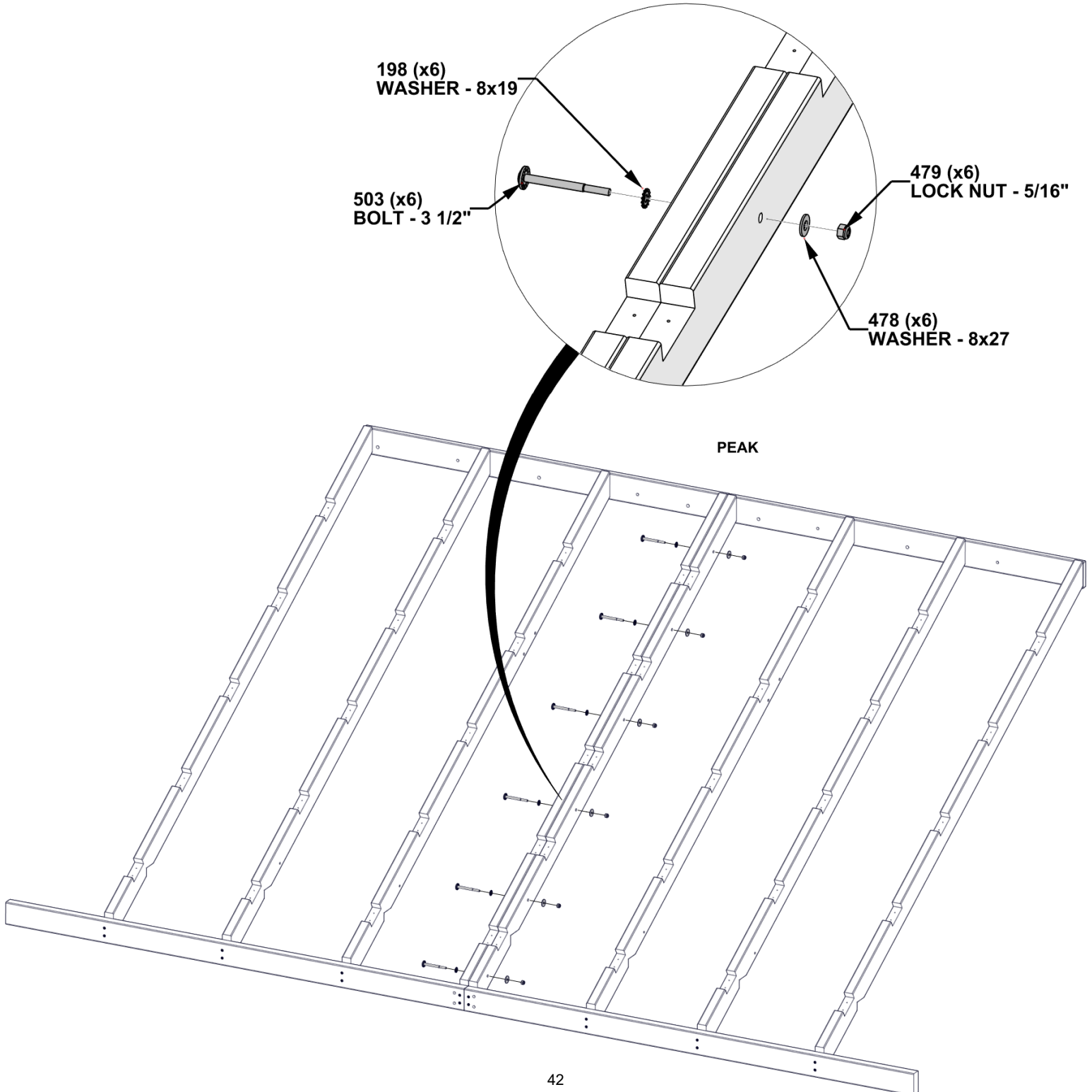

STEP 26C - ROOF PANEL 'A' ASSEMBLY

QTY	PART NUMBER	DESCRIPTION
20	H100171	BOLT WH 1/4x1 BLK
20	H100398	TNUT-1/4" BLK

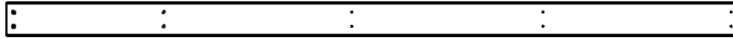

H01 PURLIN - W4L21166
(x5) 15/16"x3 3/8"x73 5/8" (24x86x1870)

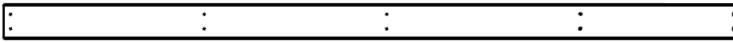

H02 PURLIN - W4L21557
(x5) 15/16"x3 3/8"x72 3/16" (24x86x1834)

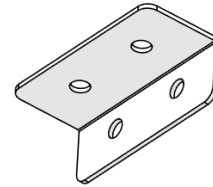

A4M04154 PURLIN SUPPORT BRACKET
(x10)

- INSERT T-NUTS FIRST.

- NOTE ORIENTATION OF 4154 BRACKET, LONG SECTION FASTENS TO PURLIN BOARD.
- COMPLETE THIS STEP 5 TIMES.

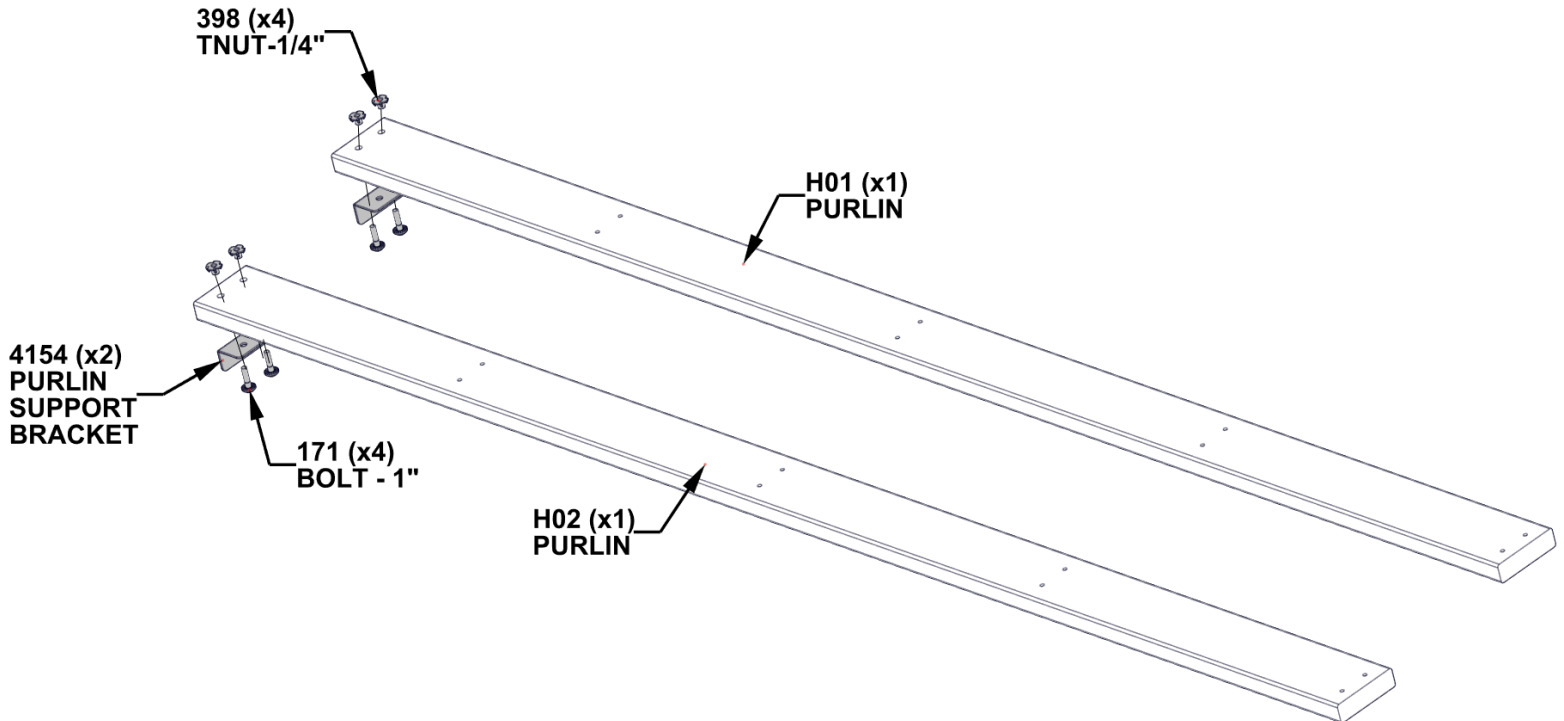

STEP 26D - ROOF PANEL 'A' ASSEMBLY

QTY	PART NUMBER	DESCRIPTION
80	H100391	SCREW PFH 8x2 BLK

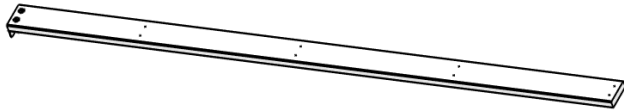

H01 PURLIN ASSEMBLY - STEP 26C

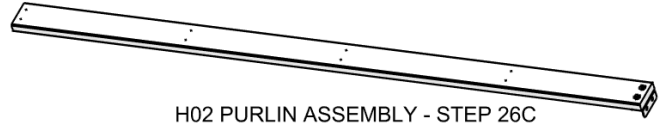

H02 PURLIN ASSEMBLY - STEP 26C

- INSERT T-NUTS FIRST.

- ALIGN PURLINS WITH PILOT HOLES IN RAFTERS

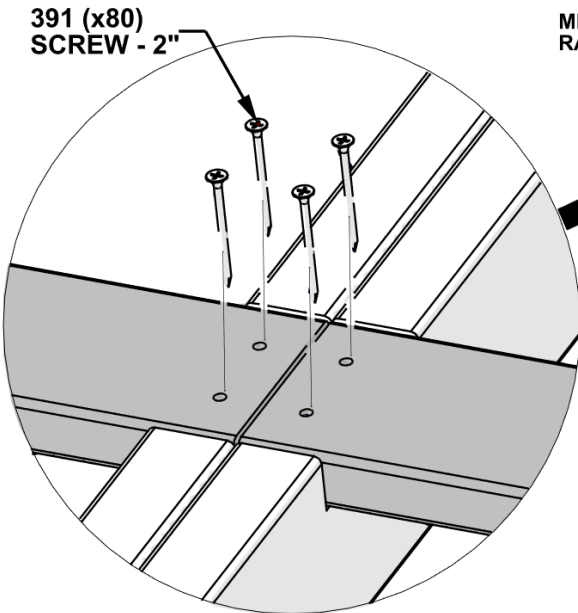
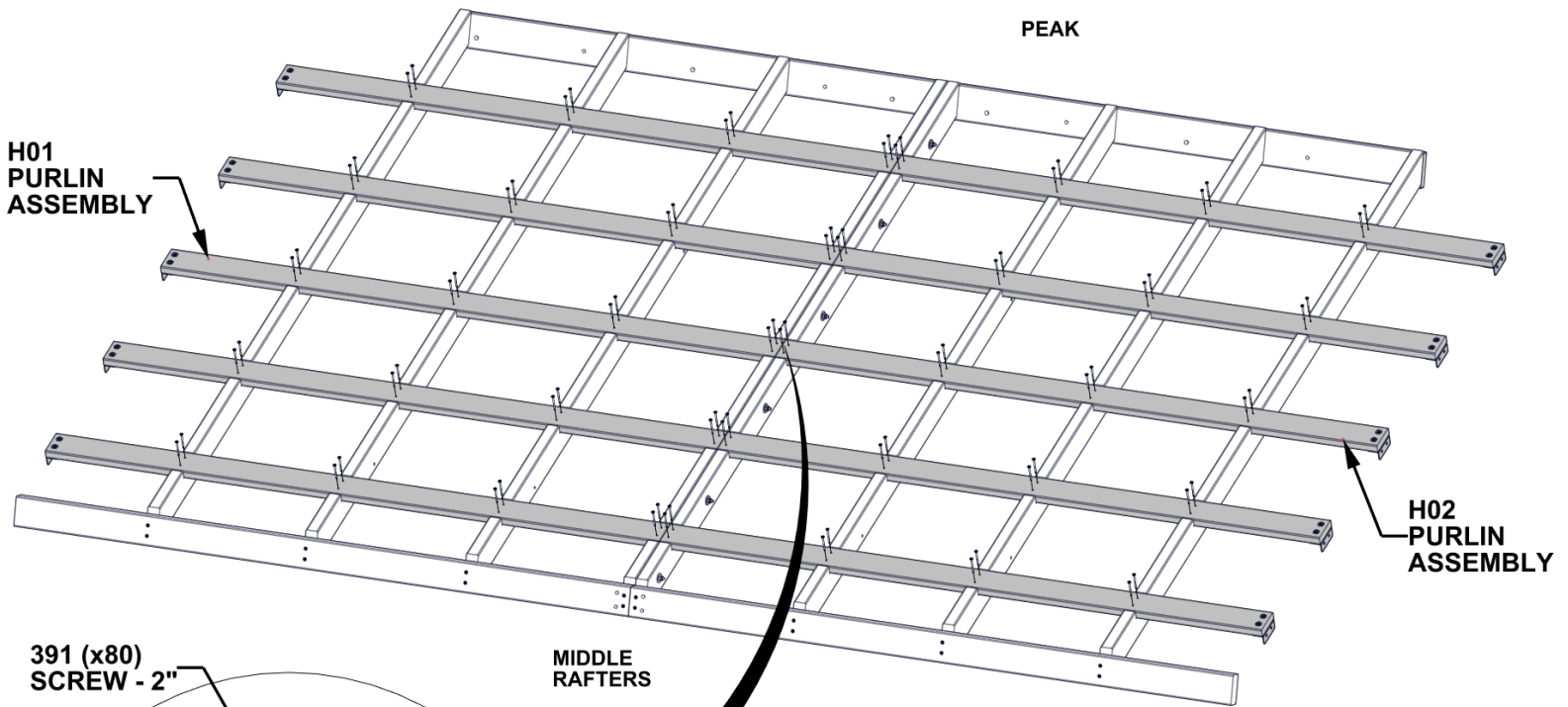

15-1/8" [384mm]

OVERHANG DISTANCE FOR PURLINS IS 15-1/8" [384mm] FROM END OF PURLIN TO RAFTER BOARD ON BOTH ENDS

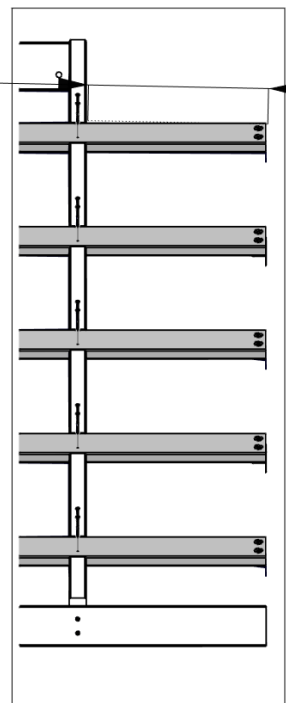

STEP 26E - ROOF PANEL 'A' ASSEMBLY

QTY	PART NUMBER	DESCRIPTION
6	H100379	T-NUT 5/16 BLK
20	H100460	LAG SCREW WH 1/4x1 BLK

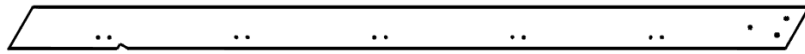

D01 FASCIA - W4L21164
(x1) 1 7/16"x5 1/4"x100" (36x134x2540)

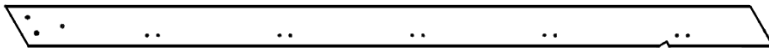

D02 FASCIA - W4L21175
(x1) 1 7/16"x5 1/4"x100" (36x134x2540)

- INSERT T-NUTS FIRST.

- ALIGN D01 AND D02 PILOT HOLES WITH HOLES IN 4154 BRACKETS.

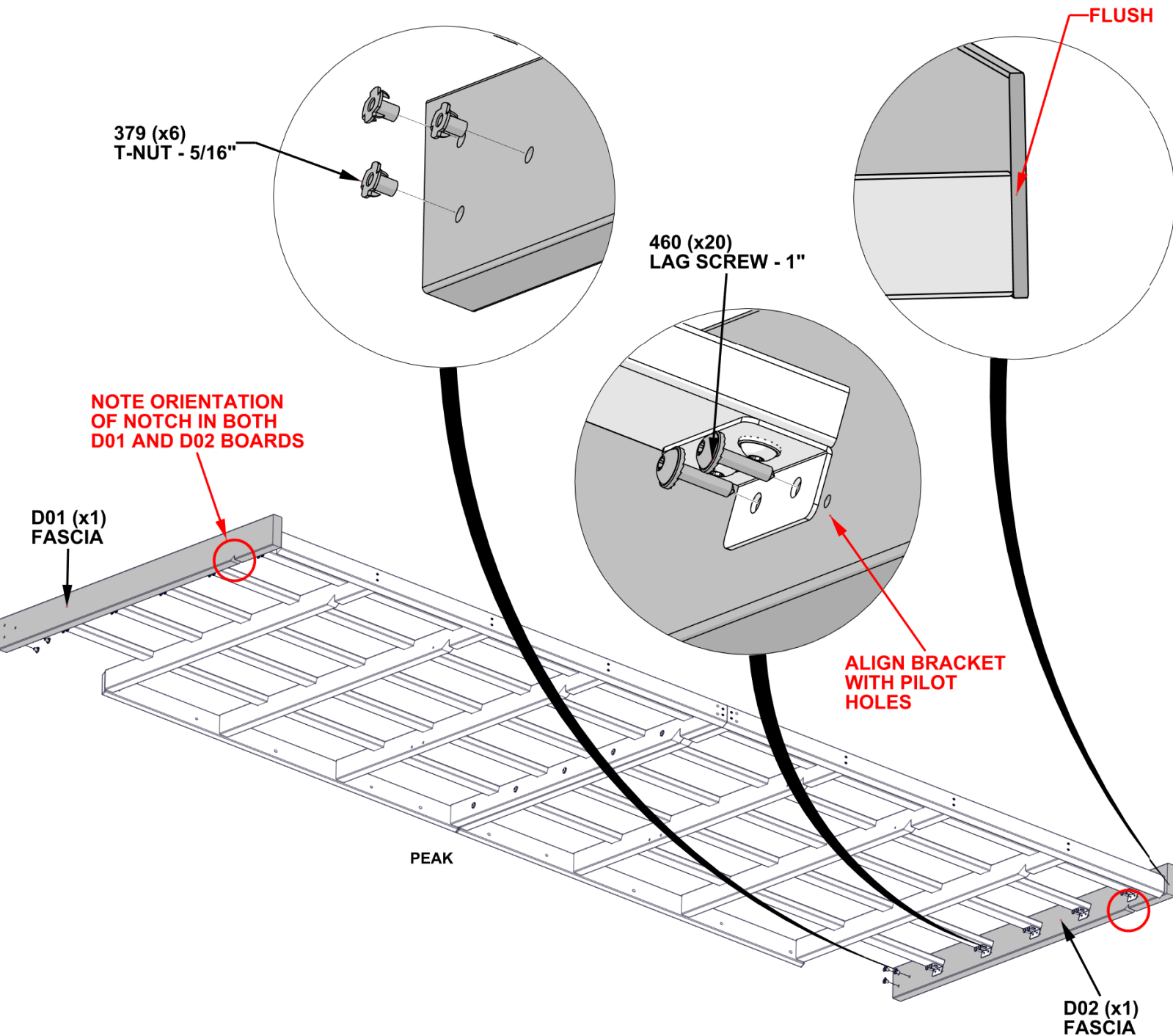

STEP 26F - ROOF PANEL 'A' ASSEMBLY

QTY	PART NUMBER	DESCRIPTION
8	H100797	SCREW PWH 8x1 BLK

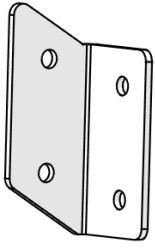

A4M04907 FASCIA BRACKET
(x1)

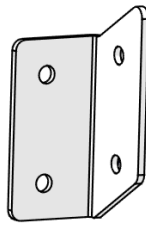

A4M04908 FASCIA BRACKET
(x1)

- ALIGN BRACKET 1/4" [6mm] FROM TOP OF TRIM BOARD AS SHOWN.
- ATTACH FASCIA BRACKET 4907 AND 4908 BY DRILLING A 1/8" [3mm] PILOT HOLE AND FASTENING WITH 797 SCREWS.

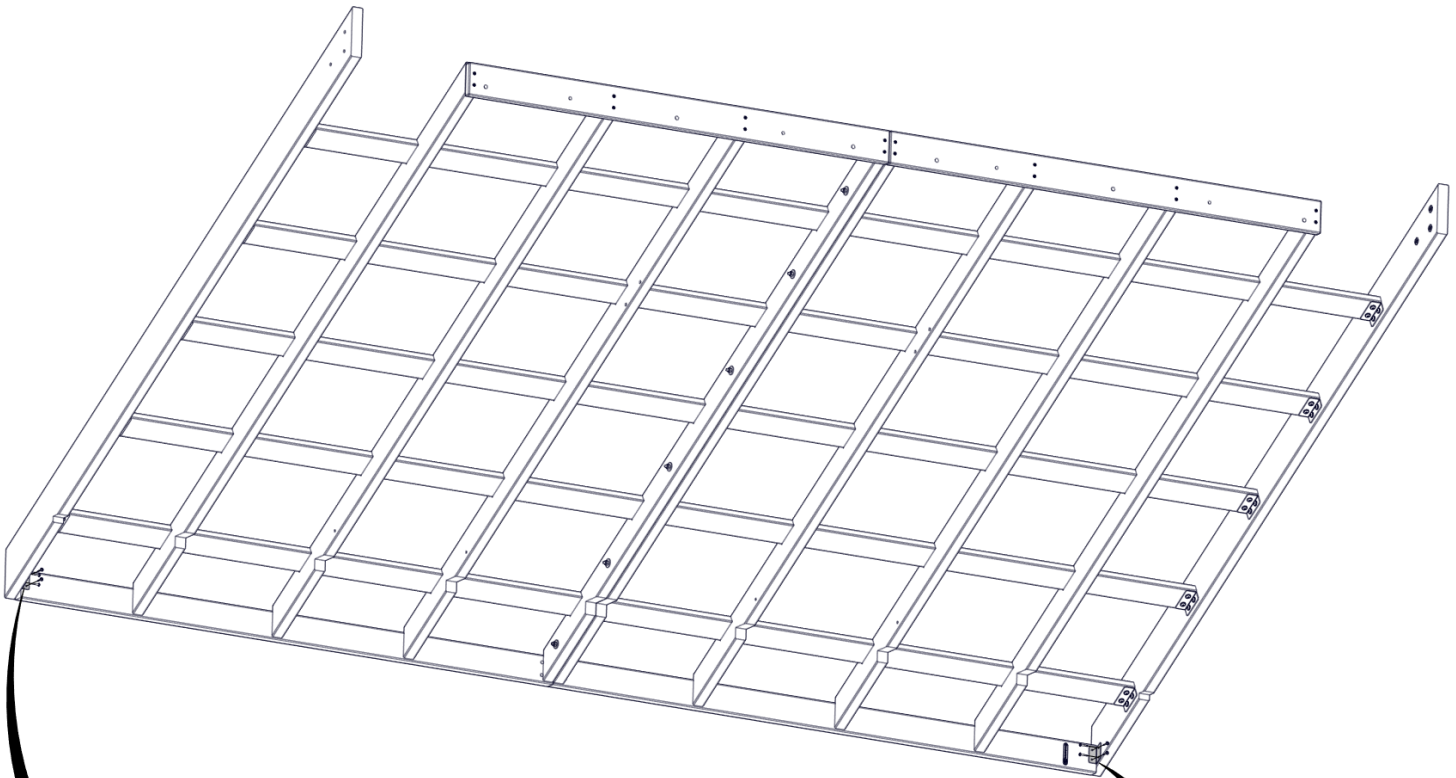

ALIGN BRACKET
1/4" [6mm] FROM
TOP OF TRIM BOARD

ALIGN BRACKET
1/4" [6mm] FROM
TOP OF TRIM BOARD

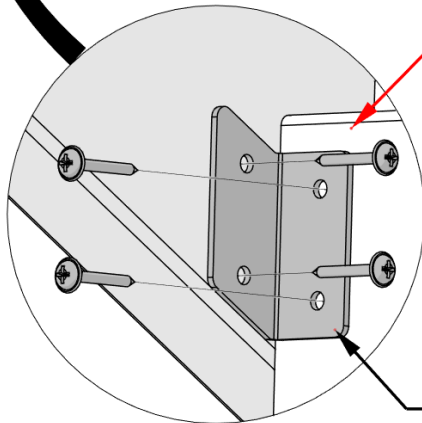

4907 (x1)
FASCIA BRACKET

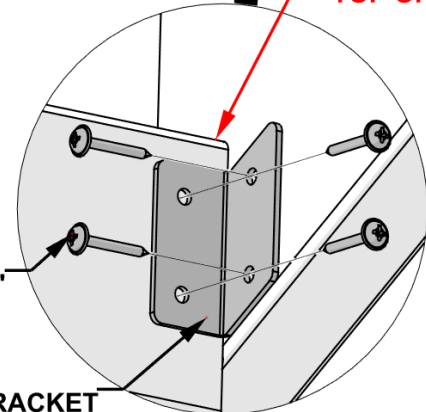

797 (x8)
SCREW - 1"

4908 (x1)
FASCIA BRACKET

STEP 26G - ROOF PANEL 'A' ASSEMBLY

- CRITICAL:**
- SQUARE UNIT BEFORE PROCEEDING TO NEXT STEPS.
 - THE BELOW DIMENSIONS ARE CRITICAL TO THE FINAL ROOF ASSEMBLY.
 - MEASUREMENTS BELOW SHOULD BE HELD WITH IN +/- 1/4" [6mm].
 - MEASUREMENTS OUTSIDE OF TOLERANCE WILL LEAD TO THE INABILITY TO ASSEMBLE THE ROOF.

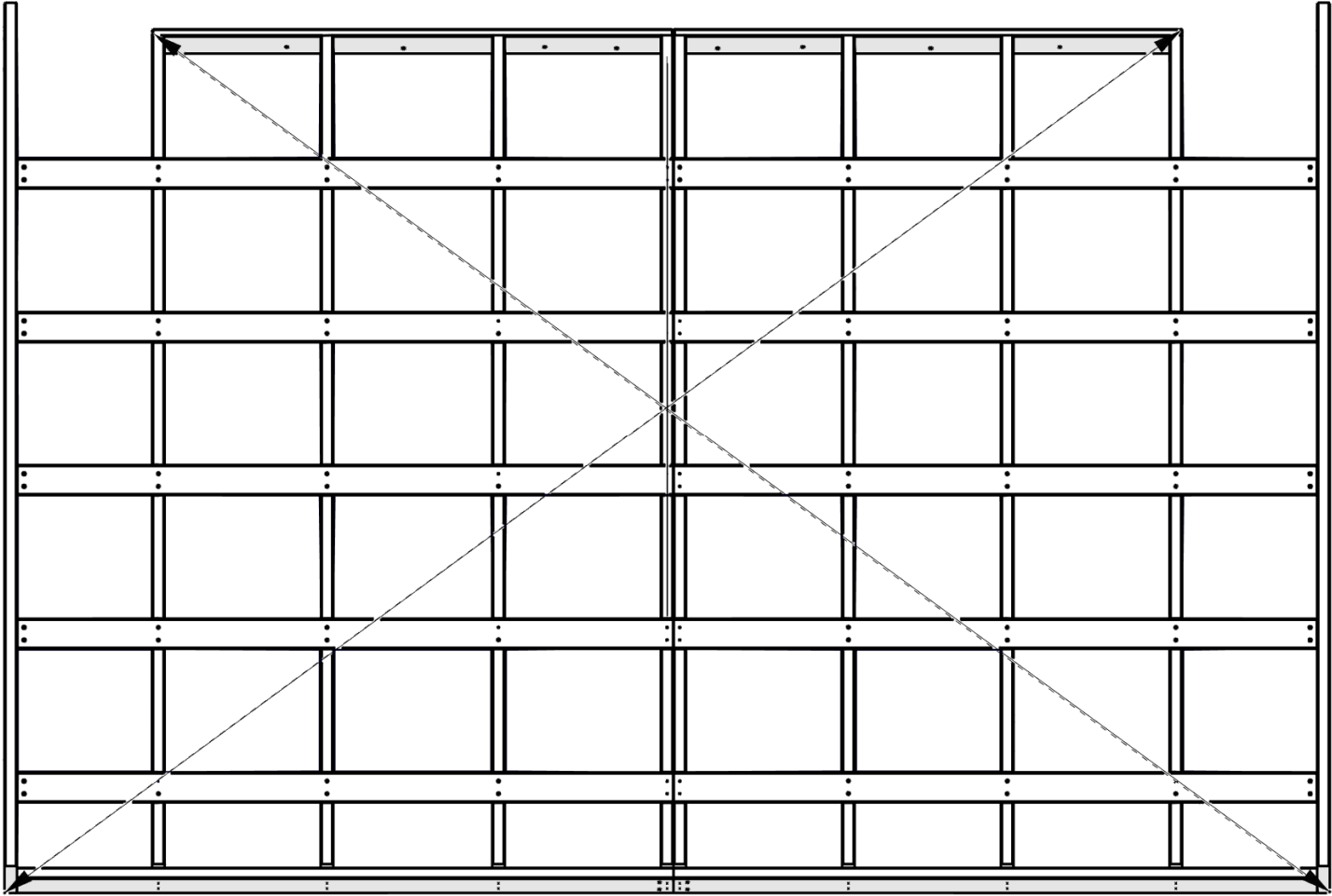

13-7 13/16" [4161mm]

13-7 13/16" [4161mm]

TIP : LOOSEN HARDWARE TO ADJUST FOR SQUARING IF NEEDED

STEP 27 - ROOF PANEL 'A' ASSEMBLY

- USE THIS PAGE TO FAMILIARIZE YOUR SELF WITH ROOF PANEL AND ASSIST YOU IN STEPS 28-31.
- REMOVE PROTECTIVE BLUE FILM.
- START AT THE END INDICATED AND ASSEMBLE IN THE DIRECTION OF THE ARROW

- **GLOVES SHOULD BE WORN WHEN HANDLING ROOF PANELS: EDGES ARE SHARP.**
- **START BY PLACING FIRST SHEET 1/8" [3mm] FROM D02 FASCIA BOARD, THE LAST SHEET SHOULD ALIGN CLOSE TO THE EDGE OF THE D01 FASCIA BOARD.**

ROOF SHEET WITH FULL RIB WILL OVERLAP MIDDLE RAFTERS

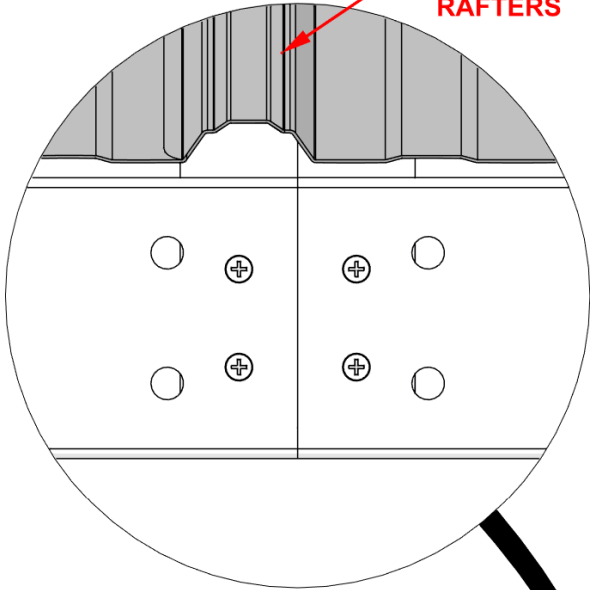

THE PRE- DRILLED HOLES ON EACH PANEL SHOULD ALWAYS BE POSITIONED ON THE RIDGE SIDE.

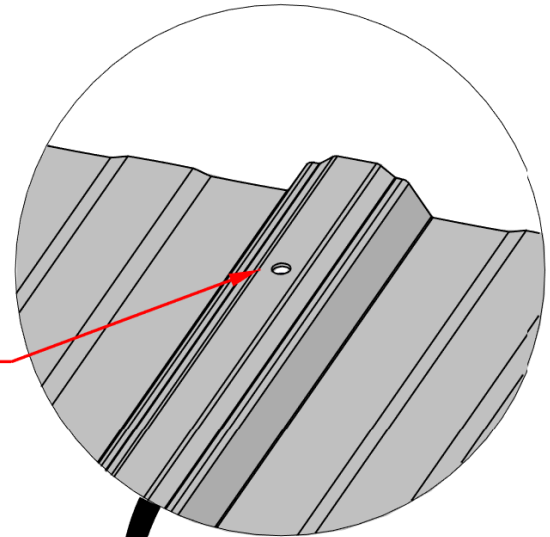

D01 FASCIA

PEAK

D02 FASCIA



STEP 28 - ROOF PANEL 'A' ASSEMBLY

QTY	PART NUMBER	DESCRIPTION
35	H101117	SCREW WOODGRIP 10-16x3/4" BLK



A4M04160 29GA STEEL SHEETING
(x1)



A4M04159 29GA STEEL SHEETING
(x1)

- MAKE SURE ROOF PANEL IS SQUARE BEFORE MOVING ON.

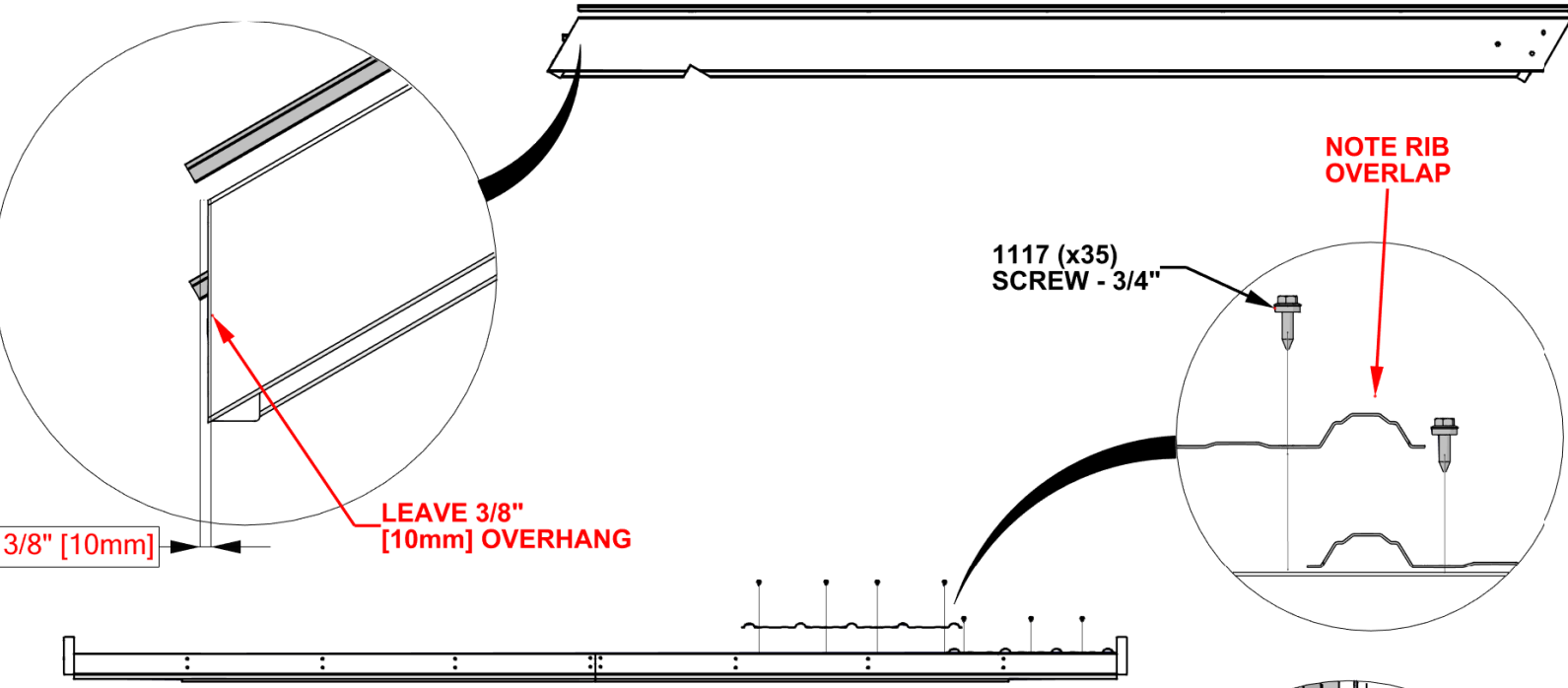

SHEETING SHOULD MEASURE 1/8" [3mm] FROM THE EDGE TO THE D02 BOARD AS SHOWN.

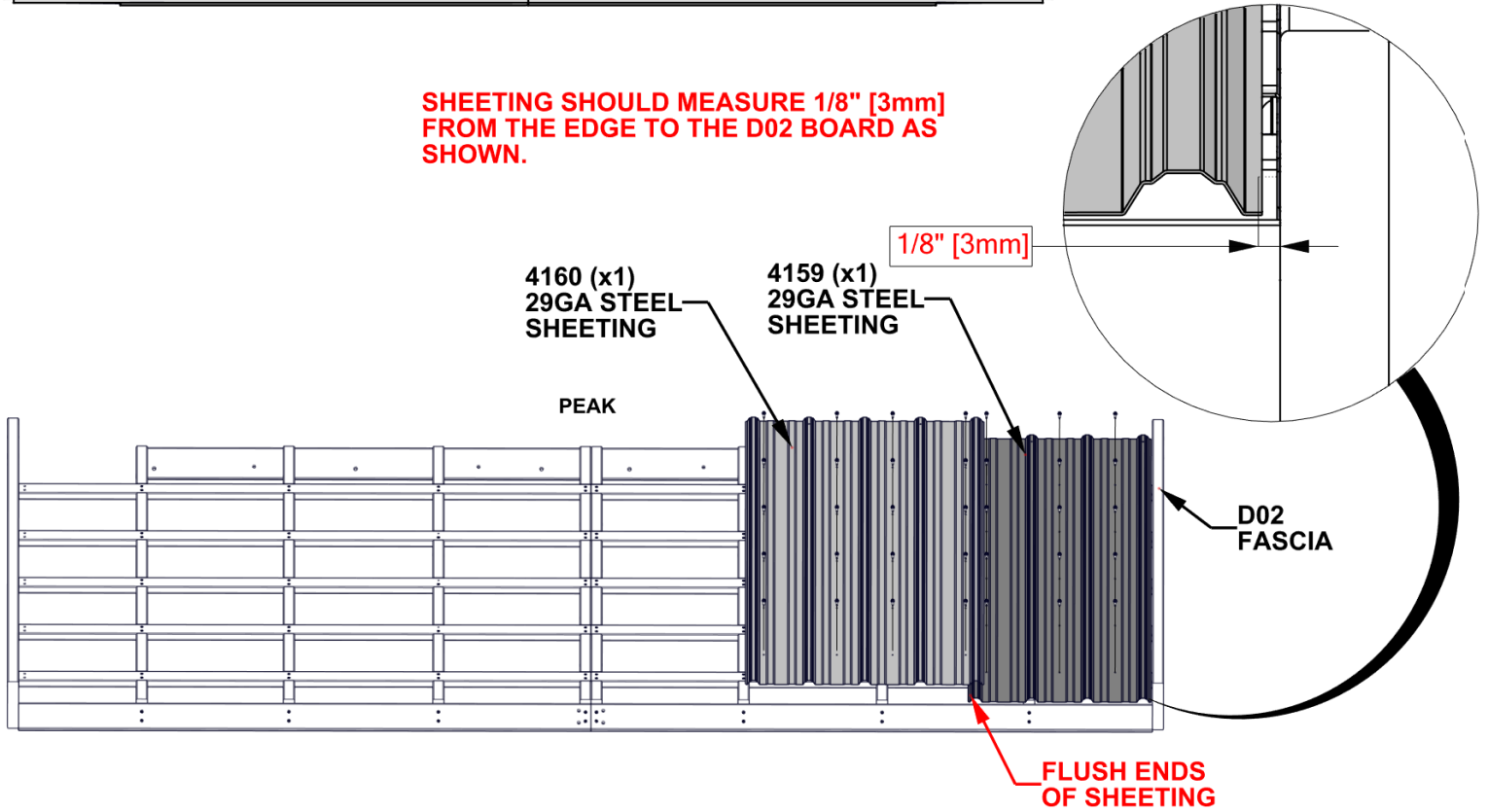

STEP 29 - ROOF PANEL 'A' ASSEMBLY

QTY	PART NUMBER	DESCRIPTION
30	H101117	SCREW WOODGRIP 10-16x3/4" BLK

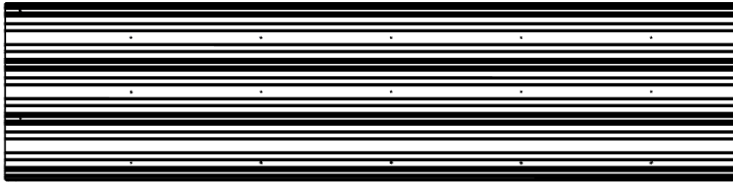

A4M04159 29GA STEEL SHEETING
(x1)



A4M04330 29GA STEEL SHEETING
(x1)

- PANEL A4M04330 WILL HAVE ONE HOLE LOCATED ON THE RIB CIRCLED IN RED ABOVE.

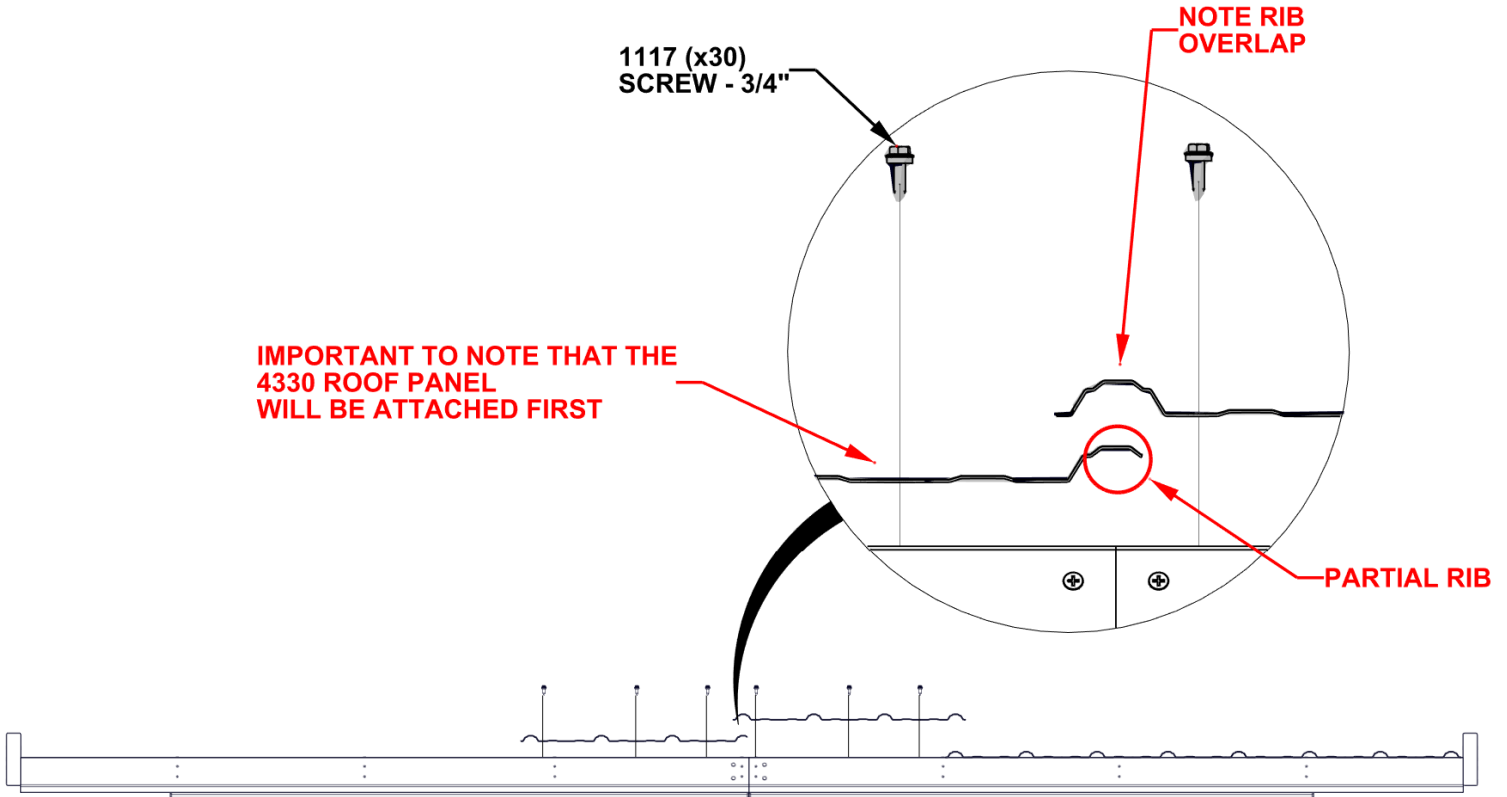

NOTE THAT A4M04330 SHEET HAS ONE HOLE ON THE RIB TOWARD THE PEAK

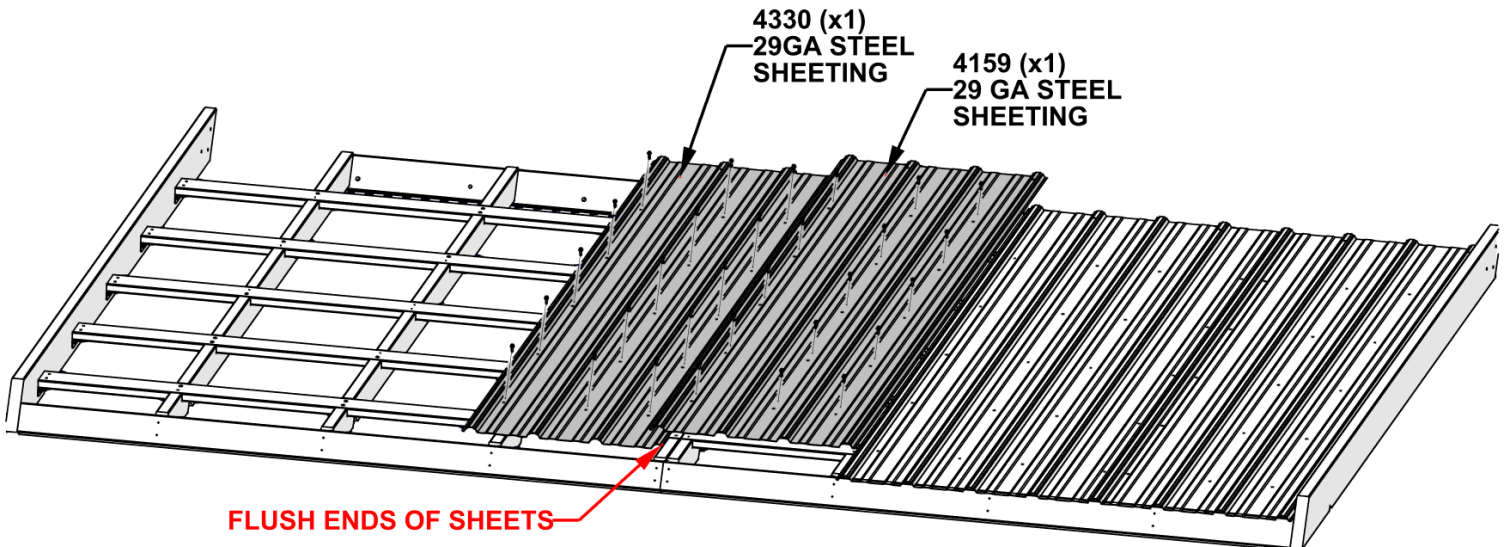

STEP 30 - ROOF PANEL 'A' ASSEMBLY

QTY	PART NUMBER	DESCRIPTION
35	H101117	SCREW WOODGRIP 10-16x3/4" BLK

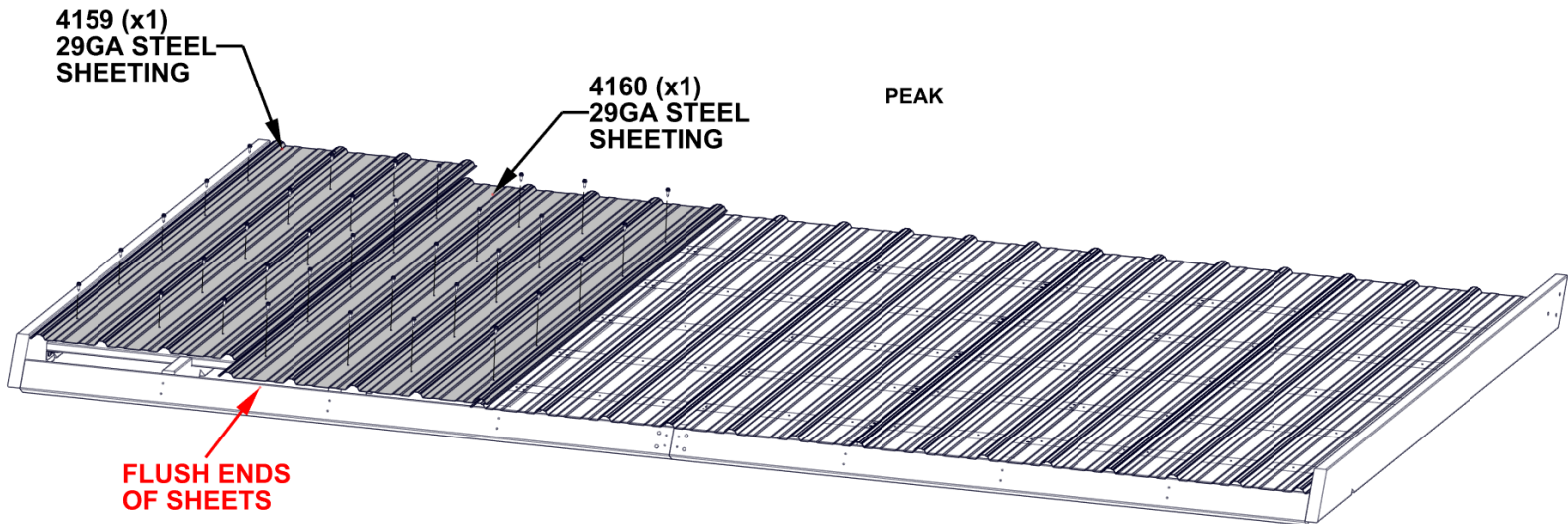
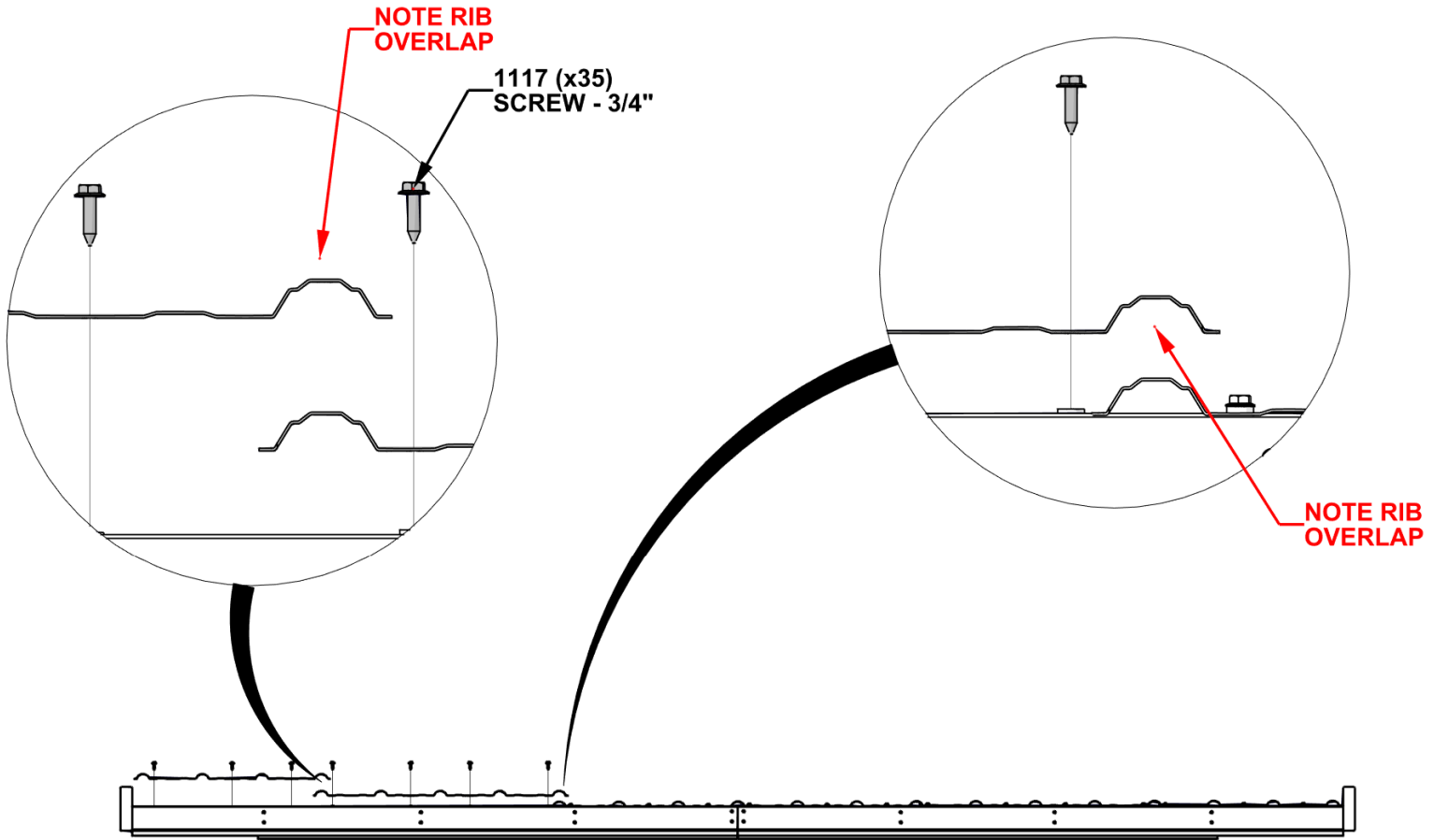
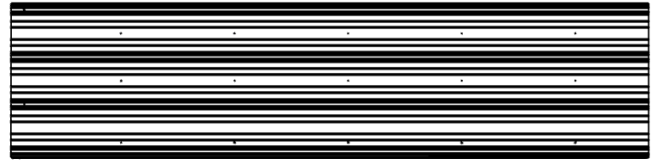

STEP 31 - ROOF PANEL 'A' ASSEMBLY

- SEPERATE ROOF PANEL FOR EASE OF ASSEMBLING.

- REMOVE HARDWARE AND SET ASIDE. IT WILL BE USED AGAIN AFTER BOTH SECTIONS ARE INSTALLED.

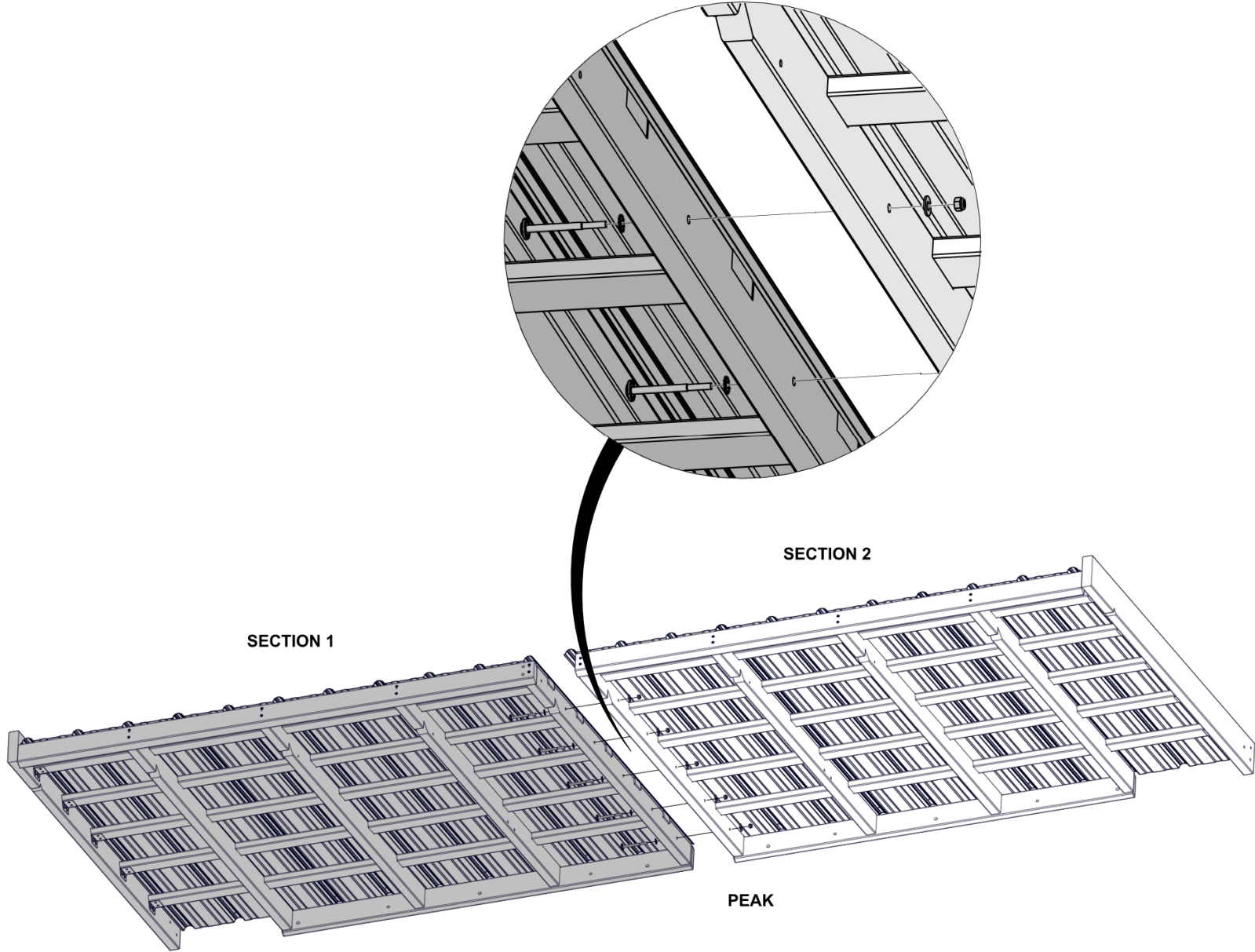

STEP 32A - ROOF PANEL 'B' ASSEMBLY

QTY	PART NUMBER	DESCRIPTION
16	H100201	SCREW PFH 8x2 1/2 BLK
4	H100379	T-NUT 5/16 BLK
16	H100391	SCREW PFH 8x2 BLK

- E11 RAFTER - W4L21895
(x2) 1 7/16"x3 3/8"x95 1/16" (36x86x2414)
- E02 RAFTER - W4L21178
(x2) 1 7/16"x3 3/8"x95 1/16" (36x86x2414)
- E08 RAFTER - W4L21799
(x2) 1 7/16"x3 3/8"x95 1/16" (36x86x2414)
- E07 RAFTER - W4L21561
(x2) 1 7/16"x3 3/8"x95 1/16" (36x86x2414)

- E03 TRIM BOARD - W4L21165
(x1) 1 7/16"x3 3/8"x72 5/16" (36x86x1836)
- E05 TRIM BOARD - W4L21564
(x1) 1 7/16"x3 3/8"x73 11/16" (36x86x1872)
- AD08 RIDGE SUPPORT - W4L21560
(x1) 15/16"x4"x58 1/2" (24x102x1486)
- AD06 RIDGE SUPPORT - W4L21181
(x1) 15/16"x4"x57 1/16" (24x102x1450)

- INSERT T-NUTS FIRST. FAILURE TO DO SO WILL RESULT IN INCOMPLETE ASSEMBLY.
- NOTE THAT CIRCLED ENDS OF AD06 AND AD08 BOARDS ARE LOCATED AWAY FROM MIDDLE RAFTERS AND HOLES ARE ORIENTATED TOWARD BOTTOM OF BOARD.
- ALIGN E05, E03, AD06, AND AD08 WITH PILOT HOLES IN RAFTER BOARDS.

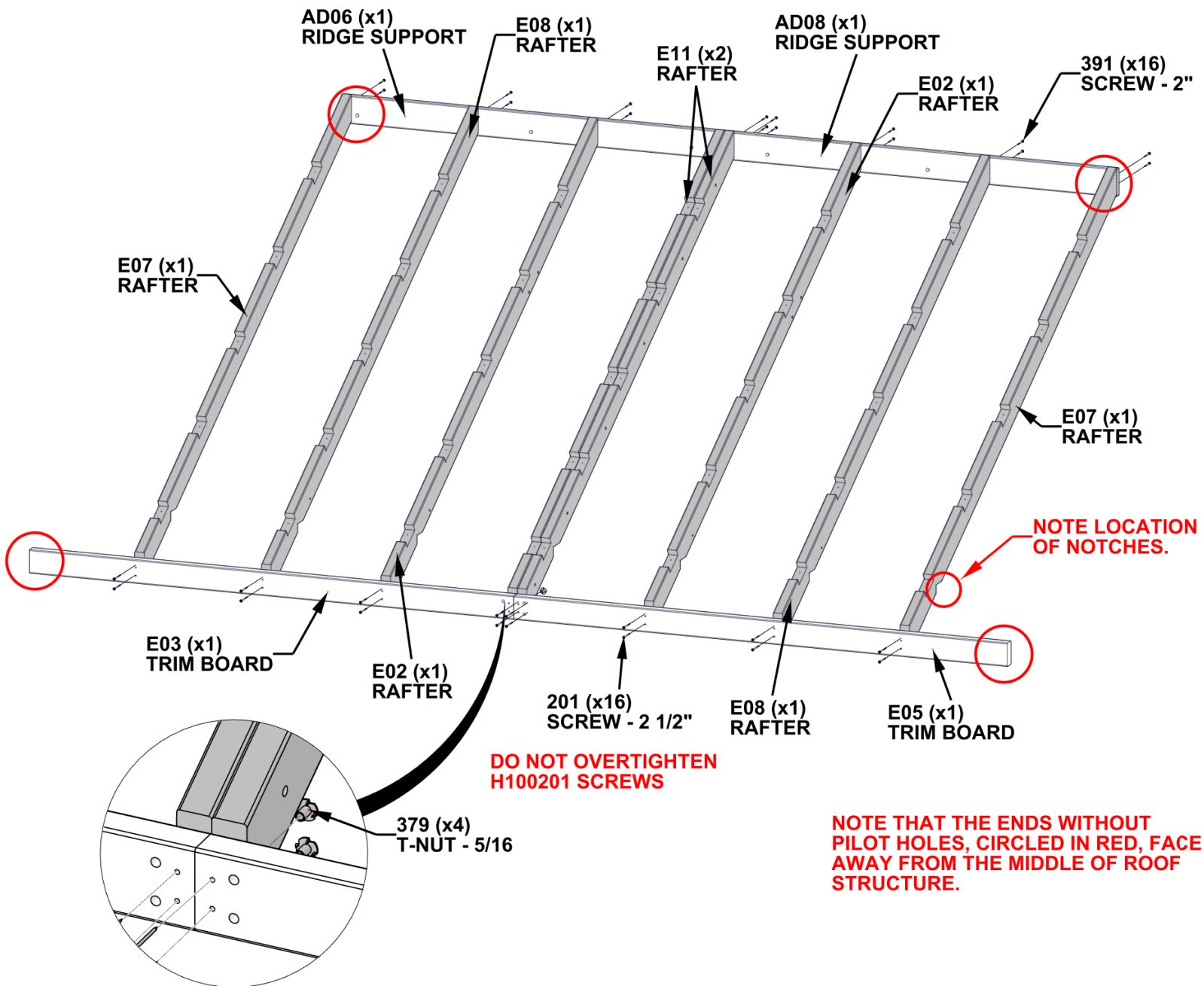

STEP 32B - ROOF PANEL 'B' ASSEMBLY

QTY	PART NUMBER	DESCRIPTION
6	H100198	WASHER LOCK EXT 8x19
6	H100478	WASHER FLAT 8x27 BLK
6	H100479	NUT LOCK 5/16 BLK
6	H100503	BOLT WH 5/16x3 1/2 BLK

- ALIGN HOLES IN MIDDLE RAFTERS AND FASTEN HARDWARE AS SHOWN.

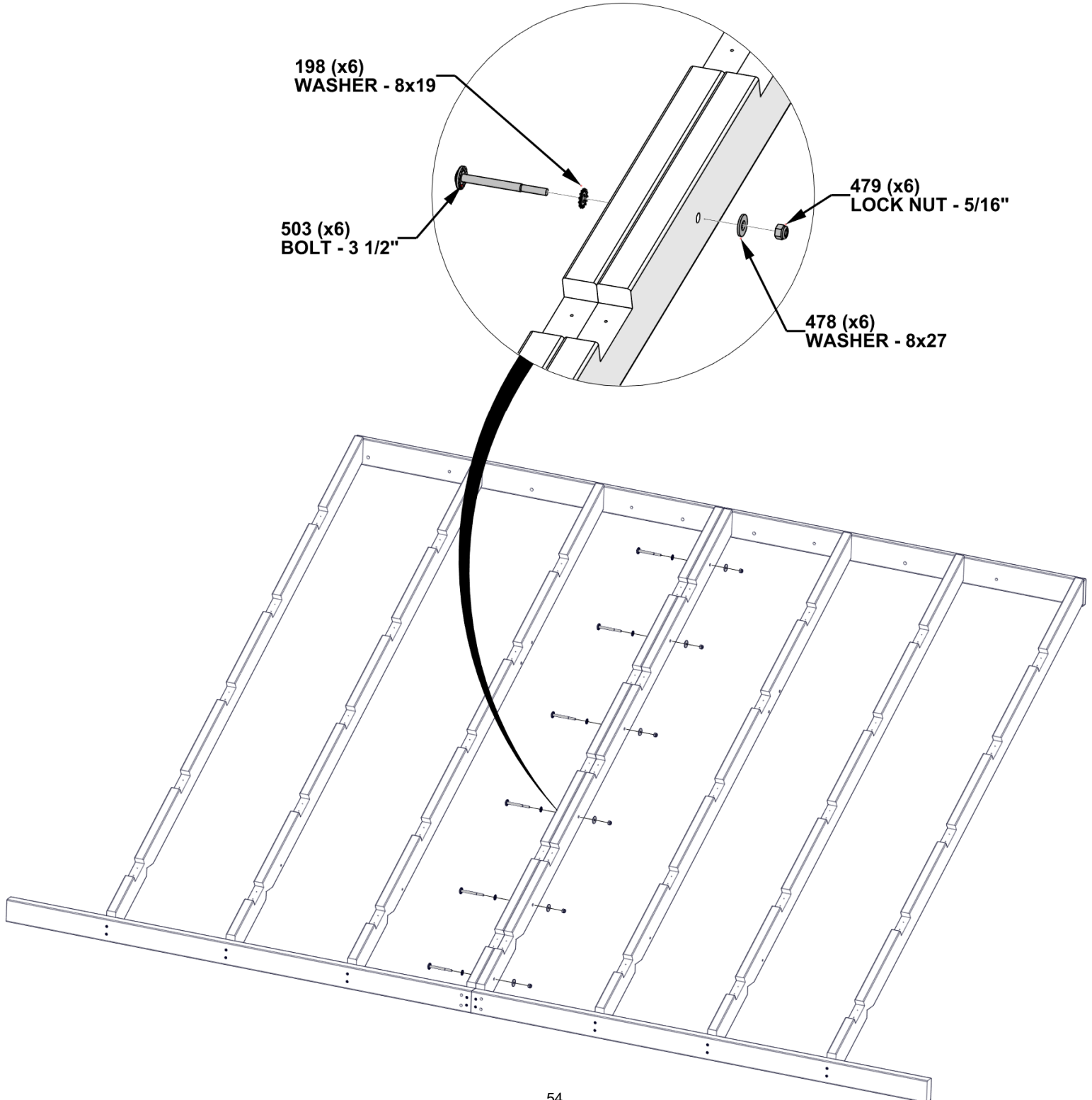

STEP 32C - ROOF PANEL 'B' ASSEMBLY

QTY	PART NUMBER	DESCRIPTION
20	H100171	BOLT WH 1/4x1 BLK
20	H100398	TNUT-1/4" BLK

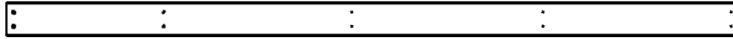

H01 PURLIN - W4L21166
(x5) 15/16"x3 3/8"x73 5/8" (24x86x1870)

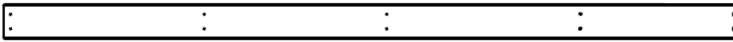

H02 PURLIN - W4L21557
(x5) 15/16"x3 3/8"x72 3/16" (24x86x1834)

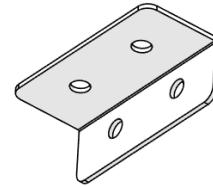

A4M04154 PURLIN SUPPORT BRACKET
(x10)

- INSERT T-NUTS FIRST.

- NOTE ORIENTATION OF 4154 BRACKET, LONG SECTION FASTENS TO PURLIN BOARD.
- COMPLETE THIS STEP 5 TIMES.

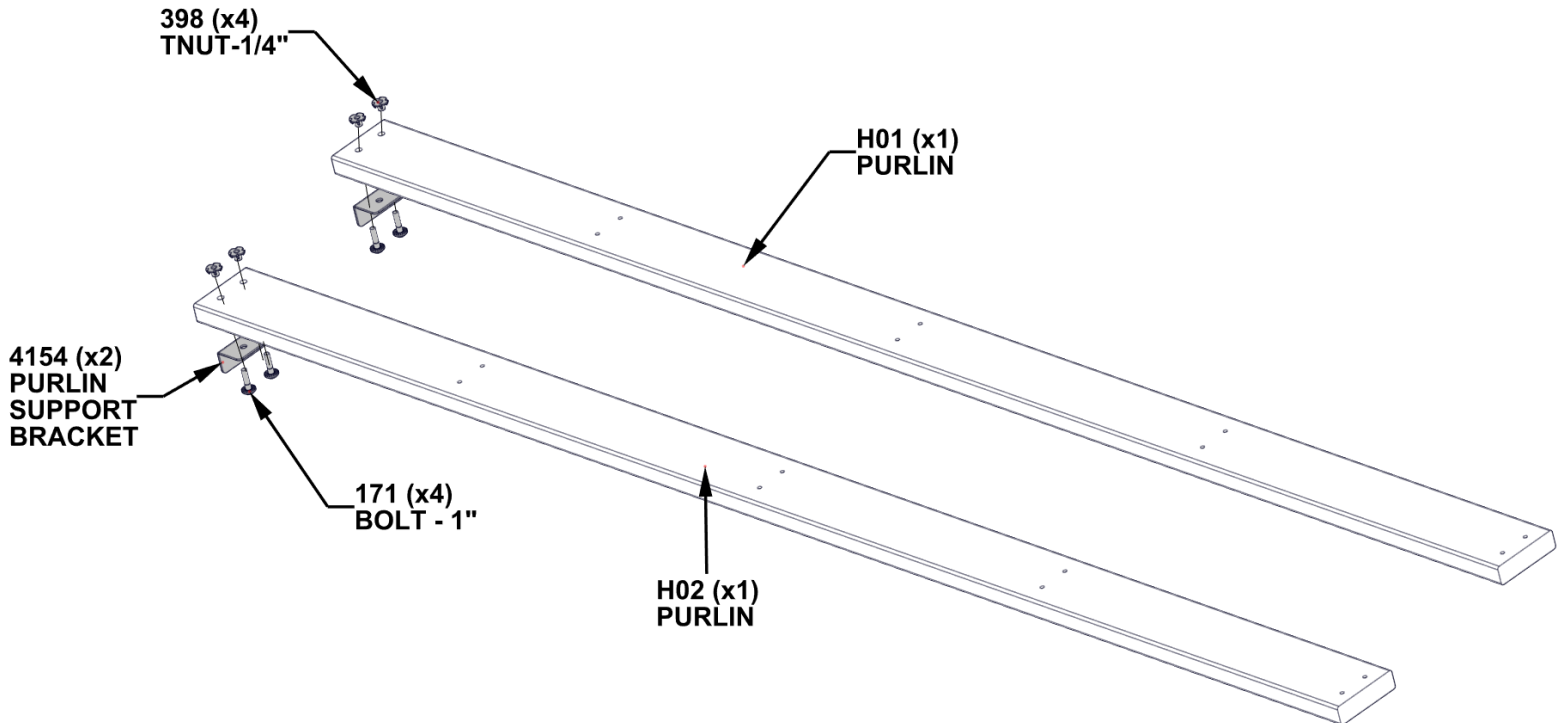

STEP 32D - ROOF PANEL 'B' ASSEMBLY

QTY	PART NUMBER	DESCRIPTION
80	H100391	SCREW PFH 8x2 BLK

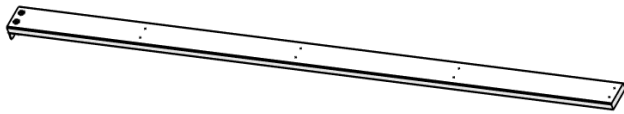

H01 PURLIN ASSEMBLY - STEP 32C

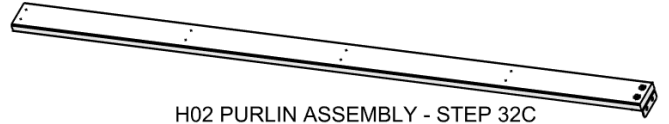

H02 PURLIN ASSEMBLY - STEP 32C

- INSERT T-NUTS FIRST.

- ALIGN PURLINS WITH PILOT HOLES IN RAFTERS

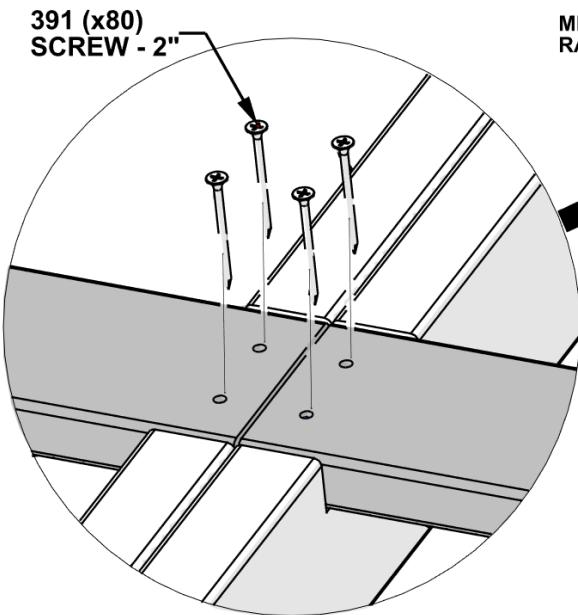
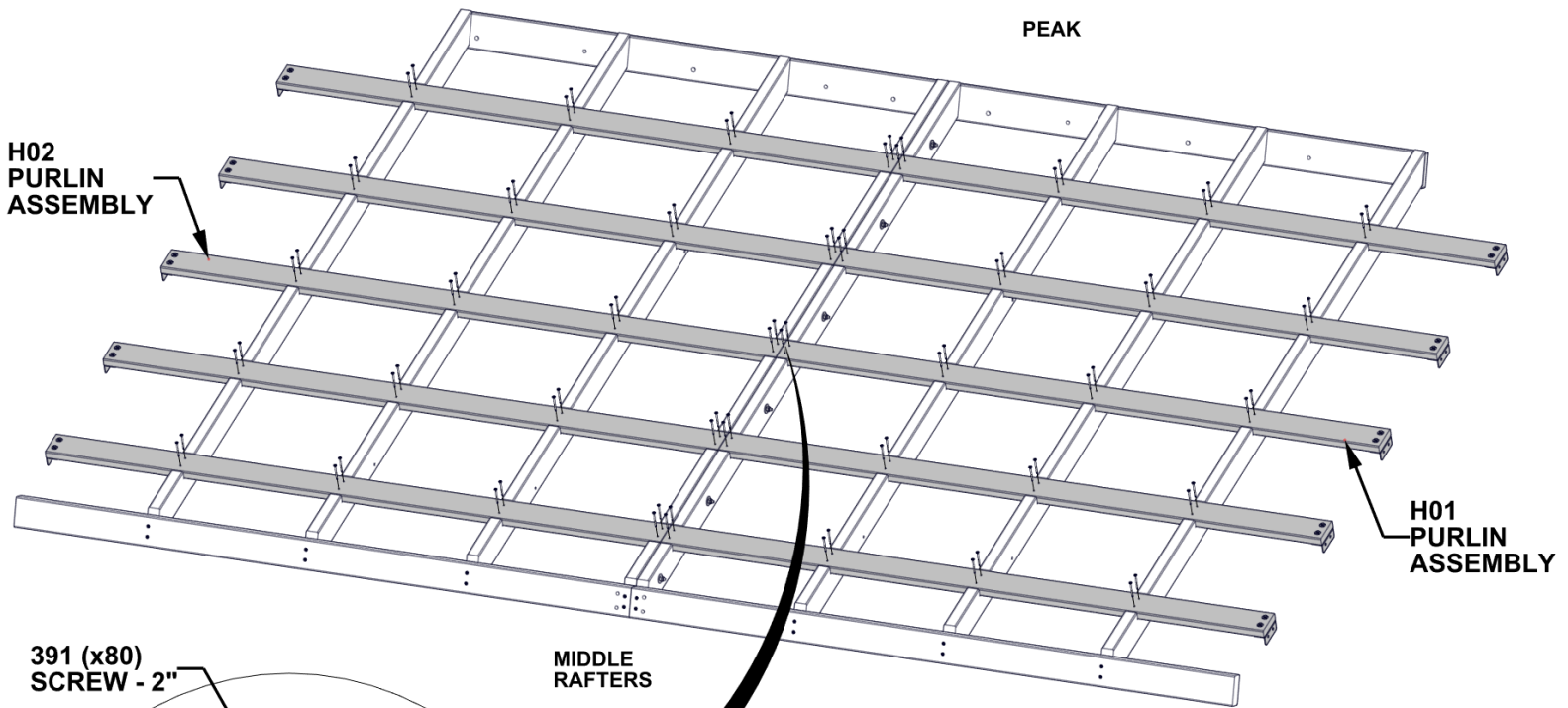

15-1/8" [384mm]

OVERHANG DISTANCE FOR PURLINS IS 15-1/8" [384mm] FROM END OF PURLIN TO RAFTER BOARD ON BOTH ENDS

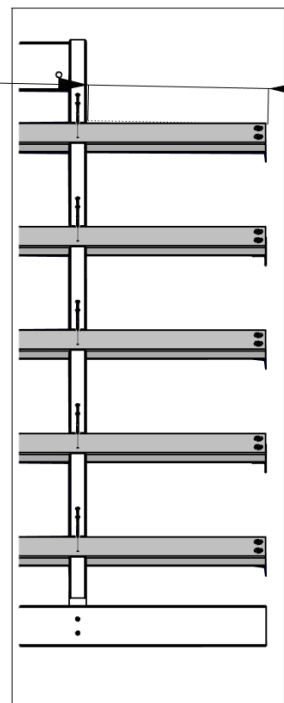

STEP 32E - ROOF PANEL 'B' ASSEMBLY

QTY	PART NUMBER	DESCRIPTION
6	H100379	T-NUT 5/16 BLK
20	H100460	LAG SCREW WH 1/4x1 BLK

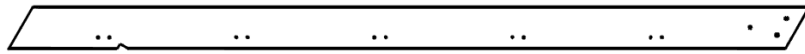

D01 FASCIA - W4L21164
(x1) 1 7/16"x5 1/4"x100" (36x134x2540)

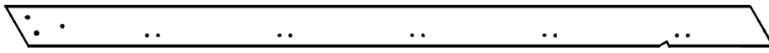

D02 FASCIA - W4L21175
(x1) 1 7/16"x5 1/4"x100" (36x134x2540)

- INSERT T-NUTS FIRST.

- ALIGN D01 AND D02 PILOT HOLES WITH HOLES IN 4154 BRACKETS.

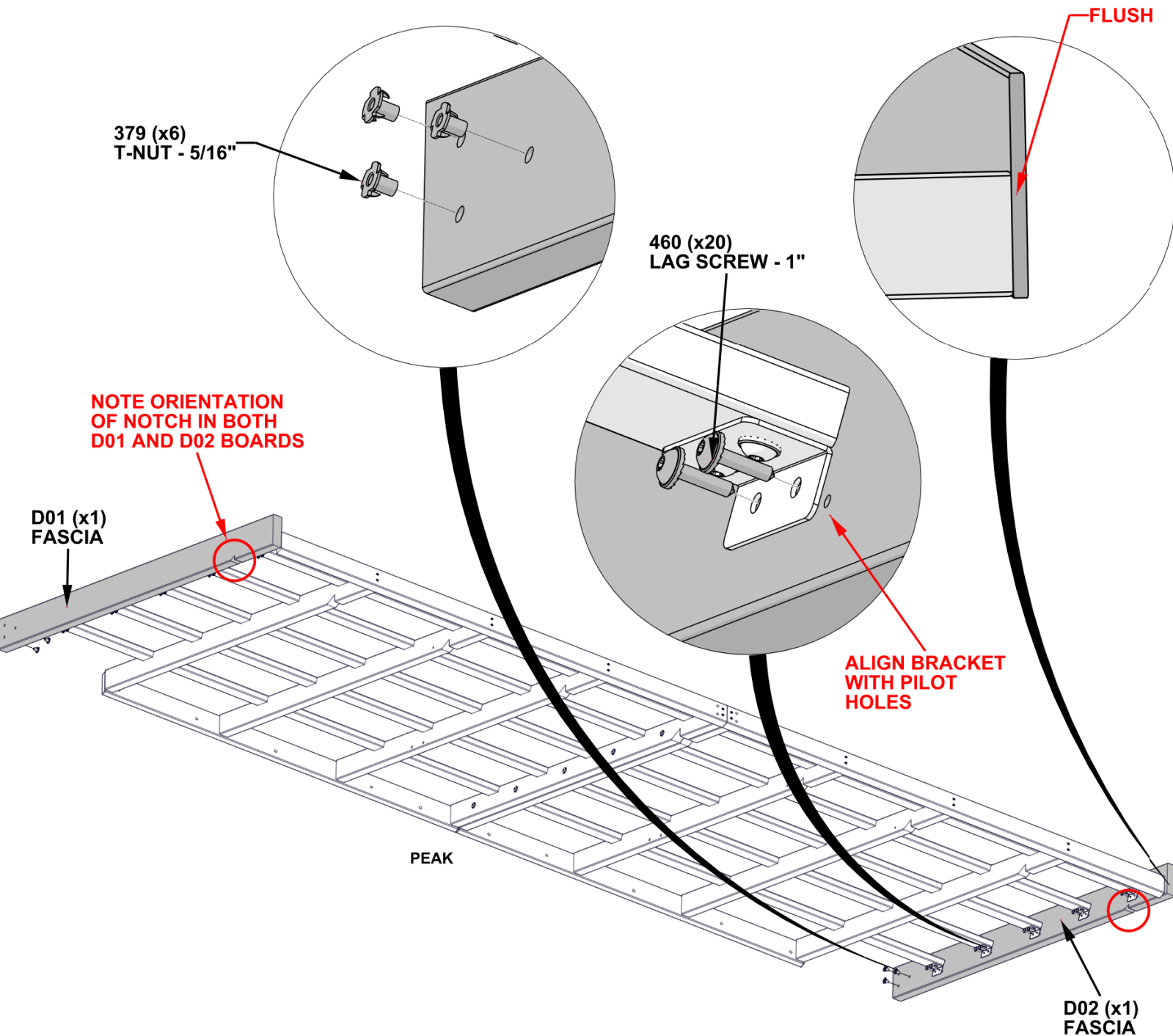

STEP 32F - ROOF PANEL 'B' ASSEMBLY

QTY	PART NUMBER	DESCRIPTION
8	H100797	SCREW PWH 8x1 BLK

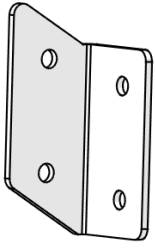

A4M04907 FASCIA BRACKET
(x1)

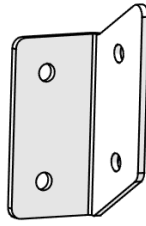

A4M04908 FASCIA BRACKET
(x1)

- ALIGN BRACKET 1/4" [6mm] FROM TOP OF TRIM BOARD AS SHOWN.
- ATTACH FASCIA BRACKET 4907 AND 4908 BY DRILLING A 1/8" [3mm] PILOT HOLE AND FASTENING WITH 797 SCREWS.

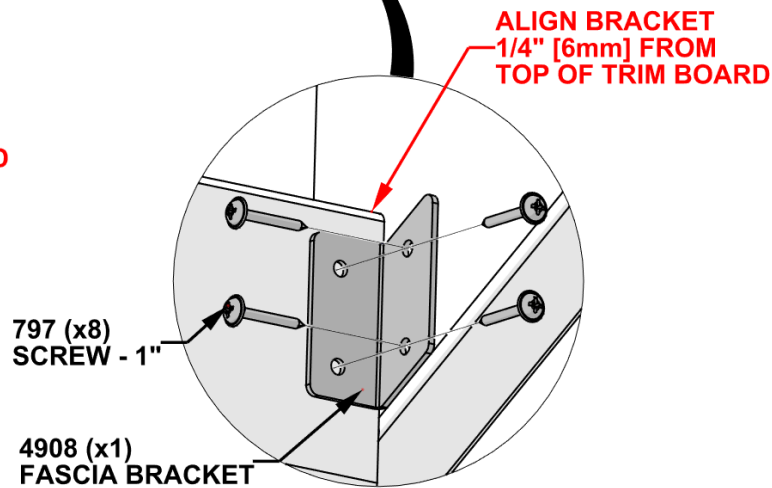
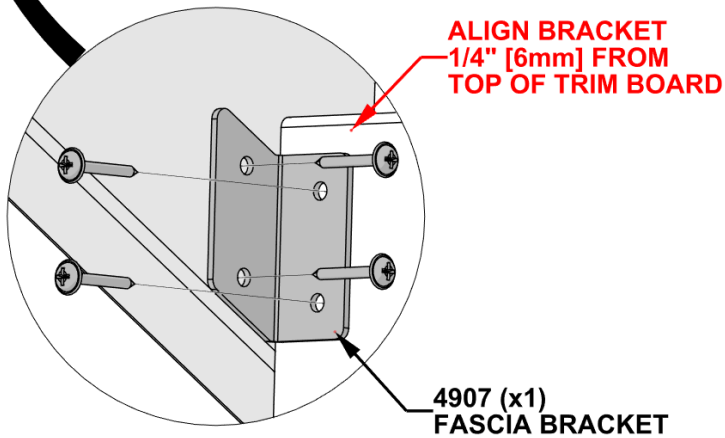
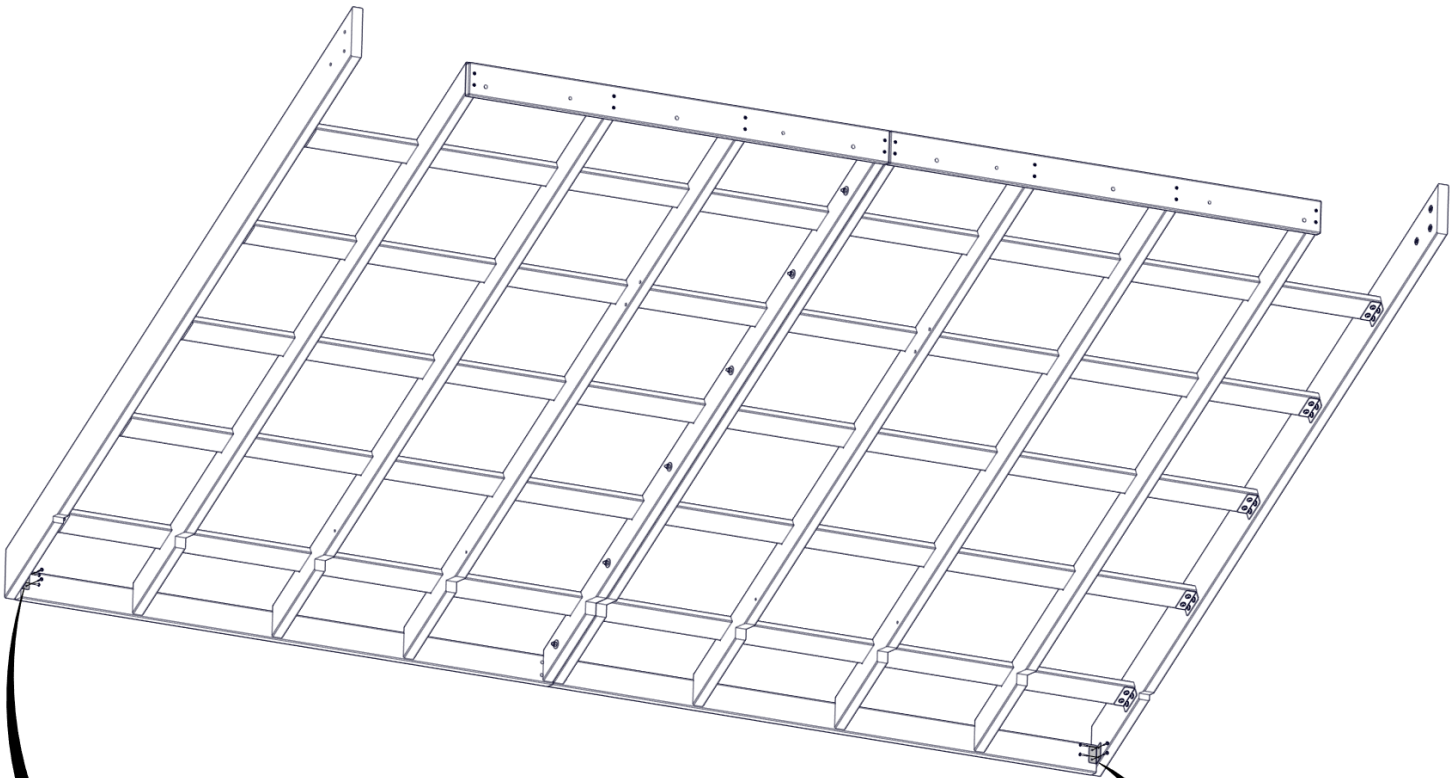

STEP 32G - ROOF PANEL 'B' ASSEMBLY

- CRITICAL:**
- SQUARE UNIT BEFORE PROCEEDING TO NEXT STEPS.
 - THE BELOW DIMENSIONS ARE CRITICAL TO THE FINAL ROOF ASSEMBLY.
 - MEASUREMENTS BELOW SHOULD BE HELD WITH IN +/- 1/4" [6mm].
 - MEASUREMENTS OUTSIDE OF TOLERANCE WILL LEAD TO THE INABILITY TO ASSEMBLE THE ROOF.

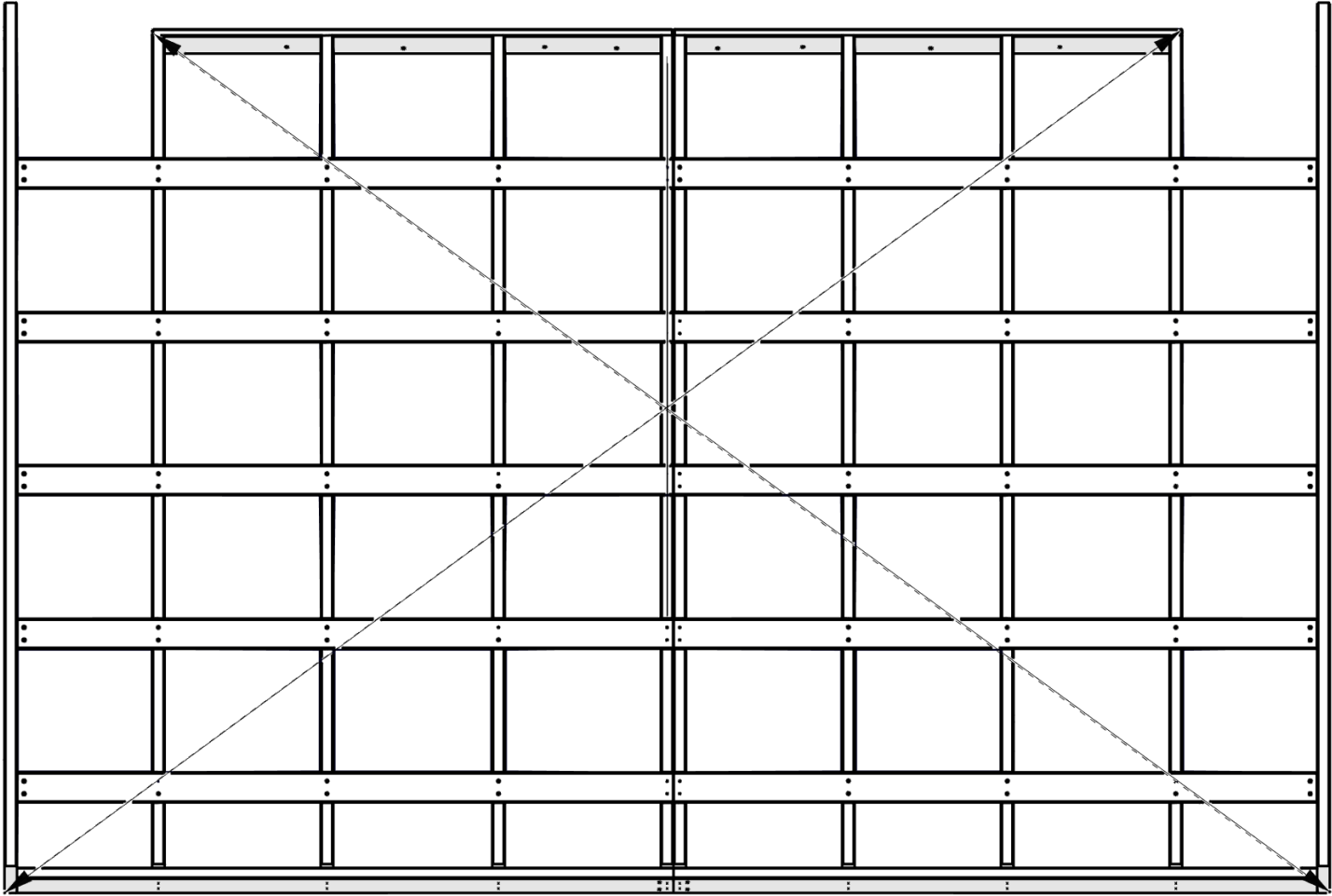

13-7 13/16" [4161mm]

13-7 13/16" [4161mm]

TIP : LOOSEN HARDWARE TO ADJUST FOR SQUARING IF NEEDED

STEP 33 - ROOF PANEL 'B' ASSEMBLY

- USE THIS PAGE TO FAMILIARIZE YOURSELF WITH THE ROOF PANEL AND ASSIST YOU IN STEPS 34-36.
- REMOVE PROTECTIVE BLUE FILM.
- START AT THE END INDICATED AND ASSEMBLE IN THE DIRECTION OF THE ARROW
- **GLOVES SHOULD BE WORN WHEN HANDLING ROOF PANELS: EDGES ARE SHARP.**
- **START BY PLACING FIRST SHEET 1/8" [3mm] FROM D02 FASCIA BOARD, THE LAST SHEET SHOULD ALIGN CLOSE TO THE EDGE OF THE D01 FASCIA BOARD.**

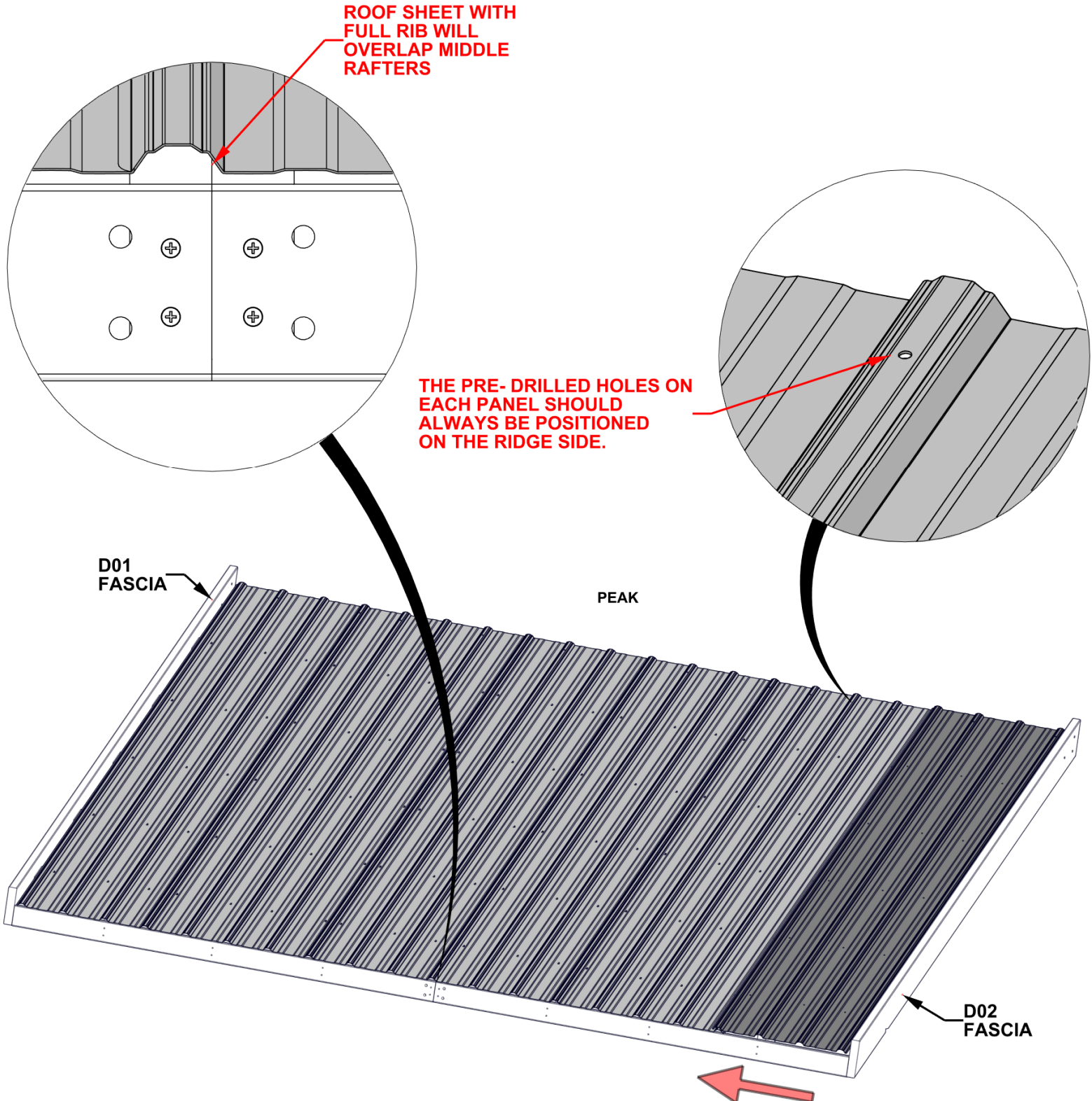

STEP 34 - ROOF PANEL 'B' ASSEMBLY

QTY	PART NUMBER	DESCRIPTION
35	H101117	SCREW WOODGRIP 10-16x3/4" BLK



A4M04160 29GA STEEL SHEETING
(x1)



A4M04159 29GA STEEL SHEETING
(x1)

- MAKE SURE ROOF PANEL IS SQUARE BEFORE MOVING ON.

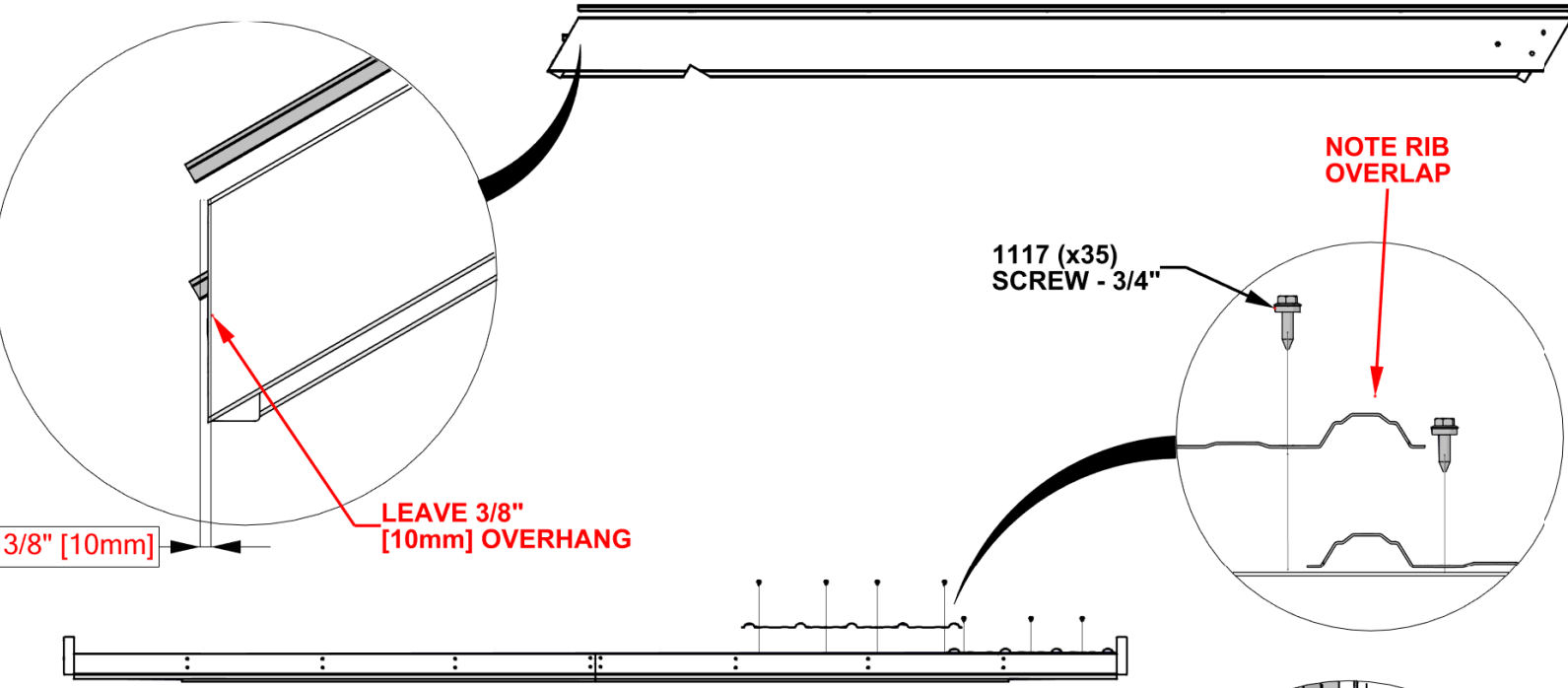

SHEETING SHOULD MEASURE 1/8" [3mm] FROM THE EDGE TO THE D02 BOARD AS SHOWN.

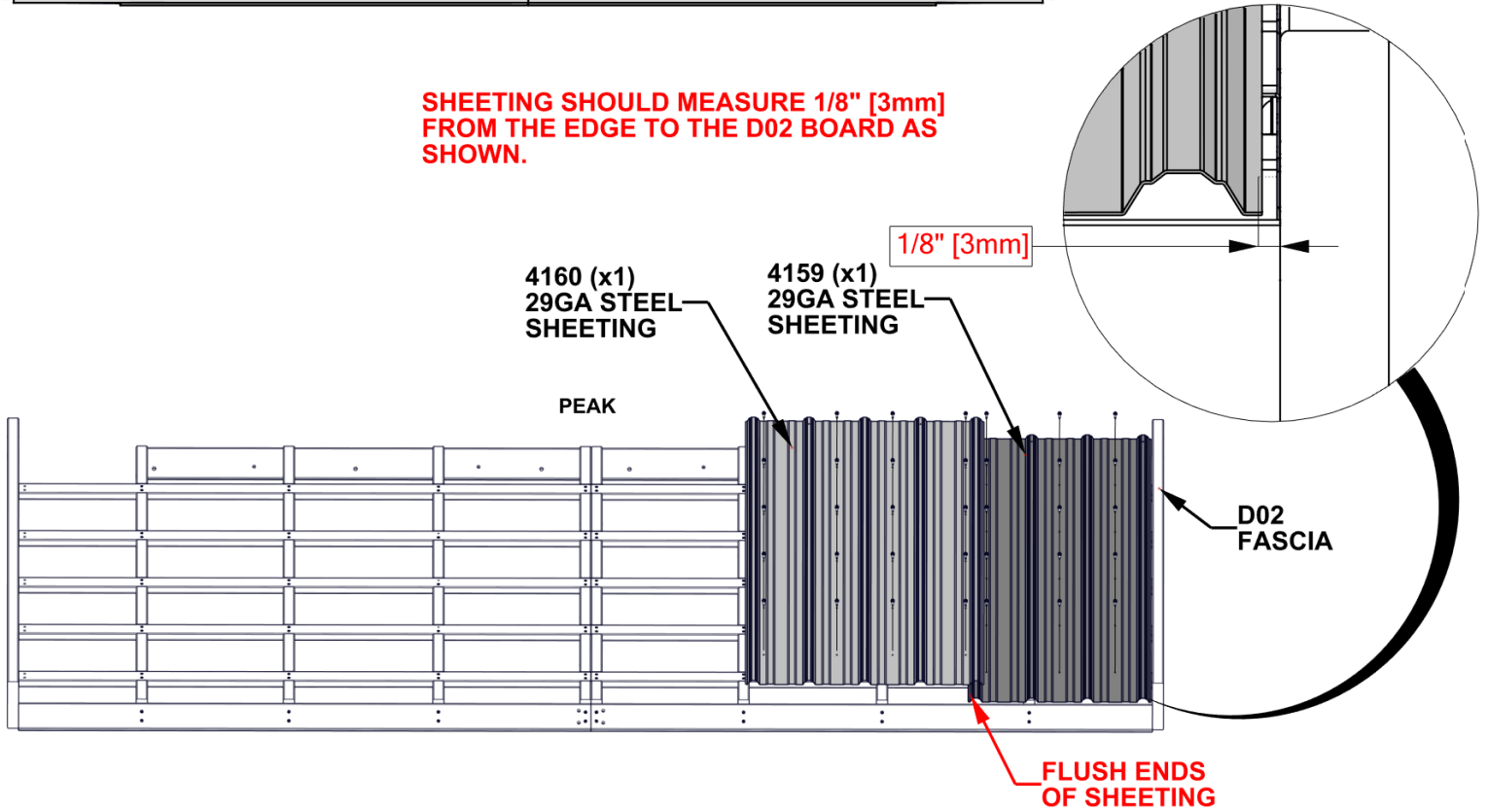

STEP 35 - ROOF PANEL 'B' ASSEMBLY

QTY	PART NUMBER	DESCRIPTION
30	H101117	SCREW WOODGRIP 10-16x3/4" BLK

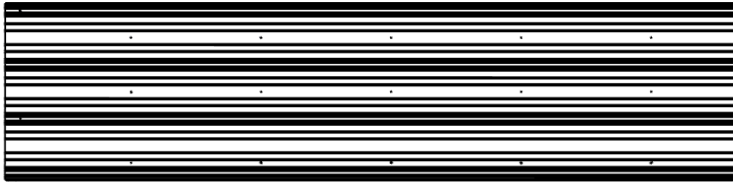

A4M04159 29GA STEEL SHEETING
(x1)

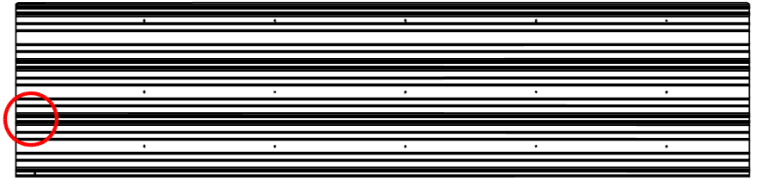

A4M05348 29GA STEEL SHEETING
(x1)

- PANEL A4M05348 WILL HAVE ONE HOLE LOCATED ON THE RIB CIRCLED IN RED ABOVE.

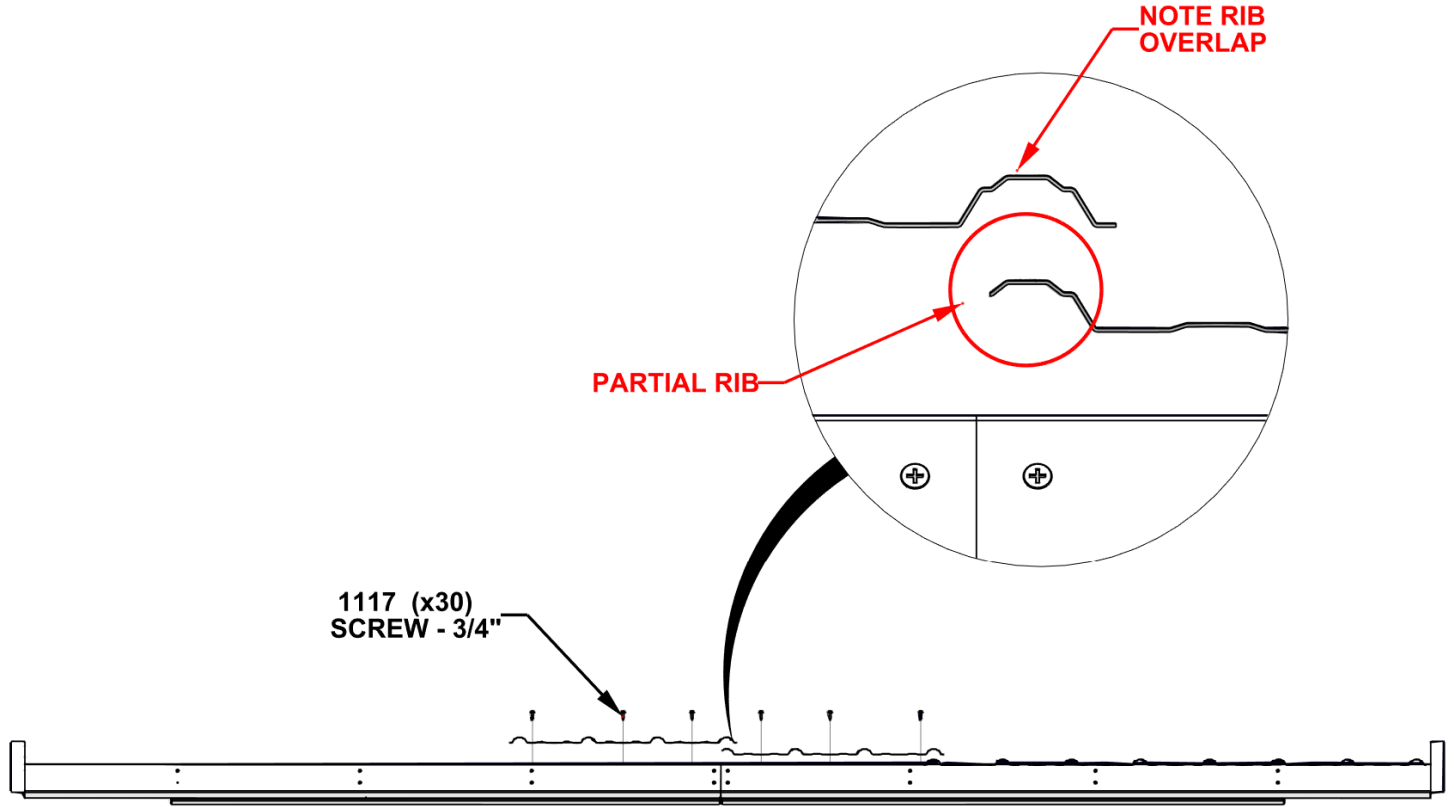

NOTE THAT A4M05348 SHEET HAS ONE HOLE ON THE RIB TOWARD THE PEAK

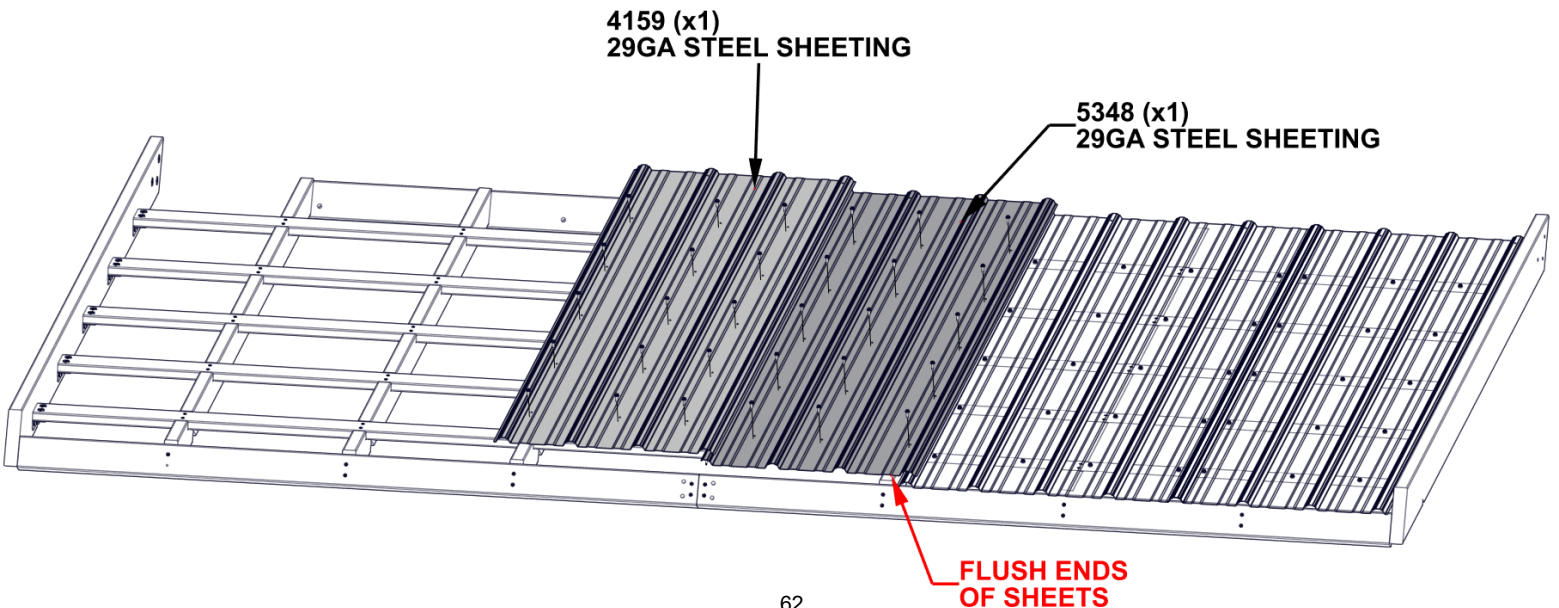

STEP 36 - ROOF PANEL 'B' ASSEMBLY

QTY	PART NUMBER	DESCRIPTION
35	H101117	SCREW WOODGRIP 10-16x3/4" BLK

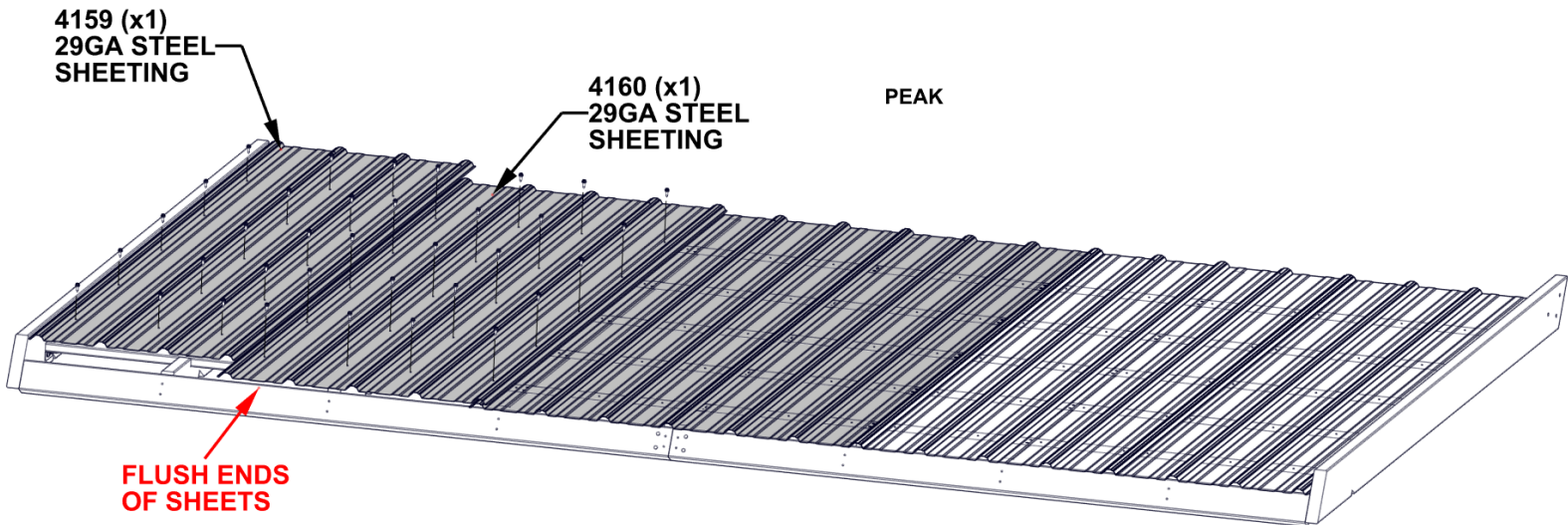
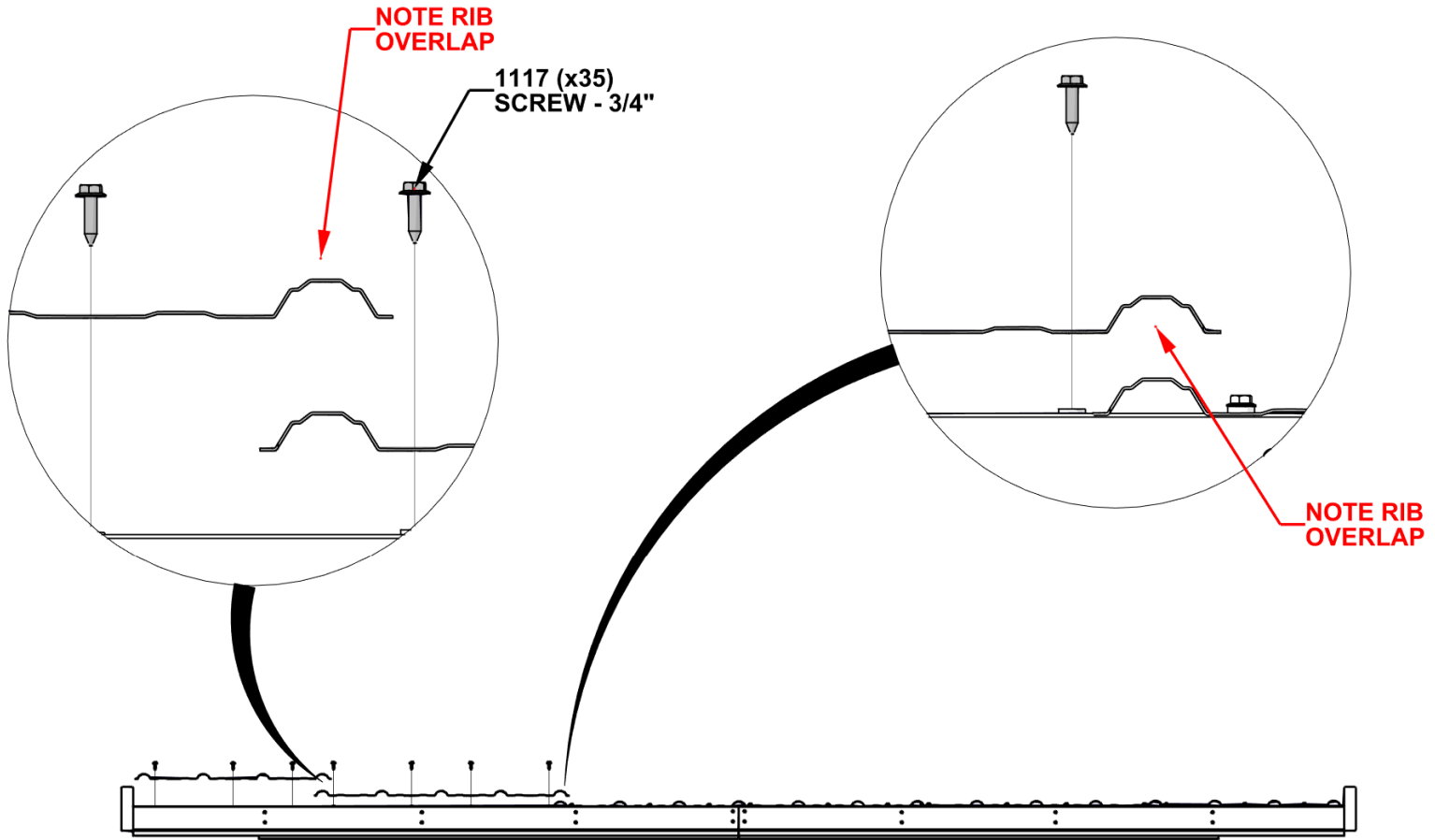
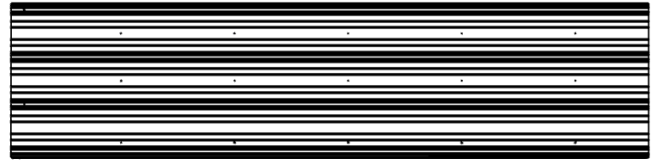

STEP 37 - ROOF PANEL 'B' ASSEMBLY

- SEPERATE ROOF PANEL FOR EASE OF ASSEMBLING.
- REMOVE HARDWARE AND SET ASIDE. IT WILL BE USED AGAIN AFTER BOTH SECTIONS ARE INSTALLED.

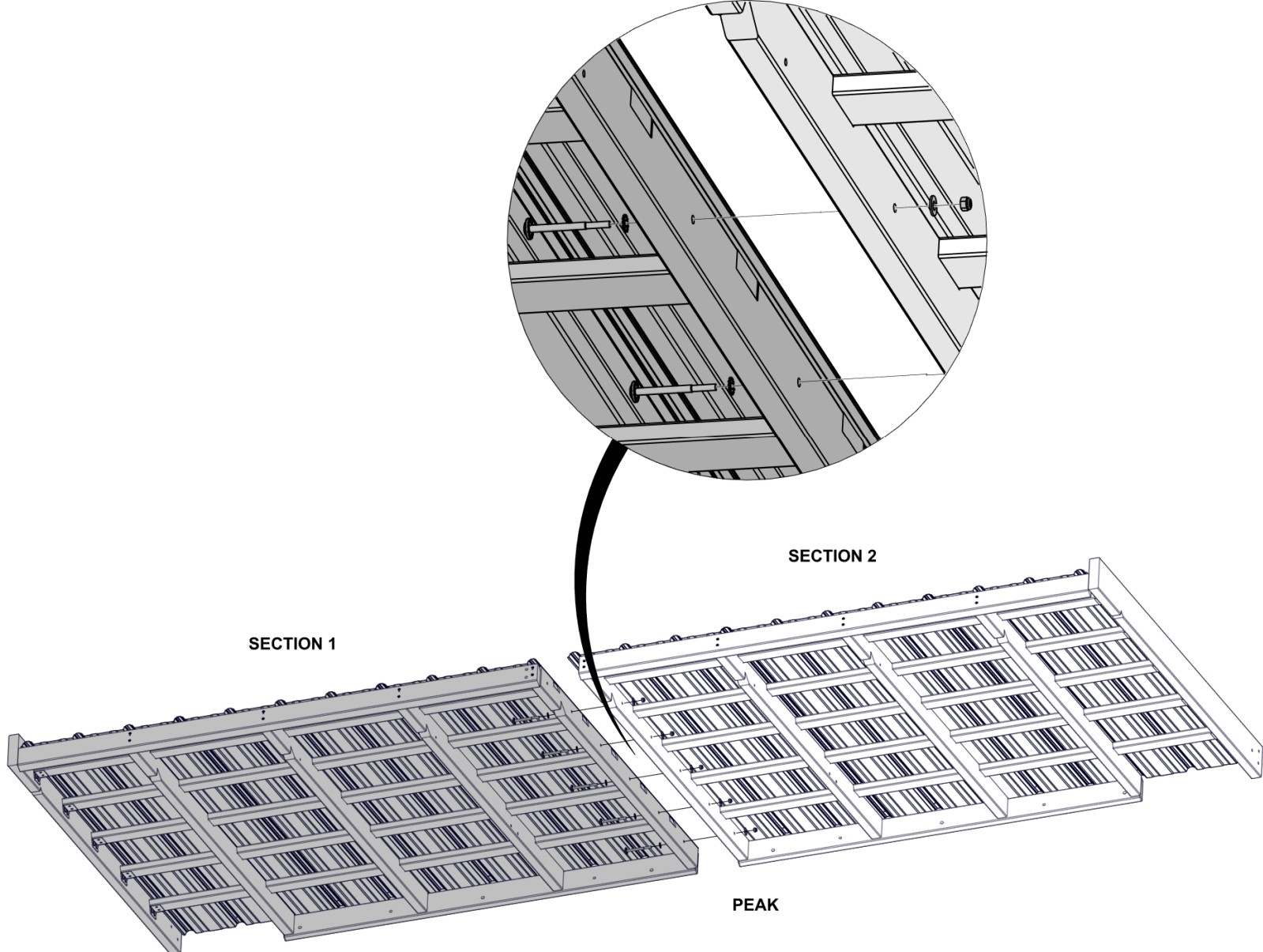

STEP 38 - ROOF ASSEMBLY

QTY	PART NUMBER	DESCRIPTION
2	H100195	BOLT WH 5/16x2 3/4 BLK
2	H100198	WASHER LOCK EXT 8x19

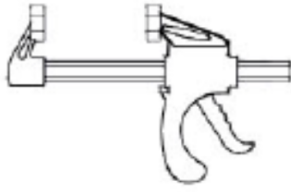

A6P00460 6" QUICK RELEASE CLAMP

- HAND TIGHTEN HARDWARE.

- ADDITIONAL PEOPLE ARE HELPFUL FOR THIS STEP.
- SLIDE ROOF PANEL ALONG GABLE BEAM.
- USE A6P00460 QUICK RELEASE CLAMPS IF NEEDED.

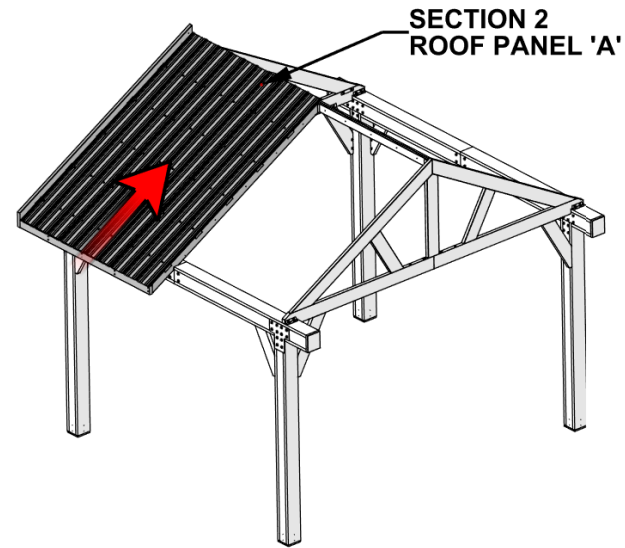

SECTION 2
ROOF PANEL 'A'

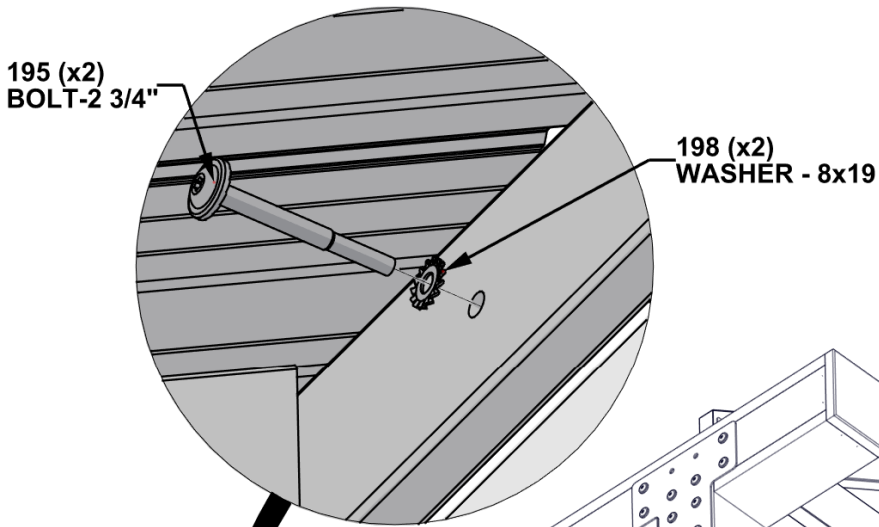

195 (x2)
BOLT-2 3/4"

198 (x2)
WASHER - 8x19

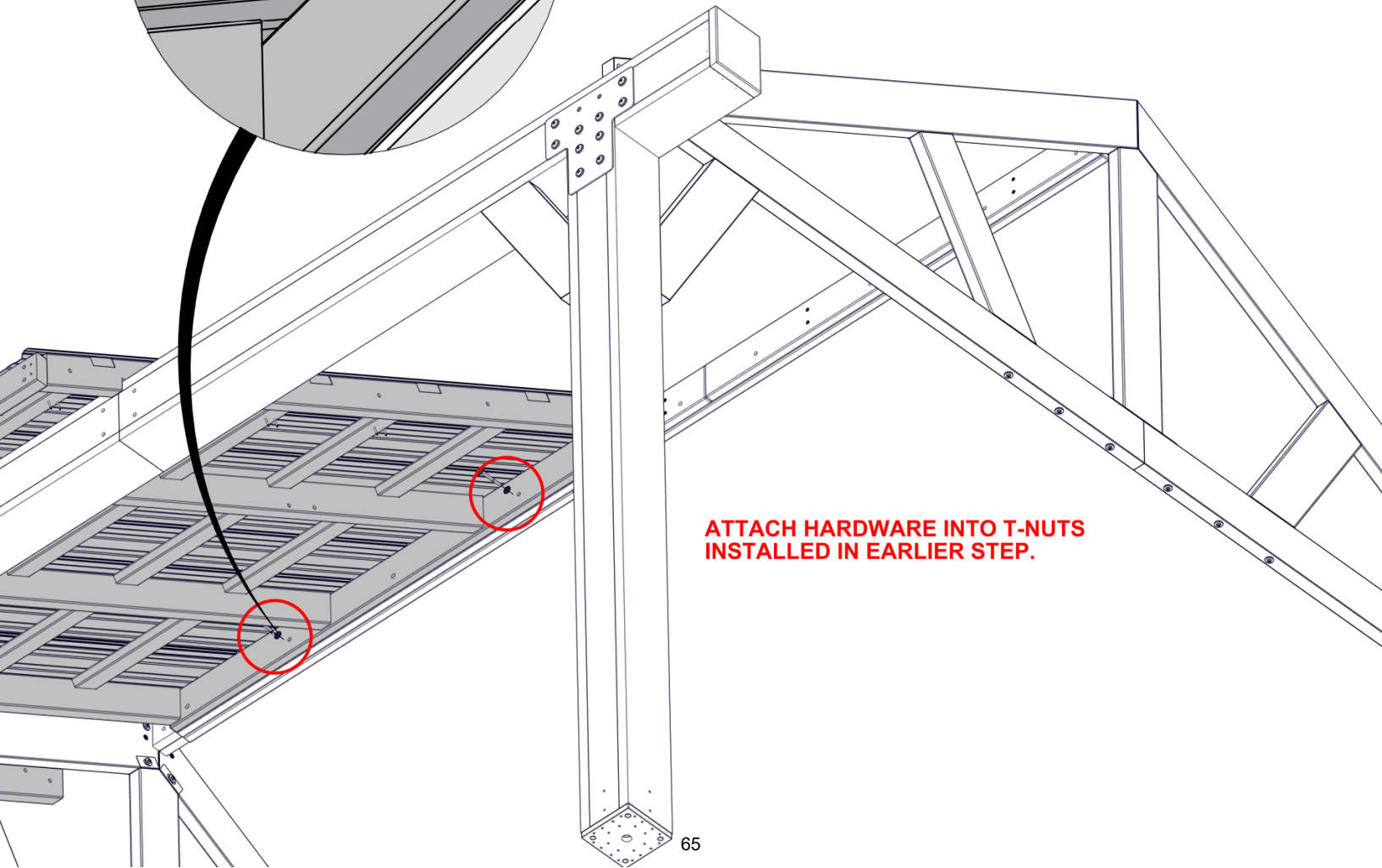

**ATTACH HARDWARE INTO T-NUTS
INSTALLED IN EARLIER STEP.**

STEP 39 - ROOF ASSEMBLY

QTY	PART NUMBER	DESCRIPTION
3	H100198	WASHER LOCK EXT 8x19
3	H100479	NUT LOCK 5/16 BLK
3	H100534	BOLT WH 5/16x4 1/2 BLK
3	H100630	WASHER FLAT 8x19 BLK

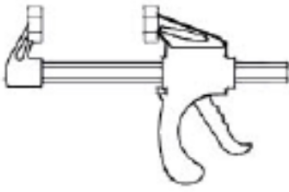

A6P00460 6" QUICK RELEASE CLAMP

- HAND TIGHTEN HARDWARE.

- ADDITIONAL PEOPLE ARE HELPFUL FOR THIS STEP.
- SLIDE ROOF PANEL ALONG GABLE BEAM.
- USE A6P00460 QUICK RELEASE CLAMPS IF NEEDED.

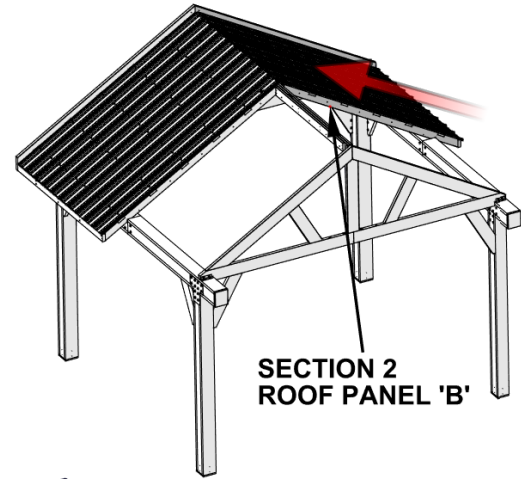

SECTION 2
ROOF PANEL 'B'

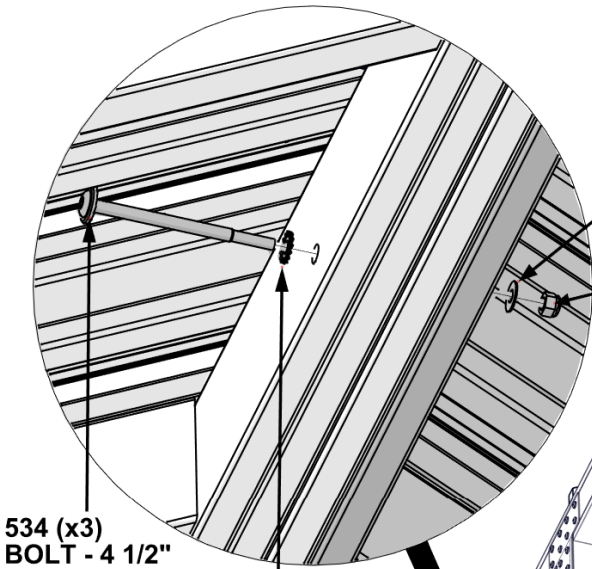

534 (x3)
BOLT - 4 1/2"

198 (x3)
WASHER - 8x19

630 (x3)
WASHER - 8x19

479 (x3)
LOCK NUT - 5/16"

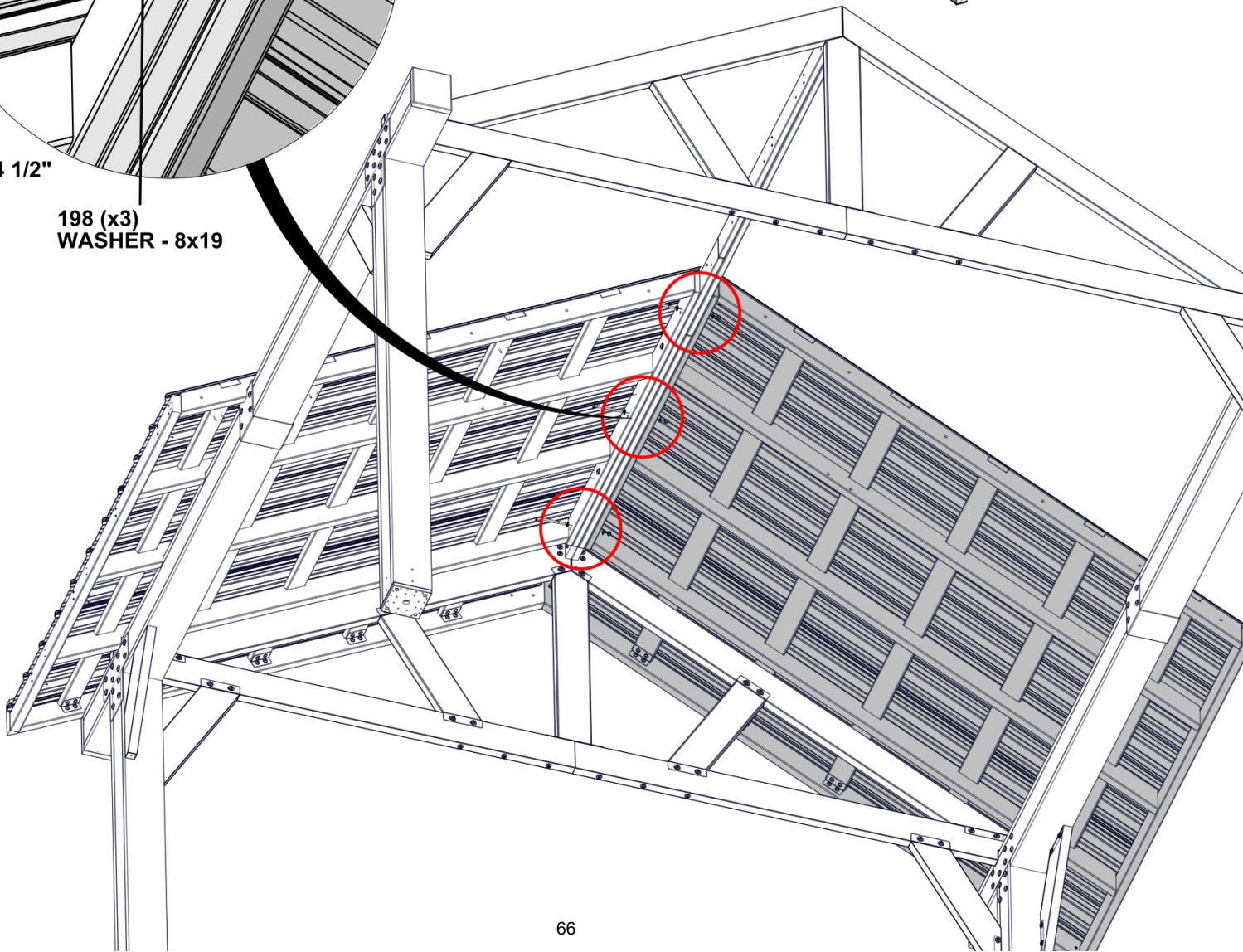

STEP 40 - ROOF ASSEMBLY

QTY	PART NUMBER	DESCRIPTION
6	H100459	BOLT WH 5/16x1 1/4 BLK

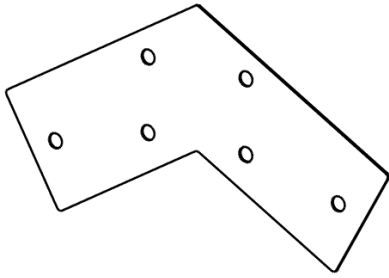

A4M02086 GABLE BRACKET
(x1)

- FASTEN HARDWARE INTO T-NUTS INSTALLED IN D01 AND D02 BOARDS.
- HAND TIGHTEN HARDWARE.

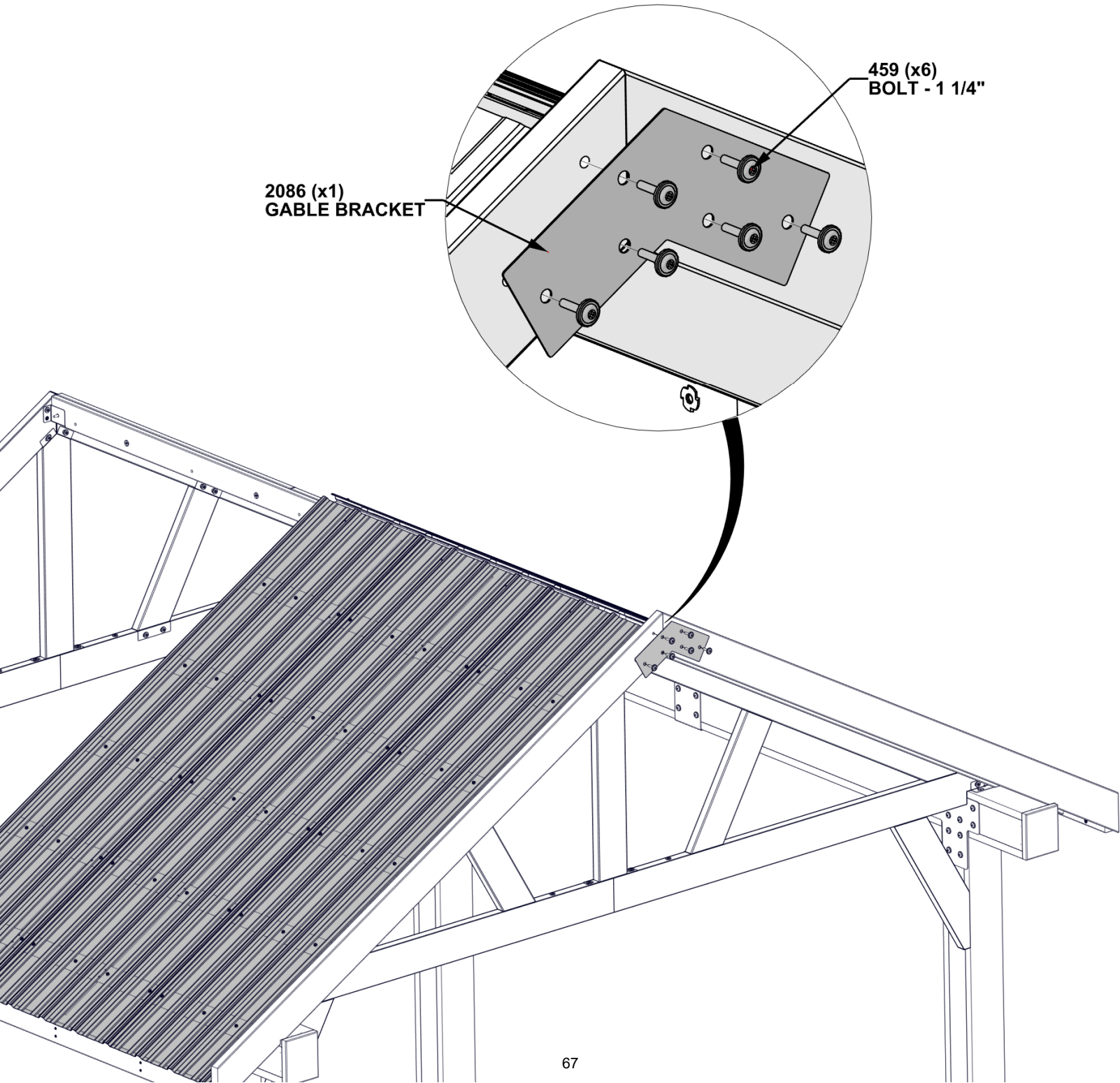

STEP 41 - ROOF ASSEMBLY

CRITICAL:

- IT IS IMPORTANT THAT THE PANELS ARE INSTALLED AS SHOWN.
- PARTIAL RIB MUST BE INSTALLED UNDER FULL RIB.
- FAILURE TO DO SO WILL RESULT IN LEAKING.

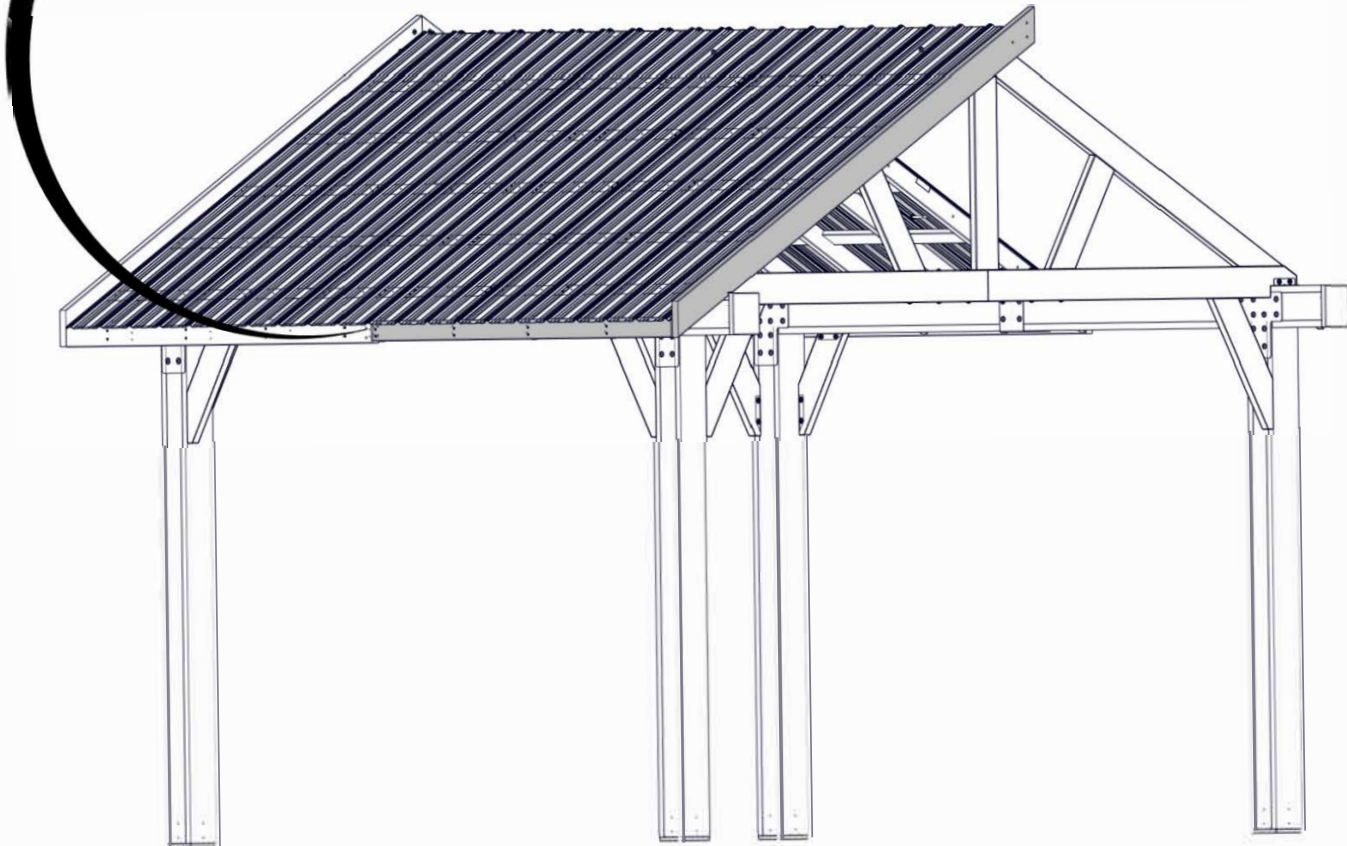
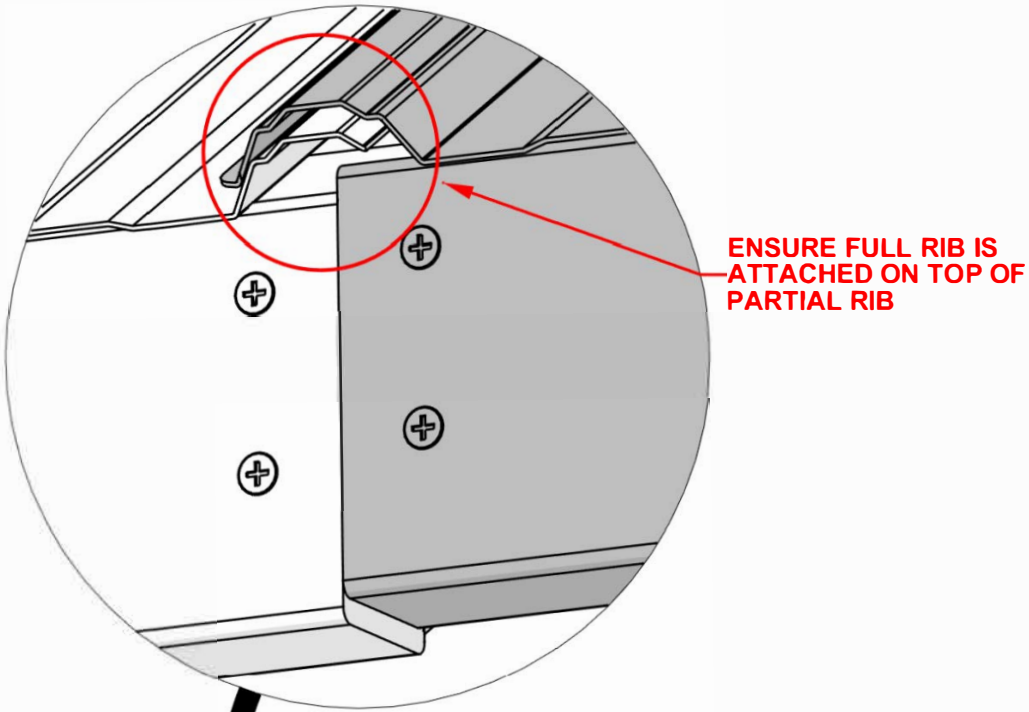
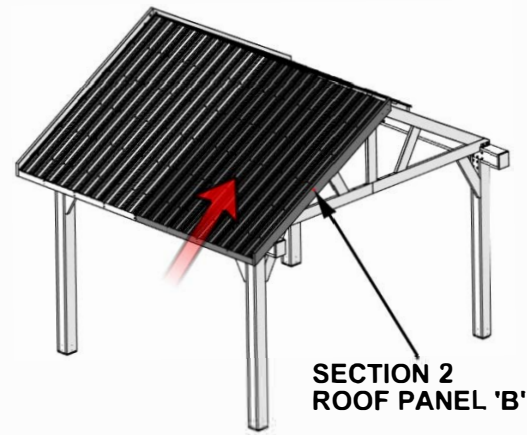

STEP 42 - ROOF ASSEMBLY

QTY	PART NUMBER	DESCRIPTION
2	H100195	BOLT WH 5/16x2 3/4 BLK
8	H100198	WASHER LOCK EXT 8x19
6	H100478	WASHER FLAT 8x27 BLK
6	H100479	NUT LOCK 5/16 BLK
6	H100503	BOLT WH 5/16x3 1/2 BLK

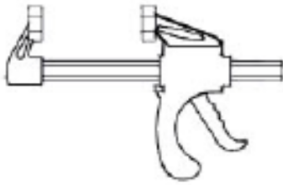

A6P00460 6' QUICK RELEASE CLAMP

REUSE HARDWARE SET ASIDE WHEN PANELS WERE SEPERATED

- HAND TIGHTEN HARDWARE.

- ADDITIONAL PEOPLE ARE HELPFUL FOR THIS STEP.
- SLIDE ROOF PANEL ALONG GABLE BEAM.
- ALIGN HOLES AND ATTACH HARDWARE AS SHOWN BELOW.
- USE A6P00460 QUICK RELEASE CLAMPS IF NEEDED.

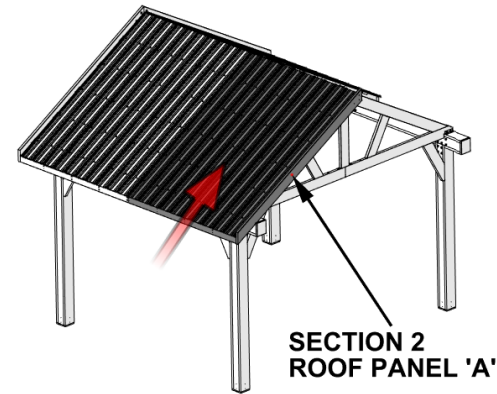

SECTION 2 ROOF PANEL 'A'

IMPORTANT TO ATTACH HARDWARE ALONG RIDGE PEAK FIRST, FASTEN ROOF PANELS TOGETHER AFTER

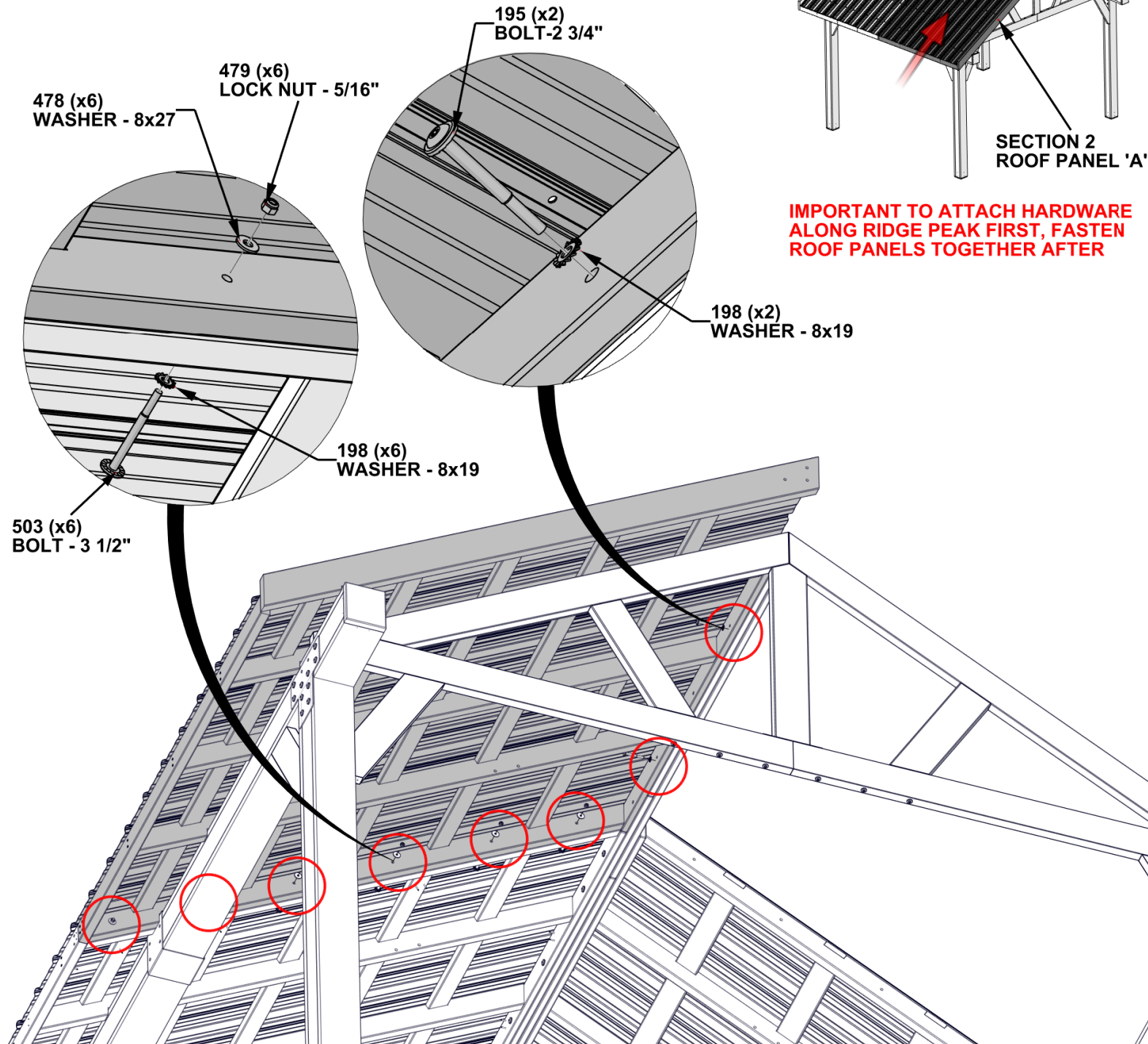

STEP 43 - ROOF ASSEMBLY

CRITICAL:

- IT IS IMPORTANT THAT THE PANELS ARE INSTALLED AS SHOWN.
- PARTIAL RIB MUST BE INSTALLED UNDER FULL RIB.
- FAILURE TO DO SO WILL RESULT IN LEAKING.

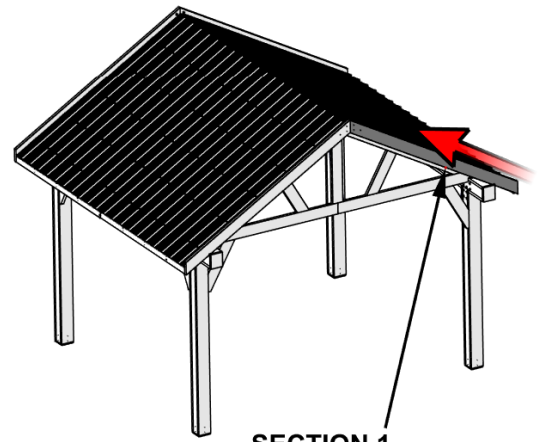

SECTION 1
ROOF ASSEMBLY 'A'

ENSURE FULL RIB IS
ATTACHED ON TOP OF
PARTIAL RIB

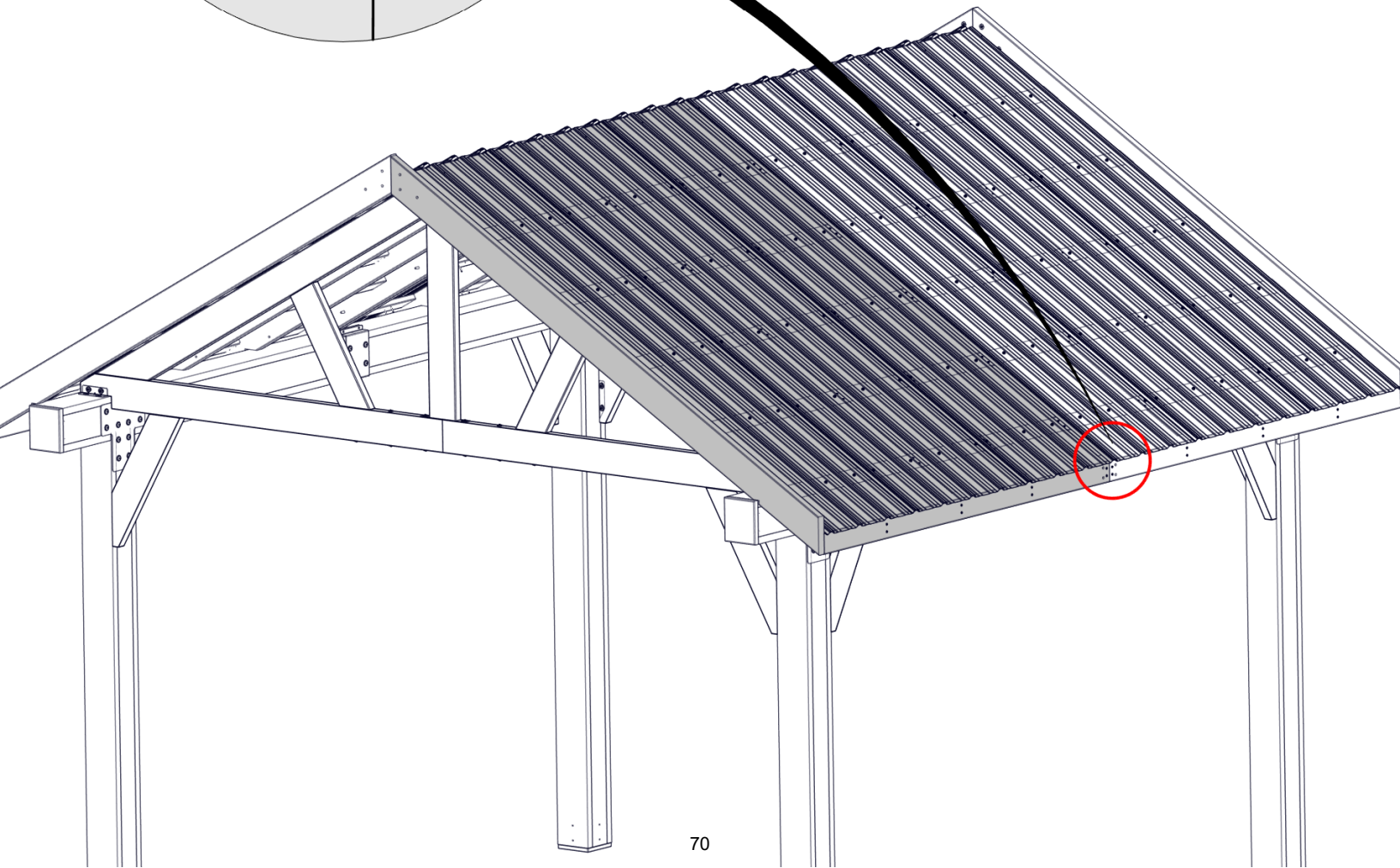
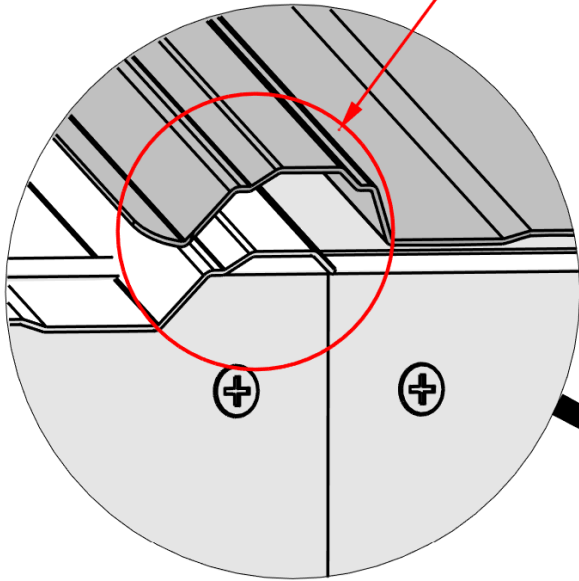

STEP 44 - ROOF ASSEMBLY

QTY	PART NUMBER	DESCRIPTION
9	H100198	WASHER LOCK EXT 8x19
6	H100478	WASHER FLAT 8x27 BLK
9	H100479	NUT LOCK 5/16 BLK
6	H100503	BOLT WH 5/16x3 1/2 BLK
3	H100534	BOLT WH 5/16x4 1/2 BLK
3	H100630	WASHER FLAT 8x19 BLK

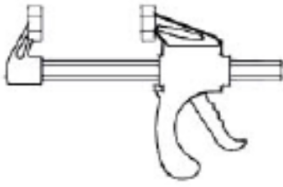

A6P00460 6' QUICK RELEASE CLAMP

**REUSE HARDWARE SET
ASIDE WHEN PANELS
WERE SEPERATED**

- HAND TIGHTEN HARDWARE.

- ADDITIONAL PEOPLE ARE HELPFUL FOR THIS STEP.
- SLIDE ROOF PANEL ALONG GABLE BEAM.
- ALIGN HOLES AND ATTACH HARDWARE AS SHOWN BELOW.
- USE A6P00460 QUICK RELEASE CLAMPS IF NEEDED.

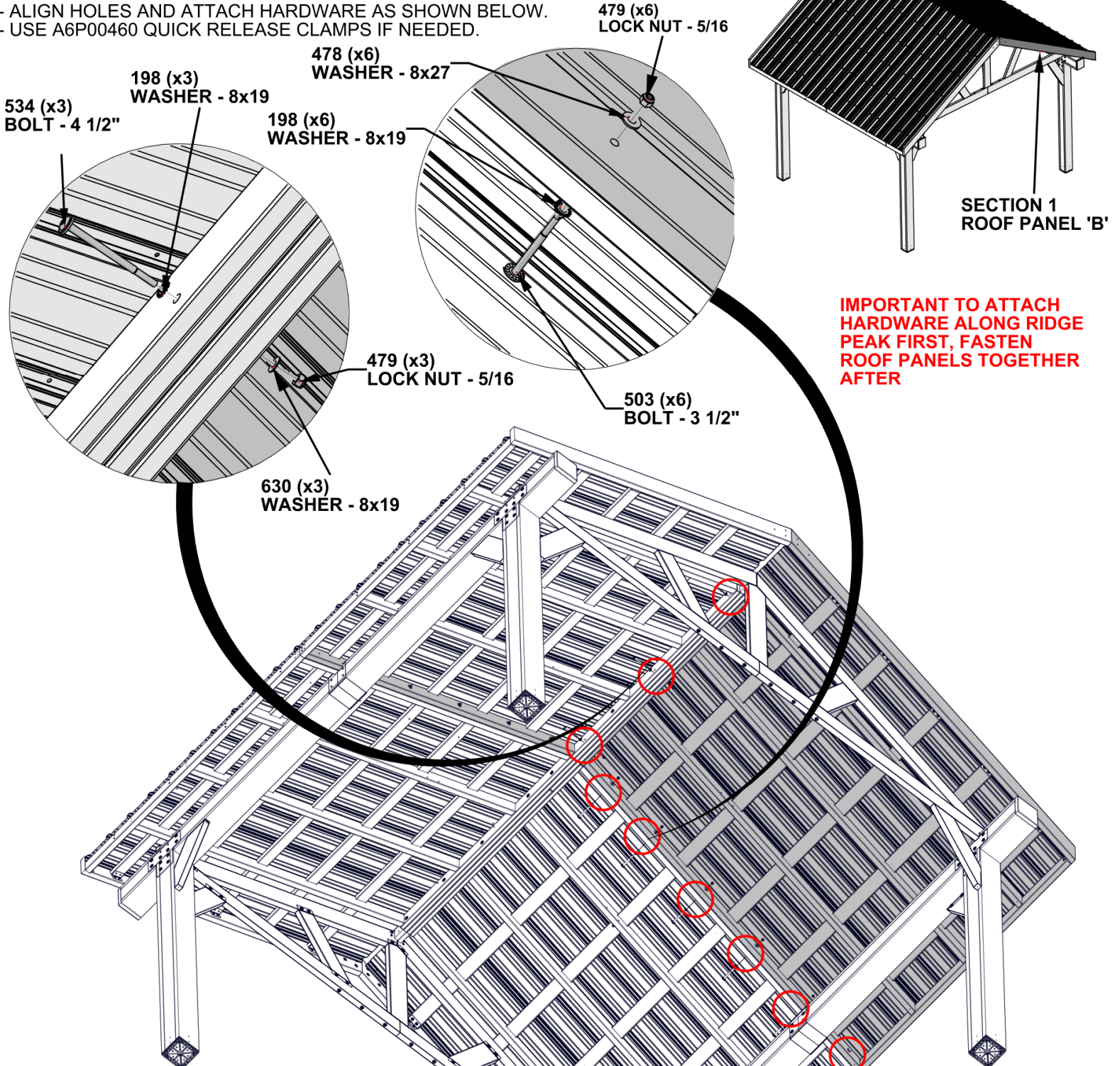

**IMPORTANT TO ATTACH
HARDWARE ALONG RIDGE
PEAK FIRST, FASTEN
ROOF PANELS TOGETHER
AFTER**

STEP 45 - ROOF ASSEMBLY

QTY	PART NUMBER	DESCRIPTION
6	H100459	BOLT WH 5/16x1 1/4 BLK

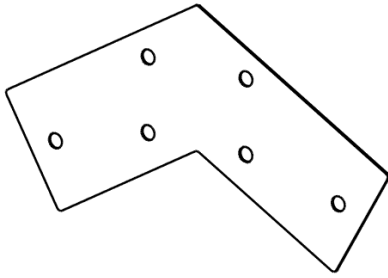

A4M02086 GABLE BRACKET
(x1)

- FASTEN HARDWARE INTO T-NUTS INSTALLED IN D01 AND D02 BOARDS.
- HAND TIGHTEN HARDWARE.
- AFTER ALL HARDWARE HAS BEEN INSTALLED FULLY TIGHTEN ALL HARDWARE.

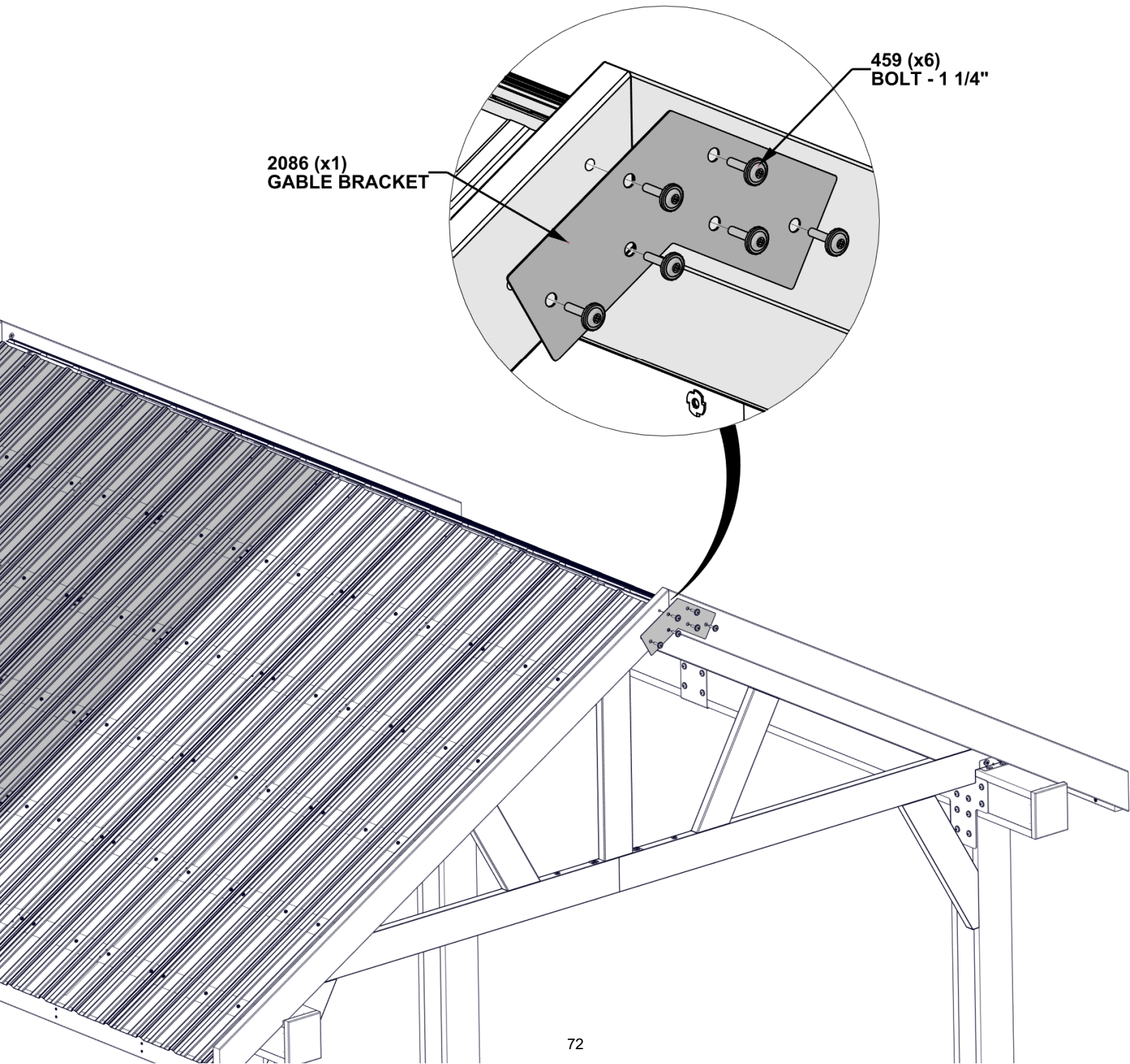

2086 (x1)
GABLE BRACKET

459 (x6)
BOLT - 1 1/4"

STEP 46 - ROOF ASSEMBLY

QTY	PART NUMBER	DESCRIPTION
8	H100205	BOLT WH 5/16x2 1/4 BLK
8	H100478	WASHER FLAT 8x27 BLK
8	H100479	NUT LOCK 5/16 BLK



R01 RAFTER SUPPORT BRACE - A4M04329
(x2) 1 9/16"x4 3/8"x60 1/8" (40x111x1527)

- ALIGN RAFTER SUPPORT BRACE WITH HOLES IN RAFTER BEAMS AS SHOWN.

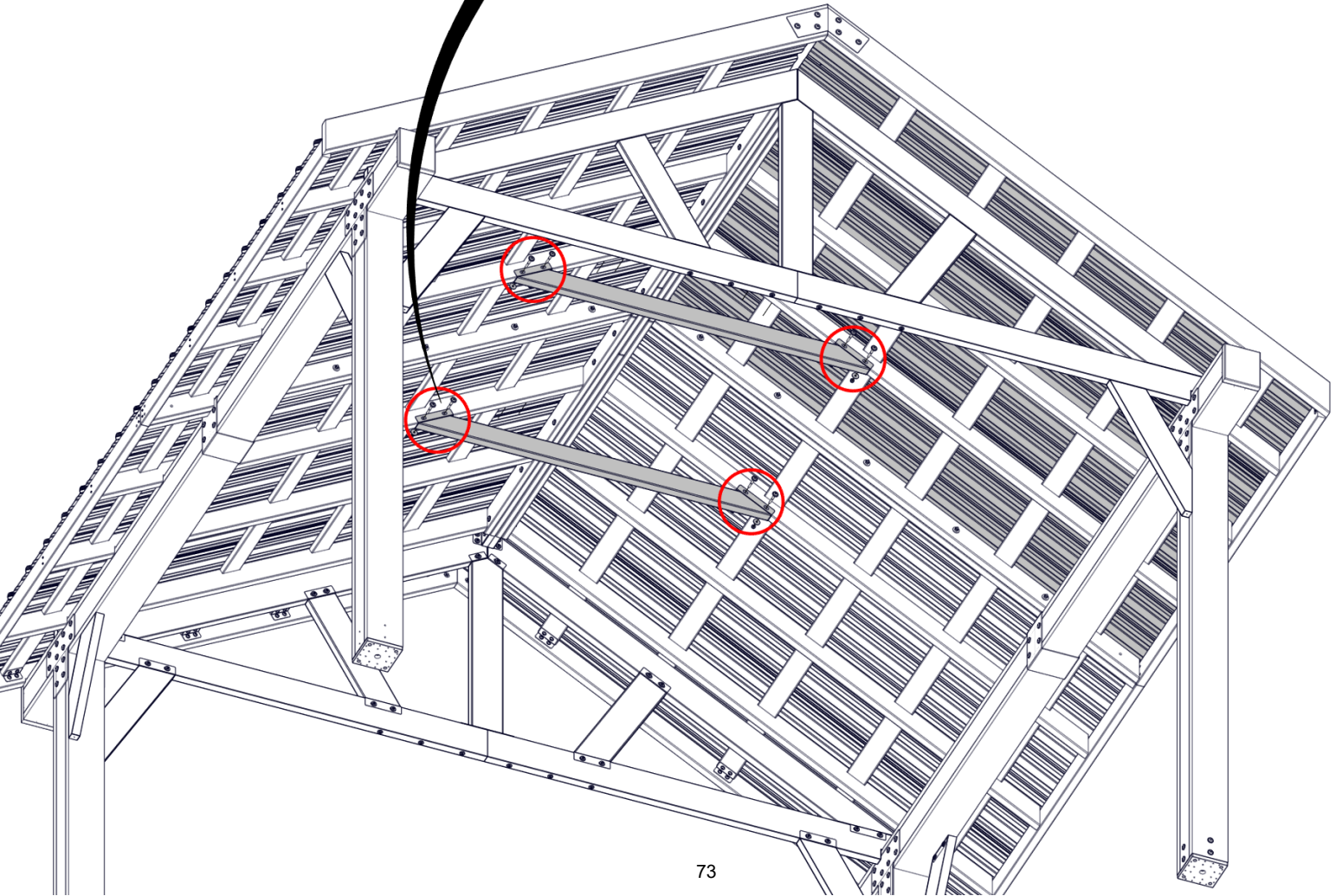
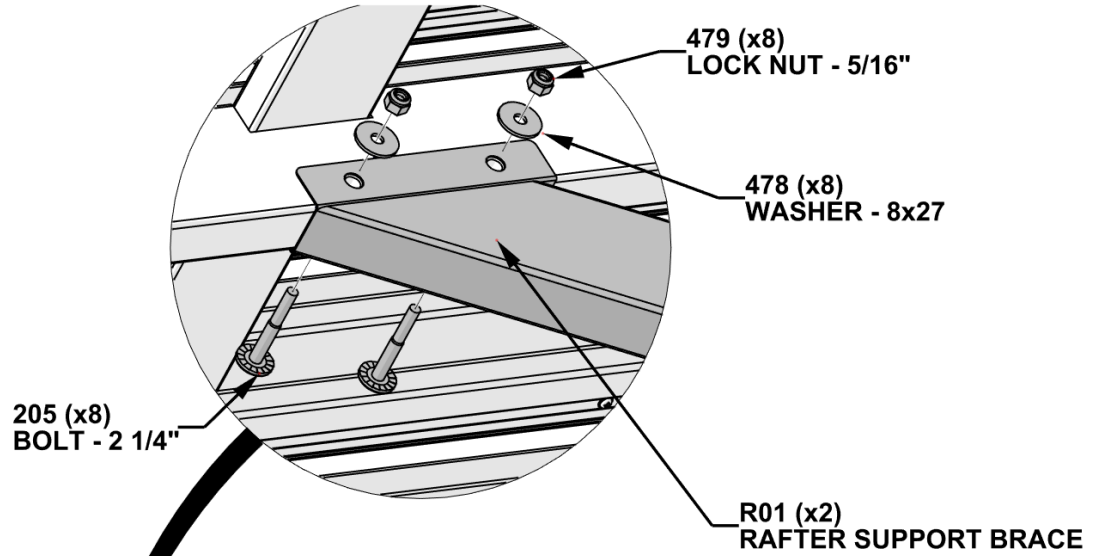

STEP 47 - ROOF ASSEMBLY

QTY	PART NUMBER	DESCRIPTION
8	H100567	BOLT WH 1/4x2 1/4 BLK
8	H100630	WASHER FLAT 8x19 BLK
8	H100653	NUT LOCK 1/4 BLK
24	H100823	SCREW PWH 8x1 1/2 BLK

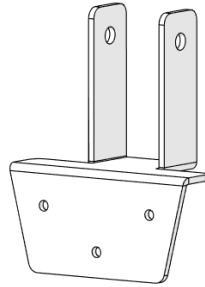

A4M05398 RAFTER CLIP
(x8)

- ALIGN RAFTER CLIP WITH HOLES IN RAFTERS.
- COMPLETE ON BOTH SIDES.

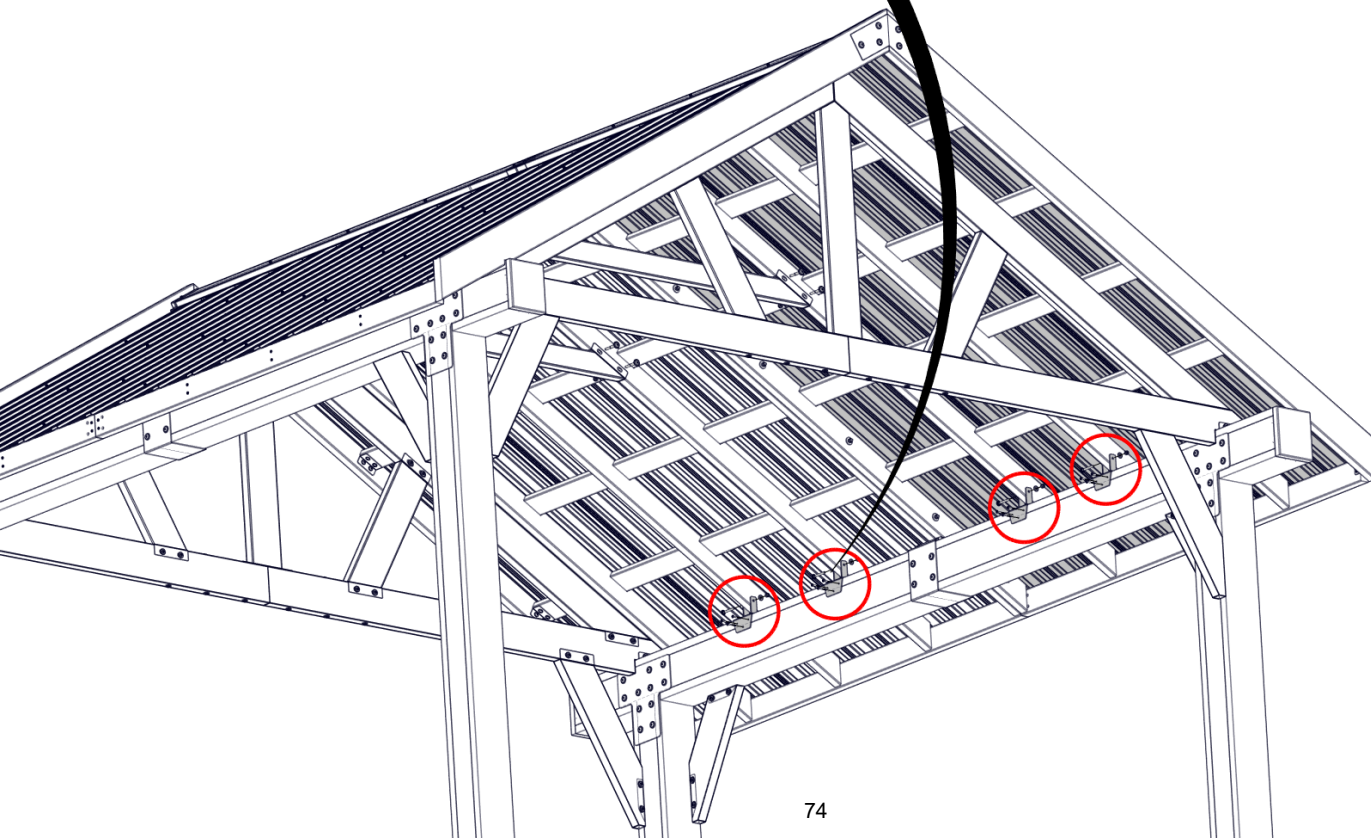
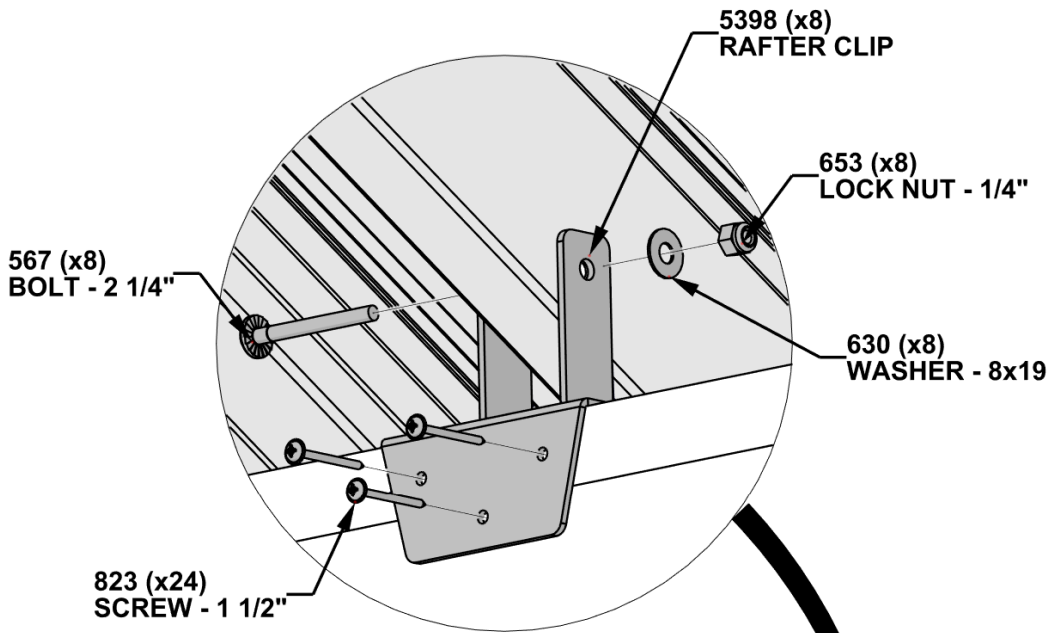

STEP 48 - ROOF ASSEMBLY

QTY	PART NUMBER	DESCRIPTION
20	H101116	SCREW SELF TAPPING 1/4x1 BLK

A4M04325 ROOF END TRIM
(x2)

A4M04326 ROOF END TRIM
(x2)

- REMOVE PROTECTIVE BLUE FILM.
- GLOVES SHOULD BE WORN WHEN HANDLING ROOF PANELS: EDGES ARE SHARP.
- ALIGN 1116 HARDWARE IN LINE WITH HARDWARE FROM ROOF SHEETING.

ALIGN HARDWARE WITH
SHEET METAL SCREWS IN
ROOF ASSEMBLY

1116 (x20)
SCREW - 1"

CENTER HARDWARE ALONG
ROOF END TRIM AS SHOWN

4325 (x1)
ROOF
END TRIM

4326 (x1)
ROOF
END TRIM

4325 (x1)
ROOF
END TRIM

4326 (x1)
ROOF
END TRIM

STEP 49A - ROOF ASSEMBLY

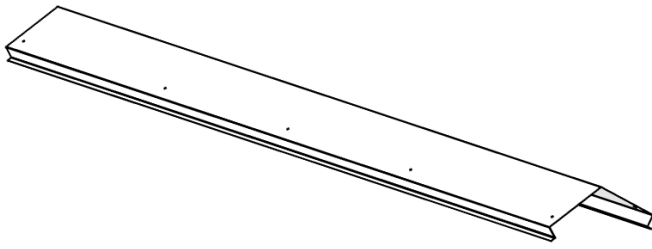

A4M04327 RIDGE CAP
(x2)

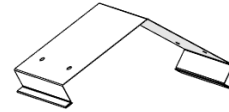

A4M04328 RIDGE CAP SPLICE
(x1)

- REMOVE PROTECTIVE BLUE FILM.
- GLOVES SHOULD BE WORN WHEN HANDLING ROOF PANELS: EDGES ARE SHARP.
- SLIDE EACH RIDGE CAP INTO THE RIDGE CAP SLICE UNTIL CENTERED.

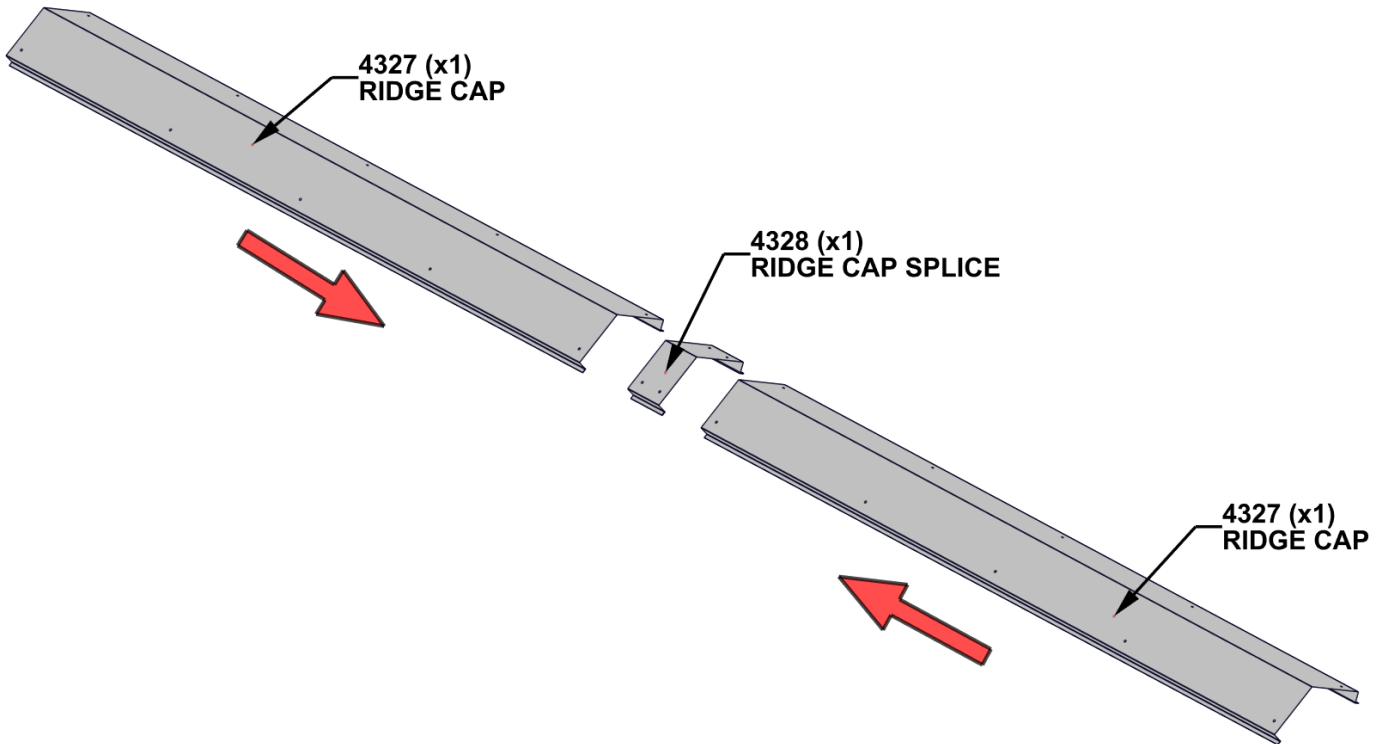

STEP 49B - ROOF ASSEMBLY

QTY	PART NUMBER	DESCRIPTION
20	H101117	SCREW WOODGRIP 10-16x3/4" BLK

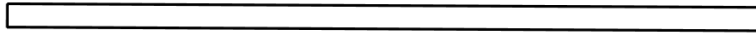

J02 RIDGE CAP STIFFENER - W4L21177
(x2) 15/16"X2 3/8"X62 7/8" (24x60x1597)

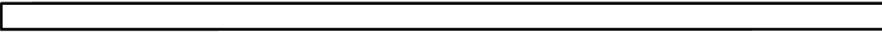

J03 RIDGE CAP STIFFENER - W4L21180
(x2) 15/16"X2 3/8"X82 5/8" (24x60x2100)

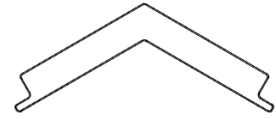

A6P00693 RIDGE CAP PROTECTOR
(x2)

- REMOVE SPACERS FROM RIDGE CAP PROTECTORS BEFORE INSTALLING.
- ALIGN THE HOLES ON EACH RIDGE CAP TO THE HOLES IN THE RIDGE CAP SPLICE BEFORE INSERTING.
- **FINAL ASSEMBLED LENGTH - 12'-1 3/4" [3702mm]**

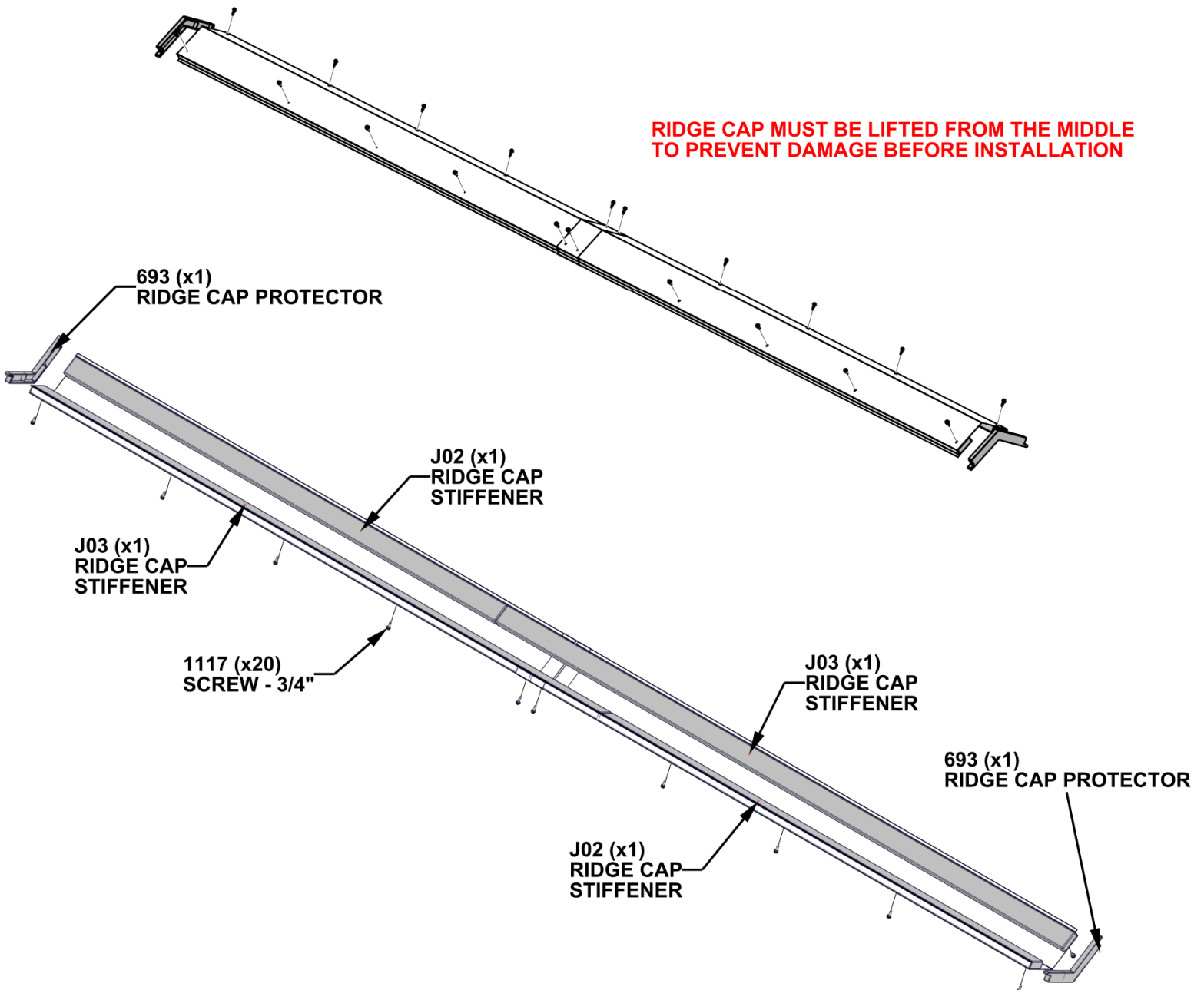

STEP 49C - ROOF ASSEMBLY

QTY	PART NUMBER	DESCRIPTION
16	H100392	SCREW PWH 8x3/4 BLK

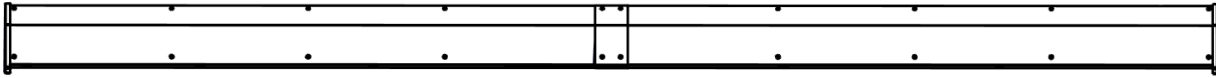

RIDGE CAP ASSEMBLY - FROM PREVIOUS STEP

DO NOT CLIMB ON ROOF TO INSTALL. ROOF CAP HAS BEEN DESIGNED TO INSTALL WITH THE USE OF A LADDER.

- FOR PROPER INSTALLATION, USE AN ADULT HELPER TO KEEP DOWNWARD PRESSURE ON THE RIDGE CAP WHILE SCREWING IN SCREWS.

CENTER RIDGE CAP WITH APPROXIMATELY 1/8" [3mm] GAP ON EITHER SIDE.

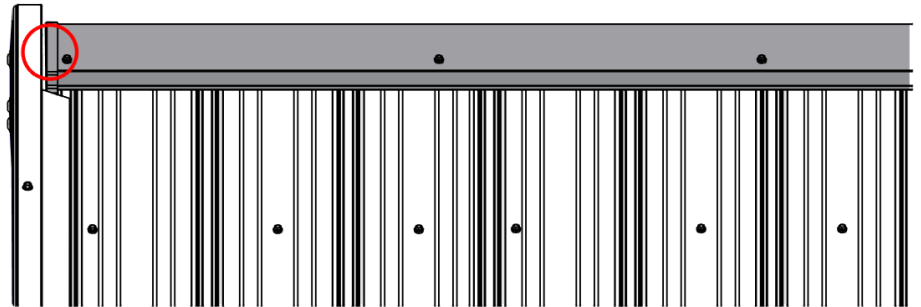

RIDGE CAP ASSEMBLY

SLIDE RIDGE CAP ASSEMBLY ACROSS THE RIDGE UNTIL BOTH ENDS SIT INSIDE RAFTERS AS SHOWN

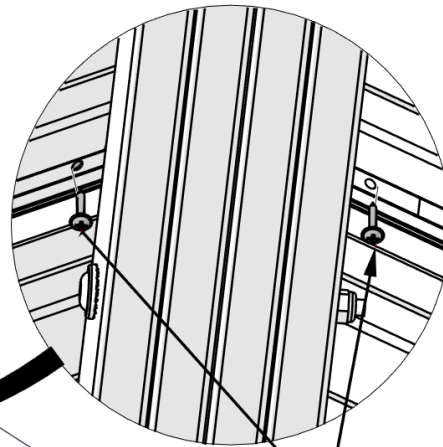
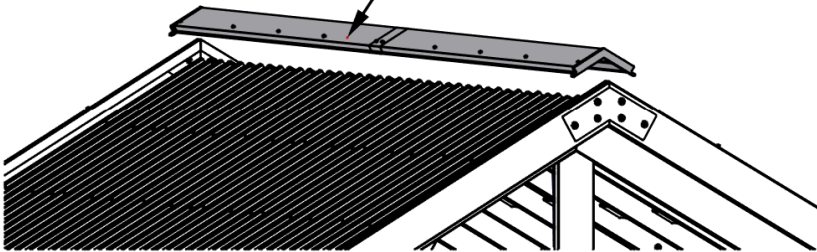

392 (x16)
SCREW - 3/4"

INSTALL SCREWS THROUGH PILOT HOLES IN ROOF PANELS INTO RIDGE CAP STIFFENER BOARDS USING THE H101114 RIGHT ANGLE DRILL ADAPTER ATTACHMENT INCLUDED

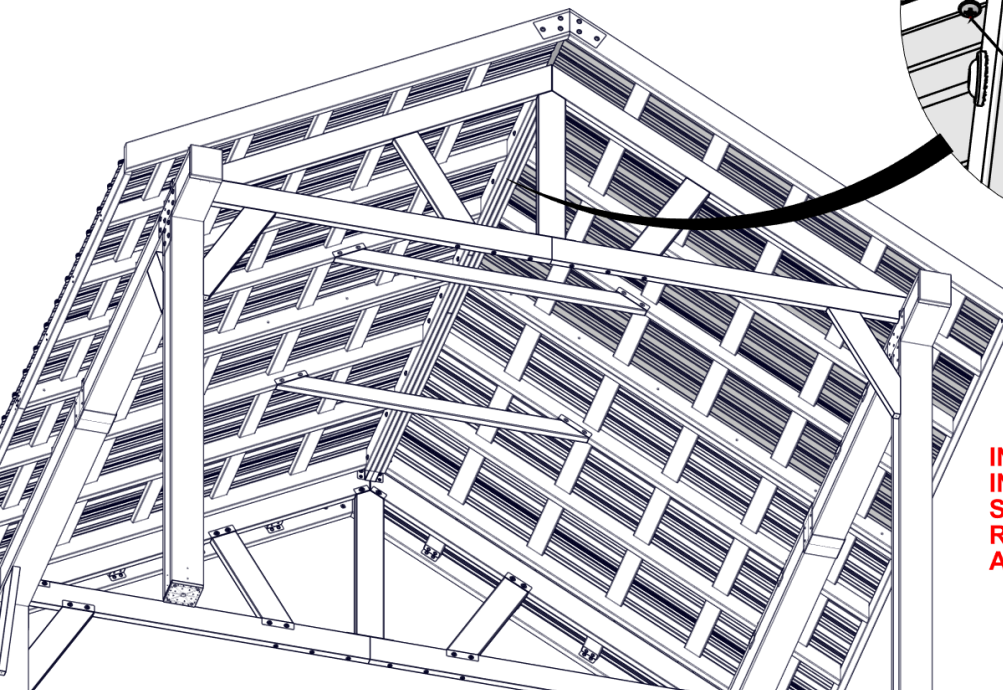

STEP 50 - GAZEBO ASSEMBLY

QTY	PART NUMBER	DESCRIPTION
4	H100391	SCREW PFH 8x2 BLK

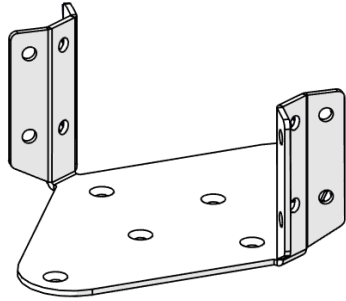

A4M02501 FAN MOUNT BRACKET
(x1)

- BEFORE MOUNTING, ATTACH YOUR ELECTRICAL BOX (PROVIDED SEPERATELY) USING THE PROVIDED HOLES IN FAN MOUNT BRACKET.
- PLACE FAN MOUNT BRACKET ON RIDGE BEAMS AND MOVE TO DESIRED FAN LOCATION.
- ROTATED BRACKET UNTIL MOUNTING FLANGES ALIGN BEST WITH RIDGE BEAMS.
- USE AN 1/8" [3mm] DRILL BIT AND DRILL PILOT HOLES AND ATTACH AS SHOWN.
- IF BRACKET WILL NOT FIT OVER THE RIDGE BEAM, SLIGHTLY FLEX OUT BRACKET EARS TO FIT.

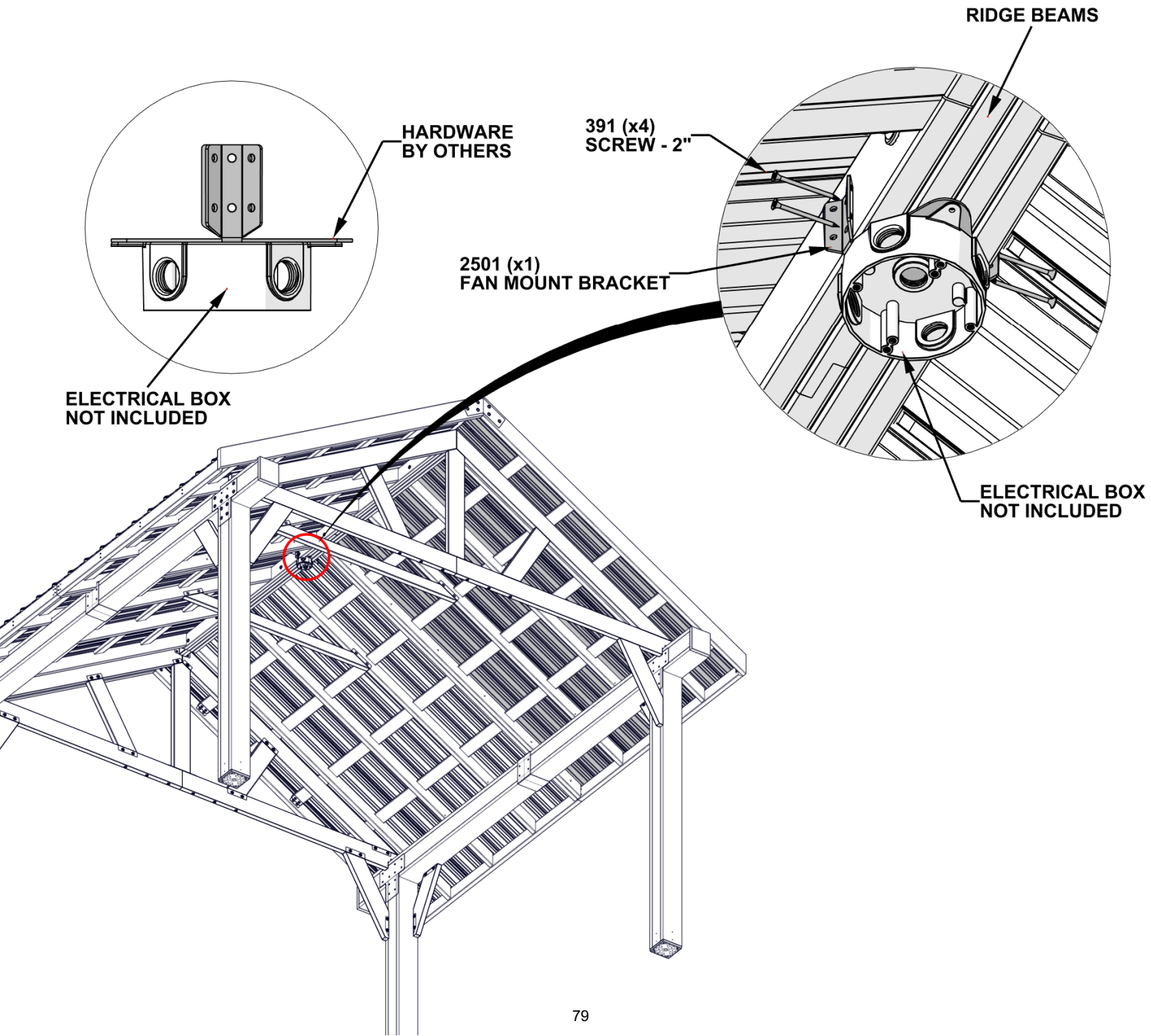

STEP 51 - GAZEBO ASSEMBLY

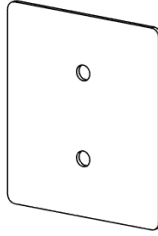
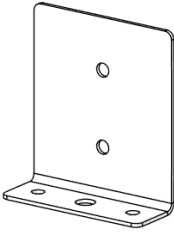

QTY	PART NUMBER	DESCRIPTION
32	H100471	LAG SCREW WH 5/16x1 1/2 BLK

A4M00977 POST ANCHORING PLATE WITH FLANGE
(x8)

A4M00978 POST PLATE
(x8)

- ALIGN POST PLATES WITH PILOT HOLES IN POSTS.

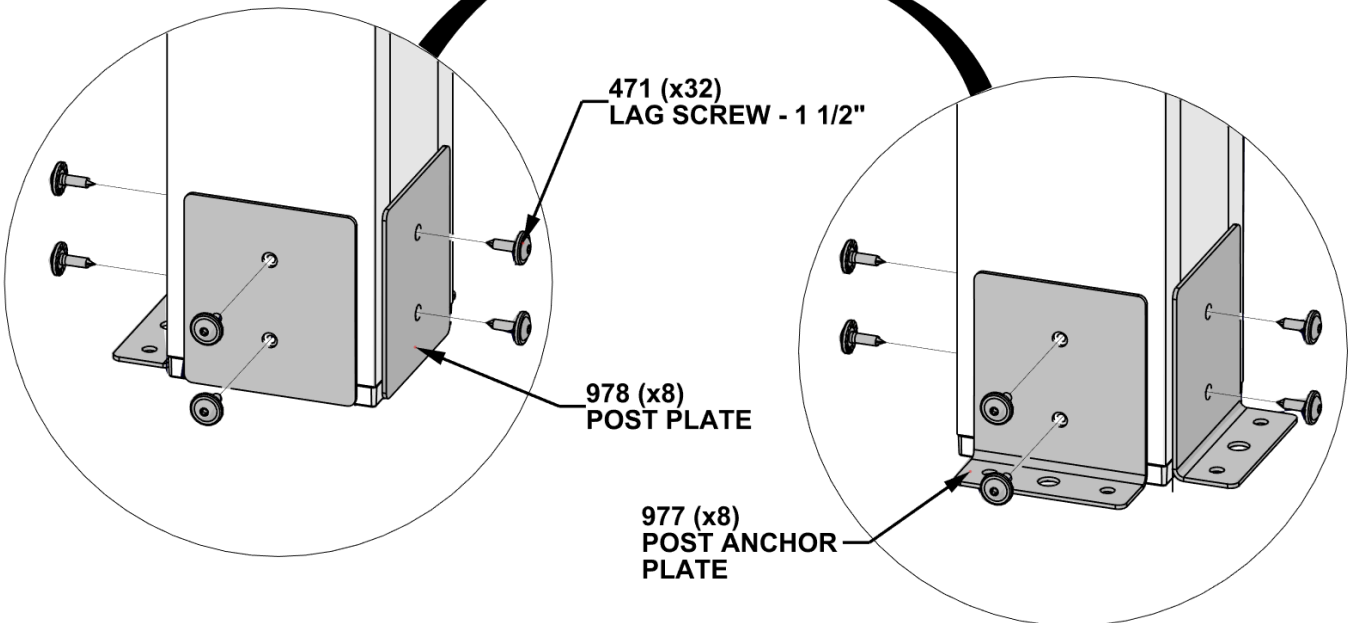
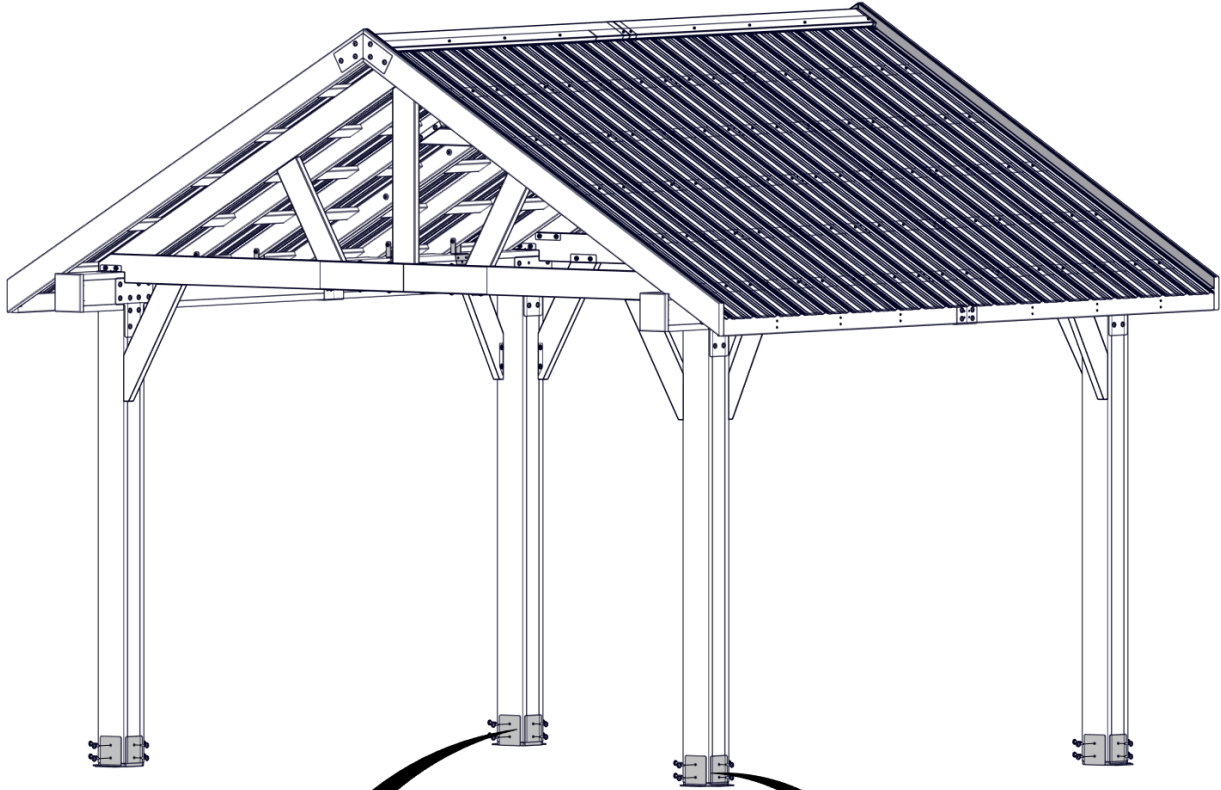

STEP 52 - GAZEBO ASSEMBLY

QTY	PART NUMBER	DESCRIPTION
8	H100407	BOLT WH 5/16x1 1/2 BLK

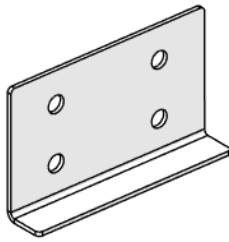

A4M01560 OUTSIDE TIE BRACKET
(x2)

- ALIGN OUTSIDE TIE BRACKET WITH PILOT HOLES IN TRIM BOARDS ON BOTH SIDES.
- NOTE ORIENTATION OF 560 OUTSIDE TIE BRACKET.
- COMPLETE ON BOTH SIDES.

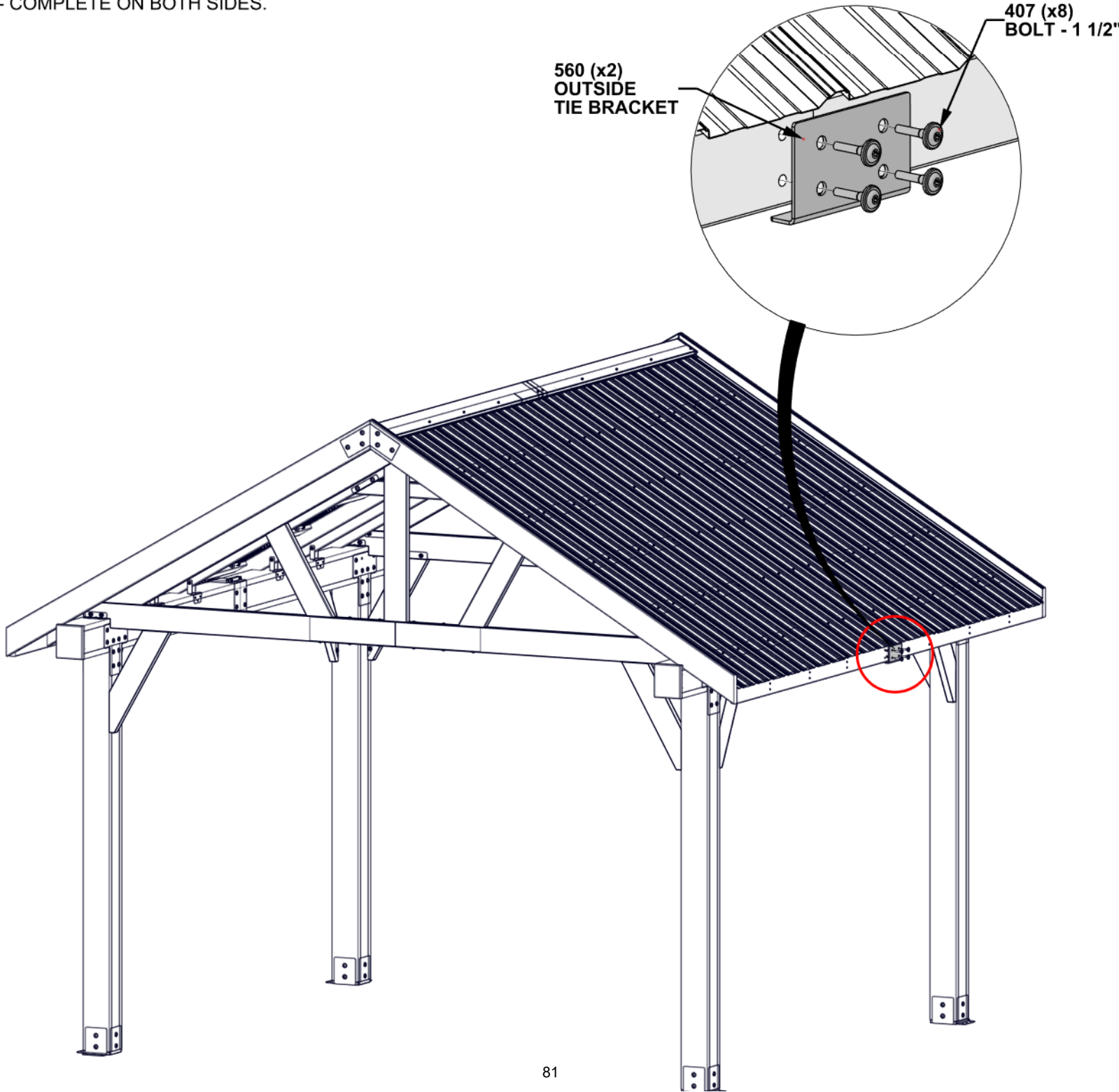

STEP 53 - GAZEBO ASSEMBLY

QTY	PART NUMBER	DESCRIPTION
16	H101165	CONCRETE ANCHOR 3/8x3" BLK

- MANUFACTURER RECOMMENDS INSTALLATION ON CONCRETE SURFACES OR CONCRETE POST PAD AS SHOWN BELOW.
- FOR INSTALLATION ON WOOD DECK, YOU MUST ENSURE THERE IS AMPLE STRUCTURAL SUPPORT UNDER THE DECK.
- HARDWARE NOT INCLUDED FOR DECK ATTACHMENT.

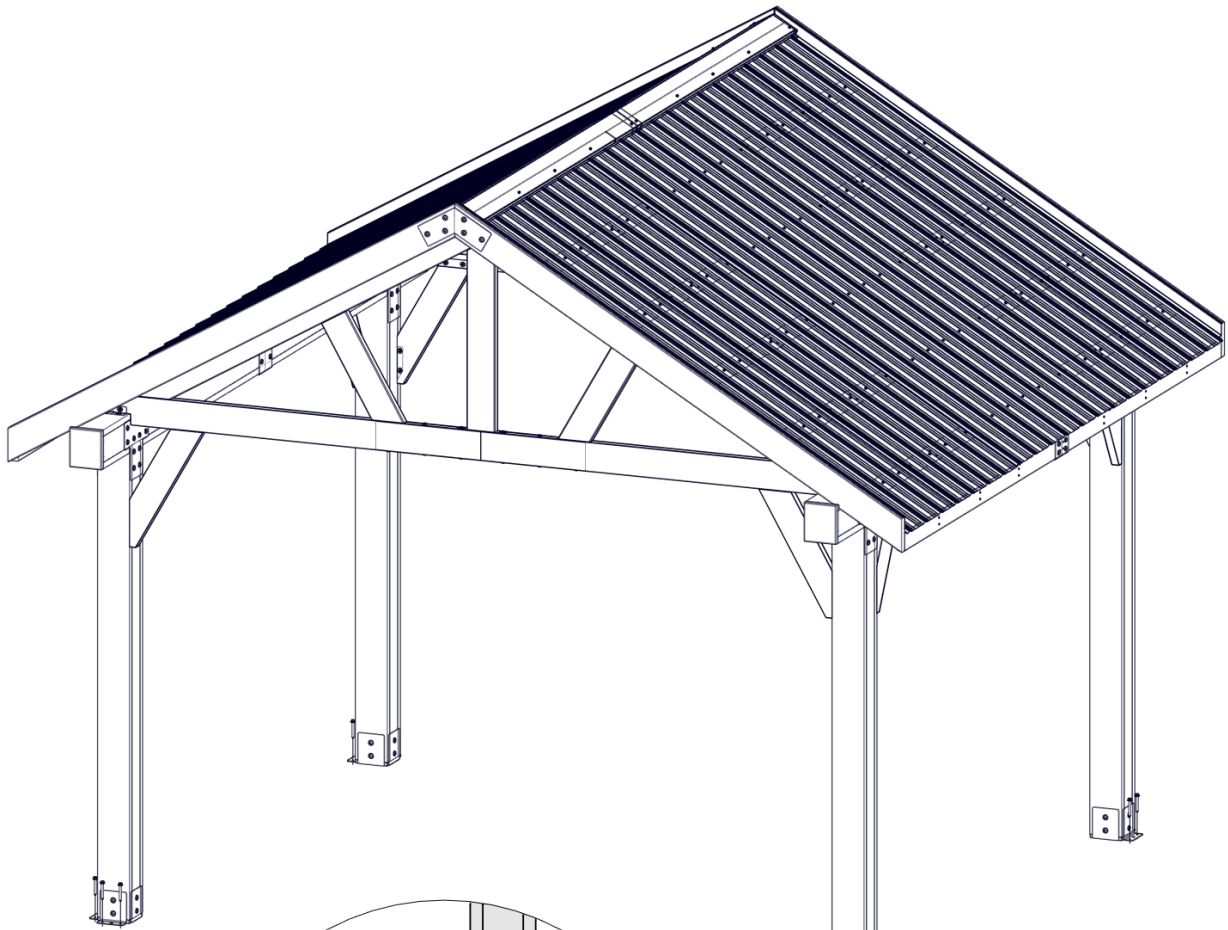

1165 (x16)
CONCRETE ANCHOR-3"

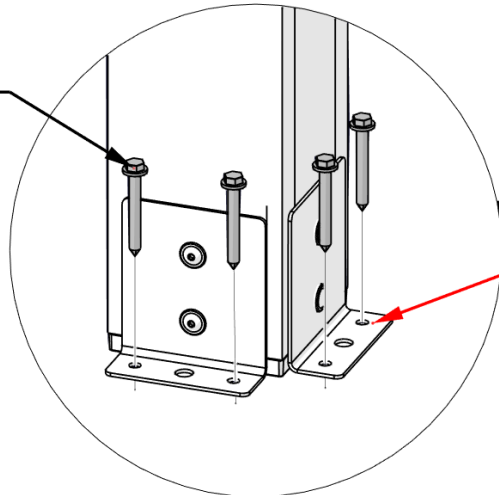

**PRE-DRILL HOLES FOR
CONCRETE ANCHORS USING
A 5/16" [8mm] CONCRETE
DRILL BIT**

STEP 54 - GAZEBO ASSEMBLY

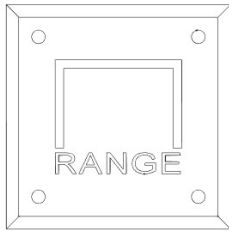

A4M07048 ID TAG RANGE
(x1)

QTY.	PART NUMBER	DESCRIPTION
4	H100202	SCREW PWH 8 X 5/8 BLK

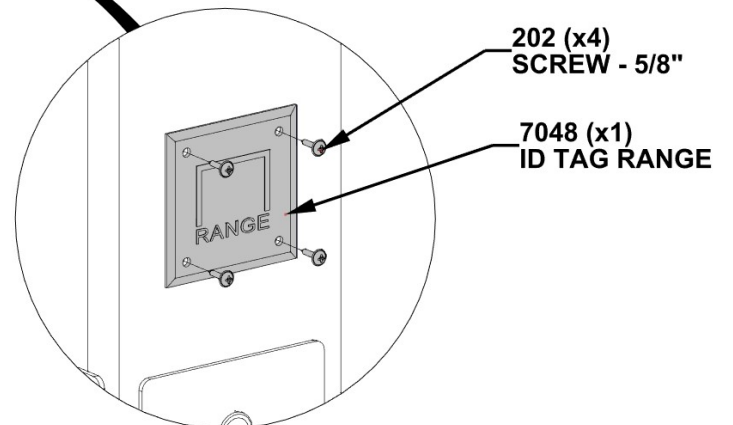
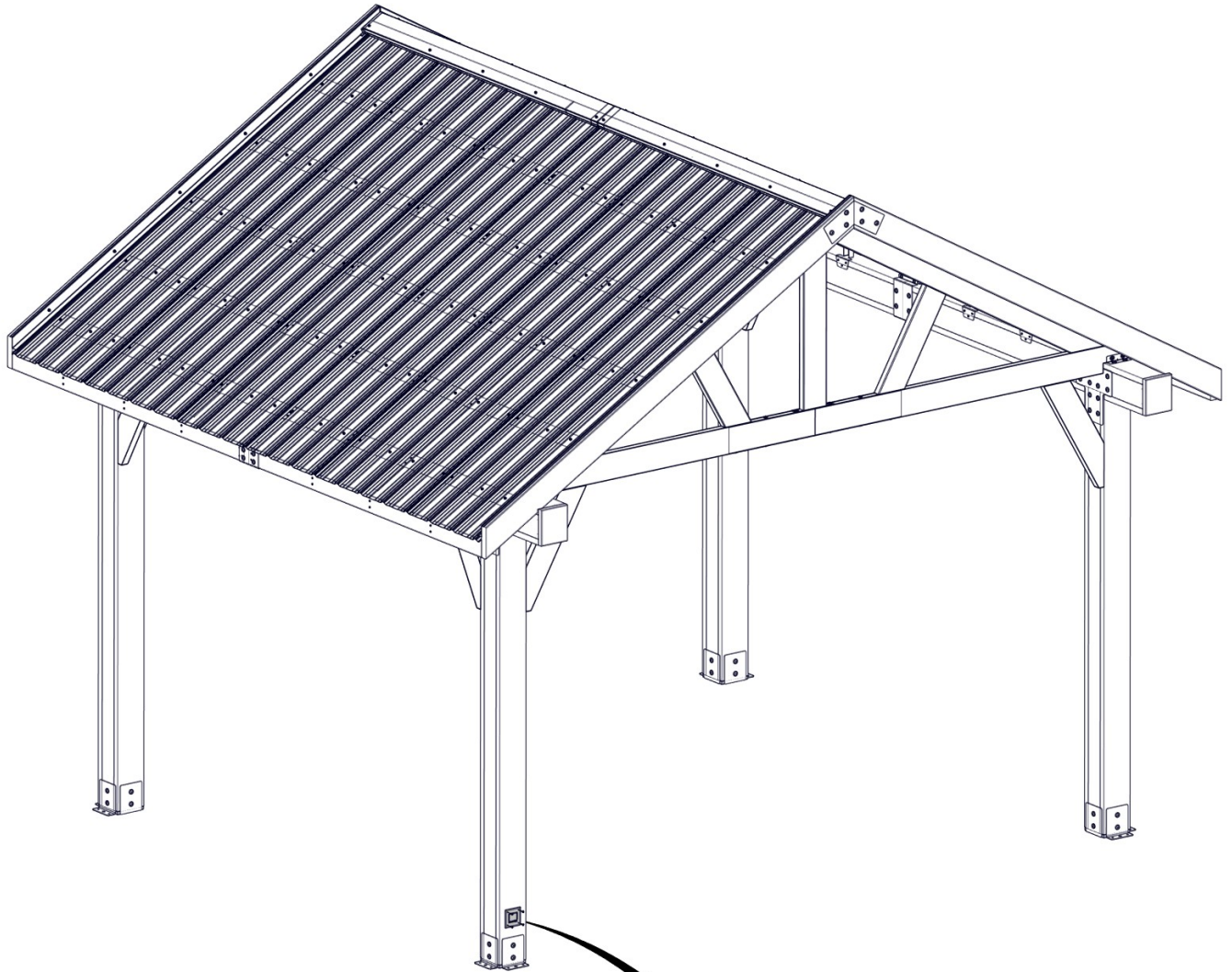

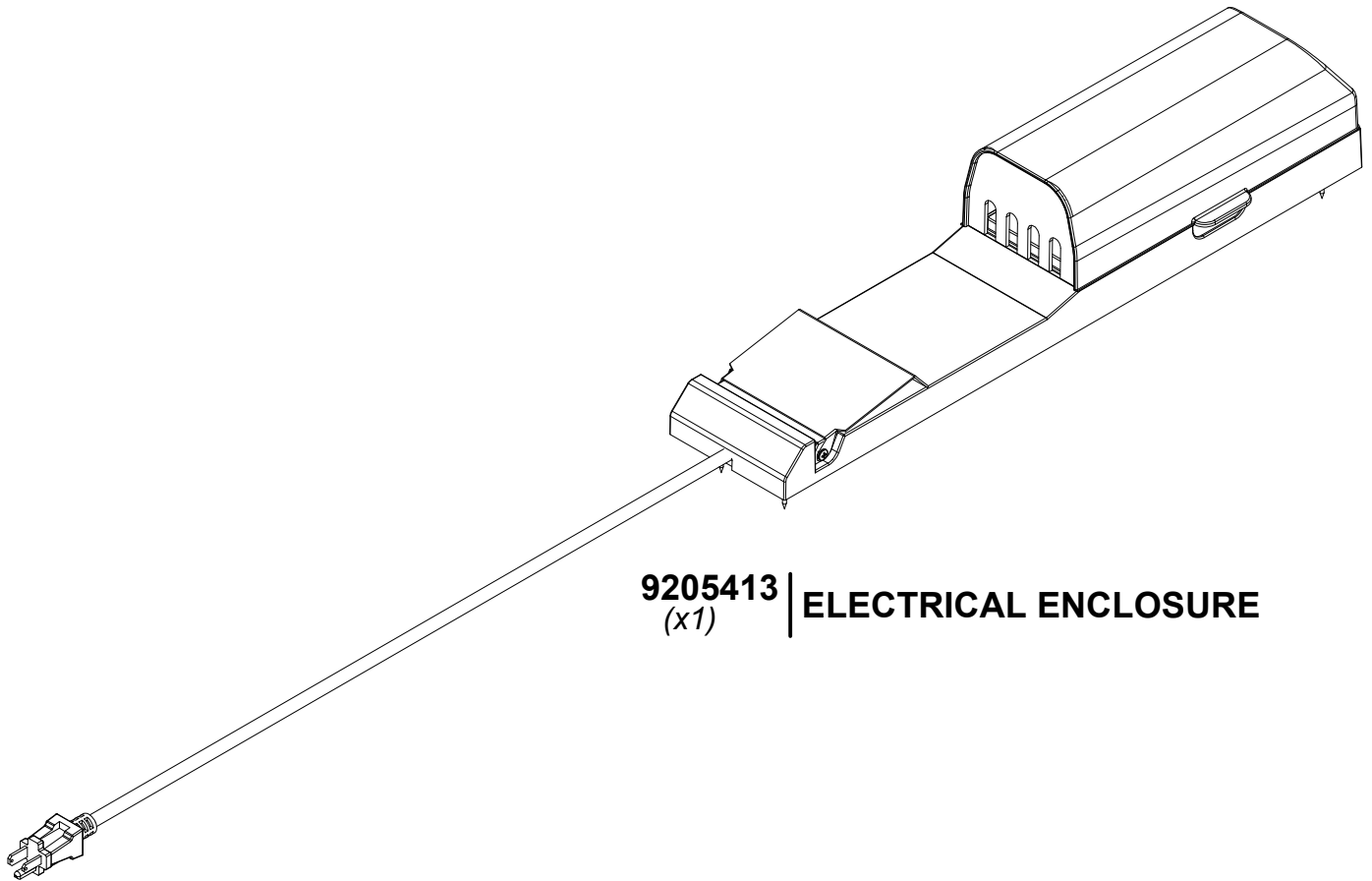

9205413 | **ELECTRICAL ENCLOSURE**
(x1)

FOR POWERPORT INSTALLATION REFER TO ASSEMBLY INSTRUCTIONS THAT COME PACKAGED WITH THE POWERPORT KIT. INSTALL ON ANY POST THAT IS DESIRED. FOLLOW DIRECTIONS FOR PROPER INSTALLATION.