

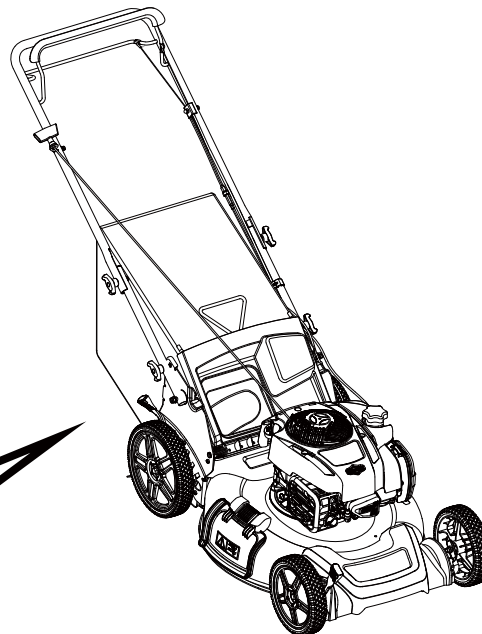

READ AND UNDERSTAND ALL INSTRUCTION, WARNING, AND DANGER LABELS.



Before starting the mower engine, ensure the mower is fully assembled and ready for operation.



**1**

Unfold the lower handle (a) to the operating position.

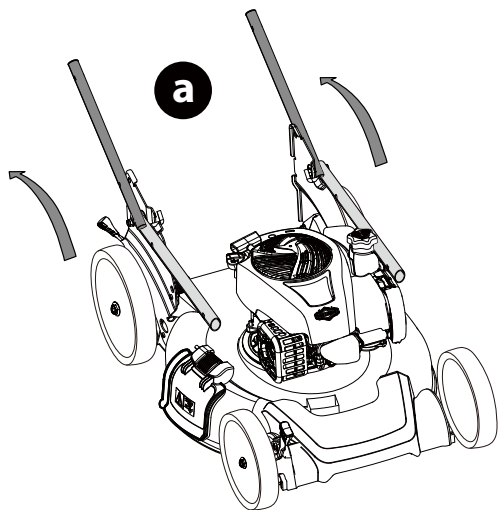

**2**

Fasten the lower handle to the handle bracket by using 1 knob (b) and 1 bolt (c) on each side.

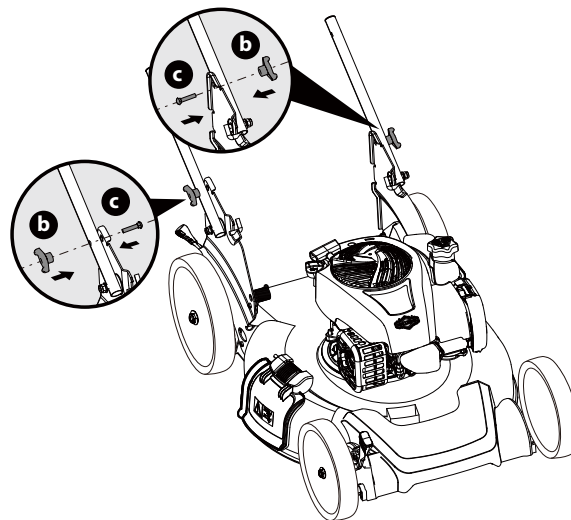

**IMPORTANT: READ OPERATOR'S MANUAL AND ENGINE MANUAL THOROUGHLY AND FOLLOW THE IMPORTANT SAFE OPERATION PRACTICES BEFORE OPERATING.**



Need Hel

[www.CRAFTSMAN.com](http://www.CRAFTSMAN.com)  
or Call 1-888-331-4569



READ AND UNDERSTAND ALL INSTRUCTION, WARNING, AND DANGER LABELS.



3

Unfold the upper handle (d) and attach it to the lower handle by using 1 knob (b) and 1 bolt (c) on each side, make sure the blade control bar (e) is facing upwards.

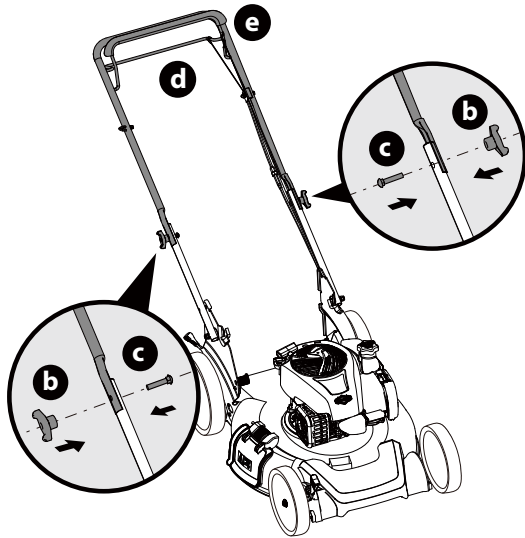

4

The rope guide is attached to the right side of the upper handle.  
a. Hold blade control against upper handle.  
b. Slowly pull starter rope handle from engine and slip starter rope into the rope guide.  
c. Use cord clip to secure blade control cable to lower handle.

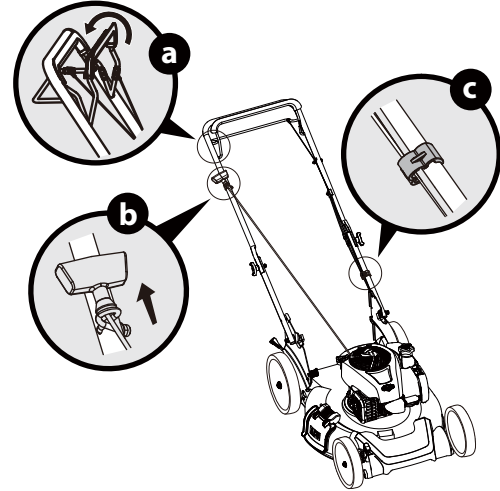

5



Pour the entire contents of the supplied oil bottle into the oil fill. Check the oil level by inserting the dipstick (not threading it) into the oil fill (Refer to the Operator's Manual).

Oil fill located on the left side of most engines

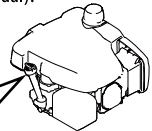

6

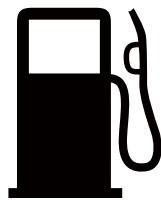

Fill tank with fresh gas to within 1/2-inch of top of tank. Do not overfill. Do not use E85 or fuel containing more than 10% Ethanol.

Fuel fill located on the left side of most engines

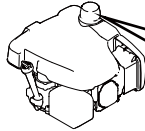

7

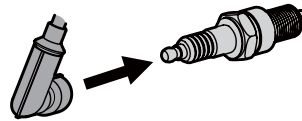

Make sure the spark plug boot is connected to the spark plug before attempting to start.

Spark plug located on the front of most engines

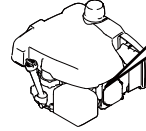

8

When starting a cold engine, press down the primer fully 3-5 times

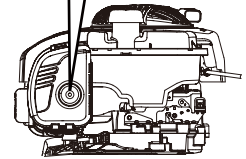

9

### Recoil Start

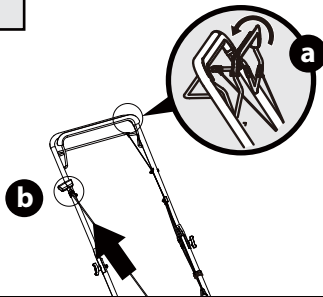

- a. While standing behind the mower, pivot the blade control against the upper handle
- b. Grasp the recoil starter rope handle and pull with quick, full-arm stroke. If the engine does not start with three pulls, repeat the starting procedure from step 8.



**IMPORTANT: READ OPERATOR'S MANUAL AND ENGINE MANUAL THOROUGHLY AND FOLLOW THE IMPORTANT SAFE OPERATION PRACTICES BEFORE OPERATING.**



Need Help?  
[www.CRAFTSMAN.com](http://www.CRAFTSMAN.com)  
or Call 1-888-331-4569

CRAFTSMAN® is a registered trademark of Stanley Black & Decker, Inc., used under license.

© 2026 CRAFTSMAN U.S. Only

CRAFTSMAN.com



LEA Y ENTIENDA TODAS LAS INSTRUCCIONES, ADVERTENCIAS Y ETIQUETAS DE PELIGRO.



Antes de arrancar el motor de la cortadora, asegúrese de que la cortadora esté completamente ensamblada y lista para operar.

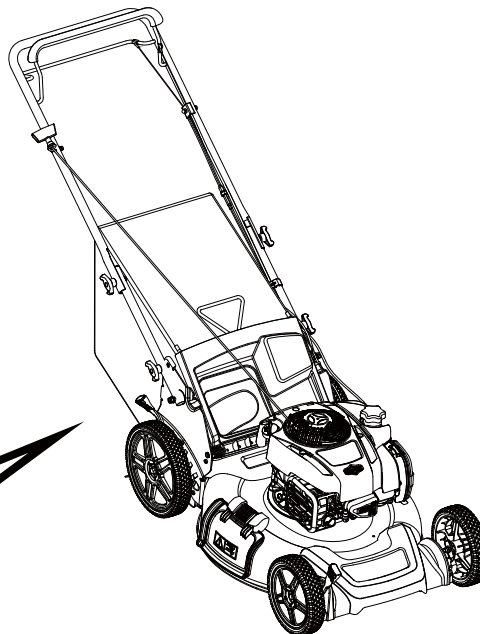

**1**

Despliegue la manija inferior (a) a la posición de operación.

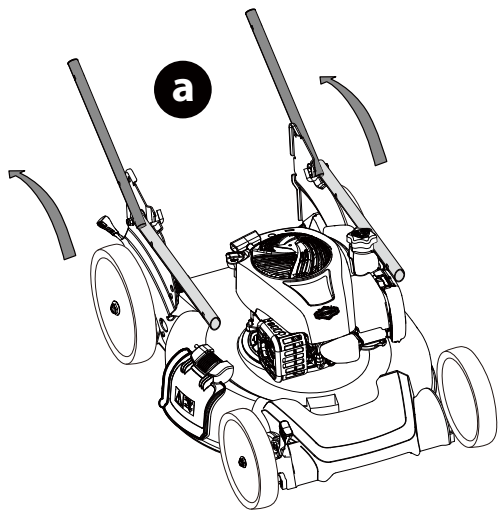

**2**

Fije la manija inferior al soporte de la manija usando 1 perilla (b) y 1 perno (c) en cada lado.

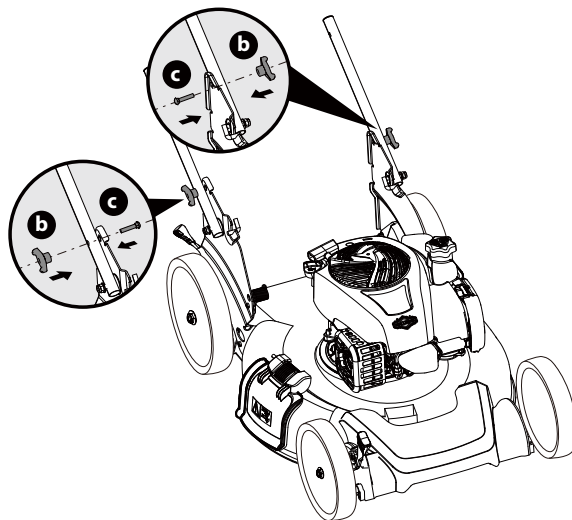

**IMPORTANTE: LEA EL MANUAL DEL OPERADOR Y EL MANUAL DEL MOTOR DETENIDAMENTE Y SIGA LAS PRÁCTICAS IMPORTANTES DE SEGURIDAD ANTES DE OPERAR.**



¿Necesita ayuda?

[www.CRAFTSMAN.com](http://www.CRAFTSMAN.com)

o llame al 1-888-331-4569



LEA Y ENTIENDA TODAS LAS INSTRUCCIONES, ADVERTENCIAS Y ETIQUETAS DE PELIGRO.



**3**

Despliegue la manija superior (d) y conéctela a la manija inferior usando 1 perilla (b) y 1 perno (c) a cada lado, asegúrese de que la barra de control de la cuchilla (e) esté orientada hacia arriba.

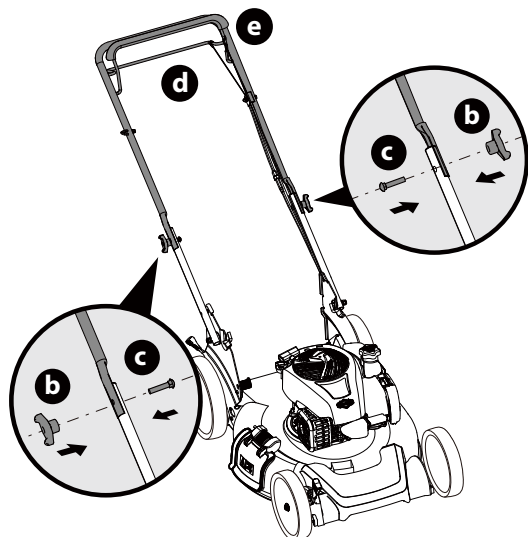

**4**

La guía de cuerda está unida al lado derecho de la manija superior.

- Sostenga el control de la cuchilla contra la manija superior.
- Tire lentamente de la manija de la cuerda de arranque del motor y deslice la cuerda de arranque en la guía de cuerda.
- Utilice el clip de cordón para asegurar el cable de control de la cuchilla a la manija inferior.

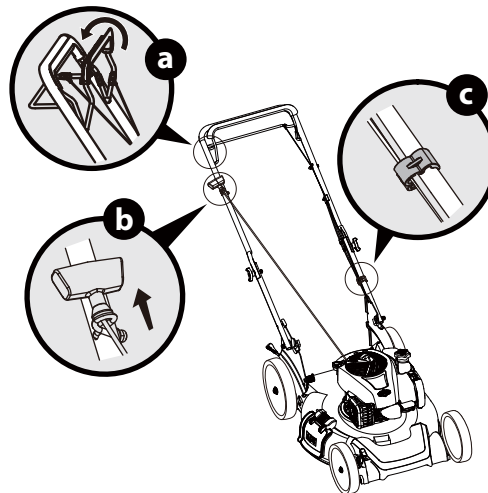

**5**



Vierta todo el contenido de la botella de aceite suministrada en la entrada de aceite. Verifique el nivel de aceite insertando la varilla de medición (sin enroscarla) en la entrada de aceite (consulte el manual del operador).

La entrada de aceite se encuentra en el lado izquierdo de la mayoría de los motores.

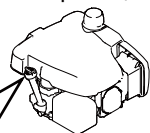

**6**

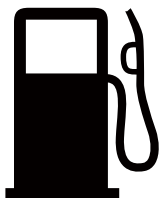

Llene el tanque con gasolina nueva hasta  $\frac{1}{2}$  pulgada de la parte superior del tanque. No lo llene en exceso. No use E85 ni combustible que contenga más del 10% de etanol.

La tapa de combustible se encuentra en el lado izquierdo de la mayoría de los motores

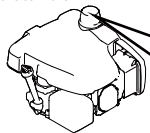

**7**

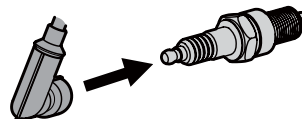

Asegúrese de que la tapa de la bujía esté conectada a la bujía antes de intentar arrancar.

La bujía se encuentra en la parte frontal de la mayoría de los motores

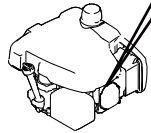

**8**

Al arrancar un motor frío, presione el cebador completamente de 3 a 5 veces.

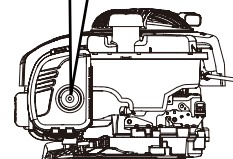

**9**

### Arranque por cuerda

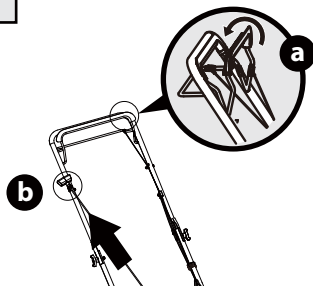

- Estando parado detrás de la cortadora, gire el control de la cuchilla contra la manija superior.
- Tome la manija de la cuerda del arranque por retroceso y tire con un movimiento rápido y completo del brazo. Si el motor no arranca después de 3 jalones, repite el procedimiento de arranque desde el paso 8.



**IMPORTANTE: LEA EL MANUAL DEL OPERADOR Y EL MANUAL DEL MOTOR DETENIDAMENTE Y SIGA LAS PRÁCTICAS IMPORTANTES DE SEGURIDAD ANTES DE OPERAR.**



¿Necesita ayuda?  
www.CRAFTSMAN.com  
o llame al 1-888-331-4569