

# INSTRUCTION

---

## 3PCS SINGLE SOFA & COFFEE TABLE

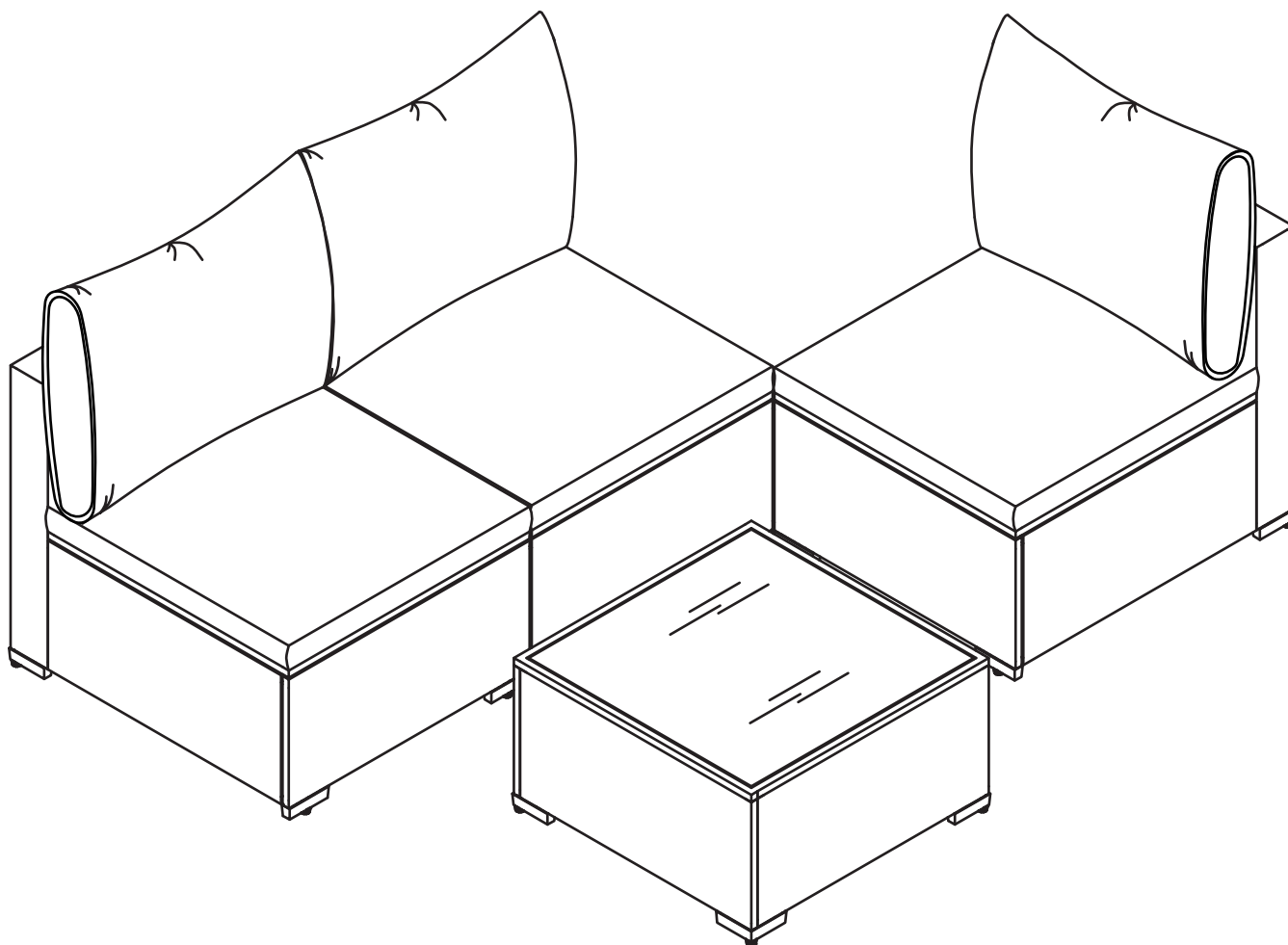

**After-sales mailbox:**  
**[Patiofurniture Serviceteam@outlook.com](mailto:Patiofurniture Serviceteam@outlook.com)**

# NOTICE

---

**EN**

**Please keep these instructions for future reference.**

**Dear Customer**

● Thank you for your purchase. When you receive the product, please make sure that all the parts are intact. If any parts are missing, please contact us promptly to request replacement parts.

● Then follow the entire installation instructions to install.

● Each part is crucial, so please be careful not to lose any. It is recommended to store parts with different lettered identifiers in separate boxes or bags to avoid confusion during installation.

**A** . The outer box is damaged

**B** . The product is damaged / bent / cracked while you open the box

**C** . The parts / accessories / assembly tools are missing

**D** . The instructions are not clear and can not be referred

**E** . The product has functional problems

**F** . Other aspects that you are not satisfied with

**Please feel free to contact us for help, and provide the following information:**

**Platform/Shop name/Order id/Buyer's name/Receiver's address/Problem description/Problem pictures**

([Patiofurniture Serviceteam@outlook.com](mailto:Patiofurniture Serviceteam@outlook.com)) will reply within 24 hours and will do our best to resolve the problem for you.



**Note: First tighten each screw by 60%, and then tighten it according to each part.**



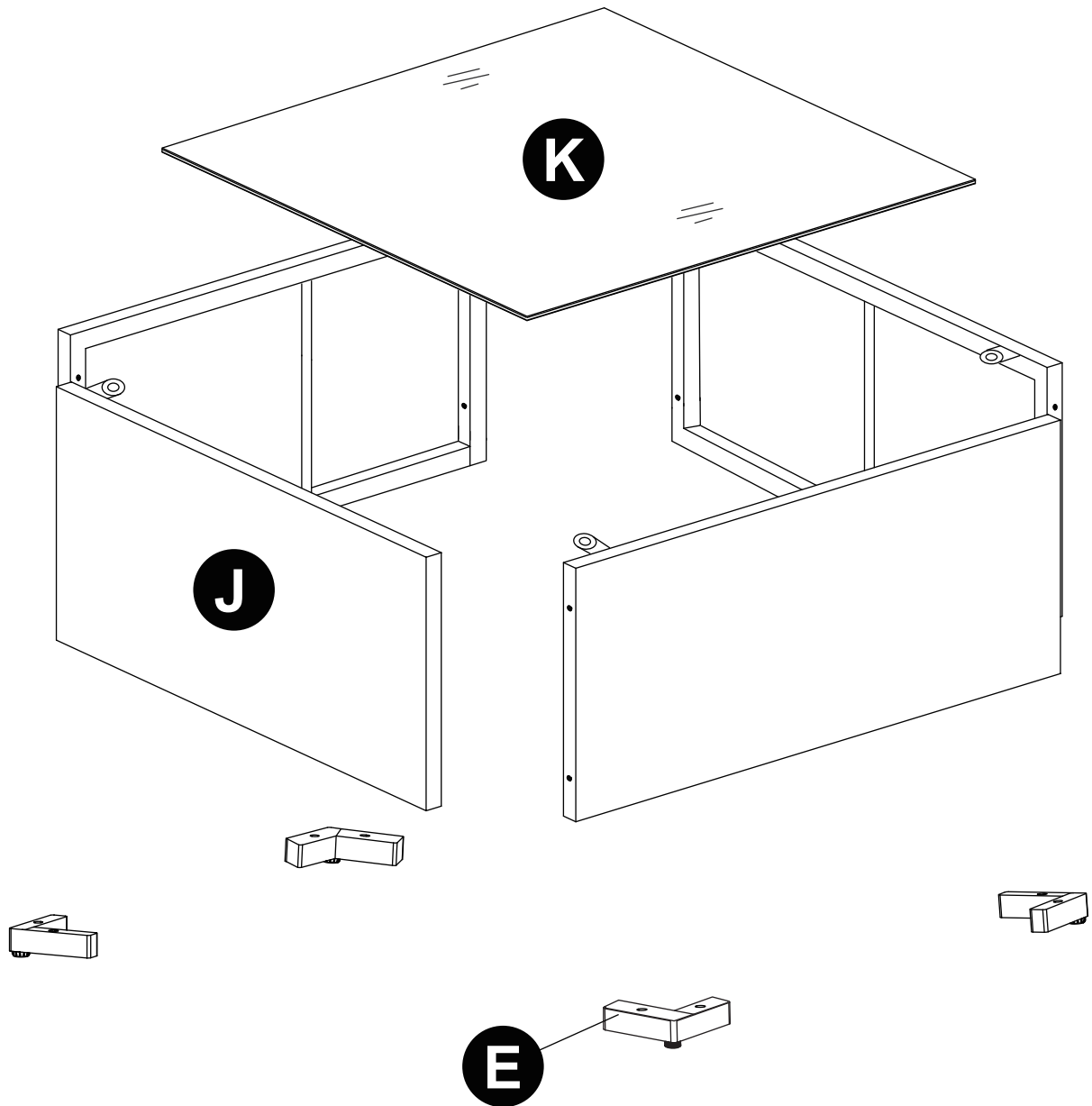



# PART LIST

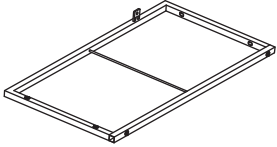
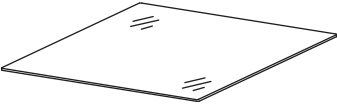

# PART LIST

<p><b>E</b></p> 	<p><b>G</b></p> 	<p><b>J</b></p> 
<p>x4PCS</p>	<p>x4PCS</p>	<p>x4PCS</p>
<p><b>K</b></p> 		
<p>x1PC</p>		



<p><b>M</b></p>  <p>M6x25</p>	<p><b>O</b></p>  <p>M6x32</p>	<p><b>P</b></p>  <p>M6</p>
<p>x8PCS</p>	<p>x8PCS</p>	<p>x8PCS</p>
<p><b>W</b></p>  <p>M6</p>		
<p>x1PC</p>		

# STEP

## 01

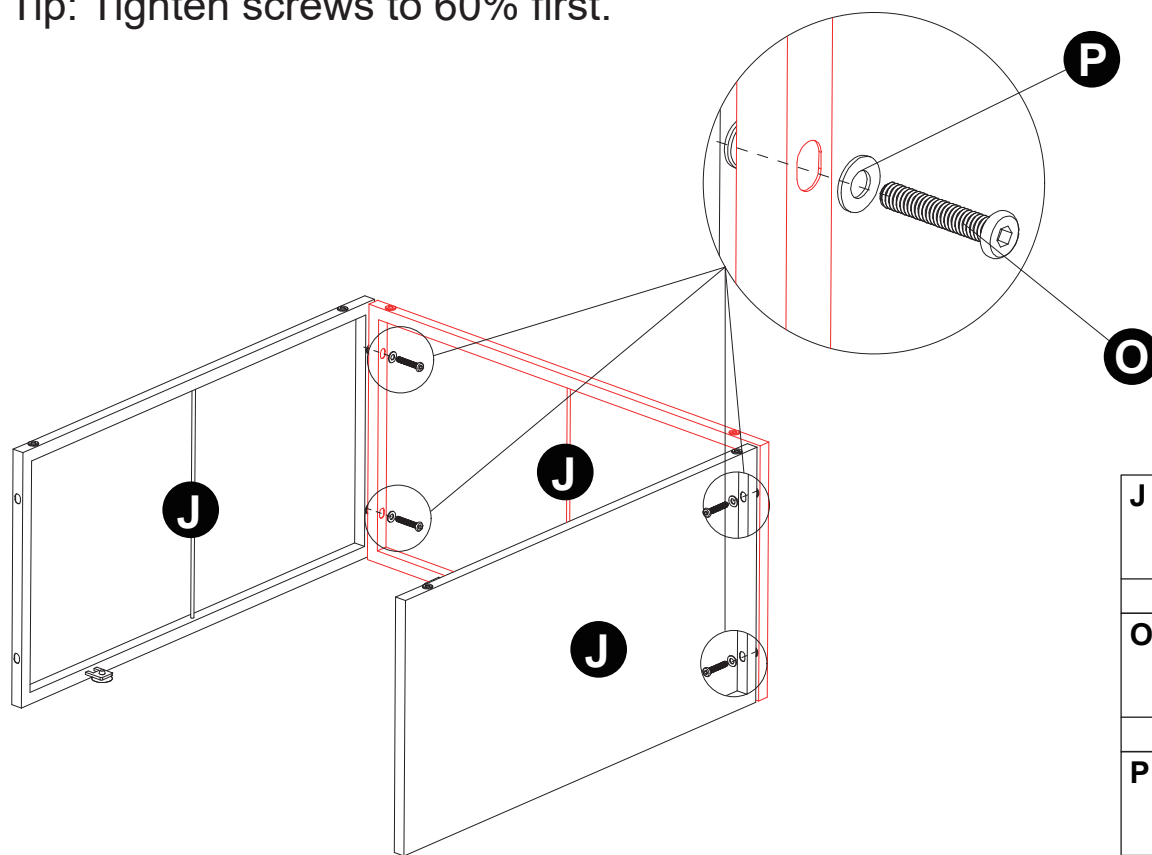
Tip: Tighten screws to 60% first.





<b>J</b>	
	X3
<b>O</b>	
	M6x32
	X4
<b>P</b>	
	M6
	X4

## 02

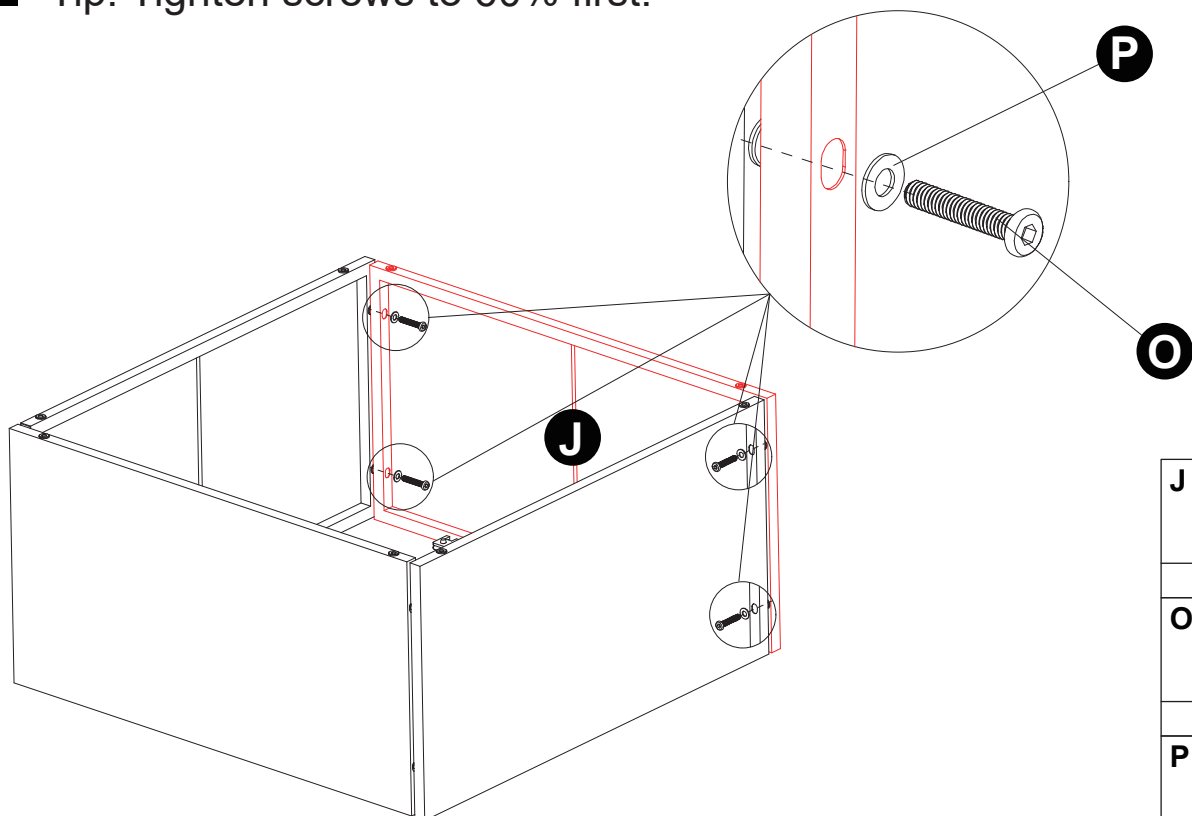
Tip: Tighten screws to 60% first.

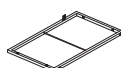

<b>J</b>	
	X1
<b>O</b>	
	M6x32
	X4
<b>P</b>	
	M6
	X4



## 03

# STEP

**03**

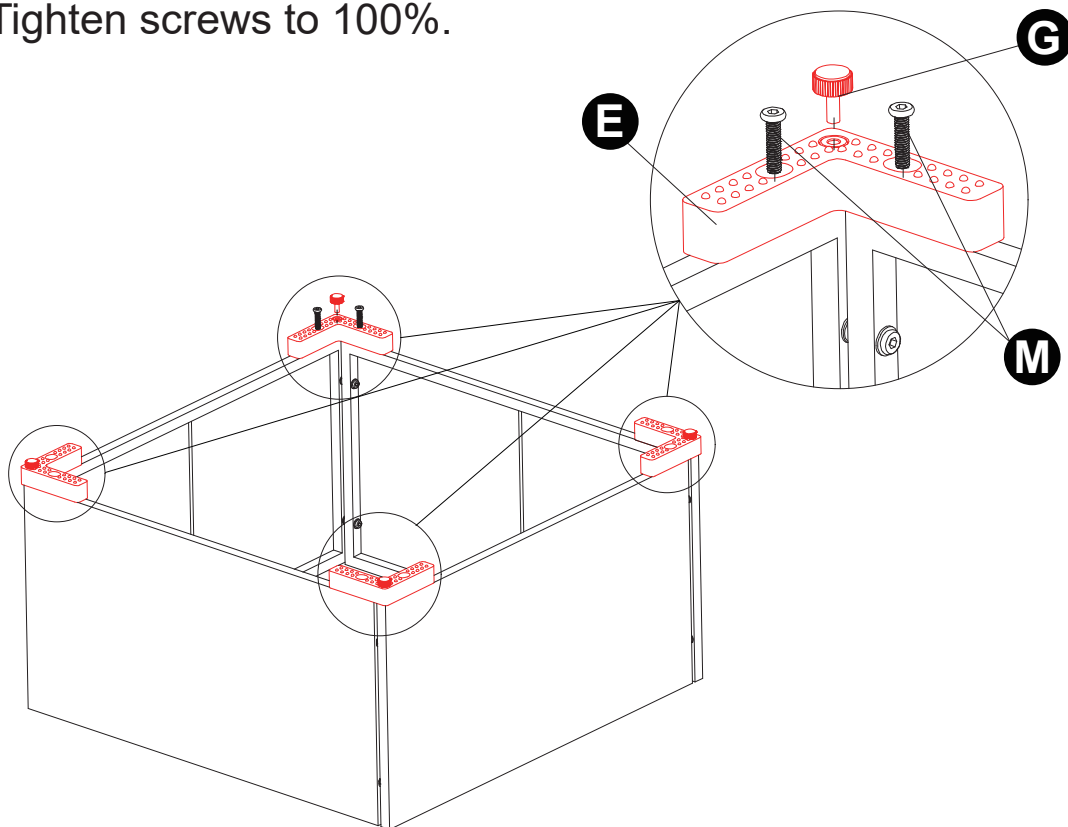
Tighten screws to 100%.



<b>E</b>	
	X4
<b>G</b>	
	X4
<b>M</b>	
	M6x25
	X8

**04**

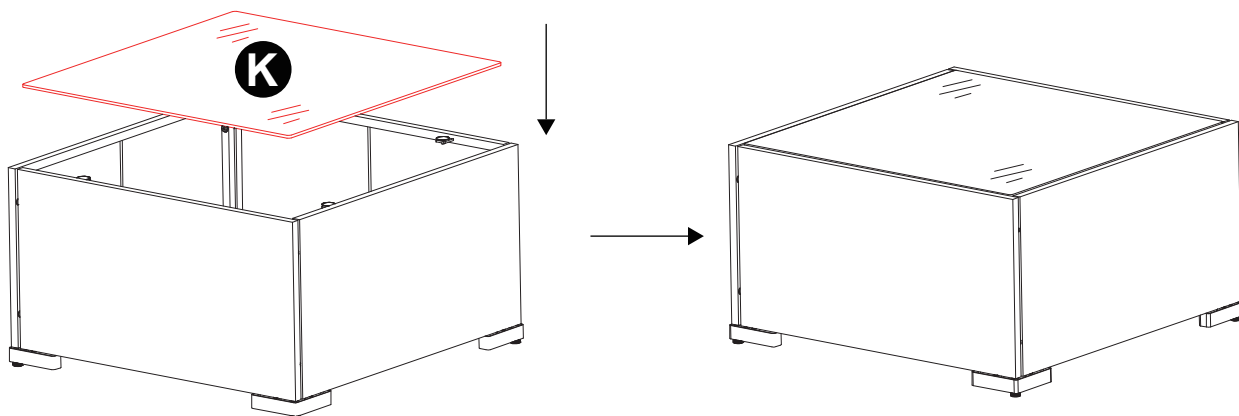





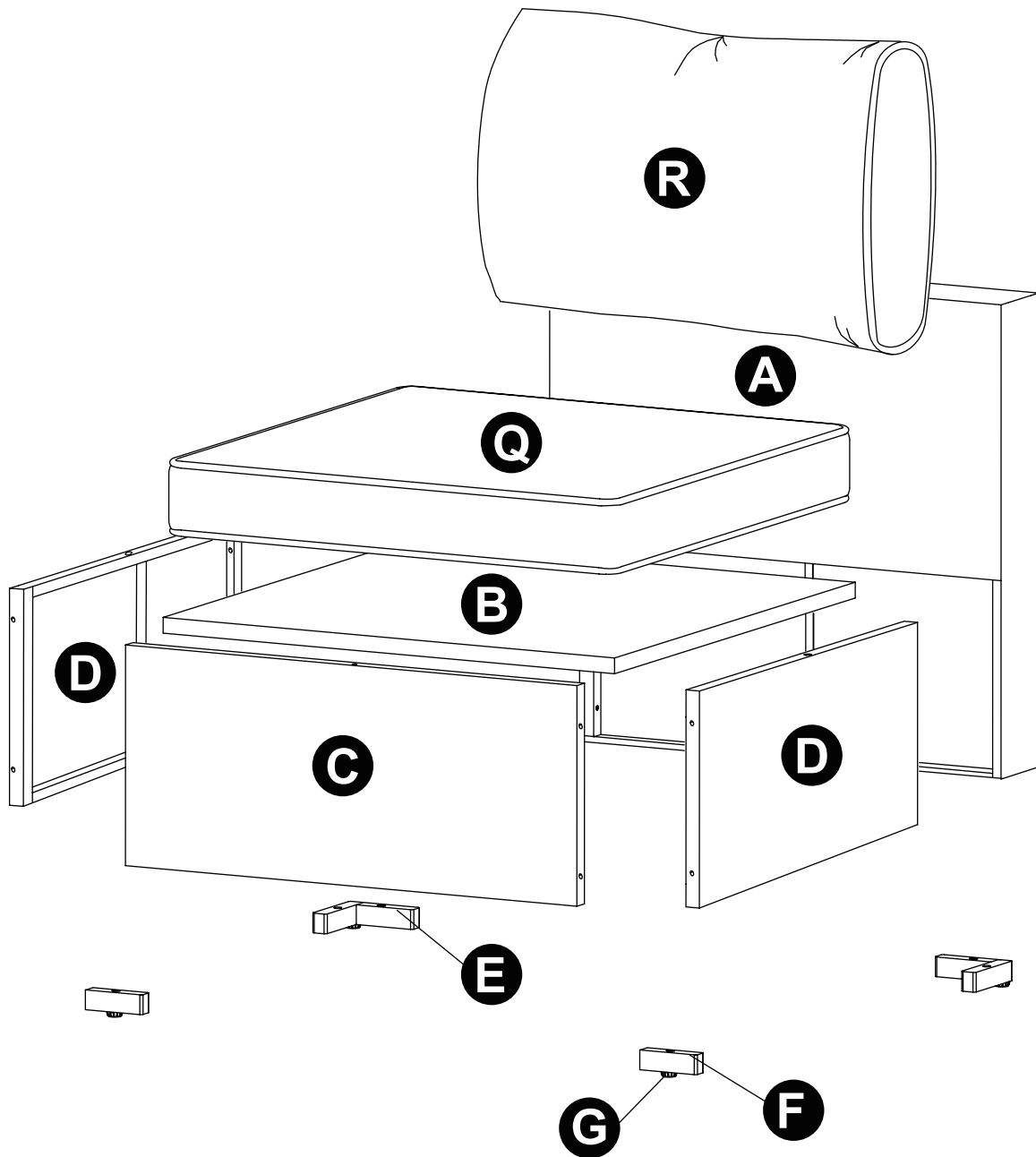

<b>K</b>	
	X1

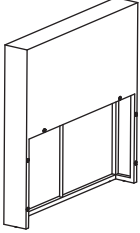
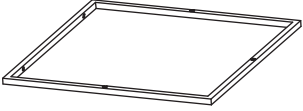
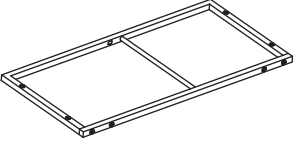
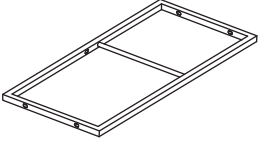
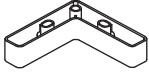
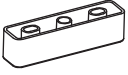
# PART LIST

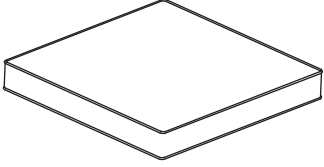
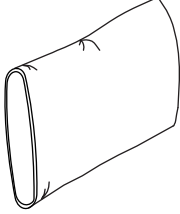
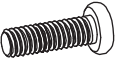

# PART LIST

<p><b>A</b></p> 	<p><b>B</b></p> 	<p><b>C</b></p> 
<p>x3PCS</p>	<p>x3PCS</p>	<p>x3PCS</p>
<p><b>D</b></p> 	<p><b>E</b></p> 	<p><b>F</b></p> 
<p>x6PCS</p>	<p>x6PCS</p>	<p>x6PCS</p>
<p><b>G</b></p> 	<p><b>Q</b></p> 	<p><b>R</b></p> 
<p>x12PCS</p>	<p>x3PCS</p>	<p>x3PCS</p>
<p><b>M</b></p>  <p>M6x25</p>	<p><b>O</b></p>  <p>M6x32</p>	<p><b>P</b></p>  <p>M6</p>
<p>x24PCS</p>	<p>x39PCS</p>	<p>x39PCS</p>
<p><b>W</b></p>  <p>M6</p>	<p><b>Z</b></p> 	
<p>x1PC</p>	<p>x4PCS</p>	

# STEP

## 01

Tighten screws to 100%.

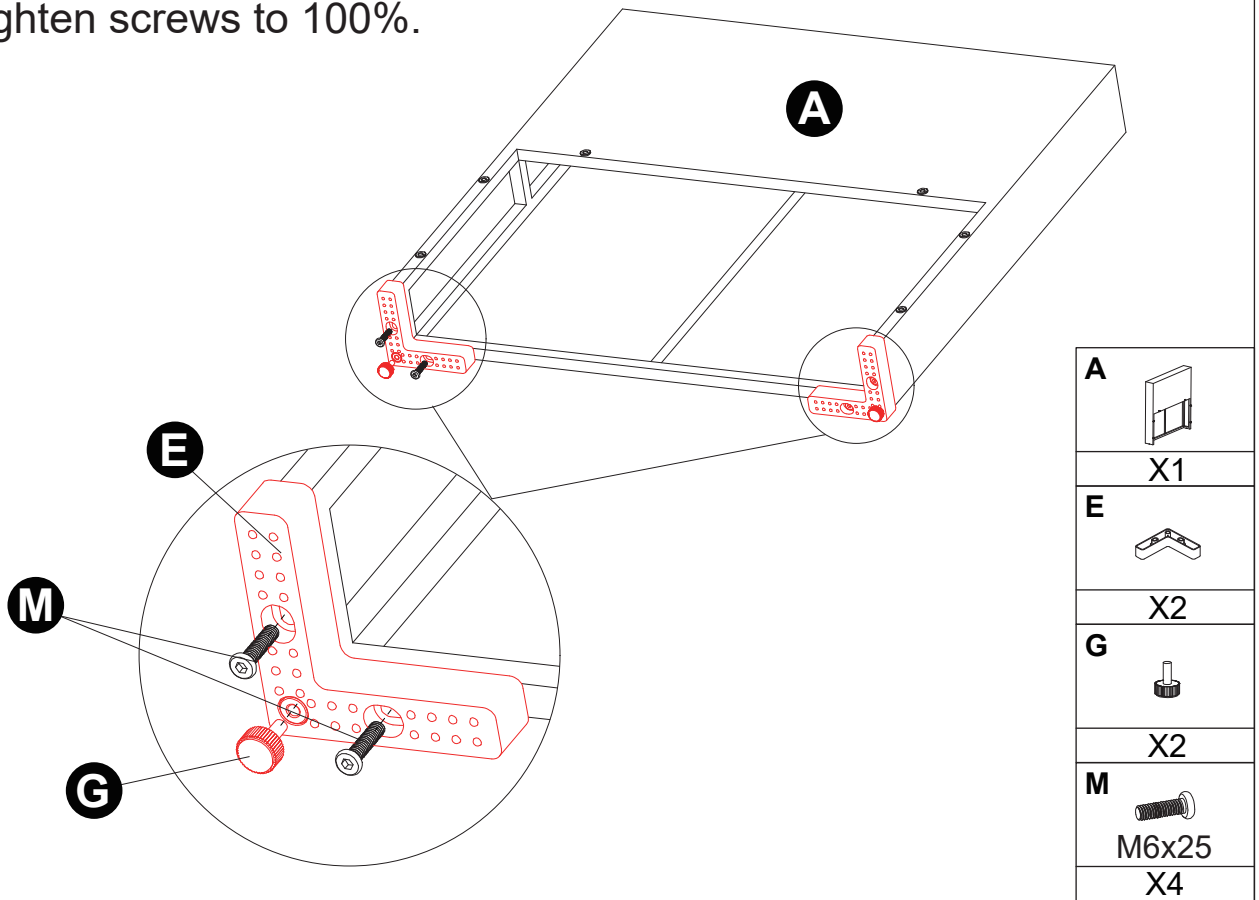

## 02

Tip: Tighten screws to 60% first.

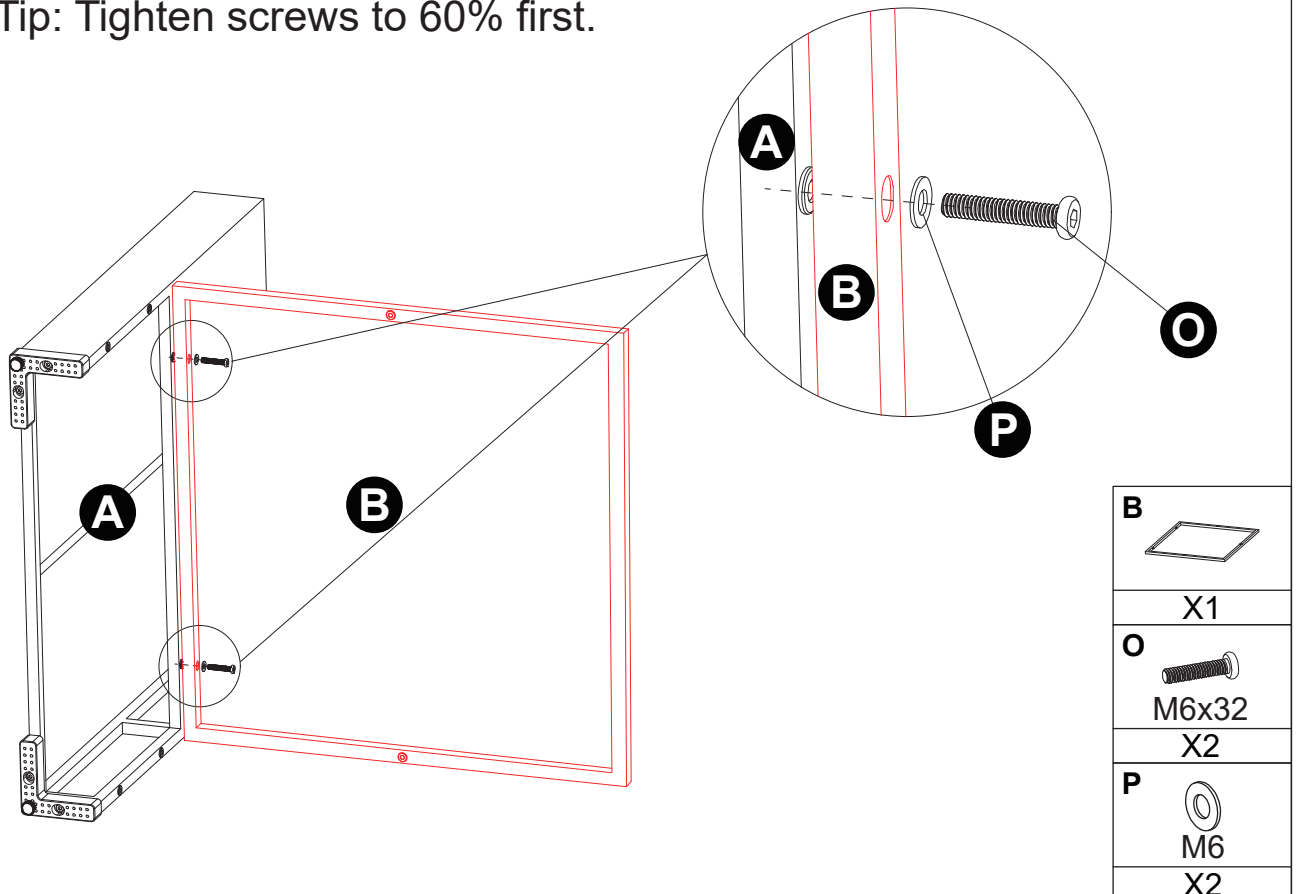

# STEP

## 03

Tip: Tighten screws to 60% first.

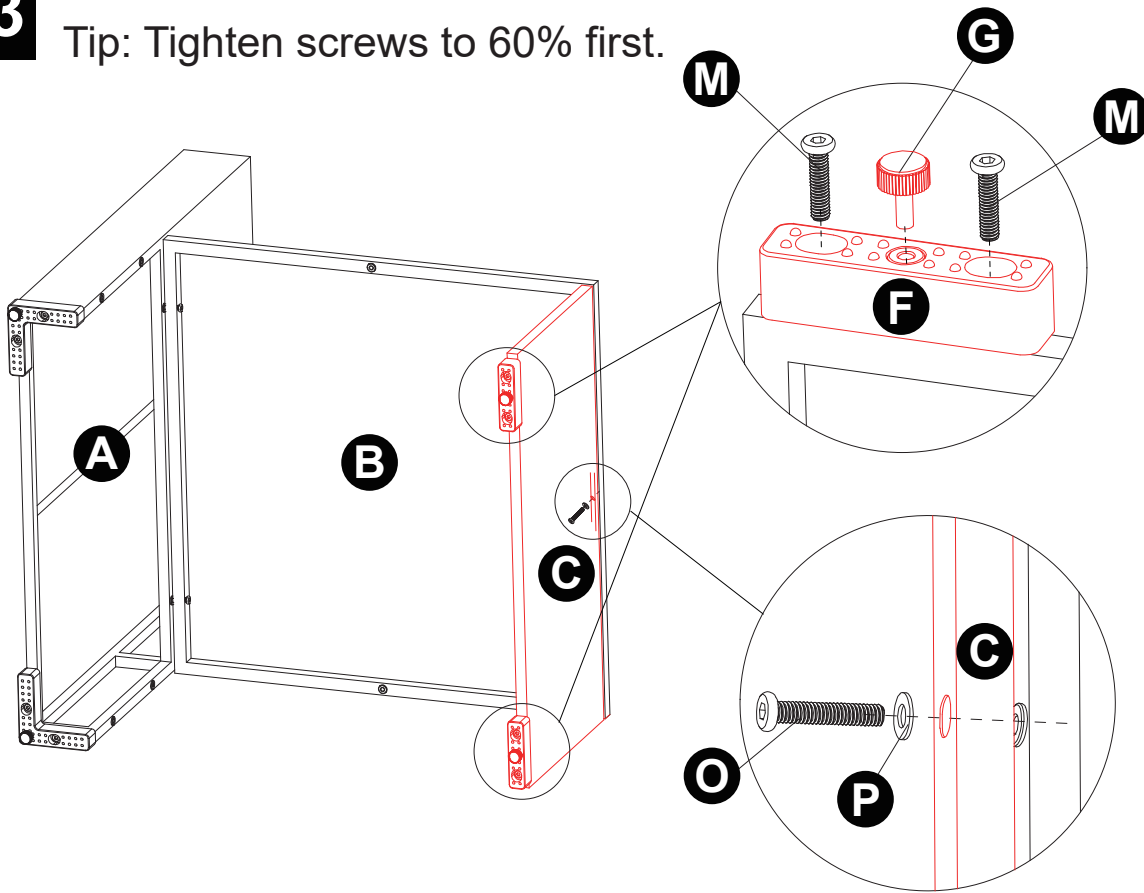

<b>C</b>	
	X1
<b>F</b>	
	X2
<b>G</b>	
	X2
<b>M</b>	
	M6x25 X4
<b>O</b>	
	M6x32 X1
<b>P</b>	
	M6 X1

## 04

Tip: Tighten screws to 60% first.

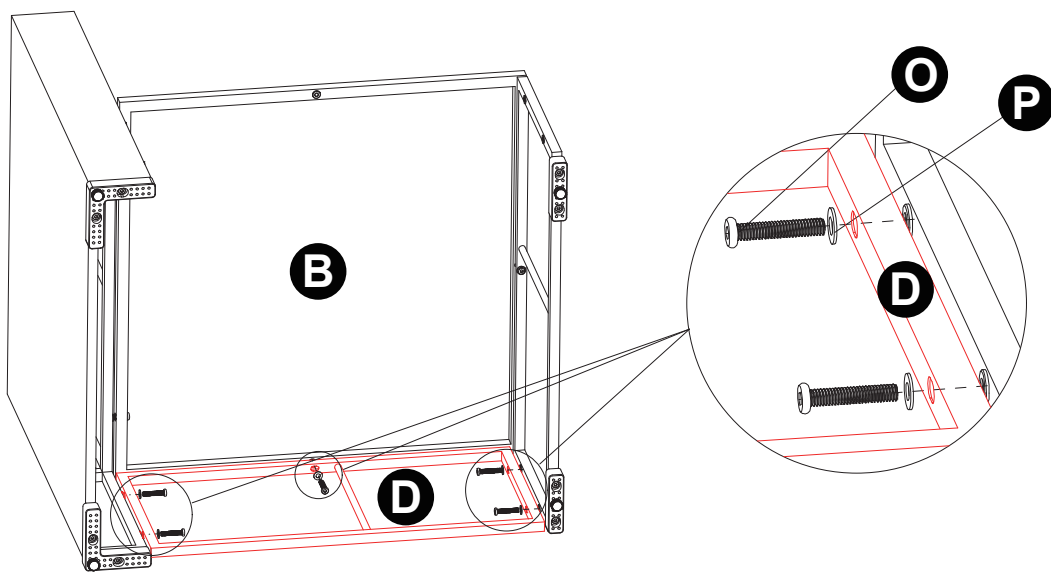

<b>D</b>	
	X1
<b>O</b>	
	M6x32 X5
<b>P</b>	
	M6 X5

## 05

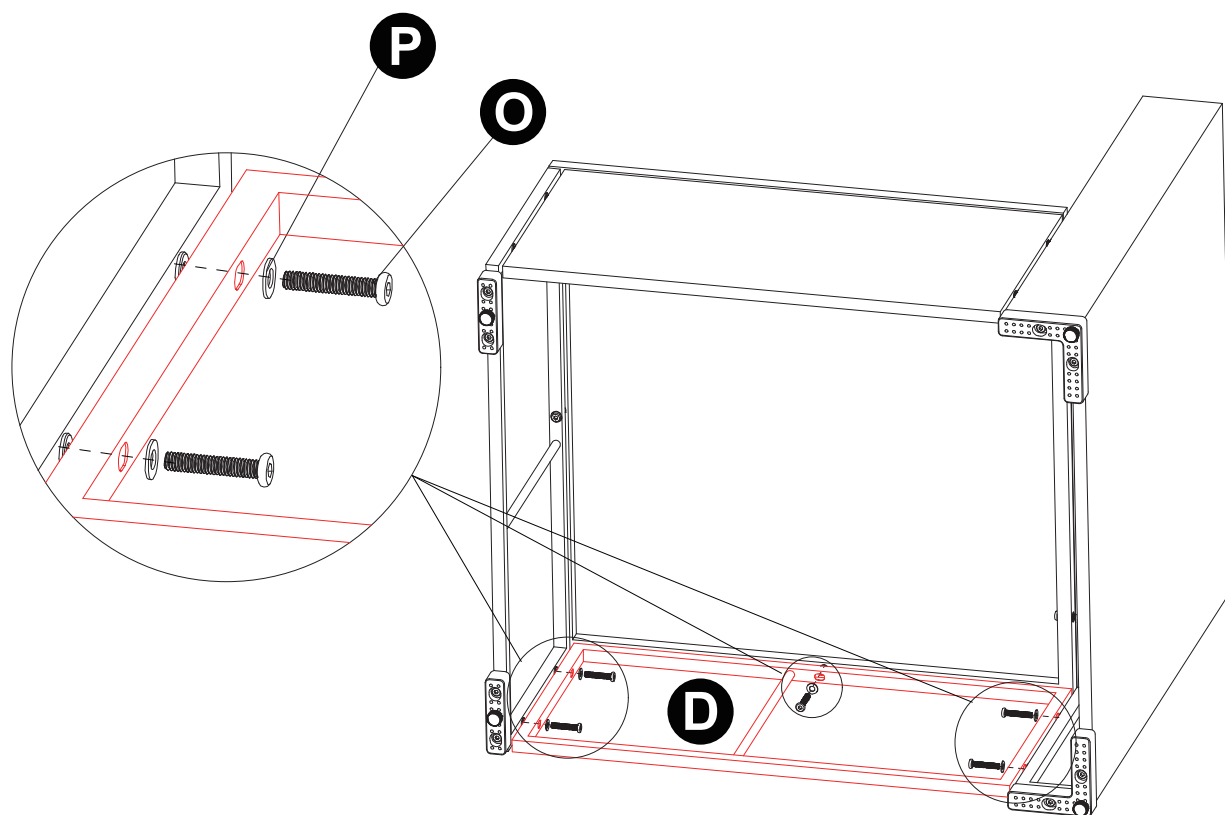

Tighten screws to 100%.

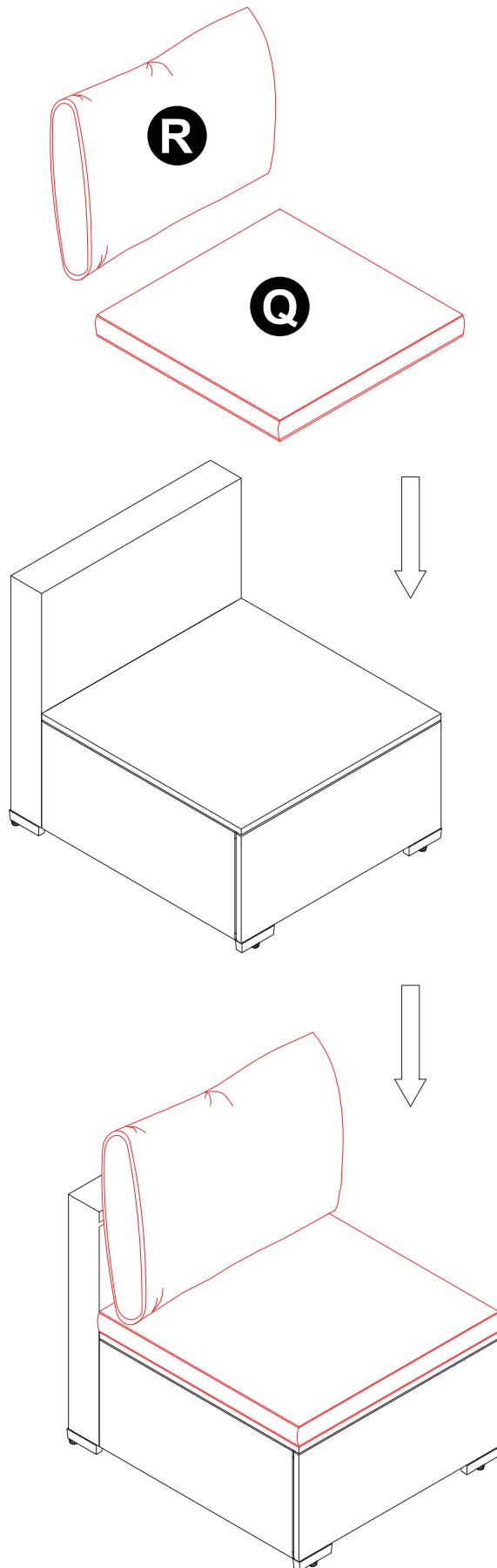

<b>D</b>	
	X1
<b>O</b>	
	M6x32
	X5
<b>P</b>	
	M6
	X5

06

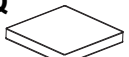

Q	
X1	
R	
X1	

## 07

Please install clip Z as shown in the illustration.

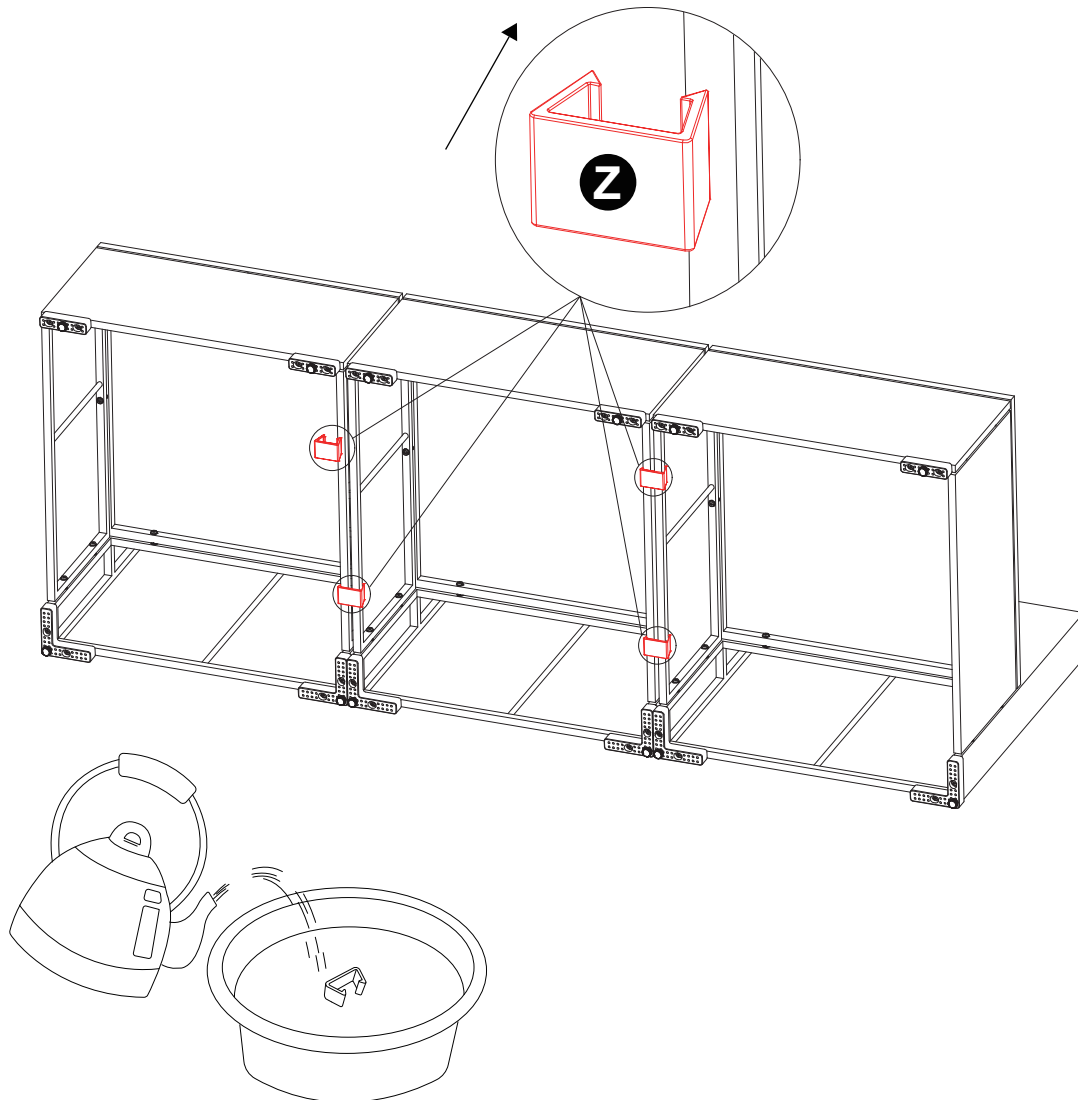

**1.** In order to increase the toughness of the sofa fixed buckle, please soak it in hot water for 10 minutes before use.

**2.** When in use, first to snap one side of the buckle into the metal frame, and then force the other side into all the frame.

**Z**



X4

**08**

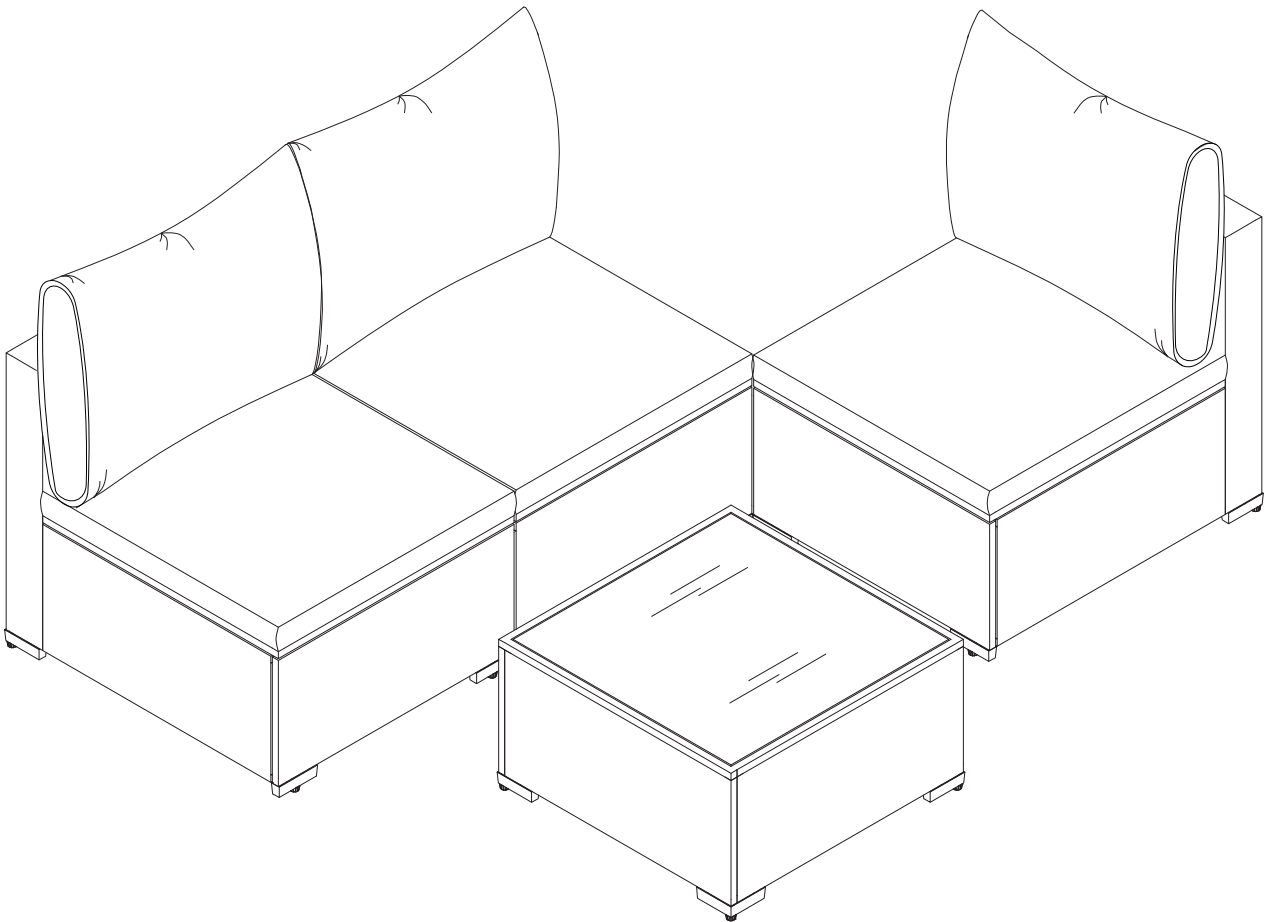

**EN**

## AFTER-SALE SERVICE

If you have any suggestions for our products or notice any quality issues, please contact us first. Our after-sales team will respond within 24 hours and will do everything possible to provide you with a satisfactory solution.

### Guaranteed Customer Service

Your shopping experience is very important to us!

Feel unsatisfied? **Contact us!**

Have any questions? **Contact us!**

Wanna Share how wonderful our smart products make your home?

Share your pictures with us.

Any suggestions? **Contact us!**

We will check and give feedback.



**Patiofurniture Serviceteam@outlook.com**



# INSTRUCTION

---

## 2PCS CORNER SOFA & SINGLE SOFA

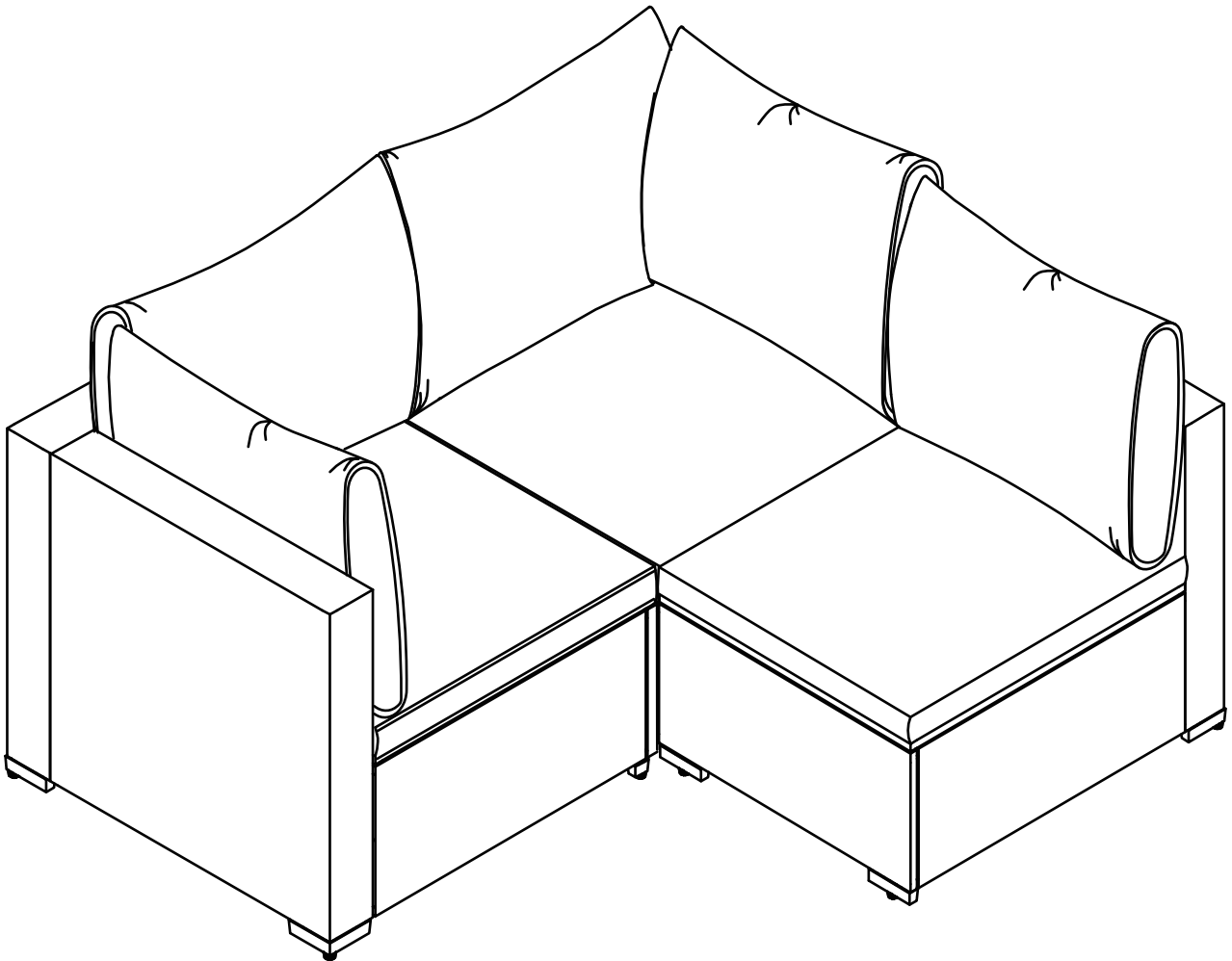

**After-sales mailbox:  
Patiofurniture Serviceteam@outlook.com**

# NOTICE

---

**EN**

**Please keep these instructions for future reference.**

**Dear Customer**

● Thank you for your purchase. When you receive the product, please make sure that all the parts are intact. If any parts are missing, please contact us promptly to request replacement parts.

● Then follow the entire installation instructions to install.

● Each part is crucial, so please be careful not to lose any. It is recommended to store parts with different lettered identifiers in separate boxes or bags to avoid confusion during installation.

**A** . The outer box is damaged

**B** . The product is damaged / bent / cracked while you open the box

**C** . The parts / accessories / assembly tools are missing

**D** . The instructions are not clear and can not be referred

**E** . The product has functional problems

**F** . Other aspects that you are not satisfied with

**Please feel free to contact us for help, and provide the following information:**

**Platform/Shop name/Order id/Buyer's name/Receiver's address/Problem description/Problem pictures**

([Patiofurniture Serviceteam@outlook.com](mailto:Patiofurniture Serviceteam@outlook.com)) will reply within 24 hours and will do our best to resolve the problem for you.







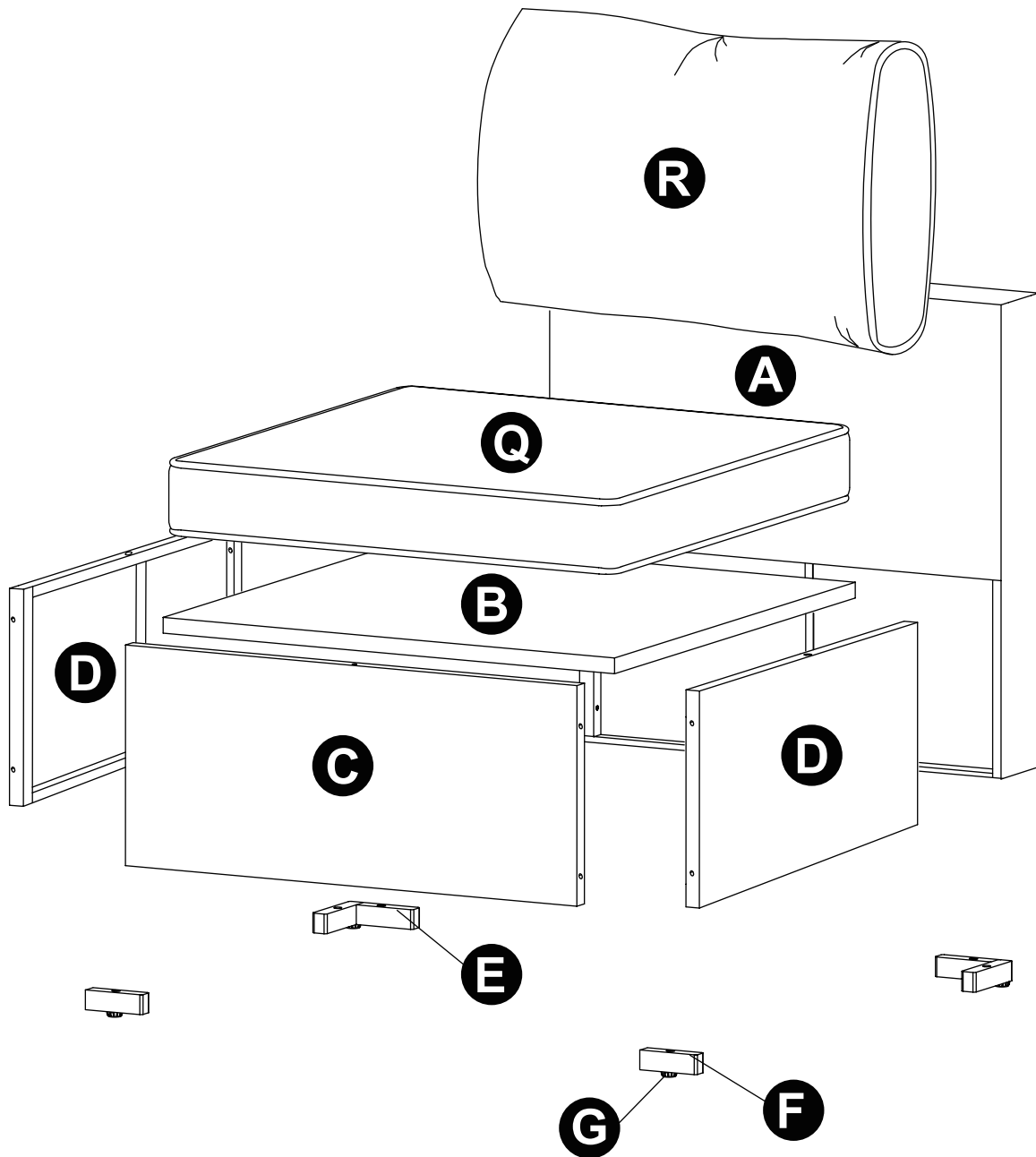

**Note: First tighten each screw by 60%, and then tighten it according to each part.**

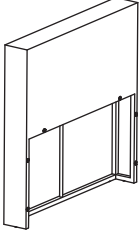
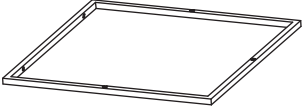
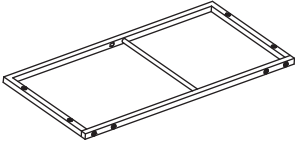
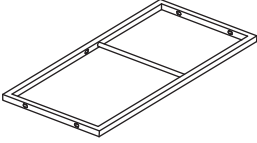

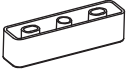
# PART LIST

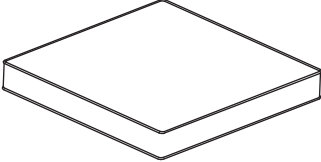
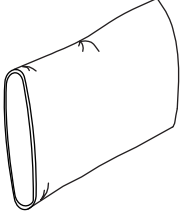
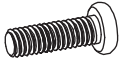

# PART LIST

<p><b>A</b></p> 	<p><b>B</b></p> 	<p><b>C</b></p> 
<p>x1PC</p>	<p>x1PC</p>	<p>x1PC</p>
<p><b>D</b></p> 	<p><b>E</b></p> 	<p><b>F</b></p> 
<p>x2PCS</p>	<p>x2PCS</p>	<p>x2PCS</p>
<p><b>G</b></p> 	<p><b>Q</b></p> 	<p><b>R</b></p> 
<p>x4PCS</p>	<p>x1PC</p>	<p>x1PC</p>
<p><b>M</b></p>  <p>M6x25</p>	<p><b>O</b></p>  <p>M6x32</p>	<p><b>P</b></p>  <p>M6</p>
<p>x8PCS</p>	<p>x13PCS</p>	<p>x13PCS</p>
<p><b>W</b></p>  <p>M6</p>	<p><b>Z</b></p> 	
<p>x1PC</p>	<p>x2PCS</p>	

# STEP

## 01

Tighten screws to 100%.

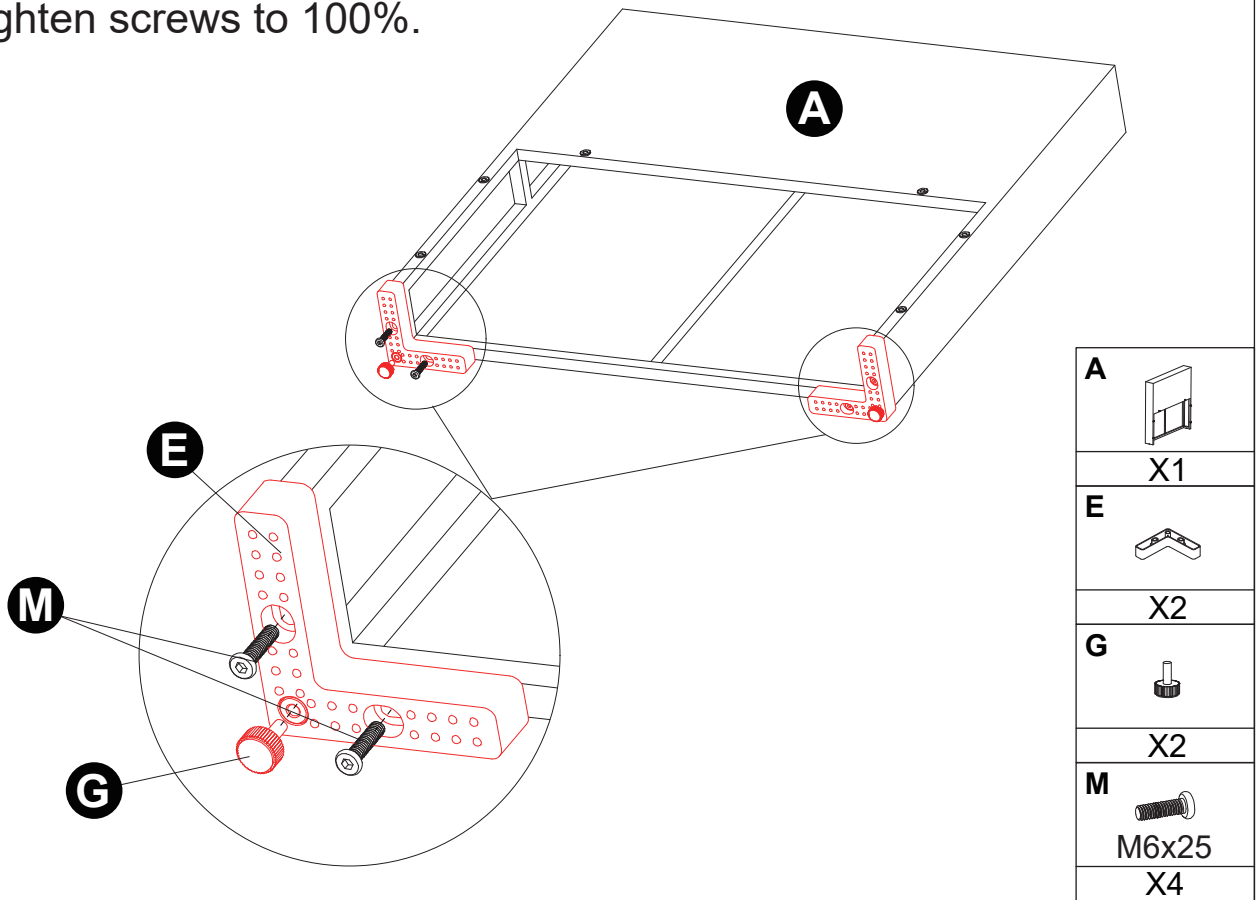

## 02

Tip: Tighten screws to 60% first.

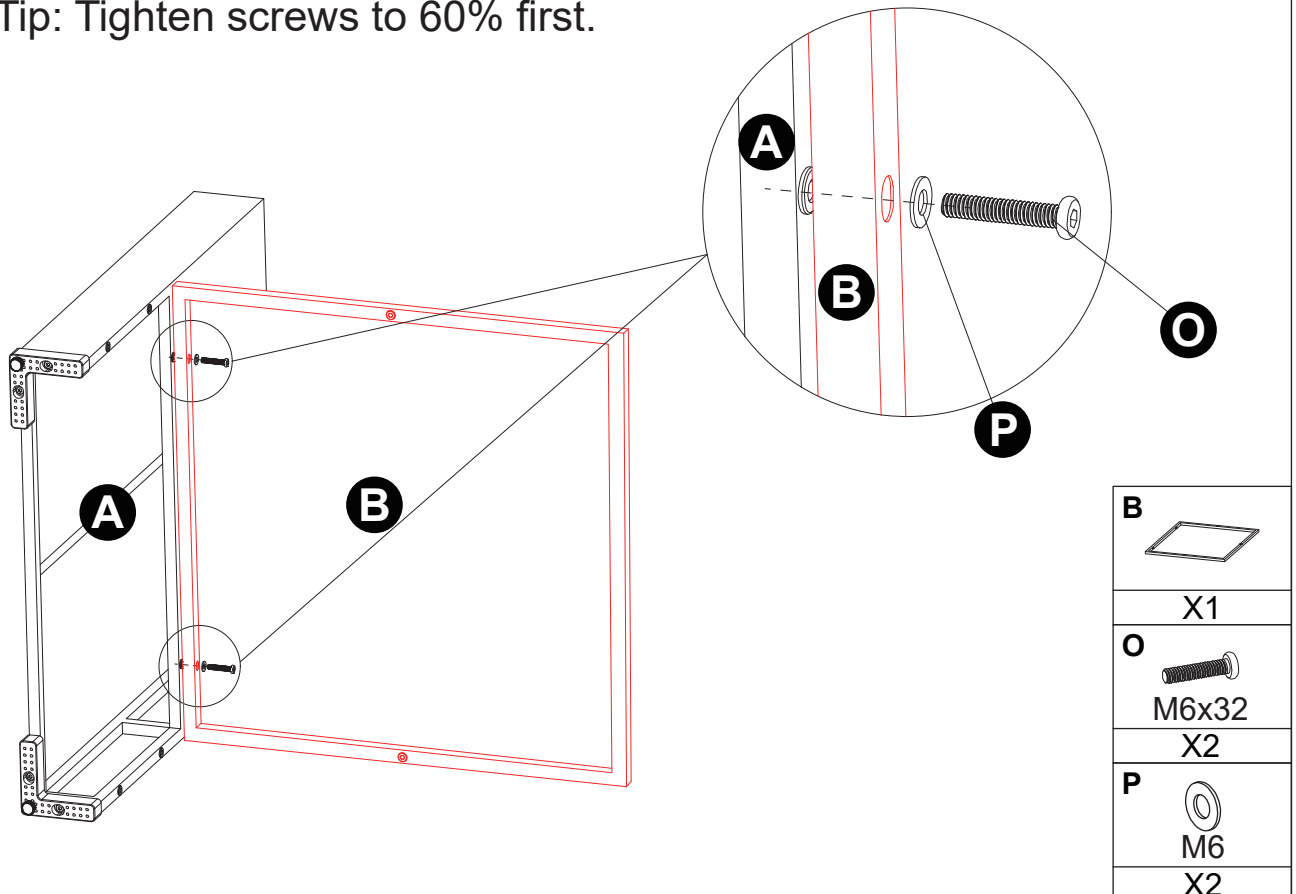

## 03

# STEP

## 03

Tip: Tighten screws to 60% first.

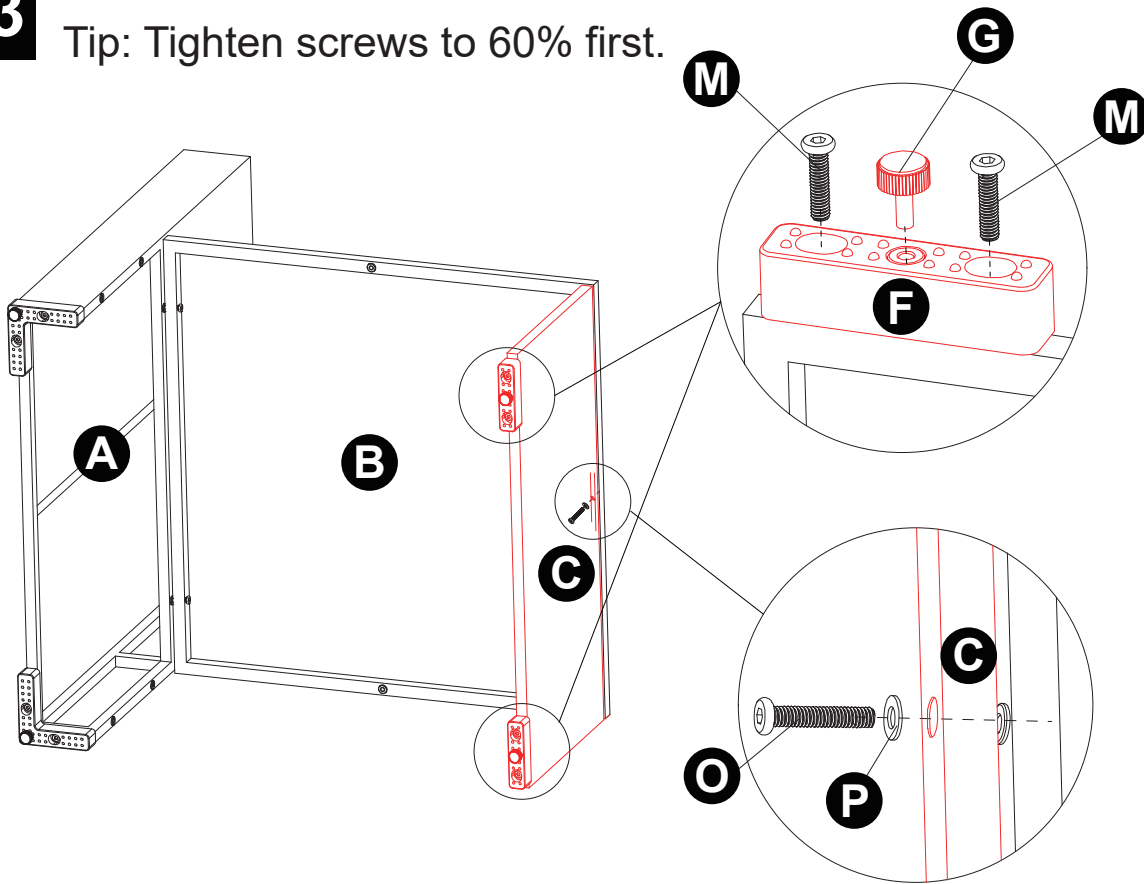

<b>C</b>	
	X1
<b>F</b>	
	X2
<b>G</b>	
	X2
<b>M</b>	
	M6x25 X4
<b>O</b>	
	M6x32 X1
<b>P</b>	
	M6 X1

## 04

Tip: Tighten screws to 60% first.

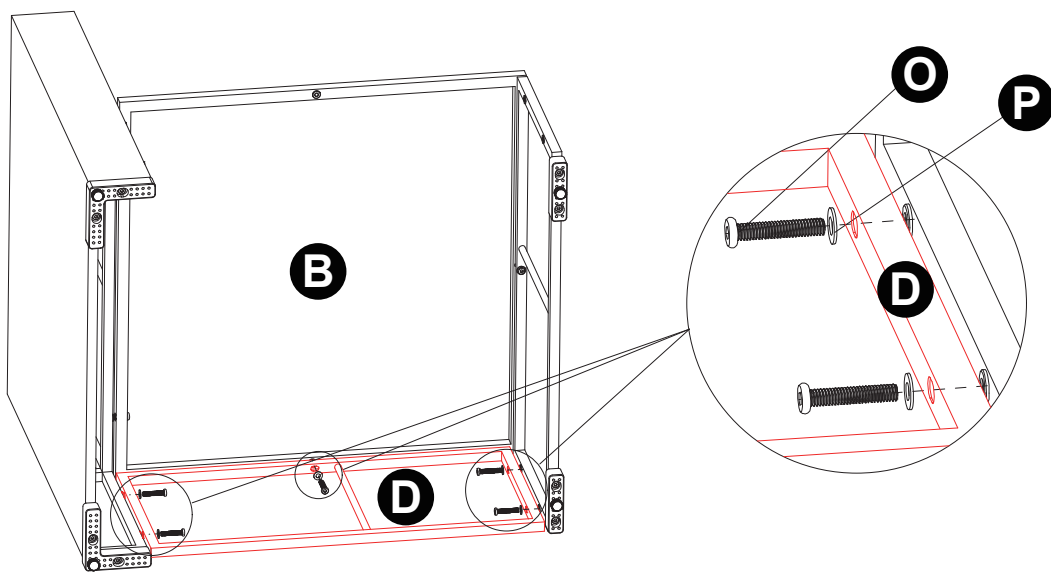

<b>D</b>	
	X1
<b>O</b>	
	M6x32 X5
<b>P</b>	
	M6 X5

## 05

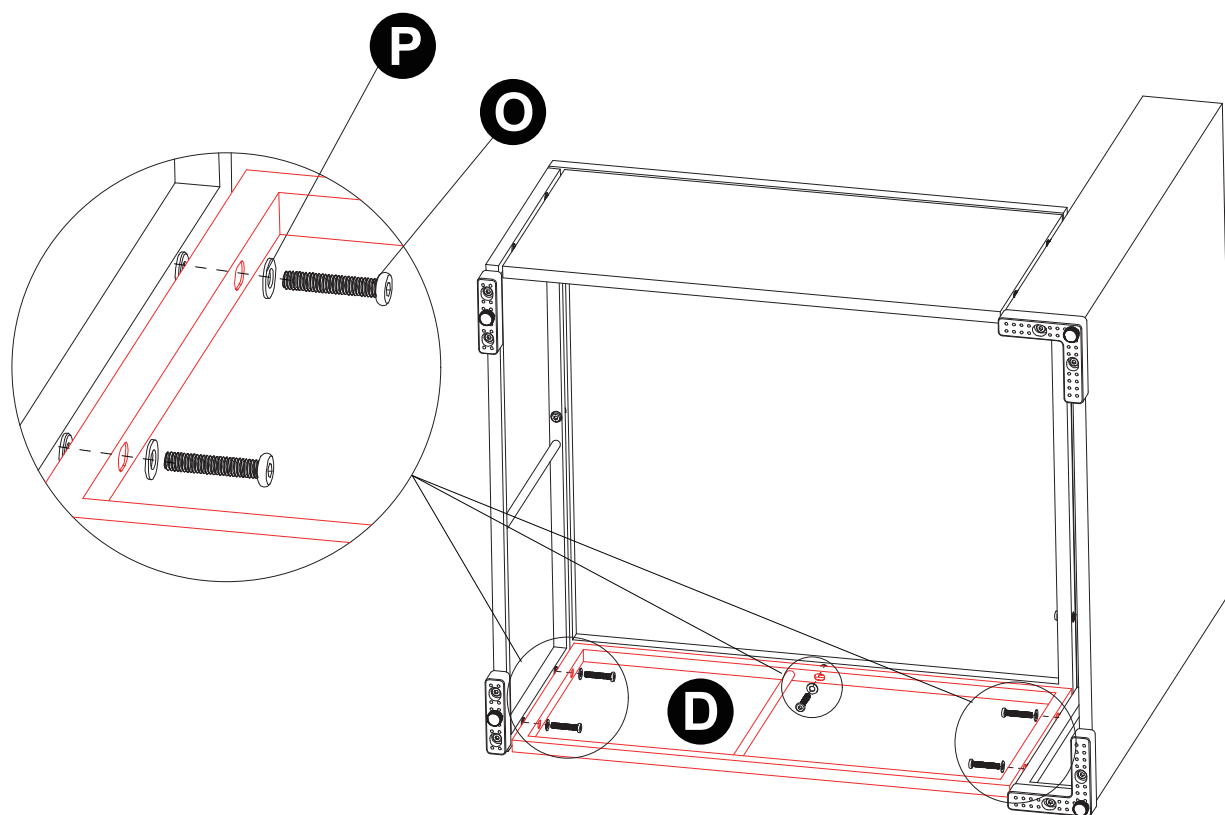

Tighten screws to 100%.

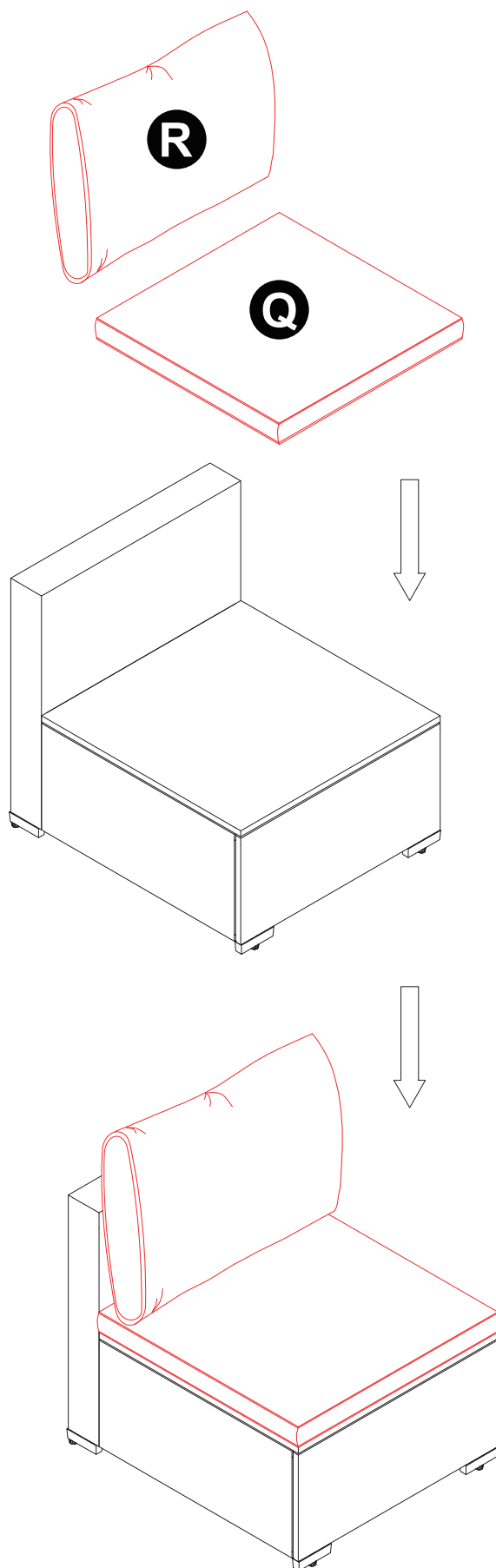

<b>D</b>	
	X1
<b>O</b>	
	M6x32
	X5
<b>P</b>	
	M6
	X5

06

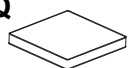





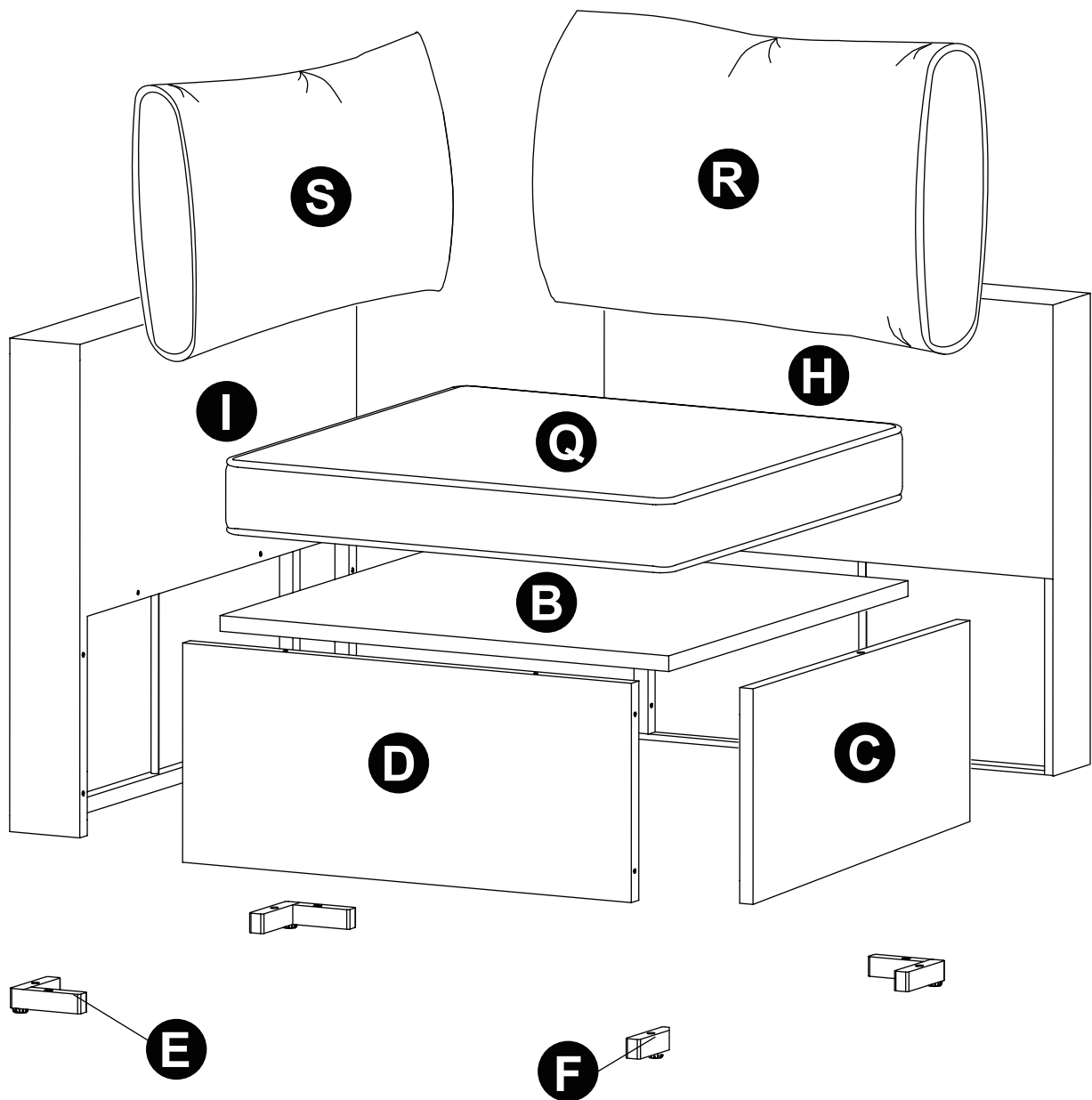

<b>Q</b>	
	X1
<b>R</b>	
	X1

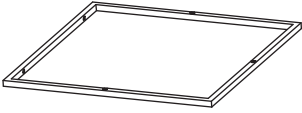
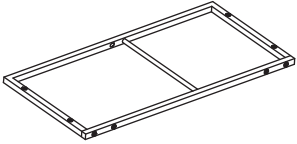
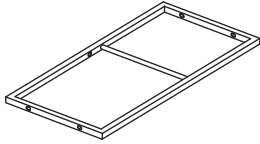

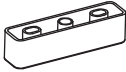

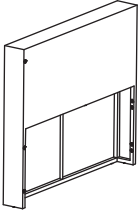
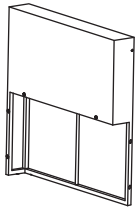
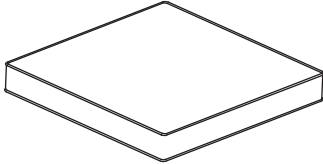
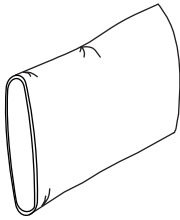
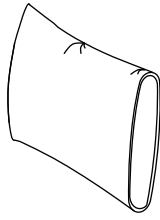
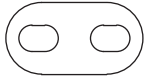
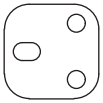

# PART LIST

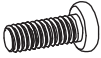

# PART LIST

<p><b>B</b></p> 	<p><b>C</b></p> 	<p><b>D</b></p> 
<p>x2PCS</p>	<p>x2PCS</p>	<p>x2PCS</p>
<p><b>E</b></p> 	<p><b>F</b></p> 	<p><b>G</b></p> 
<p>x6PCS</p>	<p>x2PCS</p>	<p>x8PCS</p>
<p><b>H</b></p> 	<p><b>I</b></p> 	<p><b>Q</b></p> 
<p>x2PCS</p>	<p>x2PCS</p>	<p>x2PCS</p>
<p><b>R</b></p> 	<p><b>S</b></p> 	<p><b>T</b></p> 
<p>x2PCS</p>	<p>x2PCS</p>	<p>x2PCS</p>
<p><b>U</b></p> 	<p><b>Z</b></p> 	
<p>x4PCS</p>	<p>x2PCS</p>	

# PART LIST

<b>L</b>  M6x15	<b>M</b>  M6x25	<b>N</b>  M6x35
x16PCS	x16PCS	x2PCS
<b>O</b>  M6x32	<b>P</b>  M6	<b>W</b>  M6
x20PCS	x36PCS	x1PC

# STEP

**01**

Tighten screws to 100%.

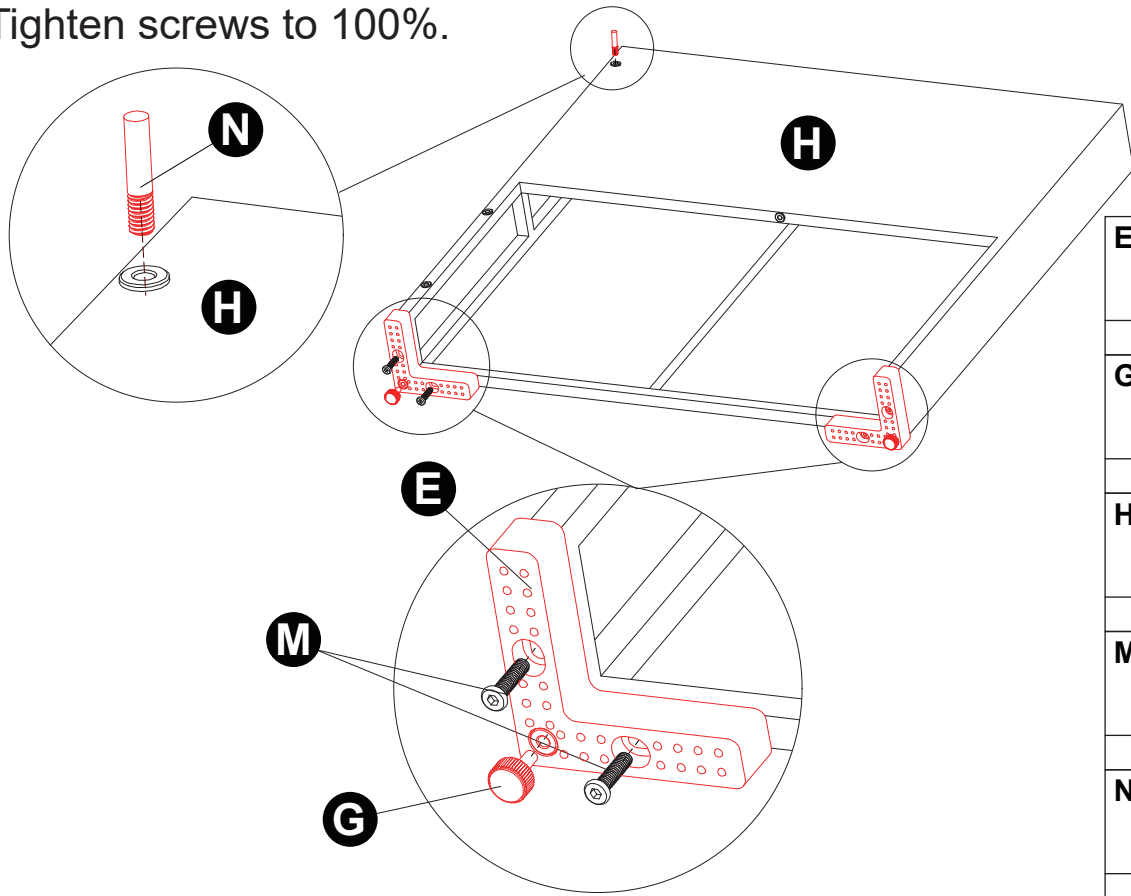

<b>E</b>	
	X2
<b>G</b>	
	X2
<b>H</b>	
	X1
<b>M</b>	
	X4
<b>N</b>	
	X1

**02**

Tighten screws to 100%.

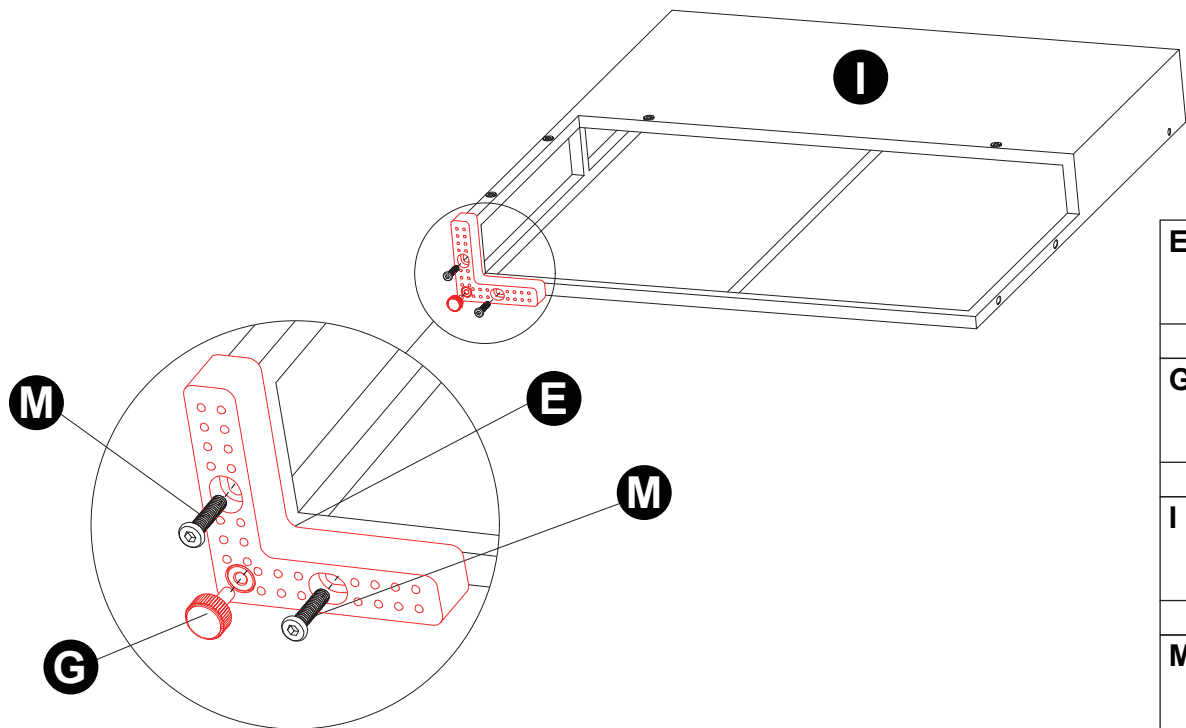



<b>E</b>	
	X1
<b>G</b>	
	X1
<b>I</b>	
	X1
<b>M</b>	
	X2

## 03

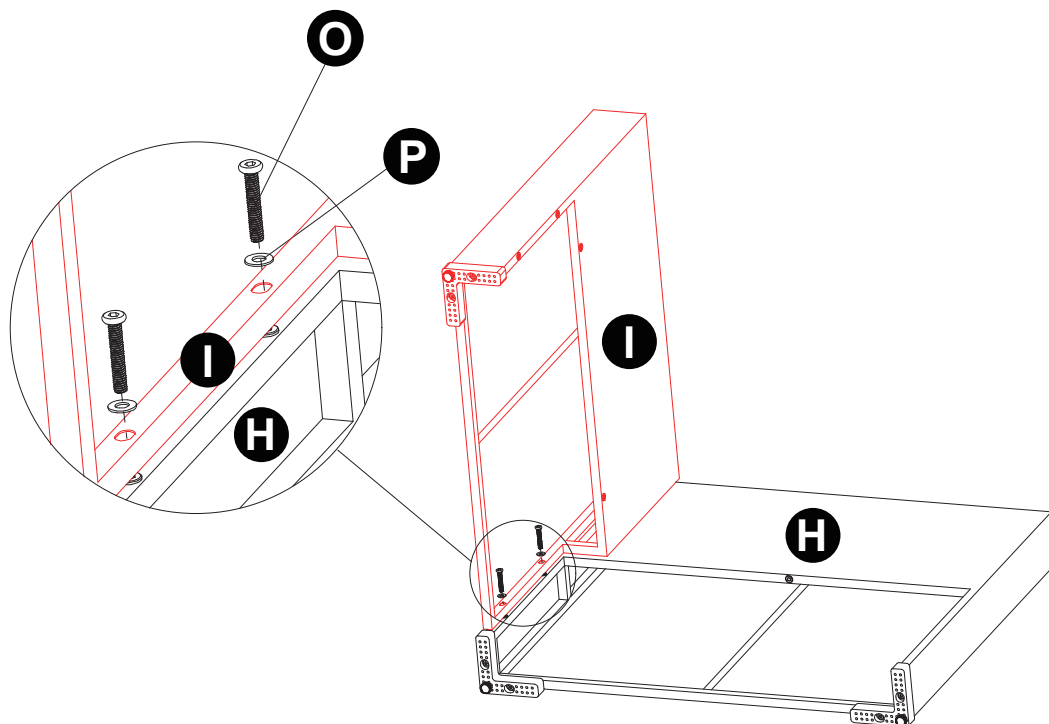
Tip: Tighten screws to 60% first.





<b>O</b>	
	M6x32
	X2
<b>P</b>	
	M6
	X2

## 04

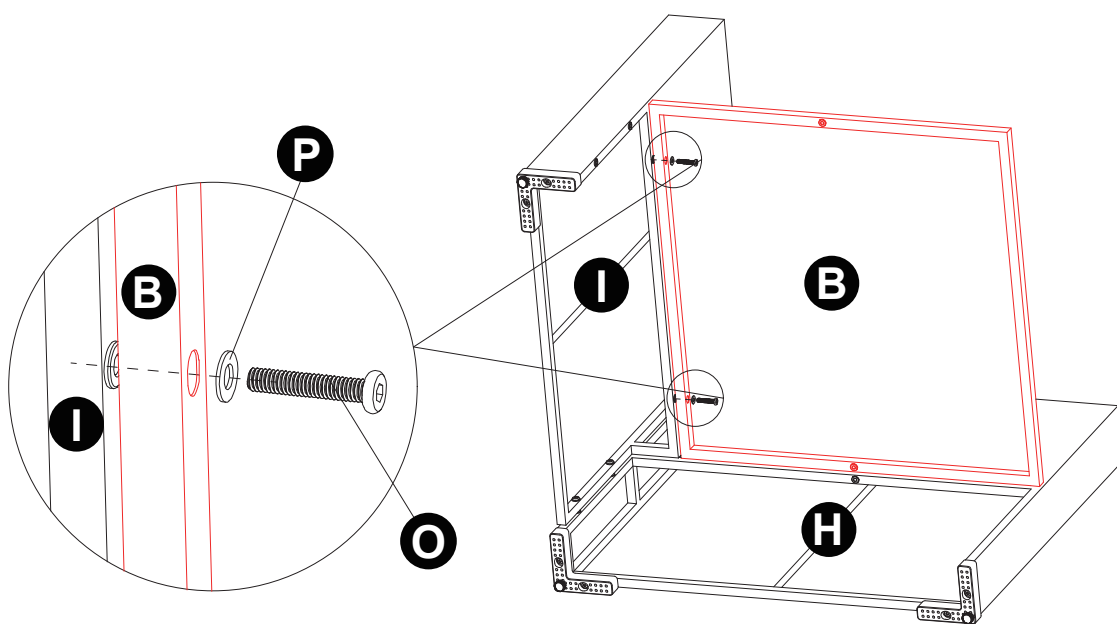
Tip: Tighten screws to 60% first.



<b>B</b>	
	X1
<b>O</b>	
	M6x32
	X2
<b>P</b>	
	M6
	X2

# STEP

## 05

Tip: Tighten screws to 60% first.

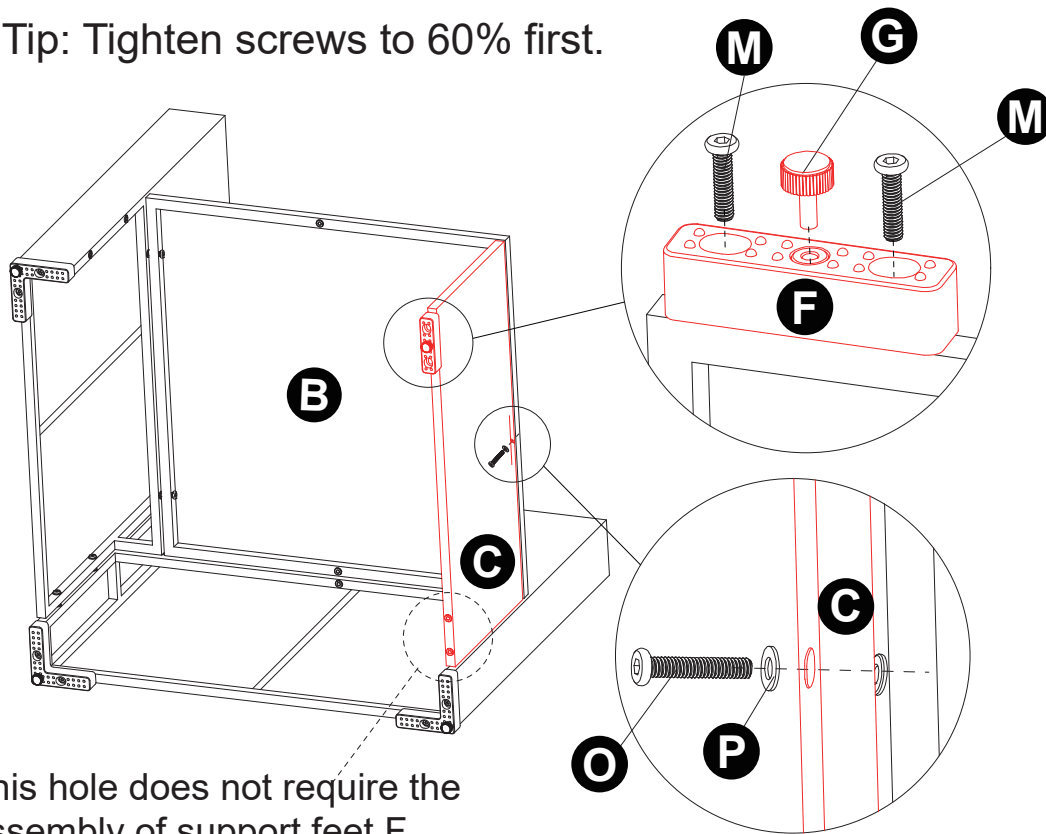

This hole does not require the assembly of support feet F.

<b>C</b>	
	X1
<b>F</b>	
	X1
<b>G</b>	
	X1
<b>M</b>	
	M6x25
	X2
<b>O</b>	
	M6x32
	X1
<b>P</b>	
	M6
	X1

## 06

Tip: Tighten screws to 60% first.

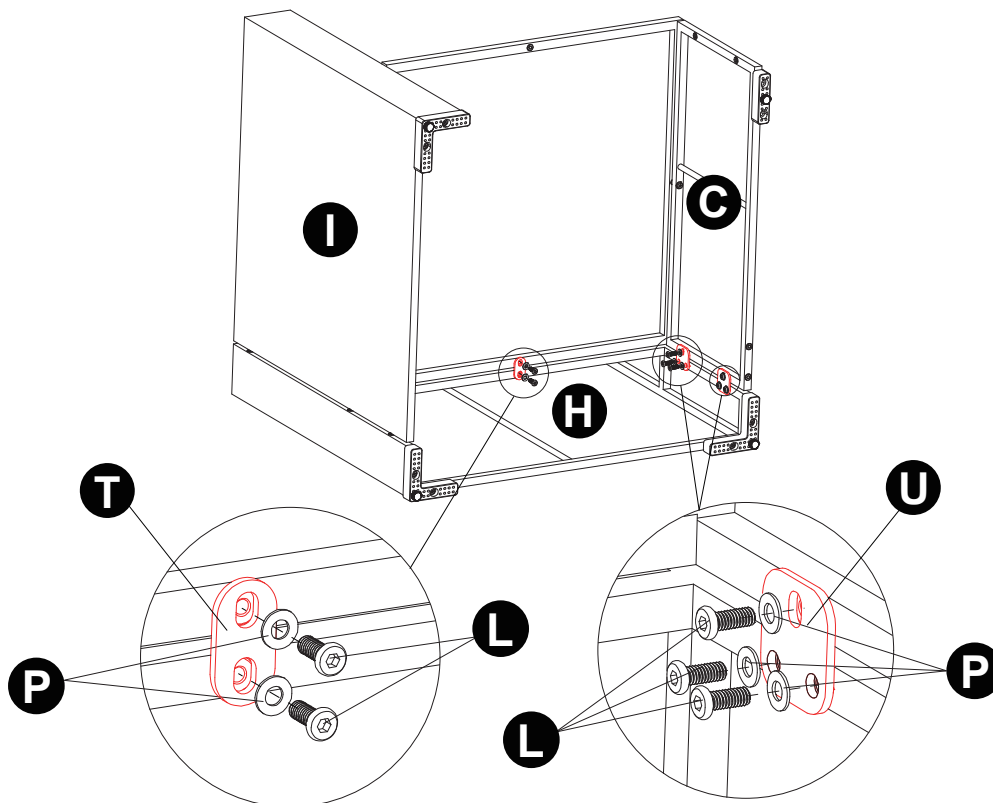



<b>L</b>	
	M6x15
	X8
<b>P</b>	
	M6
	X8
<b>T</b>	
	X1
<b>U</b>	
	X2

## 07

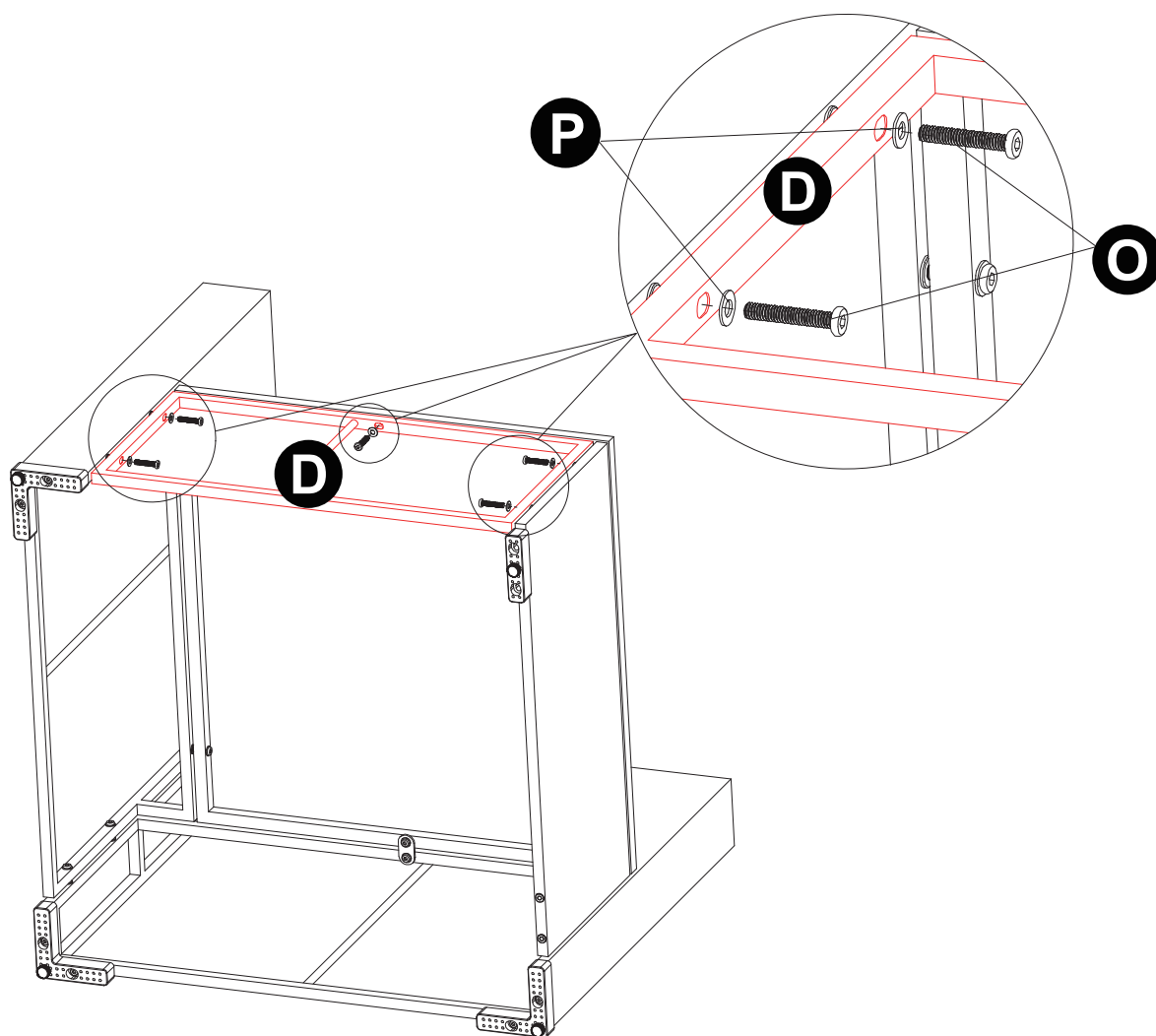

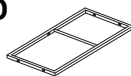
Tighten screws to 100%.

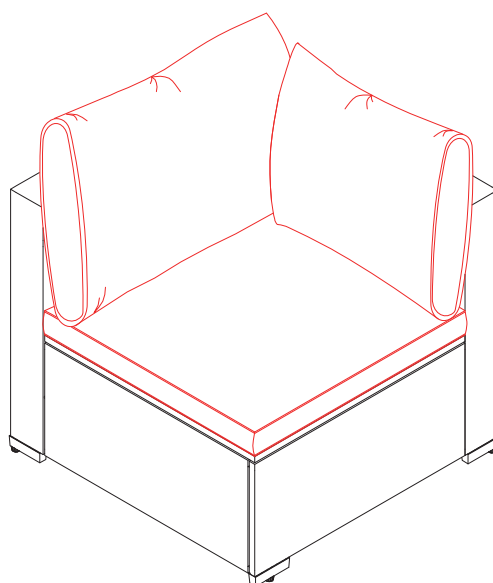
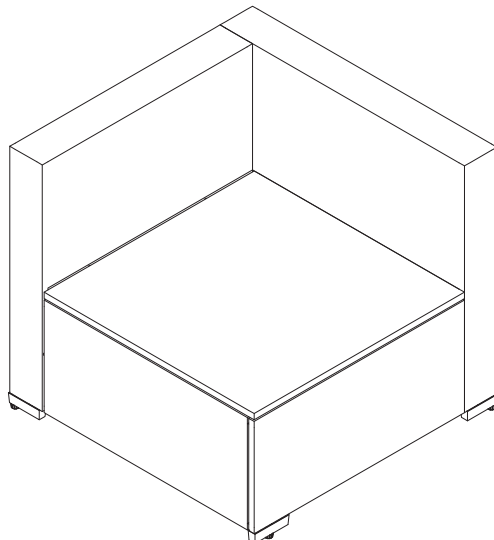
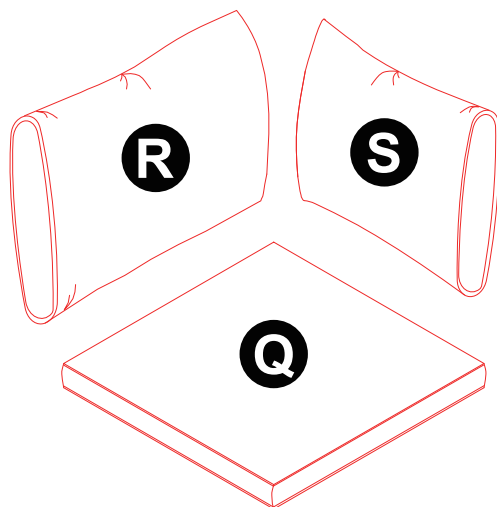

<b>D</b>	
	X1
<b>O</b>	
	M6x32
	X5
<b>P</b>	
	M6
	X5

08

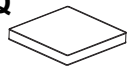

<b>Q</b>	
	X1
<b>R</b>	
	X1
<b>S</b>	
	X1

## 09

Please install clip Z as shown in the illustration.

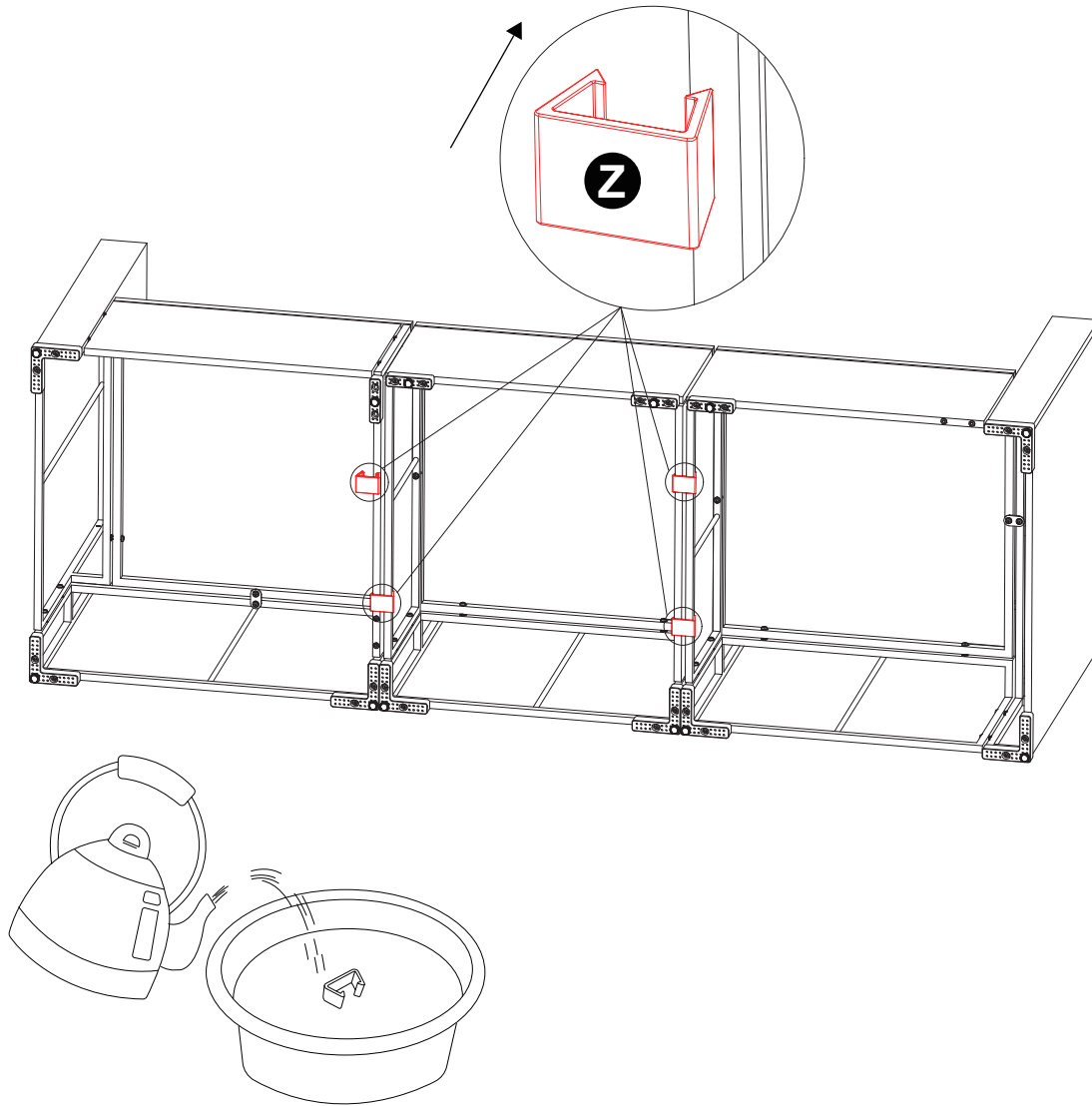

**1.** In order to increase the toughness of the sofa fixed buckle, please soak it in hot water for 10 minutes before use.

**2.** When in use, first to snap one side of the buckle into the metal frame, and then force the other side into all the frame.

**Z**



X4

**10**

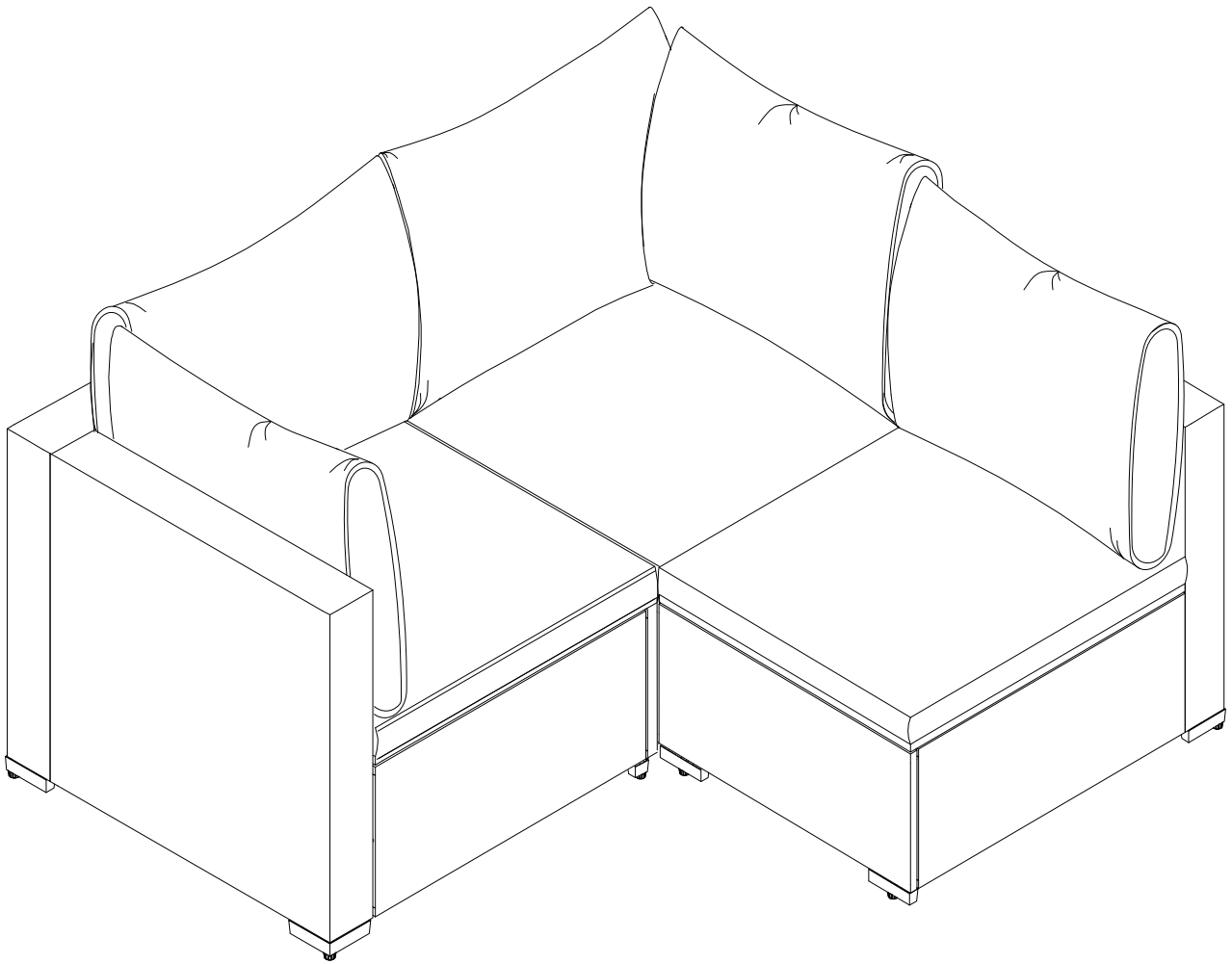

**EN**

## AFTER-SALE SERVICE

If you have any suggestions for our products or notice any quality issues, please contact us first. Our after-sales team will respond within 24 hours and will do everything possible to provide you with a satisfactory solution.

### Guaranteed Customer Service

Your shopping experience is very important to us!

Feel unsatisfied? **Contact us!**

Have any questions? **Contact us!**

Wanna Share how wonderful our smart products make your home?

Share your pictures with us.

Any suggestions? **Contact us!**

We will check and give feedback.



**Patiofurniture Serviceteam@outlook.com**



# Outdoor Fire Table

If you have any questions about the product, please feel free to contact us.

E-Mail: [Patiofurniture Serviceteam@outlook.com](mailto:Patiofurniture Serviceteam@outlook.com)

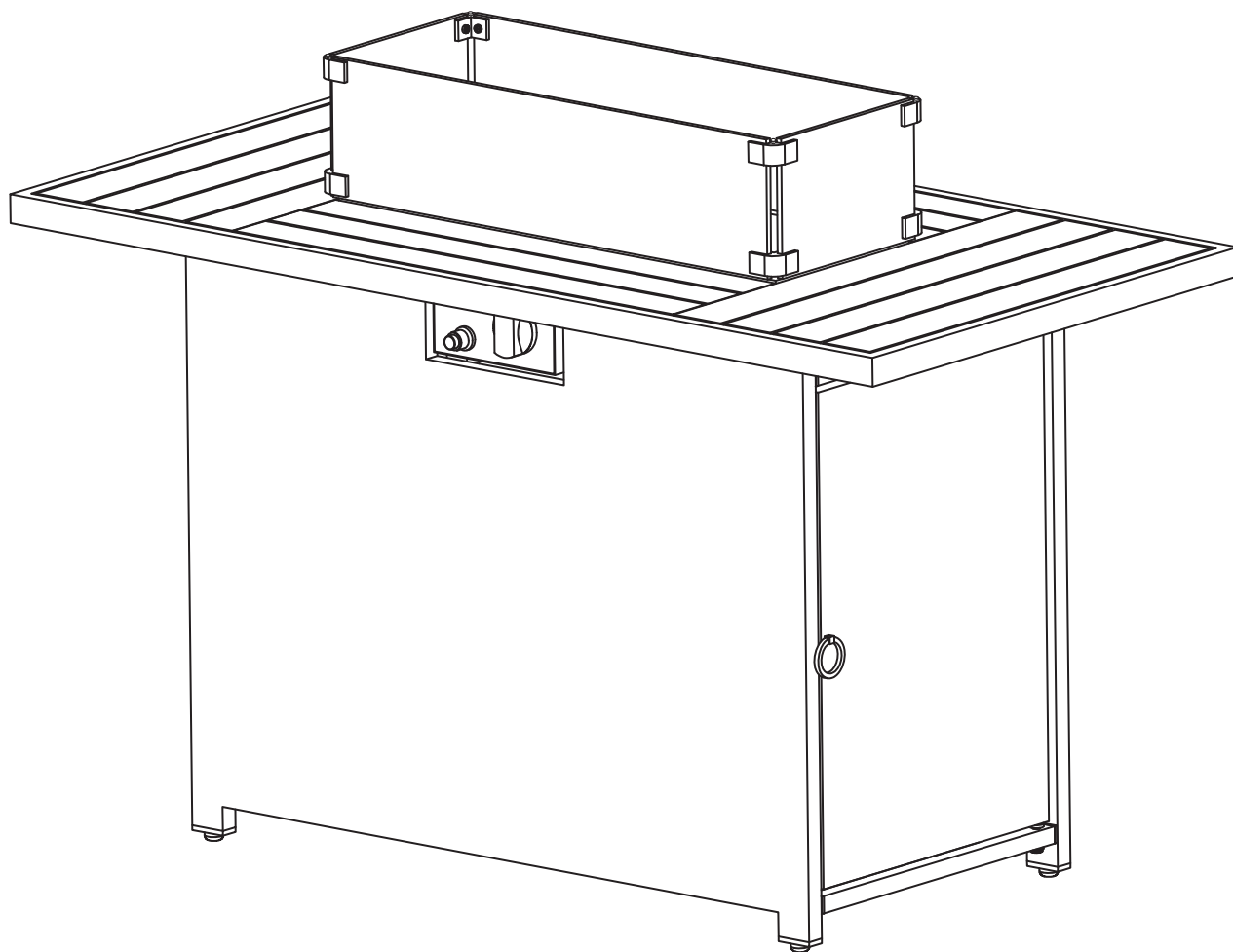

After-sales mailbox:  
[Patiofurniture Serviceteam@outlook.com](mailto:Patiofurniture Serviceteam@outlook.com)

# NOTICE



**Please retain these instructions for future reference.**

**Dear Customer**

● Thank you for your purchase. When you receive the product, please make sure that all the parts are intact. If any parts are missing, please contact us promptly to request replacement parts.

● Then follow the entire installation instructions to install.

● Each part is crucial, so please be careful not to lose any. It is recommended to store parts with different lettered identifiers in separate boxes or bags to avoid confusion during installation.

A . The outer box is damaged

B . The product is damaged / bent / cracked while you open the box

C . The parts / accessories / assembly tools are missing

D . The instructions are not clear and can not be referred

E . The product has functional problems







F . Other aspects that you are not satisfied with

**Please feel free to contact us for help, and provide the following information:**



**Platform/Shop name/Order ID/buyer's name/ receiver's address/Problem description.**

([Patiofurniture Serviceteam@outlook.com](mailto:Patiofurniture Serviceteam@outlook.com)) will reply within 24 hours and will do our best to resolve the problem for you.

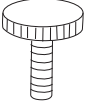
# HARDWARE LIST

<p>①</p>  <p>M6x16</p>	<p>②</p>  <p>M6x30</p>	<p>③</p>  <p>M6x35</p>	<p>④</p>  <p>M6x16</p>	<p>⑤</p>  <p>M6x12x2</p>
<p>12 pc</p>	<p>4 pc</p>	<p>5 pc</p>	<p>21 pc</p>	<p>1 pc</p>
<p>⑥</p>  <p>Cross Wrench</p>	<p>⑦</p> 			
<p>1 pc</p>	<p>4 pc</p>			

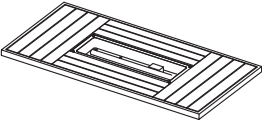
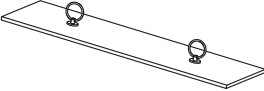
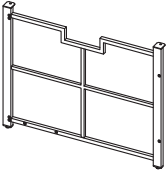
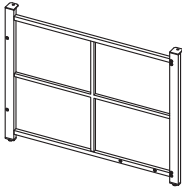

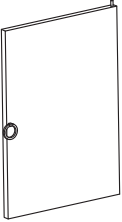
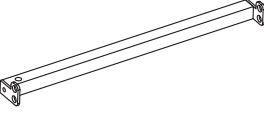
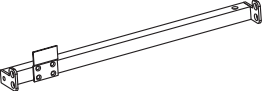
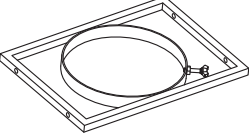
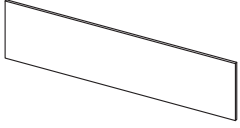
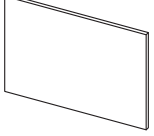
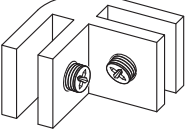
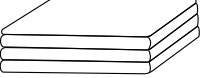
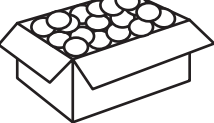

# PART LIST

				
1 pc	1 pc	1 pc	1 pc	1 pc
				
1 pc	1 pc	1 pc	1 pc	2 pcs
				
2 pcs	8 pcs	1 pc	1 pc	

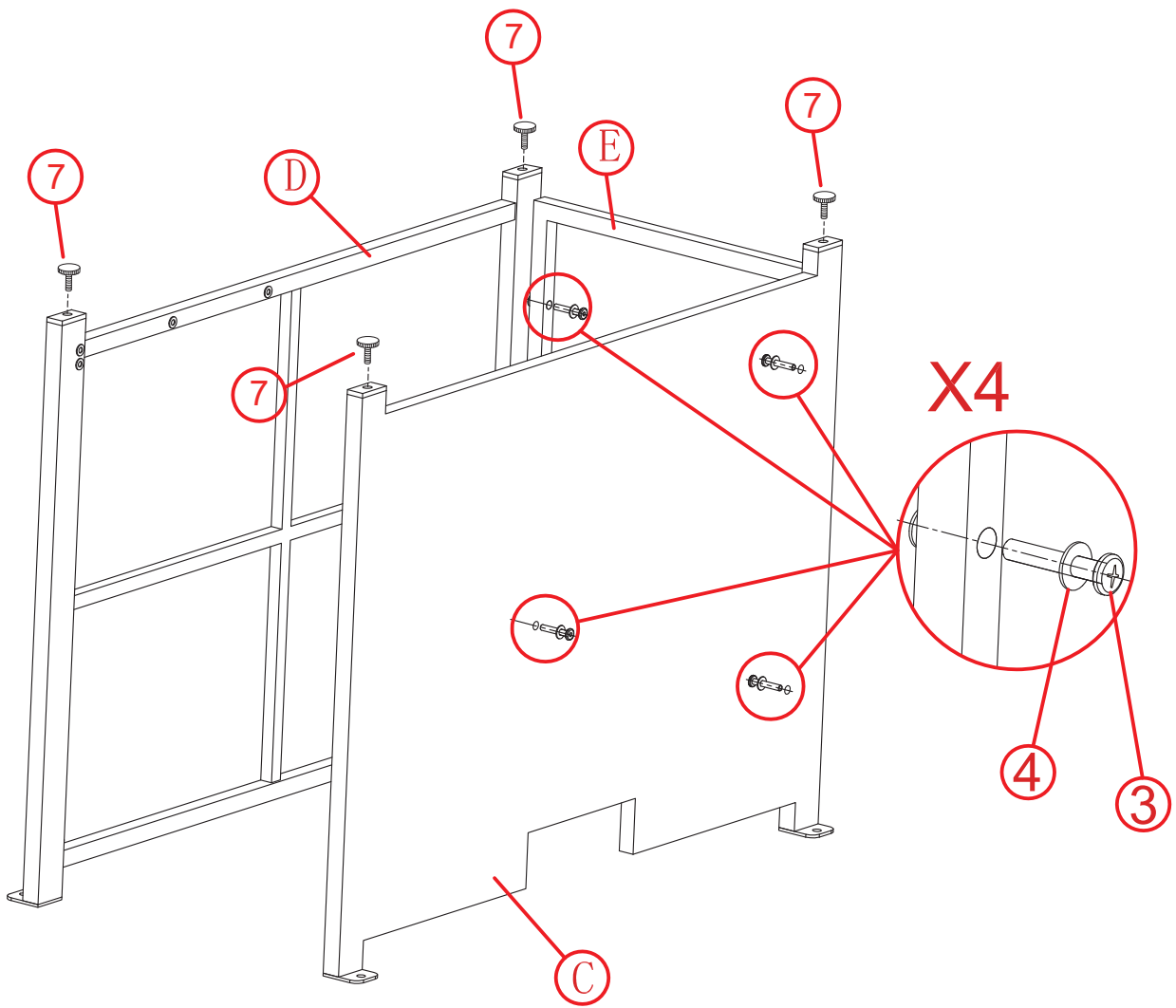
1. Please ensure that all accessories are complete before starting the installation.
  2. Due to the variety of accessories, many accessories may be glued together, please check carefully
  3. If any accessories are missing or damaged, please contact the seller immediately.
- E-Mail: [Patiofurniture Serviceteam@outlook.com](mailto:Patiofurniture Serviceteam@outlook.com)

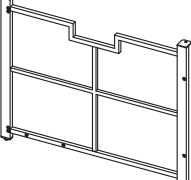
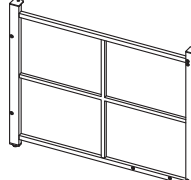
# STEP 1 Frame Structure



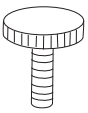

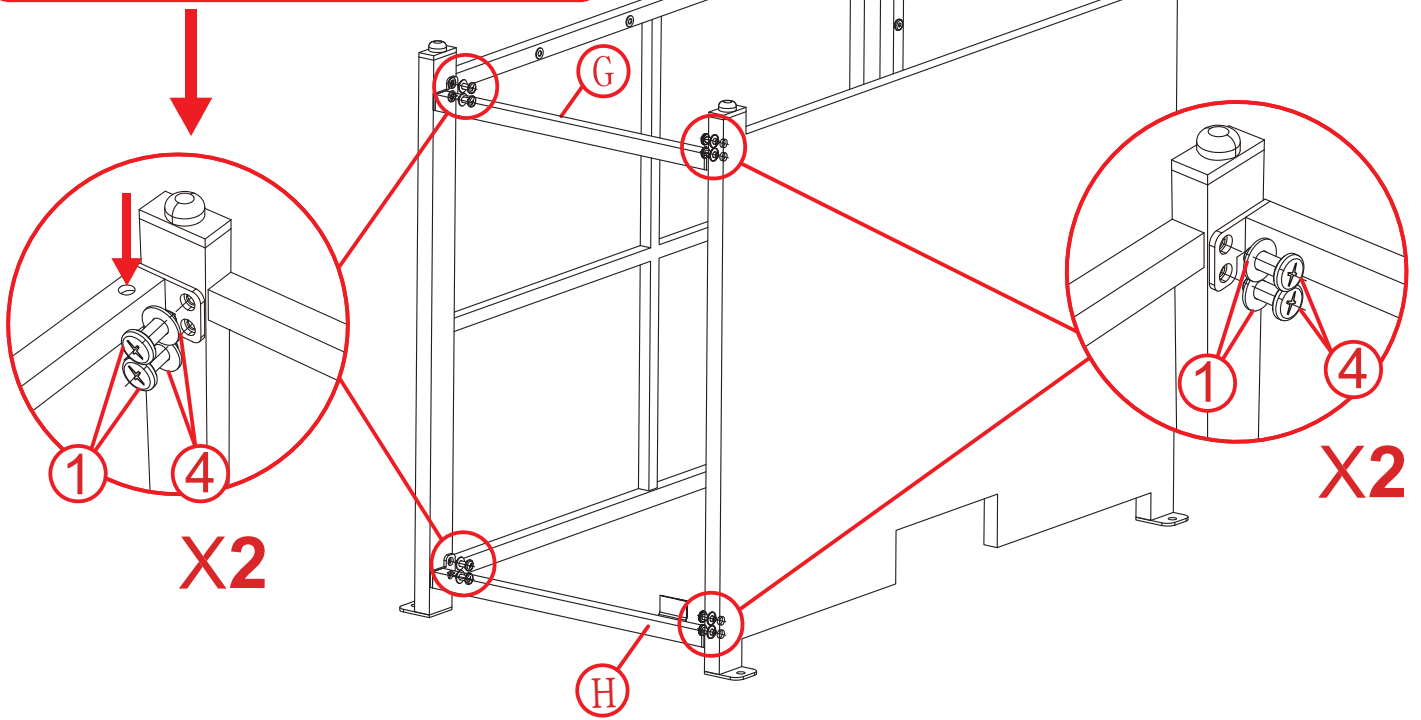

<p>(C)</p> 	<p>(D)</p> 	<p>(E)</p> 	<p>(3)</p> 
<p>1 pc</p>	<p>1 pc</p>	<p>1 pc</p>	<p>4 pc</p>
<p>(4)</p> 	<p>(6)</p>  <p>Cross Wrench</p>	<p>(7)</p> 	
<p>4 pc</p>	<p>1 pc</p>	<p>4 pc</p>	

# STEP 2

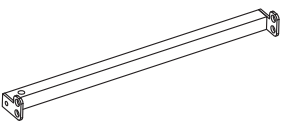
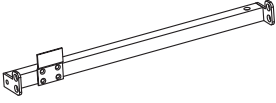



Determine the component installation direction based on the positions of holes.

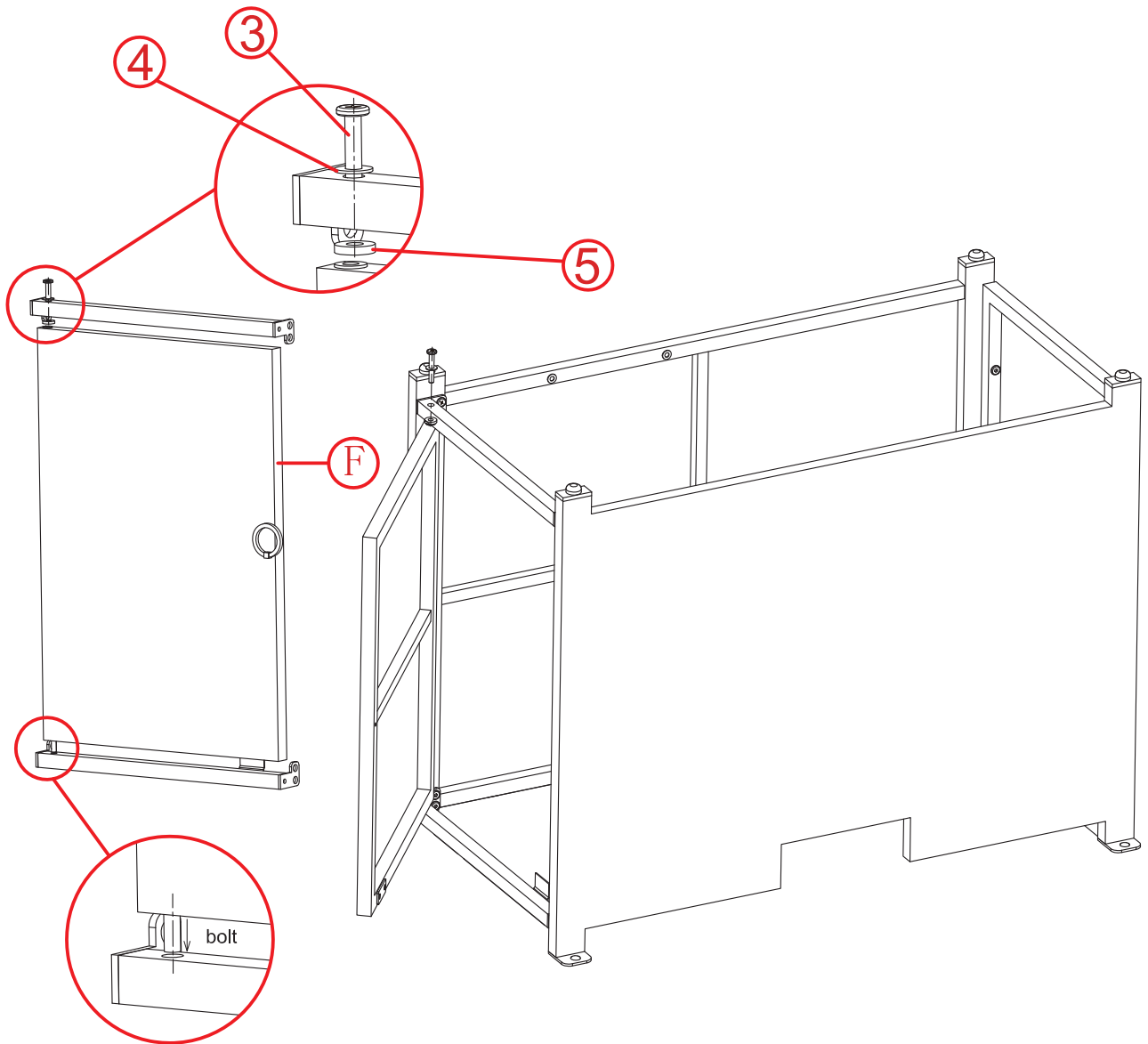

<p>Ⓒ</p> 	<p>Ⓗ</p> 	<p>①</p> 	<p>④</p> 
<p>1 pc</p>	<p>1 pc</p>	<p>8 pc</p>	<p>8 pc</p>
<p>⑥</p>  <p>Cross Wrench</p> <p>1 pc</p>			

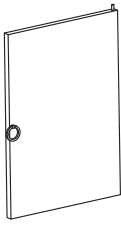



# STEP 3

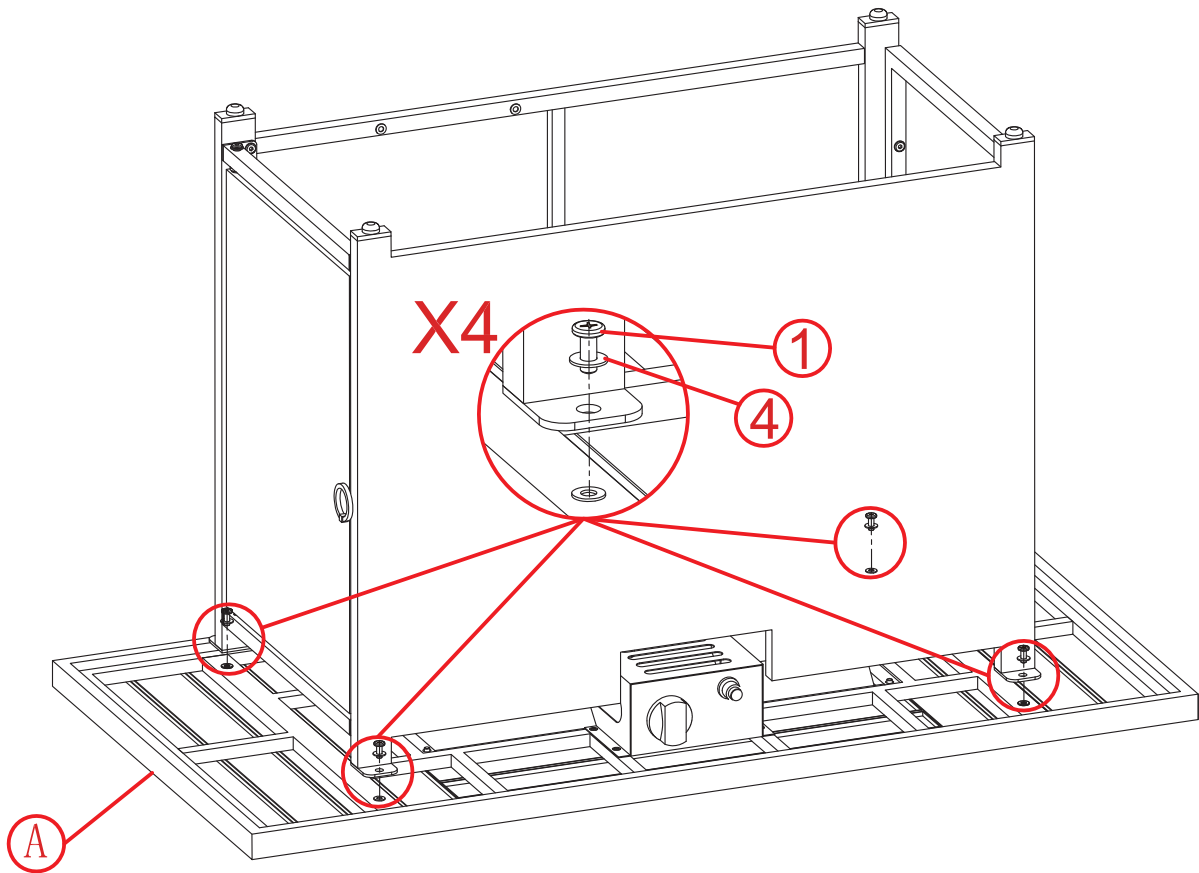

<p>①</p> 	<p>③</p> 	<p>④</p> 	<p>⑤</p> 
<p>1 pc</p>	<p>1 pc</p>	<p>1 pc</p>	<p>1 pc</p>
<p>⑥</p>  <p>Cross Wrench</p> <p>1 pc</p>			

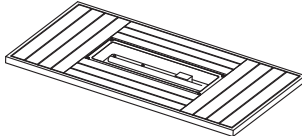

# STEP 4

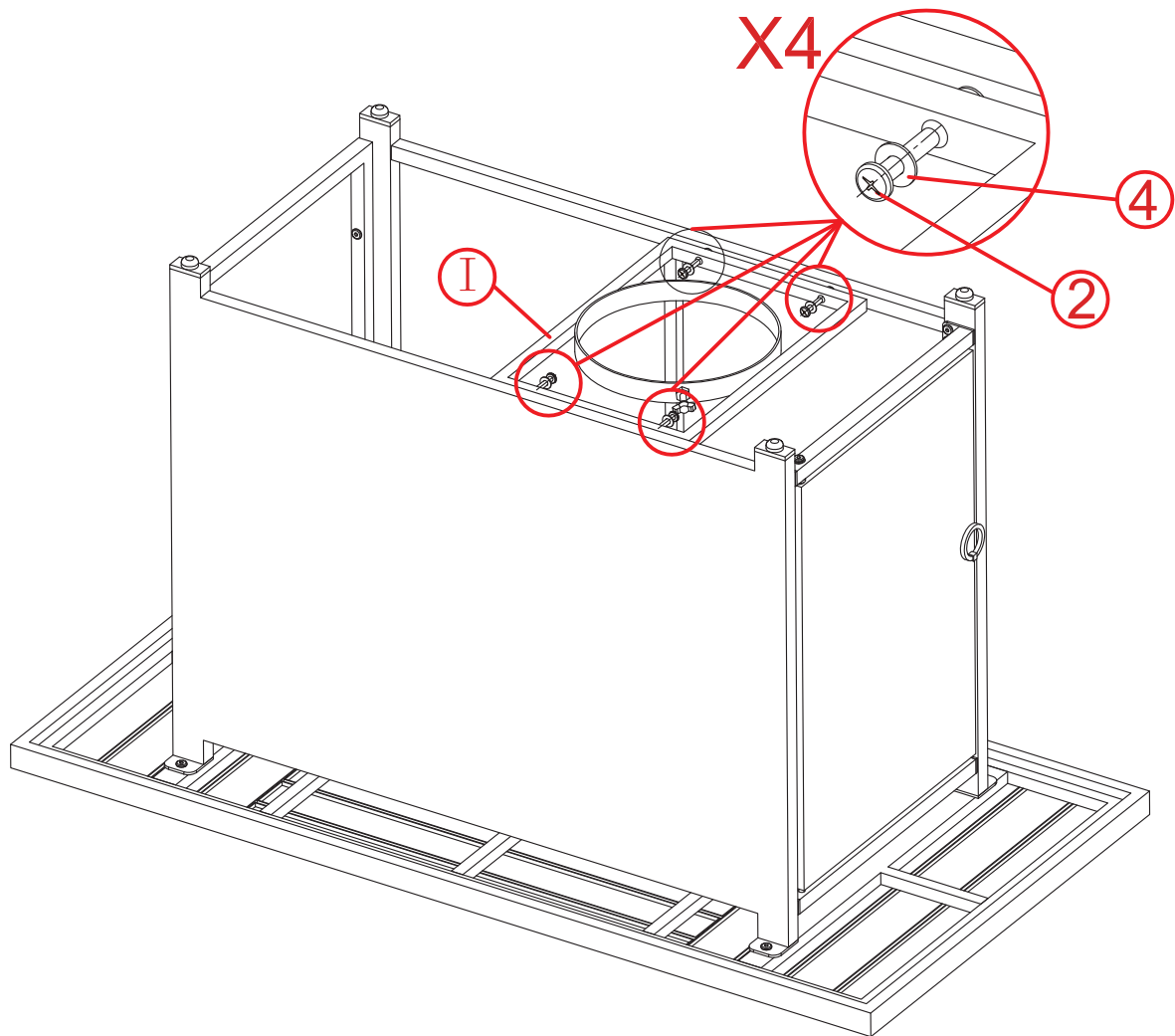

 <p>(A)</p>	 <p>(1)</p>	 <p>(4)</p>	 <p>(6)</p> <p>Cross Wrench</p>
1 pc	4 pc	4 pc	1 pc

# STEP 5

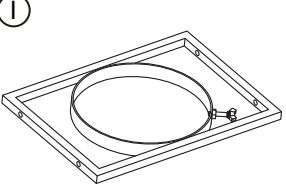

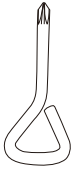
			 Cross Wrench
1 pc	4 pc	4 pc	1 pc

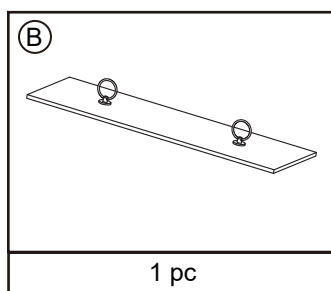
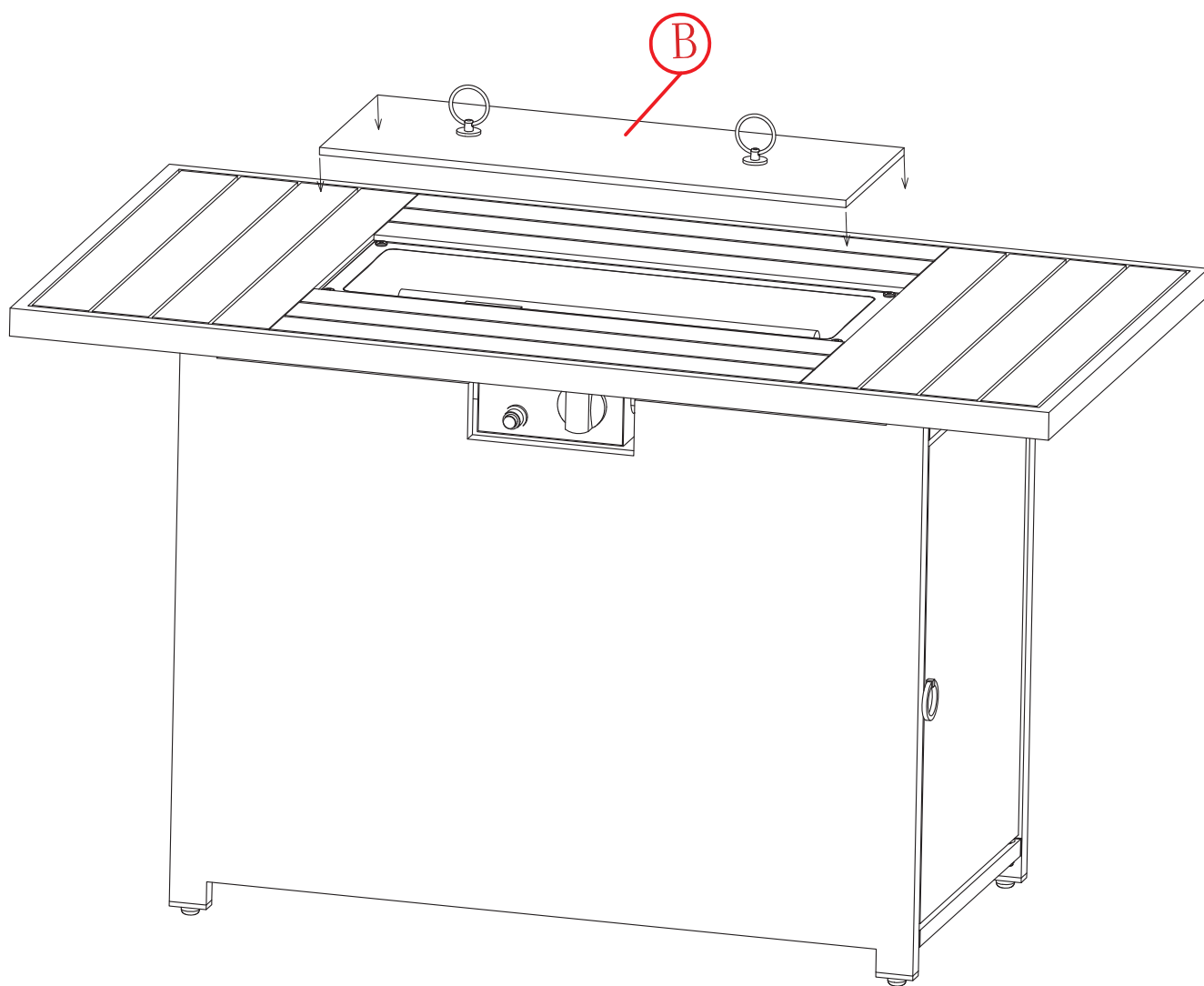

# STEP 6

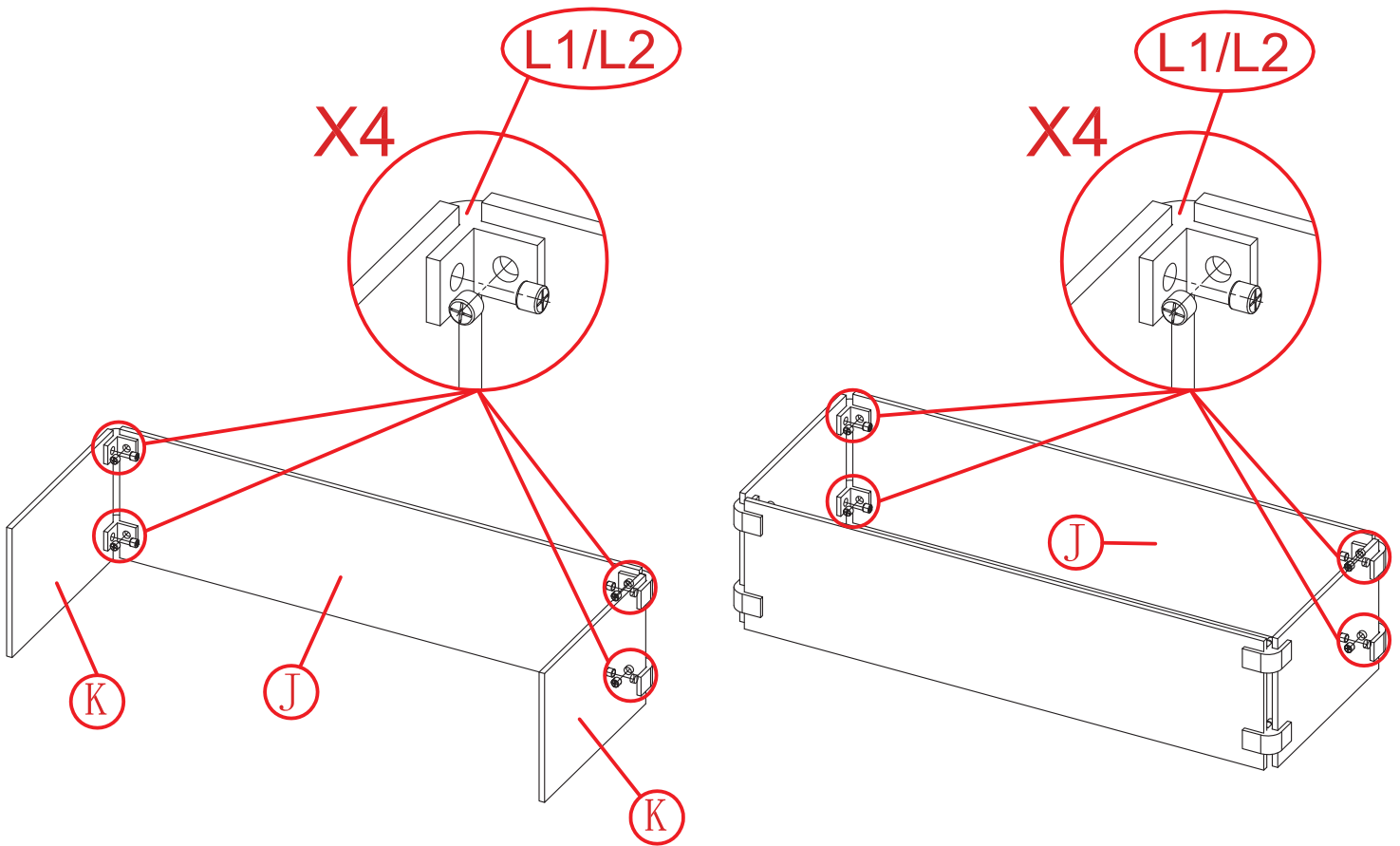

# STEP 7

L2 accessory prevents the glass product from hitting the desk surface.

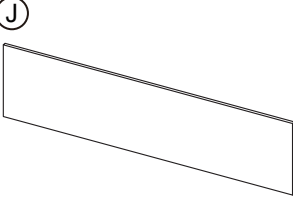
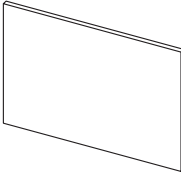
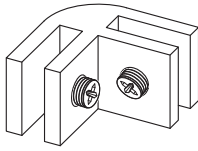
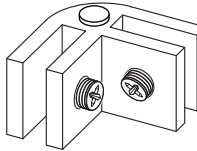

 <p>(J)</p>	 <p>(K)</p>	 <p>(L1)</p>	 <p>(L2)</p>
2 pc	2 pc	4 pc	4 pc
 <p>(6)</p>			
Cross Wrench 1 pc			

## STEP 8

Place a glass cover and cover it with a waterproof cover. There are gaps on both sides of the waterproof cover for ventilation

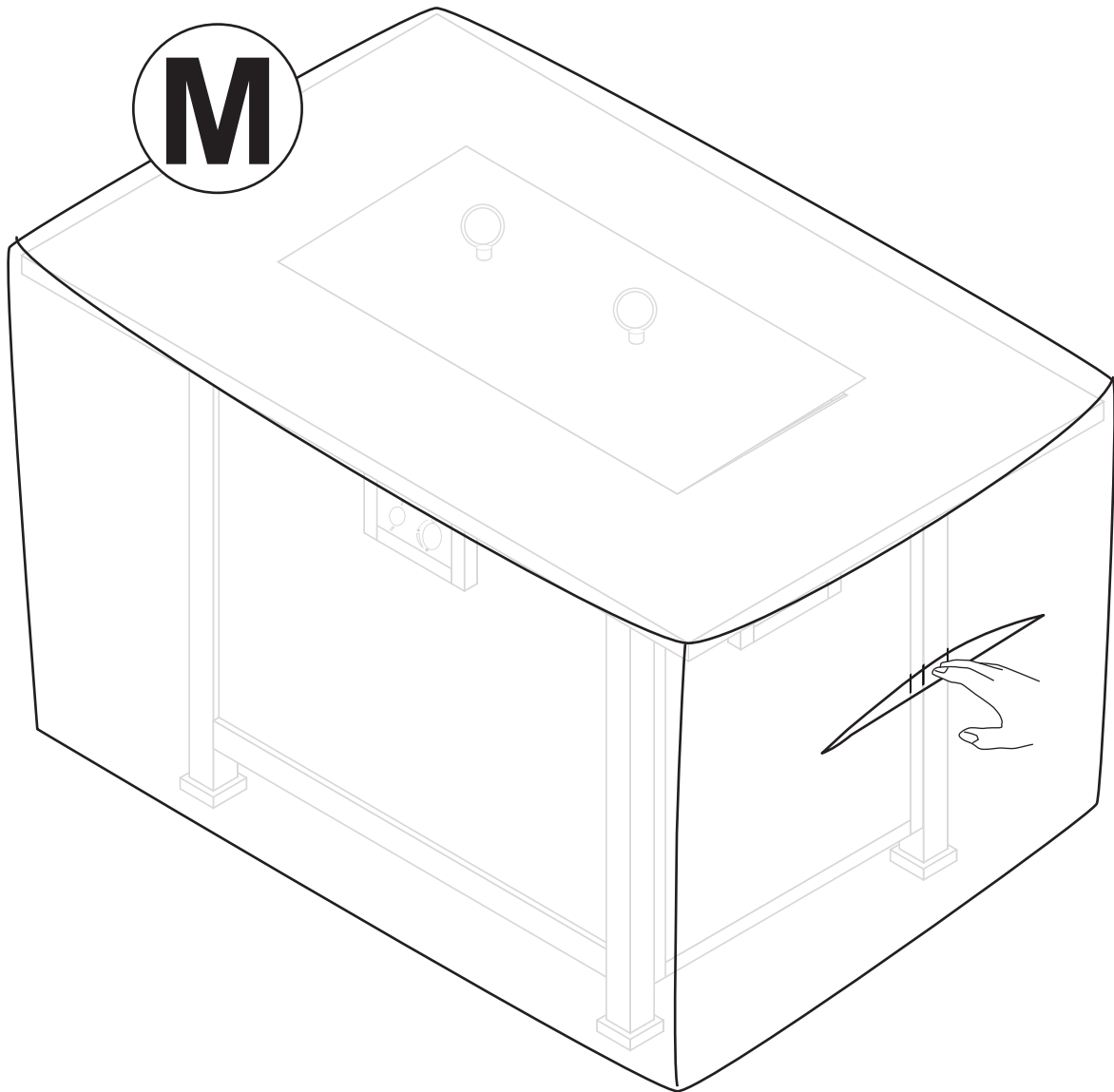

# STEP 9

---

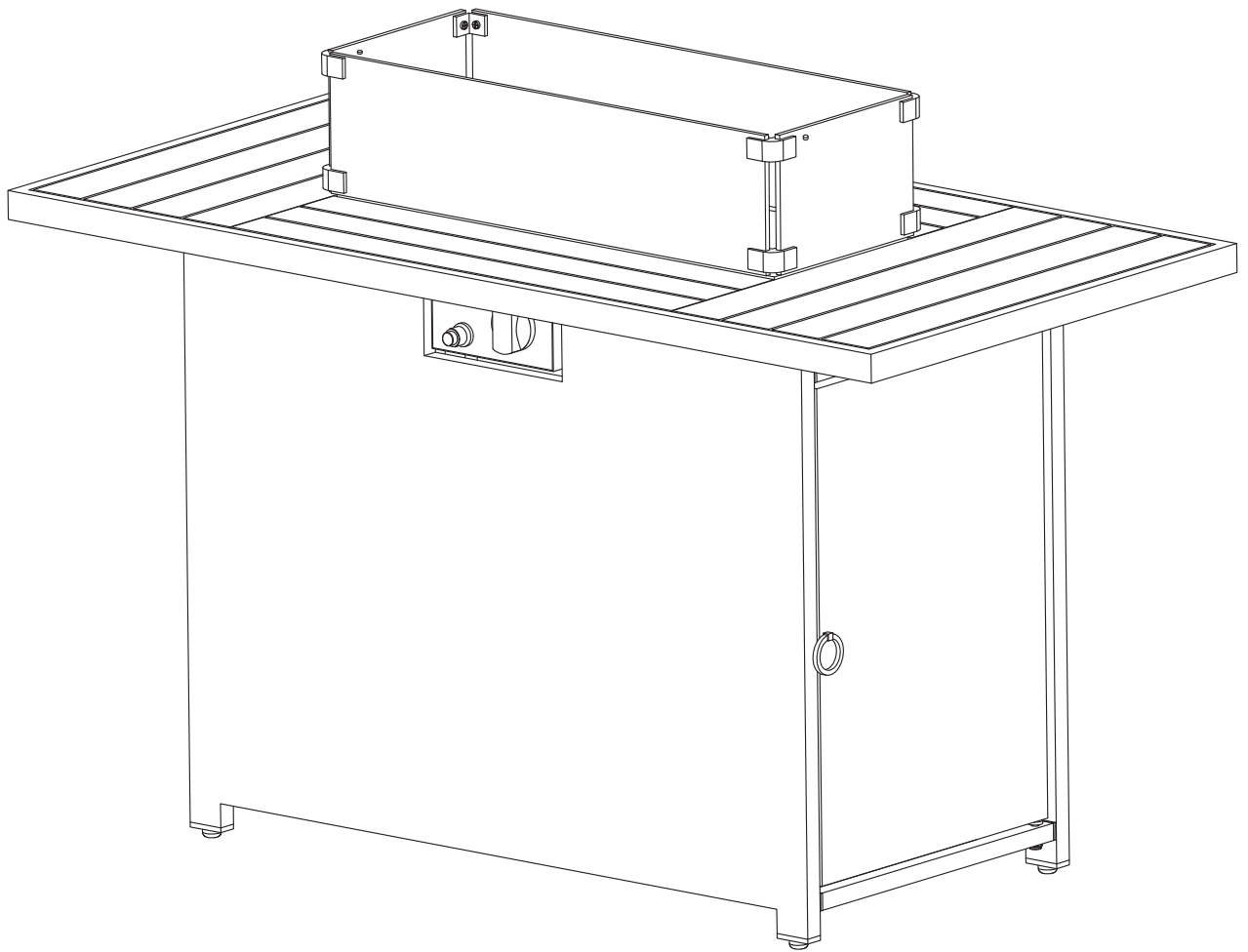

# STEP 10

## LIGHTING INSTRUCTIONS:

1. Read instructions before lighting;
2. Push and turn the knob to LOW;
3. Hold igniter to light the burner,  
release control knob after 15 seconds;  
if burner does not light, wait 5 minutes, repeat;
4. Adjust flame to desired flame with the control knob.

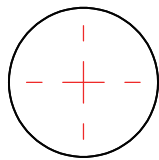

Electronic  
Ignition

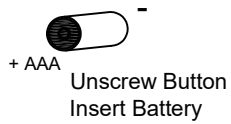

LOW

OFF

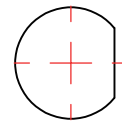

HI

## AFTER-SALE SERVICE CARD

If you have any suggestions for our products or find that the products have quality problems, please contact us first, our after-sales team will reply you within 24 hours, and we will do our best to give you solutions until you are satisfied.

### Guaranteed Customer Service

Your shopping experience is very important to us!  
Feel unsatisfied? **Contact us!**  
Have any questions? **Contact us!**

Wanna Share how wonderful our smart products makes your home?  
Share your pictures with us.  
Any suggestions? **Contact us!**  
We gotcha back!

✉ [Patiofurniture Serviceteam@outlook.com](mailto:Patiofurniture Serviceteam@outlook.com)

