



FORNO

Alta Qualita

FREESTANDING GAS RANGE



INSTALLATION GUIDE

SPECIFICATIONS, INSTALLATION, AND MORE

MODEL NUMBERS:



FFSGS6211-30S



FFSGS6259-30S



FFSGS6228-30S



FFSGS6242-30S

Index

Customer care	1
Warranty	2
Consumer information	4
Anti-tip Device	4
Important Safety information	6
Features of your range	8
Installation instructions	9
Installation Instruction of the Legs	11
Door Handle Installation	12
Installation Instruction of Backsplash	12
Installation Instruction of Kickplate	13
Electrical	13
Gas Supply	14
Product Dimensions and Cabinets	15
Exhaust Hood Installation	18
Gas Conversion Operation	18
Gas Supply Connection	24
Surface Burner Operation	24
Oven Operation	26
Care and Maintenance recommendations	28
Troubleshooting tips	28
Wire Diagram	30

Customer Care

Thank you for purchasing a FORNO product. Please read the entire instruction manual before operating your new appliance for the first time. Whether you are an occasional user or an expert, it will be beneficial to familiarize yourself with the safety practices, features, operation, and care recommendations of your appliance.

Both the model and serial number are listed inside the product. For warranty purposes, you will also need the serial number, the date of purchase & a copy of your proof of purchase. Record this information below for future reference.

SERVICE INFORMATION

Model Number

Use these numbers in any correspondence or service calls concerning your product.

If you receive a damaged product, immediately contact **FORNO**.

Serial Number

Save time and money. Before you call for service, check the Troubleshooting Guide. It lists the causes of minor operating problems that you can correct yourself.

Date of Purchase

Purchase Address & Phone

SERVICE IN CANADA & UNITED STATES

Keep the instruction manual handy to answer your questions. You can also find all the information you need online at www.forno.ca.

If you don't understand something or need more assistance, please visit our website or email: mysupport@forno.ca

If there is a problem, please contact FORNO customer service. Please note that troubleshooting with a customer service representative will be needed before being able to send a service provider. All warranty work needs to be authorized by FORNO customer service. All our authorized service providers are carefully selected and rigorously trained by us.

Warranty

What this limited warranty covers:

The Warranty coverage provided by Forno Appliances in this statement applies exclusively to the original Forno appliance ("Product") sold to the consumer ("Purchaser") by an authorized Forno dealer/distributor/retailer, purchased and installed in the United States or Canada, and which has always remained within the original country of purchase (the United States or Canada). Warranty coverage is activated on the date of the Product's original retail purchase and has a duration of two (2) years.

Warranty coverage is non-transferable. In the event of replacement of parts or of the entire product, the replacement Product (or parts) shall assume the remaining original Warranty activated with the original retail purchase document. This Warranty shall not be extended with respect to such replacement. Forno Appliances will repair or replace any component/part which fails or proves defective due to materials and/or workmanship within 2 years of the date of the original retail purchase and under conditions of ordinary residential, non-commercial use. Repair or replacement will be free of charge, including labor at standard rates and shipping expenses. The purchaser is responsible for making the Product reasonably accessible for service. Repair service must be performed by a Forno Authorized Service company during normal working hours.

IMPORTANT

Retain proof of original purchase to establish warranty period. Forno's liability on any claim of any kind, with respect to the goods and/or services provided, shall in no event exceed the value of the goods or service or part thereof of which has given rise to the claim.

30-Day Cosmetic Warranty

The Purchaser must inspect the product at the time of delivery. Forno warrants that the Product is free from manufacturing defects in materials and workmanship for a period of thirty (30) days from date of the original retail purchase of the Product.

This coverage includes:

- Paint blemishes
- Chips
- Macroscopic finish defects

Cosmetic warranty does NOT cover:

- > issues resulting from incorrect transport, handling and/or installation (e.g.: dents, broken, warped or deformed structures or components, cracked or otherwise damaged glass components);
- > slight color variations on painted/enameled components;
- > differences caused by natural or artificial lighting, location or other analogous factors;
- > stains/corrosion/discoloration caused by external substances and/or environmental factors;
- > labor costs, display, floor, B-stock, out- of-box, "as is" appliances and demo units.

How to receive service

To receive warranty services, the Purchaser must contact the Forno Support department in order to determine the problem and the required service procedures. Troubleshooting with a customer service representative will be necessary before moving forward with the service. Model number, serial number and date of original retail purchase will be requested.

Warranty Exclusions: What Is Not Covered.

- > Use of the Product in any non-residential, commercial application.
- > Use of the Product for anything other than its intended purpose.
- > Repair services provided by anyone other than a Forno Authorized Service agency.
- > Damages or repair services to correct services provided by unauthorized parties or the use of unauthorized parts.
- > Installation not in accordance with local/state/city/county fire codes, electrical codes, gas codes, plumbing codes, building codes, laws or regulations.
- > Defects or damage due to improper storage of the Product.
- > Defects, damage, or missing parts on products sold out of the original factory packaging or from displays.
- > Service calls or repairs to correct an incorrect installation of the Product and/or related accessories.
- > Replacement of parts/service calls to connect, convert or otherwise repair the electrical wiring and/or gas line to properly use the product.
- > Replacement of parts/service calls to provide instructions and information on the use of the Product.
- > Replacement of parts/service calls to correct issues arising from the product being used in a manner other than what is normal and customary for residential use.
- > Replacement of parts/service calls due to wear and tear of components such as seals, knobs, pan supports, shelving, cutlery baskets, buttons, touch displays, scratched or broken ceramic-glass tops.
- > Replacement of parts/service calls for lack of/improper maintenance, including but not limited to: buildup of residues, stains, scratches, discoloration, corrosion.
- > Defects and damages arising from accidents, alteration, misuse, abuse, or improper installation.
- > Defects and damages arising from Product transport, logistics and handling. An inspection of the product must be made at the time of delivery. Following receipt and inspection, the selling dealer/delivery company must be notified of any issues arising from handling, transport, and logistics.
- > Defects and damages arising from external forces beyond the control of Forno Appliances, including but not limited to wind, rain, sand, fires, floods, mudslides, freezing temperatures, excessive moisture or extended exposure to humidity, power surges, lightning, structural failures surrounding the appliance and other acts of God.
- > Products whose serial number has been altered/damaged/tampered with. In no case shall Forno be held liable or responsible for damage to surrounding property, including furniture, cabinetry, flooring, panels, and other structures surrounding the Product. Forno is neither liable nor responsible for the Product if it is in a remote area or an area where certified trained technicians are not reasonably available. Purchaser must bear any transportation and delivery costs of the Product to the nearest Authorized Service Center or the additional travel expenses of a certified trained technician

THERE ARE NO EXPRESS WARRANTIES OTHER THAN THOSE LISTED AND DESCRIBED ABOVE, AND NO WARRANTIES, EITHER EXPRESS OR IMPLIED, INCLUDING, BUT NOT LIMITED TO, ANY IMPLIED WARRANTIES OF MERCHANTABILITY OR FITNESS FOR A PARTICULAR PURPOSE THAT SHALL APPLY AFTER THE EXPRESS WARRANTY PERIODS STATED ABOVE, AND NO OTHER EXPRESS WARRANTY OR GUARANTEE GIVEN BY ANY PERSON, FIRM OR CORPORATION WITH RESPECT TO THIS PRODUCT SHALL BE BINDING ON FORNO. FORNO SHALL NOT BE LIABLE FOR LOSS OF REVENUE OR PROFITS, FAILURE TO REALIZE SAVINGS OR OTHER BENEFITS, TIME AWAY FROM WORK, MEALS, LOSS OF FOOD OR BEVERAGES, TRAVELING OR HOTEL EXPENSES, EXPENSES TO RENT OR PURCHASE APPLIANCES, REMODELING/CONSTRUCTION EXPENSES IN EXCESS OF DIRECT DAMAGES WHICH ARE UNDENIABLY CAUSED EXCLUSIVELY BY FORNO OR ANY OTHER SPECIAL, INCIDENTAL OR CONSEQUENTIAL DAMAGES CAUSED BY THE USE, MISUSE OR INABILITY TO USE THIS PRODUCT, REGARDLESS OF THE LEGAL THEORY ON WHICH THE CLAIM IS BASED, AND EVEN IF FORNO HAS BEEN ADVISED OF THE POSSIBILITY OF SUCH DAMAGES. NOR SHALL RECOVERY OF ANY KIND AGAINST FORNO BE GREATER IN AMOUNT THAN THE PURCHASE PRICE OF THE PRODUCT SOLD BY FORNO AND CAUSING THE ALLEGED DAMAGE. WITHOUT PREJUDICE TO THE FOREGOING, PURCHASER ASSUMES ALL RISK AND LIABILITY FOR LOSS, DAMAGE OR INJURY TO PURCHASER AND PURCHASER'S PROPERTY AND TO OTHERS AND THEIR PROPERTY ARISING FROM THE USE, MISUSE, OR INABILITY TO USE THIS PRODUCT SOLD BY FORNO THAT IS NOT A DIRECT RESULT OF NEGLIGENCE ON THE PART OF FORNO THIS LIMITED WARRANTY SHALL NOT EXTEND TO ANYONE OTHER THAN THE ORIGINAL PURCHASER OF THIS PRODUCT, IS NON-TRANSFERABLE, AND STATES YOUR EXCLUSIVE REMEDY.

Consumer information

Range Safety

Your safety and the safety of others are very important.

We have provided many important safety messages in this manual and on your appliance. Always read and obey all safety messages.



This is a safety alert symbol. It will alert you to potential personal or property safety hazards. Obey all safety messages to avoid any property damage, personal injury, or death.

⚠️WARNING

WARNING indicates a potentially hazardous situation which, if not avoided, could result in serious injury or death.

⚠️CAUTION

CAUTION indicates a moderate hazardous situation which, if not avoided, could result in minor or moderate injury.

All safety messages will alert you of what the potential hazard is, tell you how to reduce the chance of injury, and let you know what can happen if the instructions are not followed.

⚠️WARNING

If the information in this manual is not followed exactly, a fire or explosion may result, causing property damage, personal injury or death.

Do not store or use gasoline or other flammable vapors and liquids in the vicinity of this or any other appliance.

- WHAT TO DO IF YOU SMELL GAS

- Do not try to light any appliance.
- Do not touch any electrical switch.
- Do not use any phone in your building.
- Immediately call your gas supplier from a neighbor's phone. Follow the gas supplier's instructions.
- If you cannot reach your gas supplier, call the fire department.

Installation and service must be performed by a qualified installer, service agency or the gas supplier.

ANTI-TIP DEVICE



⚠️WARNING Tip-over Hazard

A Child or adult can tip the range which can result in serious injuries or death.

Install the anti-tip device to the range and/or structure per installation instructions.

Engage the range to the Anti-tip device installed to the structure.

Re-engage the anti-tip device if the range is removed.

Failure to follow these instructions can result in death or serious injuries and/or burns to children and adults.

To reduce the risk of tipping the range, the range must be secured by properly installed anti-tip device packed with the range. All ranges can tip and cause injuries.

Make sure the anti-tip device is installed.

Options 1 for the anti-tip device:

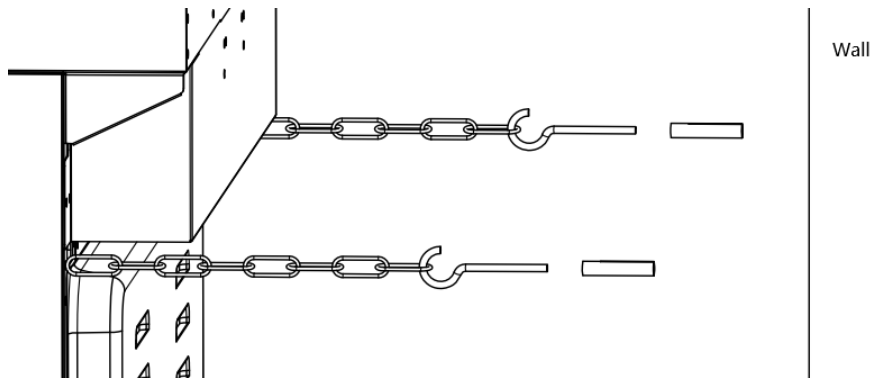

- 1) Check if one side of the anti-tip chain has installed well on the range.
- 2) Drill 1 hole for both sides to fix the end of the chains securely to the wall according to the above drawing.
- 3) Slide in the cooking range towards the anti-tip bracket. Check to make sure it is properly installed.

Options 2 for the anti-tip device:

182.5mm
7.2"

352mm
13.9"

Move Range Back

696mm to 746mm
27.4" to 29.4"

Range Side

3) After setting the positions of anti-tip bracket, drill 3 holes on each side, insert the expansion screws and M4*30 screws to fix bracket to wall securely.

4) After finishing the installation for bracket, Move Range Back to the wall, and let the anti-tip bracket insert to the vacancy that back of the Range as drawing.

- 1) Find the anti-tip bracket(2 pieces) and M4*30 screws & expansion screws(6 pieces) from the accessories box.
- 2) Please refer to above drawing to settle the position for anti-tip bracket. Minimum height & Maximum height of anti-tip bracket can be 27.4"(696mm) to 29.4"(746mm), the height varies depending on the final height of the range setting. Mark the position you set with pencil.

⚠️ WARNING

This product can expose you to chemicals including carbon monoxide, which is known to the State of California to cause developmental harm. For more information go to www.P65Warnings.ca.gov.

To minimize exposure to these substances. Always operate this unit according to the Instruction Manual and ensure that you provide proper ventilation.

The installation must conform with local codes or, in the absence of local codes, with the National Fuel Gas Code, ANSI Z223.1/NFPA 54 or, in Canada, the Natural Gas and Propane Installation Code, CSA B149.1.

⚠️WARNING

Never operate the top surface cooking section of the appliance unattended. Failure to follow this warning statement may result in fire, explosion or burn hazard that could cause property damage, personal injury, or death. If a fire should occur, keep away from the appliance and immediately call your fire department.

DO NOT ATTEMPT TO EXTINGUISH AN OIL/GREASE FIRE WITH WATER.

IMPORTANT SAFETY INFORMATION

READ ALL INSTRUCTIONS BEFORE USING THE APPLIANCE

⚠️WARNING

Read all safety instructions before using the product. Failure to follow these instructions may result in fire, electrical shock, serious injury or death.

GENERAL SAFETY INSTRUCTIONS

⚠️WARNING

NEVER use this appliance as a space heater to heat or warm the room. Doing so may result in carbon monoxide poisoning and overheating of the oven.

1. Use this range for its intended purpose as described in this instruction manual.
2. Have your range installed and properly grounded by a qualified installer in accordance with the provided installation instructions.
3. Any adjustment and service should be performed only by a qualified gas range installer or service technician. Do not attempt to repair or replace any part of your range unless it is specifically recommended in this manual.
4. Your range is shipped from the factory set for use with natural gas or propane (LP) gas. It can be converted for use with either. If required, these adjustments must be made by a qualified technician in accordance with the installation instructions and local codes. The agency performing this work assumes responsibility for the conversion.
5. Have the installer show you the location of the range gas shut-off valve and how to turn it off if necessary.
6. Plug your range into a 120-volt grounded outlet only. Do not remove the round grounding prong from the plug. If in doubt about the grounding of the home electrical system, it is your responsibility and obligation to have an ungrounded outlet in accordance with the National Electrical Code. Do not use an extension code with this range.
7. Before performing any service, unplug the range or disconnect the power supply from the household distribution panel by removing the fuse or switching off the circuit breaker.
8. Be sure all packing materials are removed from the range before operating to prevent ignition of these materials.
9. Avoid scratching or impacting glass displays. Doing so may lead to glass breakage. Do not cook on a product with broken glass. Shock, fire, or cuts may occur.
10. Do not leave children alone or unattended in an area where an appliance is in use. They should never be allowed to climb, sit or stand on any part of the range.

⚠️CAUTION

11. Do not store items of interest to children in cabinets above an oven-children who climb onto the oven to reach items could be seriously injured.
12. Never block the vents (air openings) of the range. They provide the air inlets and outlets that are necessary for the range to operate properly with correct combustion. Air openings are located at the rear of the cooktop, at the top and bottom of the oven door, and at the bottom of the range.
13. Use only dry potholders--moist or damp potholders on hot surfaces may result in burns from steam. Do not let potholders touch surface burners, burner grate, or oven heating element. Do not use a towel or other bulky fabrics in place of potholders.
14. Do not touch the heating elements or the interior surface of the oven. These surfaces may be hot enough to burn even though they are dark in color. During and after use, do not touch, or let clothing or other flammable materials contact any interior area of the oven; allow sufficient time for cooling first. Other surfaces of the appliance may become hot enough to cause burns. Potentially hot surfaces include the burners, grates, oven vent opening, surfaces near the opening, crevices around the oven door, metal trim parts above the door, any back guard, or high shelf surface.
15. Do not heat unopened food containers. Pressure could build up and the container could burst, causing any injury.

⚠️WARNING Extremely Heavy.

Proper equipment and adequate manpower are needed when move the range to avoid personal injury or damage to the unit or the floor. Failure to follow this advice may result in damage or personal injury.

⚠️WARNING DO NOT carry or lift the cooking range by the oven door handle or the control panel!

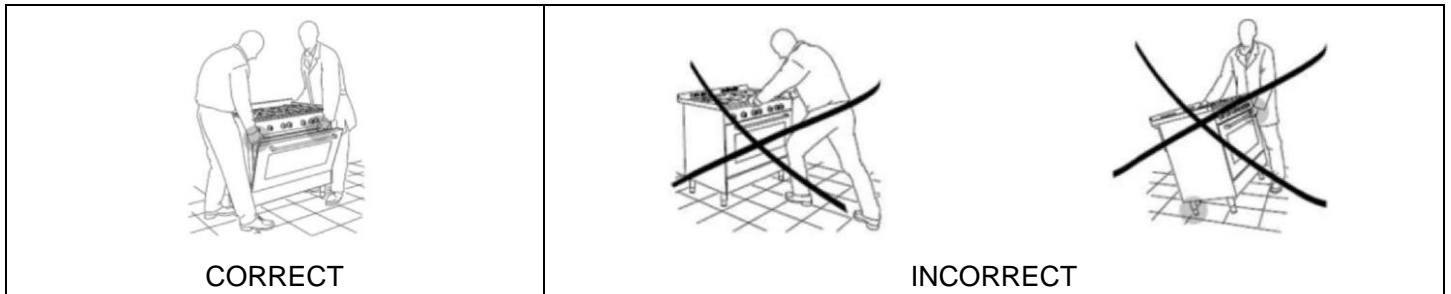

⚠️WARNING GENERAL SAFETY INSTRUCTIONS

Cook food thoroughly to help protect against foodborne illness. Minimum safe food temperature recommendations can be found at www.IsItDoneYet.gov and www.fsis.usda.gov. Use a food thermometer to take food temperatures and check several locations.

Do not allow anyone to climb, stand or hang on the oven door, drawer, or cooktop. They could damage the range or tip it over causing severe injury or death.

Keep the ventilator hood and grease filter clean to maintain good venting and to avoid grease fires. Turn the ventilator OFF in case of a fire or when intentionally "flaming" liquor or other spirits on the cooktop. The blower, if in operation, could spread the flames.

⚠️WARNING KEEP FLAMMABLE MATERIAL AWAY FROM THE RANGE Failure to do so may result in fire or personal injury.

Do not store or use flammable materials in an oven or near the cooktop, including paper, plastic, potholders, linens, wall coverings, curtains, drapes and gasoline or other flammable vapors and liquids.

Never wear loose-fitting or hanging garments while using the appliance. These garments may ignite if they contact hot surfaces causing severe burns.

Do not let cooking grease or other flammable materials accumulate in or near the range.
Grease in the oven or on the cooktop may ignite.

⚠️WARNING IN THE EVENT OF A FIRE, TAKE THE FOLLOWING STEP TO PREVENT INJURY AND FIRE SPREADING.

Do not use water on grease fires. Never pick up a flaming pan. Turn the controls off. Smother a flaming pan on a surface unit by covering the pan completely with a well-fitting lid, cookie sheet or flat tray. Use a multi-purpose dry chemical or foam-type fire extinguisher.

If there is a fire in the oven during baking, smother the fire by closing the oven door and turning the oven off or by using a multi-purpose dry chemical or foam-type fire extinguisher.

If there is a fire in the oven during self-clean, turn the oven off and wait for the fire to go out.

Do not force the door open. Introduction of fresh air at self-clean temperatures may lead to a burst of flame from the oven. Failure to follow this instruction may result in severe burns.

⚠️WARNING COOKTOP SAFETY INSTRUCTIONS

Never leave the surface burners unattended at medium or high heat settings. Foods, especially oily foods, may ignite resulting in fire that could spread to surrounding cabinets.

Never leave oil unattended while frying. If allowed to heat beyond its smoking point, oil may ignite resulting in fire that may spread to surrounding cabinets. Use a deep fat thermometer whenever possible to monitor oil temperature.

To avoid oil spillover and fire, use the minimum amount of oil when frying in a shallow pan and avoid cooking frozen foods with excessive amounts of ice.

Use proper pan size and avoid pans that are unstable or easily tipped. Select cookware that matches the size of the burner. Burner flames should be adjusted so that they do not extend beyond the bottom of the pan. Excessive flames may be hazardous.

When using glass/ceramic cookware, make sure it is suitable for cooktop use; others may break because of a sudden change in temperature.

To minimize the possibility of burns, ignition of flammable materials and spillage, cookware handles should be turned toward the center of the range without extending over nearby burners.

Do not use a wok with a round metal support ring. The ring may trap heat and block air to the burner resulting in a carbon monoxide hazard.

Do not attempt to lift the cooktop. Doing so may damage the gas tubing to the surface burners resulting in a gas leak and risk of fire.

Do not use aluminum foil to cover the grills or line any part of the cooktop. Doing so may result in carbon monoxide poisoning, overheating of the cooktop surfaces, or a potential fire hazard.

⚠️ WARNING OVEN SAFETY INSTRUCTIONS

NEVER cover any slots, holes, or passages in the oven bottom or cover an entire rack with materials such as aluminum foil or oven liners. Doing so blocks air flow through the oven and may cause carbon monoxide poisoning. Never place foil or oven liners on the oven bottom. They can trap heat causing the risk of smoke or fire.

Stand away from the range when opening the oven door. Escaping hot air or steam can cause burns to hands, face and/or eyes.

Never place cooking utensils, pizza or baking stones, or any type of foil or liner on the oven floor.

These items can trap heat or melt, resulting in damage to the product and risk of shock, smoke, or fire.

Place oven racks in desired location while oven is cool. If the rack must be moved while the oven is hot, be careful to avoid touching hot surfaces.

Do not leave items such as paper, cooking utensils, or food in the oven when not in use. Items stored in an oven can ignite.

Do not leave items on the cooktop near the oven vent. Items may overheat resulting in a risk of fire or burns.

Never broil with the door open. Open-door broiling is not advised due to overheating of control knobs.

Features of Your Range

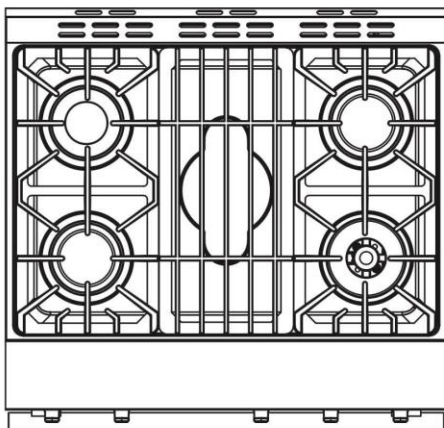

4 burners (FFSGS6228-30S)

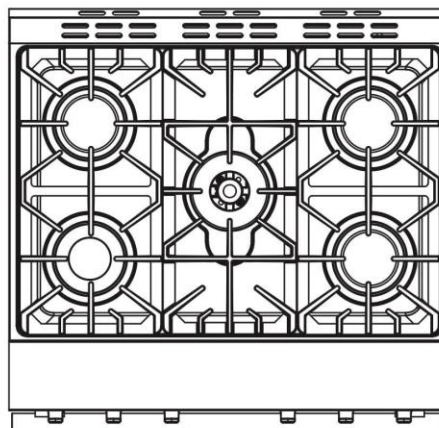

5 burners (FFSGS6242-30S)

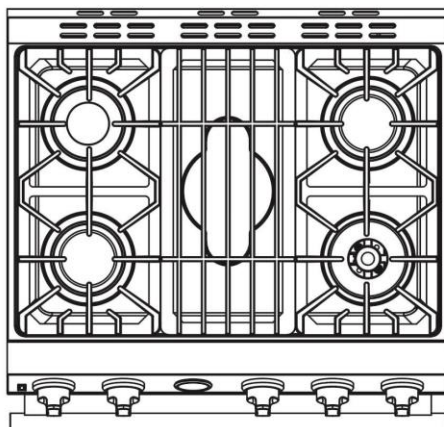

4 burners (FFSGS6211-30S)

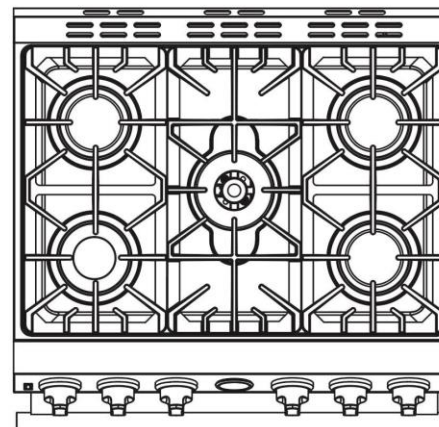

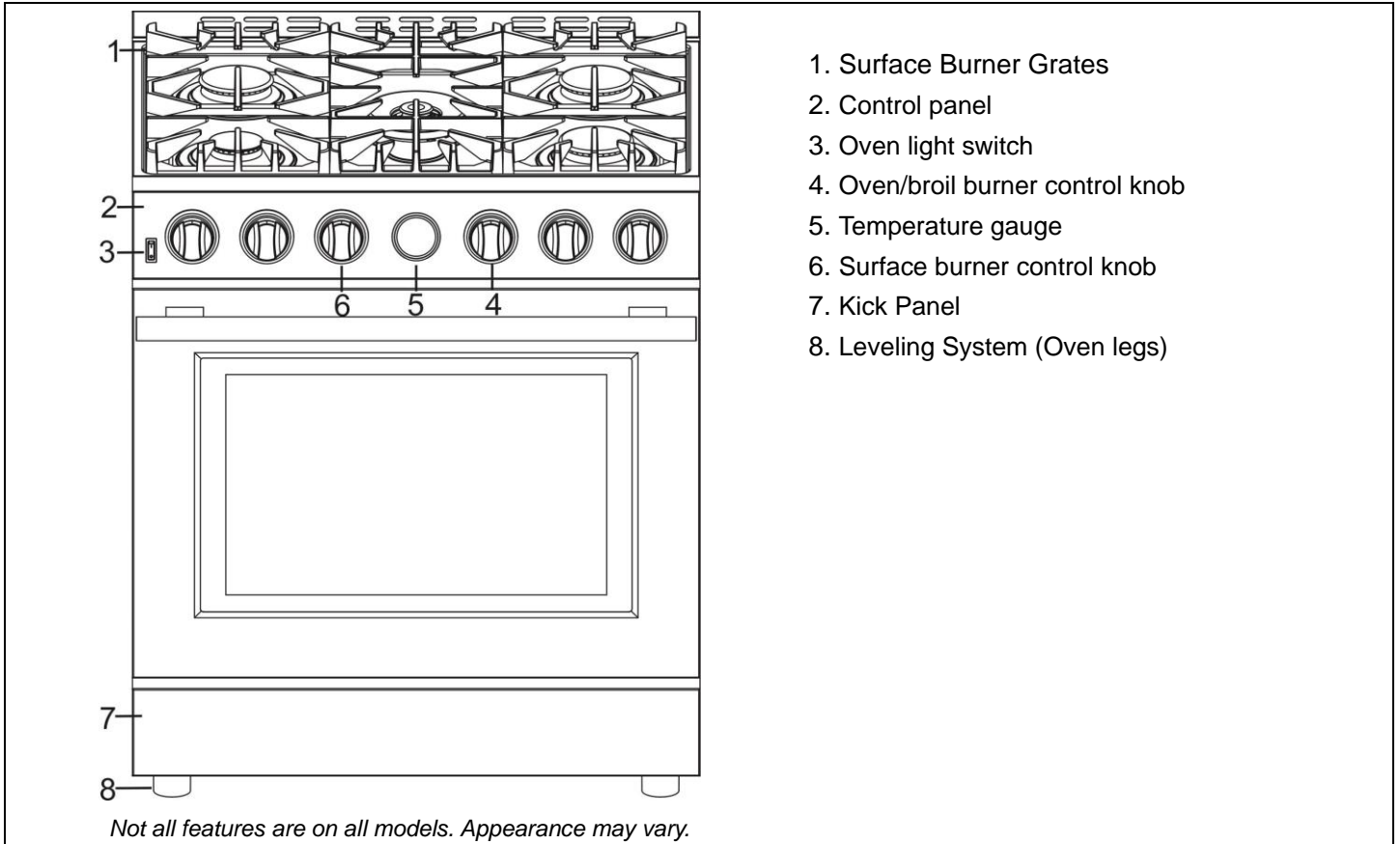

5 burners (FFSGS6259-30S)









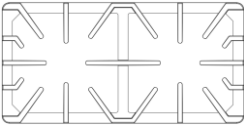
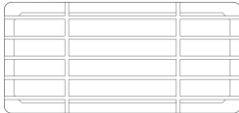

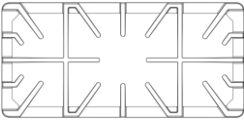
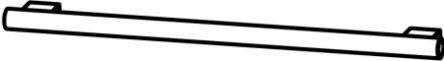
INSTALLATION INSTRUCTIONS

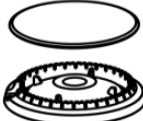

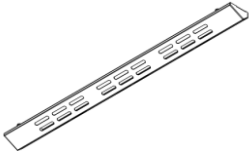
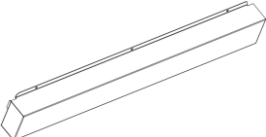

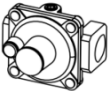





Before using your range

1. Remove all packaging material.
2. Check to make sure you have all the accessories listed below:

	LPG injector	FFSGS6211-30S	7 sets
		FFSGS6228-30S	7 sets
		FFSGS6259-30S	8 sets
		FFSGS6242-30S	8 sets
	Anti-tip chain (pre-installed)		1 set
	Anti-tip bracket and screws		1 set
	Burner grills	FFSGS6211-30S	2 pieces
		FFSGS6228-30S	2 pieces
		FFSGS6259-30S	2 pieces
		FFSGS6242-30S	2 pieces
	Burner grill (Middle) (for FFSGS6211-30S and FFSGS6228-30S)		1 piece

	Burner grill (Middle) (for FFSGS6259-30S and FFSGS6242-30S)	1 piece	
	Oven door handle	1 piece	
	Burner & Cap (5000BTU)	FFSGS6211-30S	1 set
		FFSGS6228-30S	1 set
		FFSGS6259-30S	1 set
		FFSGS6242-30S	1 set
	Burner & Cap (9000BTU)	FFSGS6211-30S	2 set
		FFSGS6228-30S	2 set
		FFSGS6259-30S	3 sets
		FFSGS6242-30S	3 sets
	Burner & Cap (18000BTU)	FFSGS6211-30S	1 set
		FFSGS6228-30S	1 set
		FFSGS6259-30S	1 set
		FFSGS6242-30S	1 set
	Baking rack	2 pieces	
	Backsplash	1 piece	
	Kick Plate	1 piece	
	Leg	4 pieces	
	Regulator (pre-installed)	1 piece	
	Serial Number Sticker & Instruction Manual	1 set	

TOOLS NEEDED FOR INSTALLATION (not supplied with the range)

 Screwdriver	 Wrench	 Socket wrench	 Allen key	 Tape measure &Pencil
 Protective gloves	 Hammer	 Adjustable wrench	 Adjustable pliers	 Drill

Installation Instruction of the Legs

The ranges must be used only with the legs properly installed. Four height-adjustable legs are shipped with the range situated in the oven cavity. Before installing the legs, position the appliance near its final location as the legs are not suitable for moving the appliance over long distances.

After unpacking the range, raise it enough to insert the legs in the appropriate receptacles situated on the lower part of the appliance.

Lower the range gently to keep any undue strain from legs and mounting hardware. If possible, use a pallet or lift jack instead of tilting the unit.

Adjust leg height to the desired level by twisting the inside portion of the leg assembly until the proper height is reached. Check with a level that the cooktop is perfectly level.

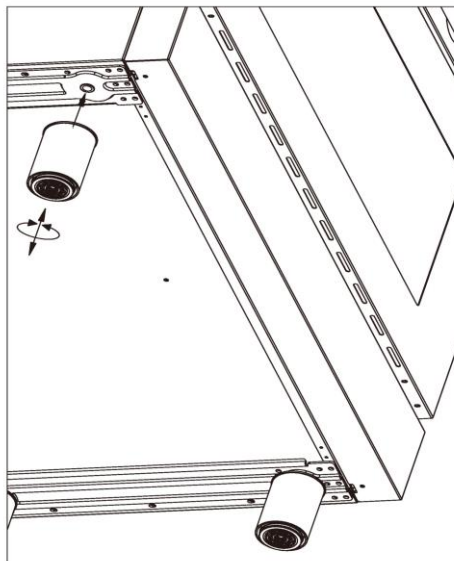

Door Handle Installation

The door handle is not pre-installed. Follow the illustrations below to install the door handle quickly and easily.

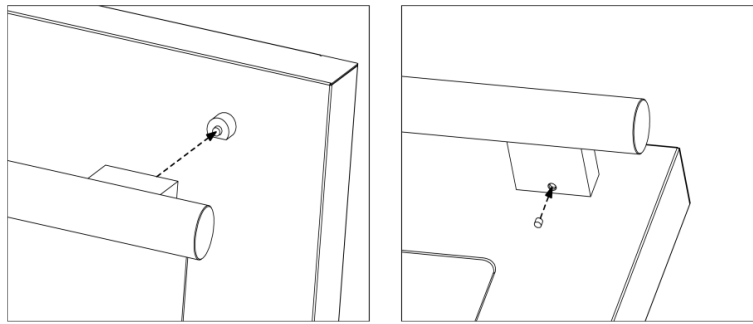

Step 1. Put the handle cover the nut on the door, let the nut insert to the handle base.

Step 2. Tighten the bolt bottom.

Step 3. Repeat Step 1 to 2 for the other side. Make sure tighten the bolt for both sides.

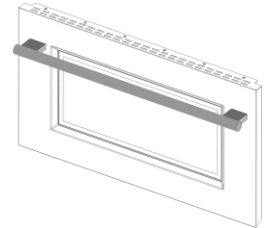

Installation Instruction of Backsplash

Take out the backsplash from the parts box on the back. Follow the instructions below to install the backsplash.

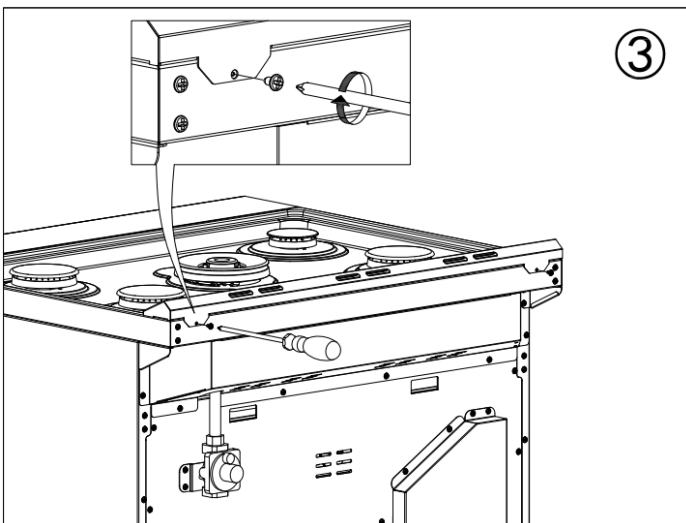
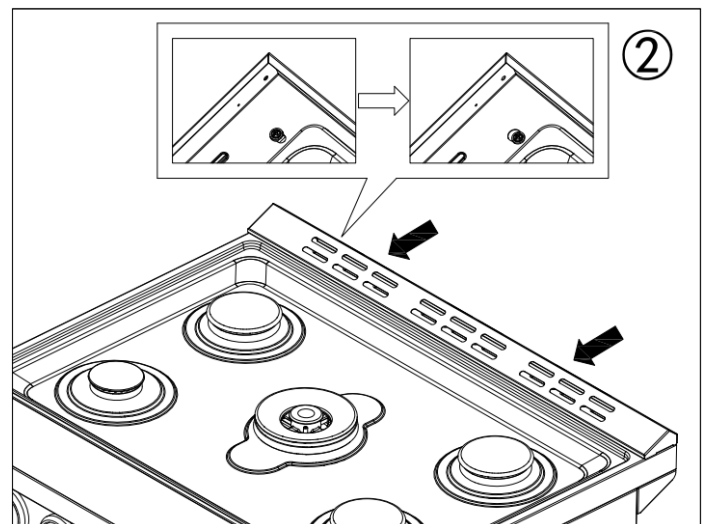
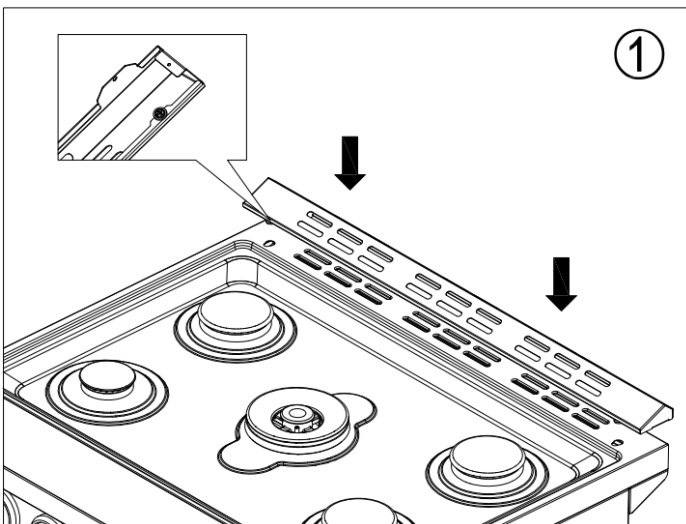

Step 1. Refer to the picture 1, align the two buttons that under the Backsplash with the holes that on the rear of the Cooktop panel surface.

Step 2. Refer to the picture 2, push the Backsplash to the front side, and let the buttons tighten with the holes.

Step 3. Refer to the picture 3, tighten 2 screws to fix the Backsplash.

Installation Instruction of Kickplate

Take out the kick panel from the parts box on the back. Follow the instructions below to install the kick panel.

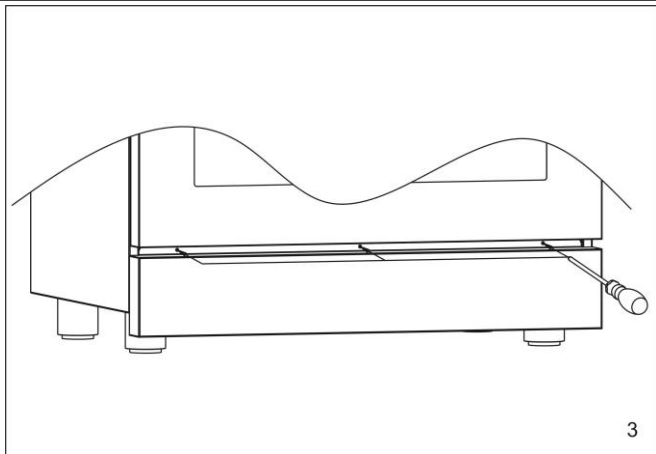
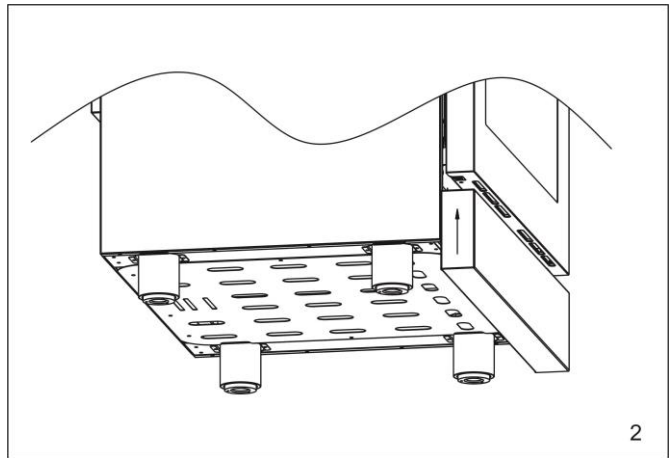
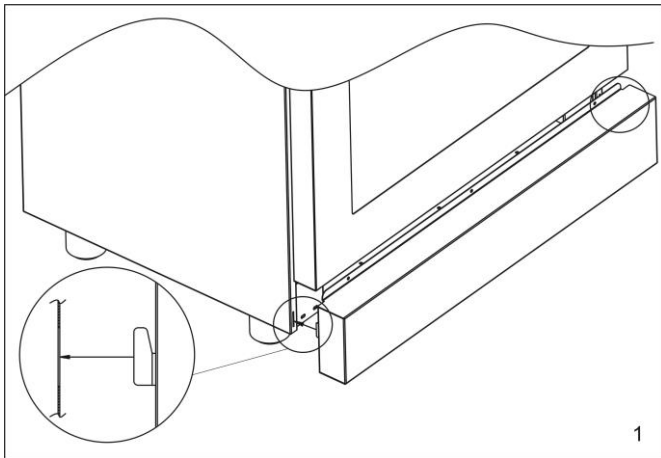

Step 1. Refer to the picture 1, insert the fixed hook to the slot position.

Step 2. Refer to the picture 2, push the kick panel up to fix the panel on the product.

Step 3. Refer to the picture 3, tighten 3 screws between the door and the kick panel as the picture to finish the installation.

Electrical

Your range must be electrically grounded in accordance with local codes or, in the absence of local codes, in accordance with the National Electrical Code (ANSI/NFPA 70, latest edition). In Canada, electrical grounding must be in accordance with the current CSA C22.1 Canadian Electrical Code Part 1 and/or local codes.

The power supply must be of the correct polarity. Reverse polarity will result in continuous sparking of the electrodes, even after flame ignition. If there is any doubt as to whether the power supply has the correct polarity or is properly grounded, have it checked by a qualified electrician.

ELECTRICAL REQUIREMENTS

Electrical Supply	Grounded, 110/120 VAC, 60 Hz
Service	15 amp or 20-amp dedicated circuit
Receptacle	3-prong grounding-type
Power Cord	5.5' (1.4 m)

Electrical grounding Instructions:

This range is equipped with a three-prong (grounding) plug for your protection against shock hazard and should be plugged directly into a properly grounded three-prong receptacle. **DO NOT** cut or remove the grounding pin from the plug.

⚠ WARNING

⚠ CAUTION

Label all wires prior to disconnection when servicing controls. Wiring errors can cause improper and dangerous operation. Verify proper operation after servicing

ELECTRICAL SHOCK HAZARD Disconnect electrical power at the circuit breaker box or fuse box before installing the appliance. Provide appropriate ground for the appliance. Use copper conductors only. Failure to follow these instructions could result in serious injury or death.

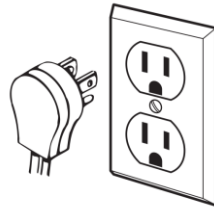

Grounding

The power cord is equipped with a three-prong(grounding) plug which mates with a standard three-prong grounding wall receptacle to minimize the possibility of electrical shock hazard from the range.

All cord connected appliances shall include instructions relative to location of the wall receptacle and a warning to the user to disconnect the electrical supply before serving the appliance.

Where a standard two-prong wall receptacle is encountered, it is the responsibility and obligation of the customer to have it replaced with a properly grounded three-prong wall receptacle. Do not cut or remove the grounding prong from the power cord.

Electric Power Supply Requirements

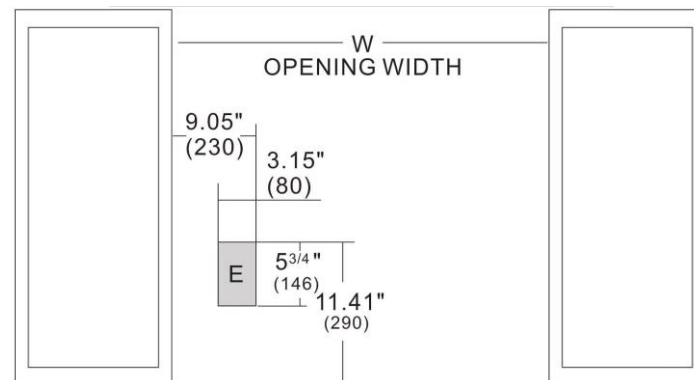

Gas Supply

Installation must comply with local codes or, in the absence of local codes, with the National Fuel Gas Code, ANSI Z223.1 / NFPA 54. In Canada, installation must conform to the current natural Gas Installation /code, CAN 1-1.1-M81 and with local codes where applicable.

This range has been design-certified Conforms to CSA/ANSI STD Z21.1-2018 Certified to CSA STD 1.1-2018 Household Cooking Gas Appliances

TYPE OF GAS:

NATURAL GAS	WC
Supply Pressure	5" (12.5 mb)
Minimum Supply Pressure	6"
Max Regulator Pressure	14" (34.9 mb), 0.5 psi (3.5 kPa)

LP GAS	WC
Supply Pressure	10" (25 mb)
Minimum Supply Pressure	11"
Max Regulator Pressure	14" (34.9 mb), 0.5 psi (3.5 kPa)

⚠️ WARNING

Do not obstruct the flow of combustion air into the range and ventilation air away from the range

Ventilation: it is recommended that the unit be operated with an oven head, vented exhaust hood of sufficient size and capacity.

Pressure regulator

Since service pressure may fluctuate with local demand, every gas cooking range must be equipped with a pressure regulator on the incoming service line for safe and efficient operation. The pressure regulator provided with the range has female threads 1/2" NPT for 30" range. The regulator is pre-installed on the gas range.

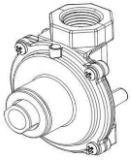

Pressure regulator can withstand a maximum input pressure of 0.5 psi (3.5 kPa) and is set at 5" WC outlet pressure when used on NATURAL GAS and 10" WC outlet pressure when used on LIQUID PROPANE.

Gas Shut-off Valve (not included)

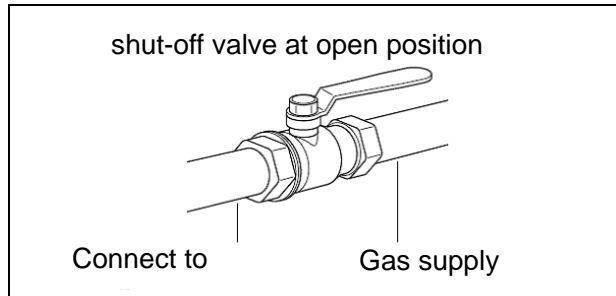

The supply line must be equipped with an approved external gas shut-off valve located near the range in an accessible location. Do not block access to the shut-off valve. Refer to the illustration above.

A 3/4" (19 mm) ID gas supply line must be provided to the range. If local codes permit, a certified, 3' (.9 m) long, 1/2" (13 mm) or 3/4" (19 mm) ID flexible metal appliance connector is recommended to connect the unit's 1/2" NPT or 3/4" NPT female inlet to the gas supply line. Pipe joint compounds suitable for use with natural or LP gas should be used.

The appliance and its shut-off valve must be disconnected from the gas supply piping system during any pressure testing of the system at test pressures more than 0.5 psi (3.5 kPa). The appliance must be isolated from the gas supply piping system by closing its individual manual shutoff valve during any pressure testing of the system at test pressures equal to or less than 0.5 psi (3.5 kPa).

Product Dimensions and Cabinets

Model#: FFSGS6211-30S, FFSGS6259-30S

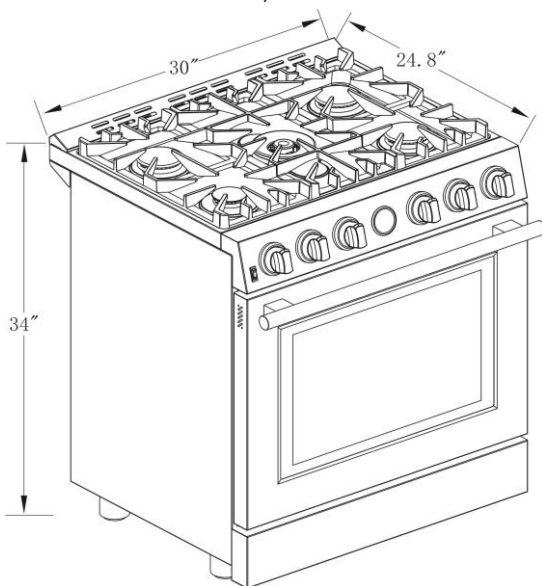

Model#: FFSGS6228-30S, FFSGS6242-30S

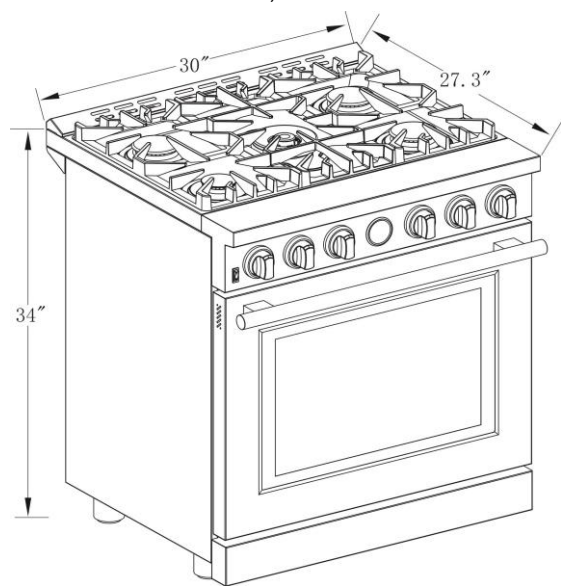

This range may be installed directly adjacent to existing countertop-height cabinets (34"-36" or 86-91 cm from the floor). To achieve the best look, the cooktop should be level with the cabinet countertop. This can be accomplished by raising the unit using the adjustment spindles on the legs.

Side Schematic

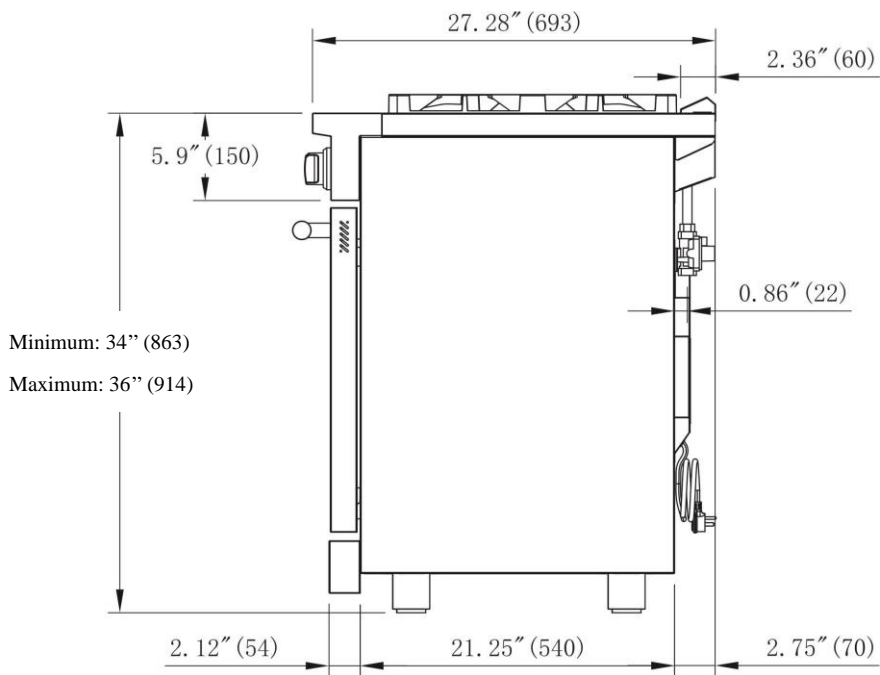
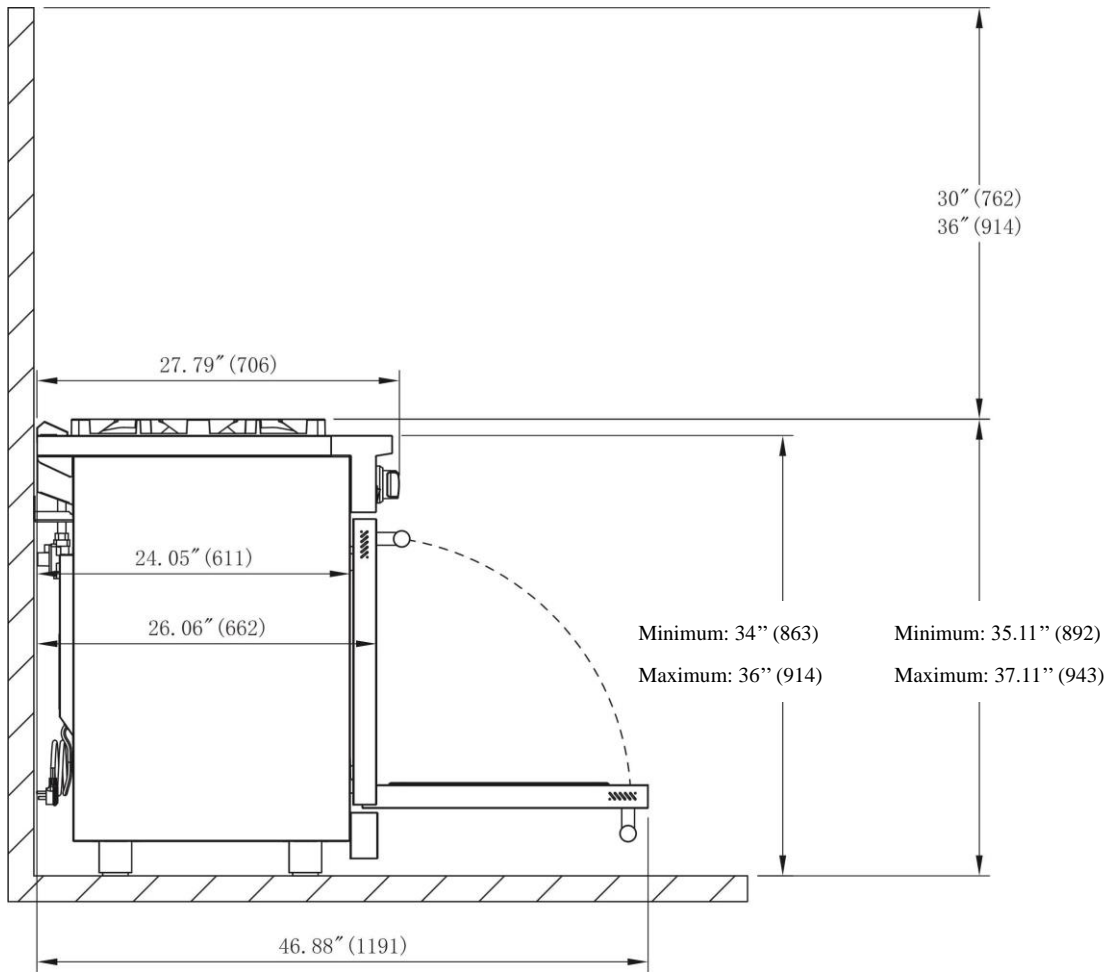

Back Schematic

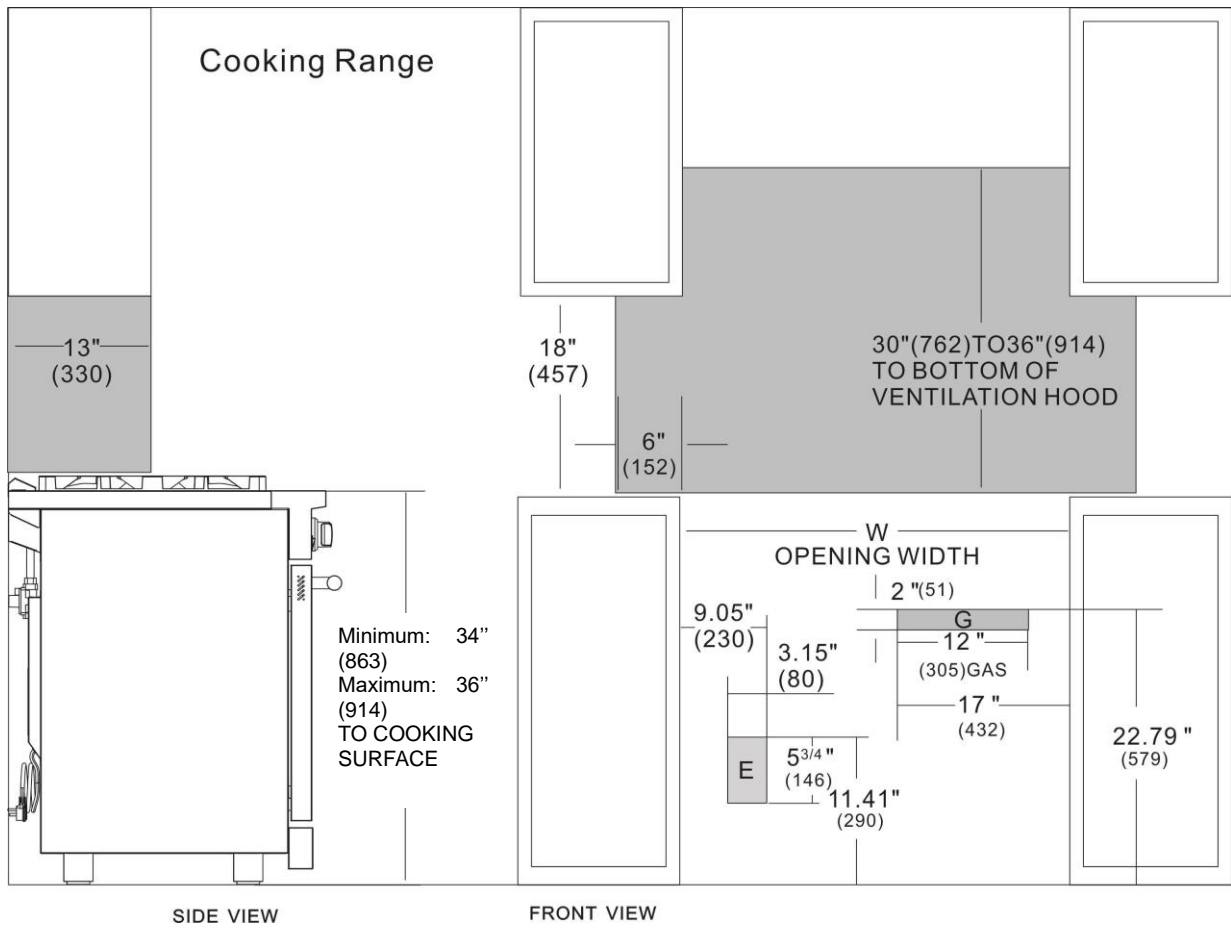
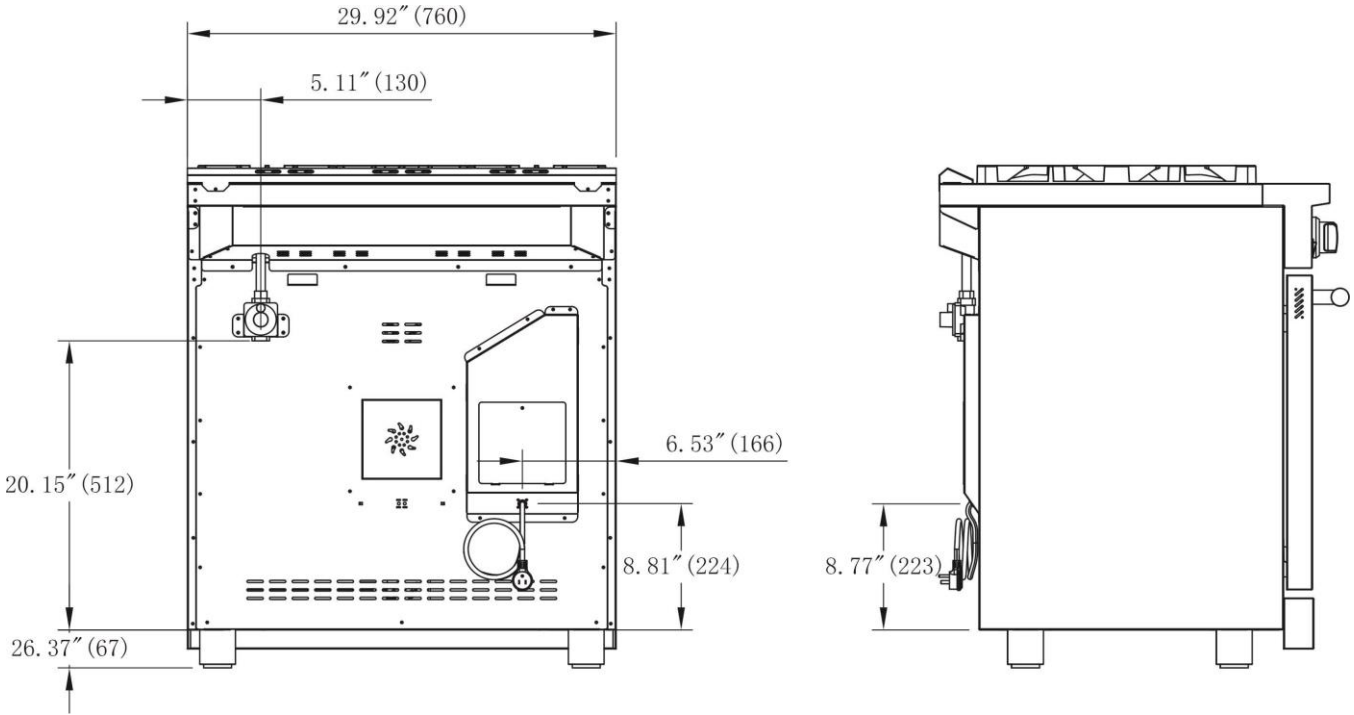

Opening width
30" Model

W
30" (762mm)

Exhaust Hood Installation

The bottom of the hood should be 30" min. to 36" above the countertop. This would typically result in the bottom of the hood being 64" to 72" above the floor. These dimensions provide safe and efficient operation of the hood.

After Installation:

1. Check ignition of surface burners.
2. Check the air shutter adjustment – sharp blue flame, with no yellow tipping or lifting flames.
3. Check ignition of oven burner.
4. Visually check tubular burner (oven burner) re-ignition to be sure both rows of burner ports are relighting each time.
5. Check for gas leaks at all gas connections (using a gas detector, never a flame).
6. Check oven bake, and convection bake function. (For some models have convection fan.)

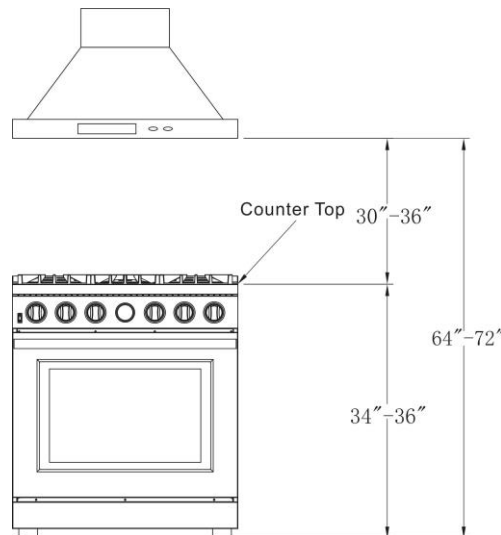

Gas Conversion Operation

This cooking range can be used with LP gas and NG gas. It is shipped from the factory adjusted for use with NG (Nature Gas). Injectors for LP gas are included. Follow the instructions shown below for gas conversion.

⚠️ WARNING

Gas conversion shall be conducted by a factory-trained professional. Call the customer service hotline to identify a factory-trained professional near your home.

⚠️ WARNING

Before carrying out this operation, disconnect the range from gas and electricity. Fail to do so, may result in fire, or electrical shock hazard can occur and result in injury or death. Do not remove regulator or allow it to turn during servicing.

The gas conversion procedure for this range includes 7 steps:

1. Pressure regulator
2. Surface burners
3. Oven burner
4. Broil burner
5. Range Top Gas Valve Adjustment
6. Gas valve (Oven)
7. Reconnect Gas and Electrical Supply
8. Installation of new rating label



The conversion is not completed if all 8 steps have not been concluded properly.

Before performing the gas conversion, locate the package containing the replacement injectors shipped with every range.

STEP 1: Pressure Regulator

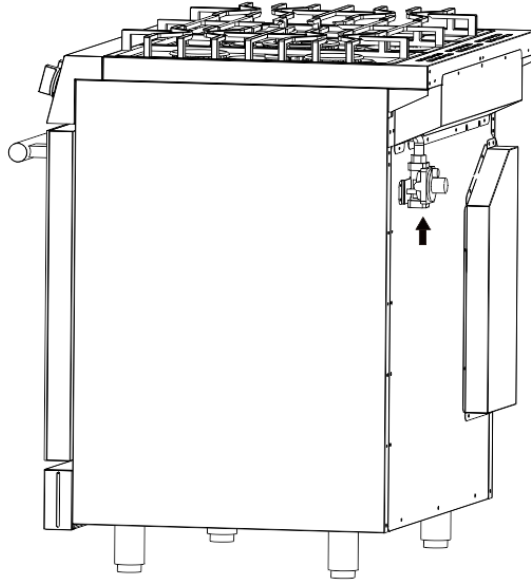
The regulator was pre-installed on the back side of the Gas Range.

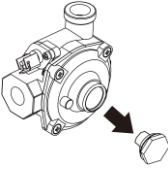

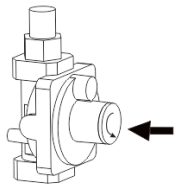
	 <p>Injector direction for NG Injector direction for LPG</p>	
<p>1.4) Unscrew the cap with injector from the regulator.</p>	<p>1.5) Unscrew the injector from the cap, the injector pre-installed for NG. Reverse the injector and screw it back to the cap can for LPG.</p>	<p>1.6) Screw the cap with injector back to the regulator.</p>

STEP 2: Surface Burners

- 2.1) Remove cooking grates and burner caps.
- 2.2) Lift off burner spreader.
- 2.3) Remove the factory installed natural gas injector from the nozzle holders by using a 7mm socket wrench.
- 2.4) Replace the LP injector in each nozzle holder. Tighten each injector properly. **Do not over tighten the injector.**
- 2.5) Place the burner spreader and caps back to correct position. Put back the cooking grates.

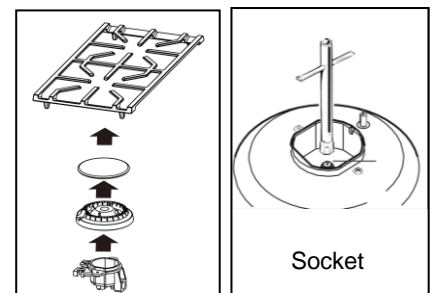

CAUTION

Handle carefully when removing and replacing gas components. Use proper support to prevent damage to components.

IMPORTANT: Each injector has a number indicating its flow diameter, the number is printed on the body. Consult the table below for matching nozzles with surface burners.

COOKTOP BURNERS			
ORIFICE FOR NATURAL GAS (NG) & LIQUID PROPANE (LP)	A. 5,000BTU	B. 9,000BTU	C. 18,000BTU
NG	1.04	1.36	1.82 (OUTER) 0.8 (CENTER)
LP	0.69	0.93	1.20 (OUTER) 0.48 (CENTER)

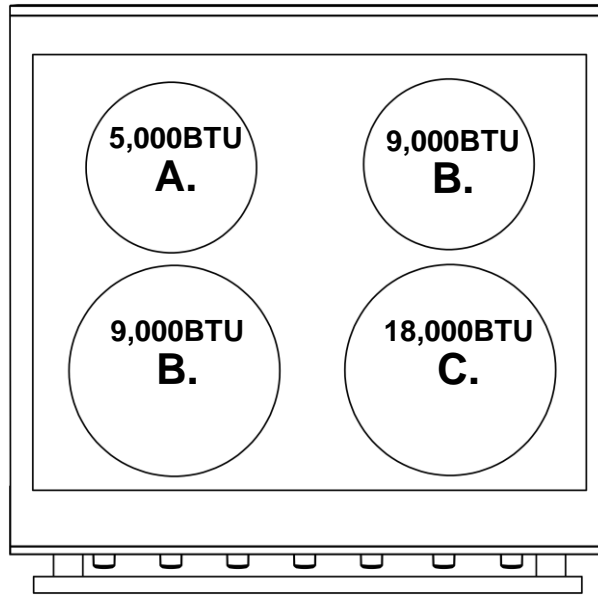

Model#: FFSGS6211-30S, FFSGS6228-30S

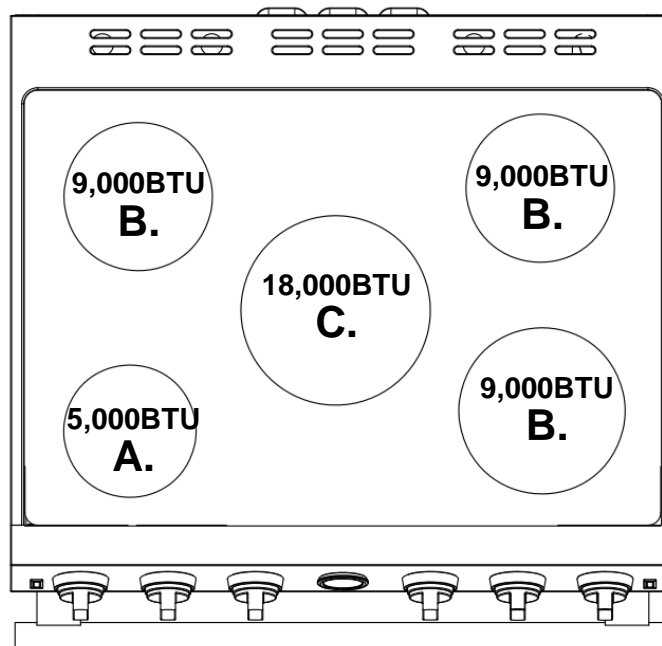

Model#: FFSGS6259-30S, FFSGS6242-30S

IMPORTANT: SAVE THE NOZZLES REMOVED FROM THE RANGE FOR FUTURE USE.

STEP 3: Oven Burner

The nozzle of the oven burner is located at the bottom rear of the cooking range.

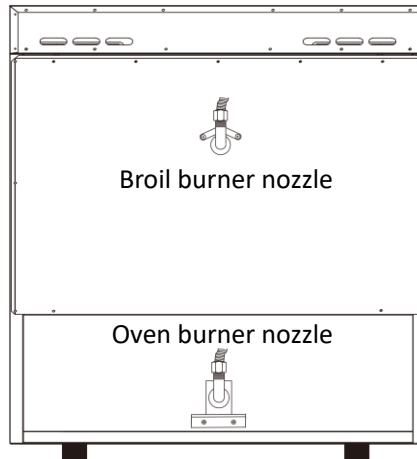

3.1) Pull the unit out of its place.

3.2) Open the oven door and take the oven bottom plate away, you can see the oven bottom burner.

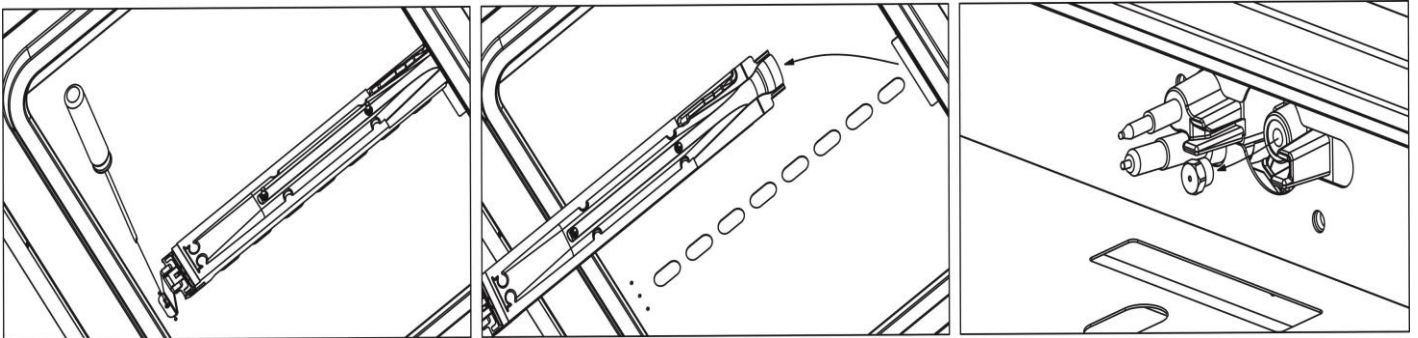

3.3) Remove 1 screw, take the bottom burner away. Replace the injector and tighten.

3.4) Assemble the oven bottom burner back to place.

Injector diameter for oven bottom burners:

Model#	FFSGS6211-30S	FFSGS6228-30S	FFSGS6259-30S	FFSGS6242-30S
NG	1.85	1.85	1.85	1.85
LPG	1.15	1.15	1.15	1.15

STEP 4: Broil Burner (oven top burner)

The broil burner nozzle is located at the middle top of cooking range back. Pull the unit out of its place.

Repeat the operation same as the **STEP 3** Oven burner to replace the broil burner nozzle.

Injector diameter for oven broil burners:

Model#	FFSGS6211-30S	FFSGS6228-30S	FFSGS6259-30S	FFSGS6242-30S
NG	1.50	1.50	1.50	1.50
LPG	0.97	0.97	0.97	0.97

IMPORTANT: Keep the injectors removed from the range for future use.

CAUTION! The following step outlines are intended to guide professional installers through the conversion process. It is crucial to note that these steps should not be attempted by individuals without proper certification or knowledge of gas appliances and installations. Only qualified professionals should undertake these procedures to ensure safety and compliance with relevant regulations.

STEP 5: Range Top Gas Valve Adjustment

After converting the gas range to propane, **it may be necessary to adjust the range top burners**. Typically, the surface burners do not require any adjustments. However, if you notice a flame that is either too large or abnormal, please follow the steps outlined below for proper adjustment.

5.1) Remove the cooktop burner knobs and knob rings from the control panel.

5.2) Insert a flat head screwdriver (2mm wide and 50mm long) to adjust the burner bypass screw; **Refer to picture 1 to adjust the 9000BTU burner or 5000BTU burner** and **refer to picture 2 to adjust the 18000BTU burner**.

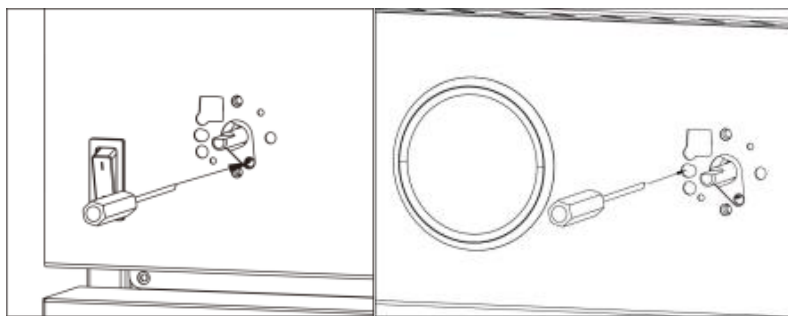

Picture 1.

Picture 2.

5.2.1) By turning the screwdriver clockwise the flame will decrease in size.

5.2.2) By turning the screwdriver counterclockwise the flame will increase in size.

5.3) Put back the knobs and knob base to the correct position.

WARNING! Exercise caution while adjusting the screw to avoid any issues. Over-tightening the screw will completely cut off the gas supply, while over-loosening it can result in excessive gas flow, potentially leading to gas leakage. Please ensure you make precise adjustments to maintain a safe and balanced gas flow.

STEP 6: Oven Gas Valve Adjustment

To ensure a successful and proper conversion to liquid propane, **it is essential to adjust the oven valve** following the instructions provided below. By carefully following these steps, you can complete the conversion process accurately and efficiently.

6.1) Remove the oven control knob and knob ring from the control panel.

6.1) Insert a flat head screwdriver (2mm wide and 50mm long) to adjust the burner bypass screw; **Refer to picture 3 & 4 to adjust the Oven Bake and Broil valve**.

6.2) To successfully complete the conversion of the oven, adjust the bypass screw of the oven valve by rotating it **270° clockwise**. This adjustment is a crucial step in the conversion process to ensure the proper functioning of the oven.

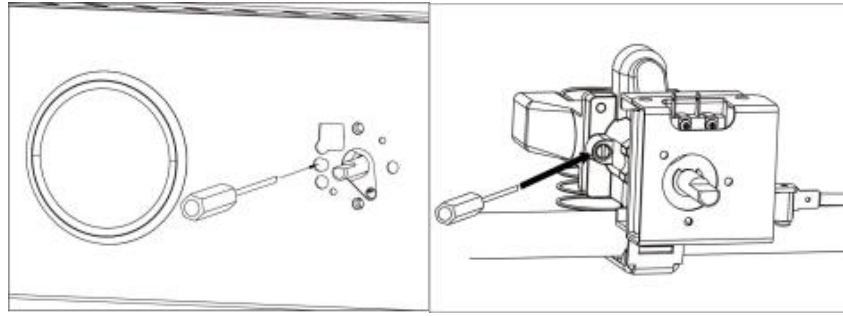

Picture 3.

Picture 4.

6.2.1) In rare instances where the flame appears too small, it may be necessary to adjust the bypass screw. To rectify this, carefully turn the bypass screw **270° counterclockwise** until the flame reaches a normal size. This adjustment should be undertaken sparingly and only if the flame is noticeably smaller than expected.

6.3) Put back the knob and knob ring to the correct position.

WARNING! Exercise caution while adjusting the screw to avoid any issues. Over-tightening the screw will completely cut off the gas supply, while over-loosening it can result in excessive gas flow, potentially leading to gas leakage. Please ensure you make precise adjustments to maintain a safe and balanced gas flow.

STEP 7: Reconnect Gas and Electrical Supply

Leakage testing of the range shall be conducted according to the installation instructions provided with the range. Before operating the range after the gas conversion, always check for leaks with a soapy water solution or other acceptable method at gas connections installed between the gas inlet pipe of the range, gas regulator, and the manual shut-off valve.

Use soapy solutions to check for leakage on all joints.

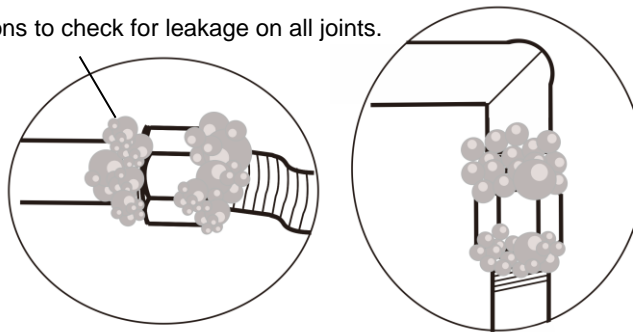

⚠️ WARNING DO NOT use a flame to check for gas leakage.

STEP 8: Installation of LPG Conversion Label

Record the model and serial number on the LP / Propane Conversion Label provided in this kit. The information can be obtained from the existing Rating / Serial label. Place the LPG conversion label as close as possible to the existing Rating / Serial label on the range.

Preparation

Before moving the range, protect any finished flooring and secure oven door(s) closed to prevent damage. The oven door(s) can be removed to lighten the load or to fit the unit through a doorway. Only remove if necessary. Do not remove the griddle or any other component. Door removal should only be done by a certified installer or service technician.

Placement

Do not lift or carry the oven door by the door handle. Use an appliance dolly to move the range near the opening. Remove and recycle packing materials. Do not discard the anti-tip bracket supplied with the range.

Leveling

Raise the range to the desired height by adjusting the legs. The legs can be adjusted by rotating clockwise to raise or counterclockwise to lower the range.

Anti-Tip Bracket

To prevent the range from tipping forward, the anti-tip bracket must be installed. Refer to the section of ANTI-TIP DEVICE.

Gas Supply Connection

All connections to the gas piping must be wrench-tightened. Do not over-tighten or allow pipes to turn when tightening.

When all connections have been made, check that all range controls are in the "OFF" position and turn on the main gas supply valve.

If a flexible metal connector is being used, verify it is not kinked, then attach the gas supply line to the regulator on the range. Open the valve and check for leakage by placing a liquid detergent solution onto all gas connections. Bubbles around connections indicate a gas leak. If a leakage is determined, close the shut-off valve, and fix the connections.

Leakage testing of the appliance shall be conducted according to the manufacturer's instructions. Use some soap water (50% water and 50% soap) or a leakage detector at all joints and connections to check for leaks in the system. Do not use a flame to check for gas leaks.

The appliance must be isolated from the building's gas supply piping system by closing its individual manual shut-off valve during any pressure testing of the gas supply piping system at test pressure equal to or less than 0.5 psi (3.5kPa).

Getting Started

Before you start cooking, please take the following steps.

- Remove all the exterior and interior packing.
- Remove the protective film on steel and aluminum parts.
- Clean the range thoroughly with hot water and a mild detergent. Rinse and dry with a soft cloth to remove any residual oil and grease left over from the manufacturing process.
- Check that surface burner components are assembled correctly.
- Furnish the interior of the oven by inserting the shelves and tray.

Surface Burner Operation

The burner assembly contains all accessories in one set. The burner cap must be seated on the burner horizontally. Refer to the illustration.

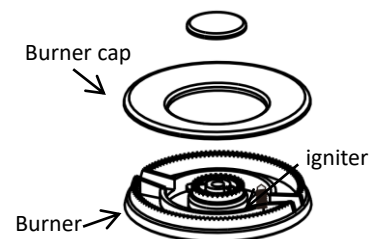

Ignition

To light up the cooktop burners, push and turn the appropriate control knob counterclockwise to "Max" position. You will hear a clicking noise – the sound of an ignition pin sparking.

Once burner ignition has been achieved, turn the burner control knob to adjust desired flame size. If the knob stays at "Max", it will continue clicking.

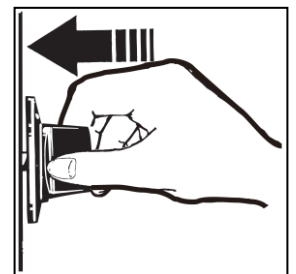

Heat Settings:

Max	Ignite the burners.
Simmer	Melting small quantities, steaming rice, warming food, melting chocolate or butter.
Min	Melting large quantities.
Min-Medium	Low-temperature frying, simmering large quantities, heating milk, cream sauces, gravies.
Medium	Sauteing and browning, braising, pan-frying, maintaining slow boil on large quantities.
Medium-Max	High-temperature frying, pan boiling, maintaining slow boil on large quantities.
Max	Boil liquid quickly, deep frying.

⚠ CAUTION

Never leave pans on a high setting unattended. Be careful when cooking food in fat or grease; it can become hot enough to ignite. Burner flames not covered by cookware present a risk of fire or clothing ignition. Never let flames extend beyond the sides of the cookware. Failure to comply may result in serious injury.

Simmer and Boil

A smaller flame will give the best results when simmering. Small flames offer precise cooking performance for delicate foods, keeping food warm, melting chocolate or butter, and for cooking over low heat for long period of time.

The highest (larger) flame settings provide the maximum heat that is available on your range. This setting should be used for heavy cooking jobs such as boiling water and cooking pastas.

Flame Size

- When you adjust the flame size, watch the flame when you turn the knob.
- Any flame exceeding the bottom of the cookware will not heat faster and may be hazardous.
- The flame should be steady and blue in color. Impurity in the gas supply may cause an orange flame during initial operation.



Power Failure

- If the gas does not ignite within 4 seconds, turn off the valve and allow at least five minutes for any gas to dissipate. Repeat the lighting procedure.
- In the event of a power failure, the surface burners can be lighted manually. Hold a lighted match near a burner and turn the knob counterclockwise to "HI". After burner lights, turn knob to the desired setting.

Burner Grills

1. The grills must be properly positioned before cooking. Improper installation of the grills may result in scratching of the cooktop and / or poor combustion.
2. Do not operate the burners without a pan or utensil on the grills.

Instruction of choosing the diameter of pot according to the burner power

1. Please use a pot with a minimum diameter of 12" on the burner with 18000BTU (Left front burner of Model# FFSGS6211-30S, FFSGS6228-30S & Middle burner of Model# FFSGS6259-30S, FFSGS6242-30S).
2. Please use a pot with a minimum diameter of 10" on the burner with 15000BTU (Right front burner of Model# FFSGS6211-30S, FFSGS6228-30S, FFSGS6259-30S, FFSGS6242-30S).
3. Please use a pot with a minimum diameter of 9" on another burner.

⚠ CAUTION

The surface of the grill is hot after use. Please allow sufficient time for the grill to cool before cleaning.

Cooktop cleaning tips

- To prevent the cooktop from discoloring or staining, clean cooktop after each use, and wipe up acidic or sugary spills as soon as the cooktop is cooled.
- The sealed burners of your range are not secured to the cooktop and are designed to be removed easily. Boiling overs or spills will not seep underneath the cooktop. The burners should be cleaned after each use.

Oven Light

The oven light is controlled by a push switch on the control panel.
The light can be used while cooking or cleaning the oven.

⚠️WARNING

Before replacing the oven light, make sure power is disconnected from the electrical box and the oven is cooled completely. Disassemble the light cover and replace the light bulb with a 25-watt halogen bulb. Install the light cover properly.

Oven Operation

Temperature gauge

1. The gauge shows the oven temperature in both CELSIUS degree and FAHRENHEIT degree.
2. Correct reading can be obtained when the temperature inside the oven is steady.
3. The mechanical thermometer is sleeplessly adjustable, and the temperature setting operation may not accurately correspond to the dial. For the temperature, please refer to the temperature indicated on the knob.



Oven Ignition

The oven is equipped with an ignition system which contains pilot flame function and safety device. To light up the oven burner, push and turn the oven control knob anti-clockwise to reach IGNITE position and hold it. You will hear a clicking noise - the sound of an ignition pin sparking. Hold the knob until you can see the pilot flame on.

To light up the broil burner, push and turn the oven control knob clockwise to "Broil" position and hold it. You will hear a clicking noise - the sound of an ignition pin sparking. Hold the knob until you can see the burner is lit up.

DO NOT RELEASE the knob before you can see the flame comes up. If fail to light up the oven burner within 10 seconds, reset the oven control knob to the "OFF" position, repeat above operations until the oven burner is properly ignited.

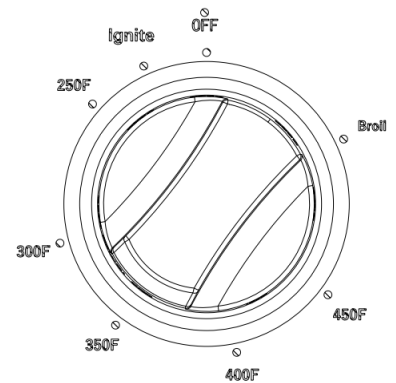

IMPORTANT

The safety device is equipped with the oven burner. When the flame goes out by accident, the gas supply will be shut off automatically. You need to turn the control knob back to the "OFF" position and ignite again.

⚠️WARNING

If fail to light up the oven burner 3 times continuously, the oven might be full of the gas, then open the oven door to allow gas dissipating before operating ignition again. Otherwise, the oven may explode, and the user will get hurt.

Oven Baking Tips

For fast exhausting the smell of "burning" or "oily" odor emitting from a new oven, turn the oven knob to "Broil" and run for 30 minutes before initial use.

1. **Never cover any slots, holes or passages in the oven bottom or cover an entire rack with materials such as aluminum foil. Doing so blocks air flow through the oven and may cause carbon monoxide poisoning. The aluminum foil lining may also trap heat, causing a fire hazard. Do not use aluminum foil on any porcelain surface. Doing so will damage the porcelain and affect its durability.**
2. Position the racks before preheating the oven.

Preheating

Allow the oven to preheat before placing food in the oven. Preheating is necessary for good results when baking cakes, cookies, pastries, and bread.

Remove the broiler pan before preheating with the infrared broiler. Foods will stick on hot metal.

To preheat, turn the "Oven" control knob to the "Broil" position. Wait for the burner to become hot, approximately in 2 minutes.

Note: Condensation or fogging on the inside of the oven door glass is normal while preheating and it will usually evaporate by the end of the preheating cycle

Oven Function

Natural Airflow Bake occurs when heat is transferred into the oven from the bake burners in the bottom of the oven cavity. Heat is then circulated by natural airflow. This is a traditional bake setting.

Convection Bake (For some models have convection fan.)

Heat is transferred from the bake burners in the bottom of the oven cavity to the oven cavity itself.

The convection fan at the rear of the oven then circulates it. This convection process provides a more even heat distribution throughout the oven cavity.

Using multiple racks is possible for large-batch baking. Convection cooking is faster, can be done at lower temperatures and provides more even temperatures than regular cooking.

Please note: This unit was designed to turn ON the Convection fan automatically when setting the temperature of the oven. The fan will stop automatically only when setting the broil function or when the temperature is lower than 250°F.

Convection Roast (For some models have convection fan.)

The convection fan circulates the heated air evenly over and around the food. Using the cover and broiler pan (not provided), heated air will be circulated over the around the food being roasted. The heated air seals in juices quickly for a moist and tender product, while at the same time creating a rich golden-brown exterior. When convection roasting, it is important that you use the broiler pan for the best convection roasting results. The pan is used to catch grease spills and has a cover to prevent grease splatters.

Broiler Operation

Note: Door must be closed during broiling operation.

The broil burner is located at the top of the oven. This burner heats the metal screen until it glows. The glowing screen produces heat, searing the outside of broiled foods and sealing in juices. Broiling is a method of cooking tender cuts of meat directly under the broiler in the oven.

Oven broiling is done with the oven door closed. It is normal and even necessary to have some smoke to give the food a broiled flavor.

Setting Broil

Turn the oven control knob clockwise to select the Broil function. When broiling, heat radiates downward from the oven broiler. The temperature of Broil feature is 500°F (260°C).

Used together, the broiler pan and insert (**not included**) allow dripping grease to drain and be kept away from the high heat of the oven broiler. **DO NOT** use the broil pan without the insert. **DO NOT** cover the broil pan insert with foil. The exposed grease could catch fire. To set the oven to Broil:

1. Place the insert on the broiler pan. Then place the food on the pan insert.
2. Adjust the interior oven rack to the desired position and place the broiler pan on the rack. Be sure to center the pan and position it directly under the broil burner. (If preheating is needed, put in the pan after the broil burner reaches the temperature.)
3. Turn the control knob to Broil setting position.

The oven indicator will remain on until the control knob is turned to the OFF position, or the temperature control cycles off.

Position the rack at the correct level. The farther away the food is from the broiler, the more well done it will be inside. Preheating the oven is not necessary. Push in and turn the knob to BROIL. Turn the food over at the halfway point. Always pull the rack out to the “stop” position before turning or removing food.

Oven Cleaning Tips

1. After each use, and once the oven is cooled, clean splatters and spills immediately.
2. Do not allow foods with a high sugar or acid content to remain on the oven cavity surface.
3. Use an oven cleaner to clean the oven cavity.

Oven Steam Clean Function:

1. Remove all racks and oven accessories.
2. Scrape or wipe loose debris and grease from the oven bottom.
3. Pour 1 cup of tap water onto the oven bottom. Close oven door.
4. Use the oven bake function, turn the knob to the temperature 300°F.
5. Wait about 5 minutes, then turn off the oven burner and let the steam fill the oven to help to clean the cavity.



Oven Thermostat & Cooking time

The numbers printed on the control panel indicate the oven temperature setting value (°F). To set the temperature, adjust the control knob indicator to line up with the desired number on the control panel.

Note: The BROIL function is only for turning on the broil burner.

Cooking times can vary according to the type of food, its density, and its size. It is advisable to watch when cooking for the first time and to check results since similar results are obtained when preparing the same dishes under the same conditions.

Use the thermostat to control the temperatures and control the time according to the cooking guides.

Thermostat is equipped in the oven, when the oven temperature reaches the setting, the oven temperature will stay relatively stable. The actual oven temperature can be read from the gauge on the control panel.

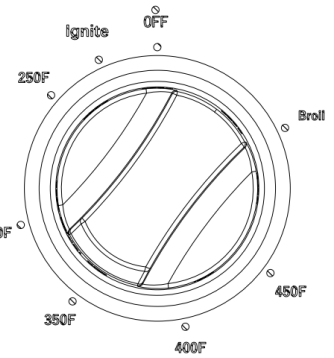

Care and Maintenance Recommendations

Stainless steel	Use non-abrasive stainless-steel cleaner, apply small amount to a soft cloth, slightly wipe the stainless-steel surface, then towel dry. When wiping on the stainless-steel surface, always follow the grain of the metal.
Burner grills Oven rack guides	Clean with hot water and mild detergent or mixture of baking soda and water. Do not immerse in water. Towel dry.
Burner pan	Remove surface debris before cleaning to help speed up the process and decrease the chance of scratching the surface during cleaning. Using mild abrasive cleaners or spray degreasers, clean and rinse the surface and dry immediately. To clean hard water stains, use white vinegar and water. Rinse and dry immediately.
Cooktop burners	After cooling down, use mild detergent or spray degreaser to clean. Rinse with water and towel dry.
Control knobs	Using a damp cloth, wipe with a mild detergent or spray degreaser; rinse and dry. Do not place in dishwasher.
Oven interior	Use mild abrasive cleaners, spray degreasers. Use a razor blade to gently remove baked on foods from oven cavity and window. For stubborn stains, spray with a mild abrasive cleaner or spray degreaser. Clean the entire oven cavity with soap and water.
Broiler pan	To clean the upper rack, use mild detergent and a scouring pad. Rinse and dry. To clean the bottom pan, discard grease and wash with hot water and mild detergent. Rinse and dry.

Troubleshooting Tips

Before you call for service

Range does not operate	Check that the power is on. Check that electrical power to range and home circuit breaker is on.
Burners Do Not Light or Spark Randomly	Electrical plug is not connected properly with a live power outlet. Gas supply not turned on. Burner parts not replaced correctly. Holes in the simmer rings or slits in the burner rings are clogged. Clogged nozzles, or wet burners or electrodes. A fuse in your home may be blown or circuit breaker tripped.
Burners Have Yellow Or Yellow-Tipped Flames	Burner parts not replaced correctly. A. Yellow flames: Call for service. B. Yellow tips on outer cones: Normal for propane (LP) gas. C. Soft blue flames: Normal for natural gas. If burner flames look like (A), call for service. Normal burner flames should look like (B) or (C), depending on the type of gas.  (A), (B), (C)
Burner Flames Very Large Or Yellow	The range may be connected to the wrong fuel type. Contact the person who installed your range or made the conversion.

Burner Flames Contain Orange Flickers	Airborne dust; cool-mist humidifier; debris on or inside burner.
Oven Lights Do Not Work	The light bulb is defective. Replace the bulb.
Oven Racks Are Hard to Slide	Do not use a cooking spray or other lubricant sprays to make it smooth. Refer to oven racks cleaning in the Care and Maintenance section.
Food Does Not Bake or Roast Properly	The oven controls are improperly set. See the Baking or Roasting section. Oven not preheated for enough time. Incorrect cookware or cookware of improper size being used. Racks in the wrong position. See the Baking or Roasting section. Use a foil tent to slow down browning during roasting.
Food Does Not Broil Properly	This model is designed for closed door broiling only. Always broil with the door closed. The oven controls are not set at BROIL. See the Broiling section. Improper rack position. Cookware is not suited for broiling. Aluminum foil used on the broiling pan and rack has not been fitted properly and slit as recommended.
Steam From the Vent	When using the convection mode, it is normal to see steam coming out of the oven vent. As the number of racks or amount of food being cooked increases, the amount of visible steam will increase.
Burning Or Oily Odor Emitting from The Vent	This is normal in a new oven and will disappear in some time.
Strong Odor	This is temporary. An odor caused by the insulation around the inside of the oven is normal for the first few times the oven is used.
Condensation Or Fogging on The Glass of inside of Oven Door.	Condensation or fogging on the glass of inside of oven door is normal during the preheating of the oven and will evaporate usually by the end of the preheating cycle.
Cracking Or Popping Sound During Cleaning	This is normal. This is the sound of the metal heating and cooling during both the cooking and cleaning functions.
Excessive Smoking Occurs During Cleaning	The oven is heavily soiled. Turn the oven control knob to OFF. Open the windows to exhaust. Wait until the oven is completely cooled. Wipe up excess soil and do the cleaning again.

WIRE DIAGRAM

FFSGS6228-30S,FFSGS6211-30S

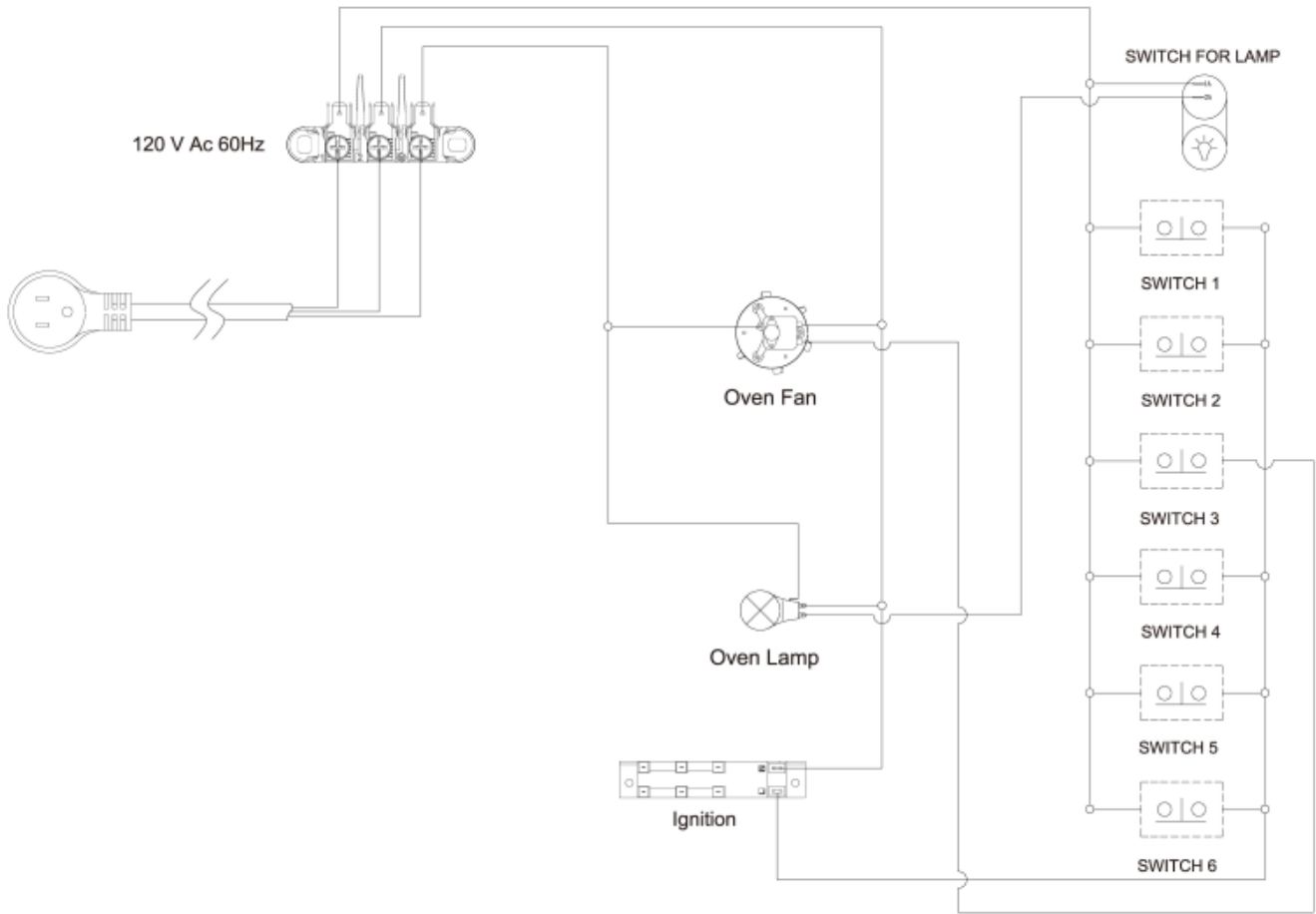

Caution: Label all wires prior to disconnection when servicing controls. Wiring errors can cause improper and dangerous operation. Verify proper operation after servicing.

FFSGS6242-30SF,FSGS6259-30S

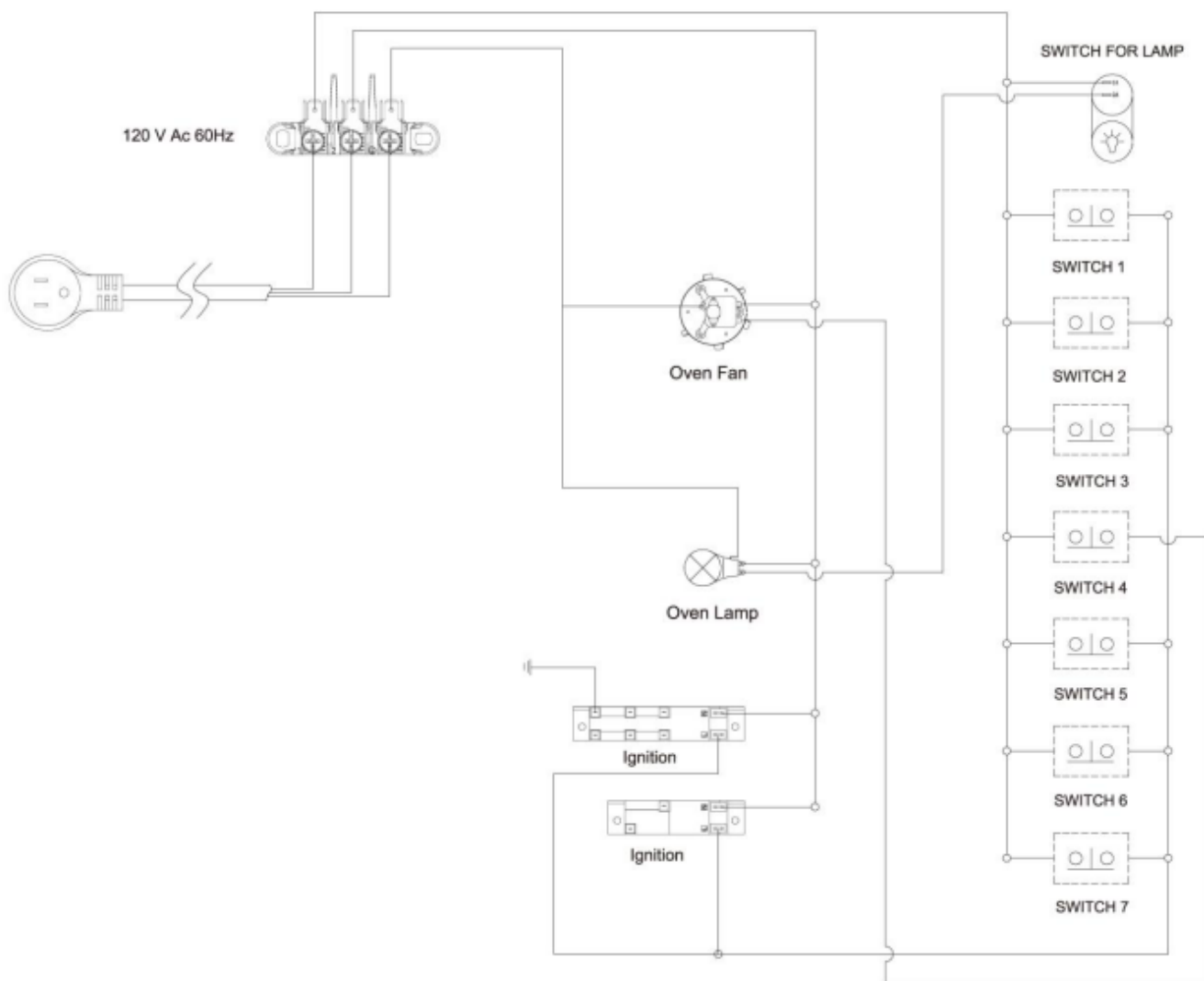

Caution: Label all wires prior to disconnection when servicing controls. Wiring errors can cause improper and dangerous operation. Verify proper operation after servicing.