

SWISHER

**Owners
Manual**

**MODEL NO.
11730**



IMPORTANT
Read and follow all
Safety Precautions
and Instructions
before operating this
equipment.

REV 08-086

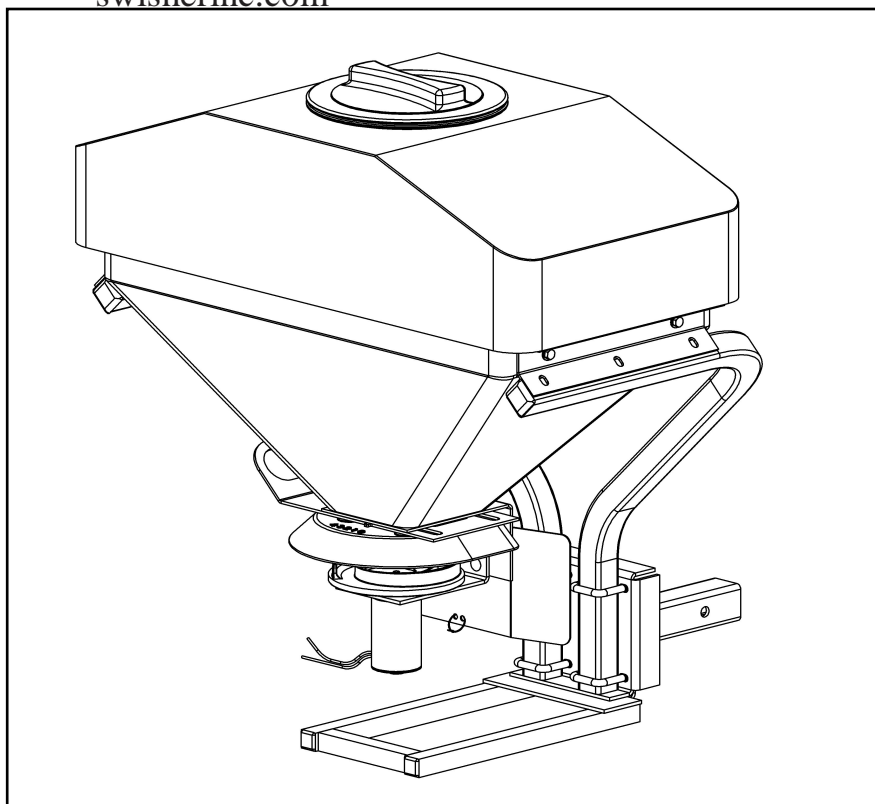

TRUCK SPREADER

**Assembly
Replacement Parts**

SWISHER

1602 CORPORATE DRIVE, WARRENSBURG, MISSOURI 64093
PHONE 660-747-8183 FAX 660-747-8650

Manufacturing quality lawn care equipment since 1945

Made In The

USA

LIMITED WARRANTY

The manufacturer's warranty to the original consumer purchaser is: This product is free from defects in materials and workmanship for a period of one (1) year from the date of purchase by the original consumer purchaser. We will repair or replace, at our discretion, parts found to be defective due to materials or workmanship. This warranty is subject to the following limitations and exclusions:

- 1) Commercial Use This product is not intended for commercial use and carries no commercial warranty.
- 2) Limitation This warranty applies only to products which have been properly assembled, adjusted, and operated in accordance with the instructions contained within this manual. This warranty does not apply to any product of Swisher that has been subject to alteration, misuse, abuse, improper assembly or installation, shipping damage, or to normal wear of product.
- 3) Exclusions Excluded from this warranty are normal wear, normal adjustments, and normal maintenance.

In the event you have a claim under this warranty, you must return the product to an authorized service dealer. All transportation charges, damage, or loss incurred during transportation of parts submitted for replacement or repair under this warranty shall be borne by the purchaser. Should you have any questions concerning this warranty, please contact us toll-free at 1-800-222-8183. The model number, serial number, date of purchase, and the name of the authorized Swisher dealer from whom you purchased the product will be needed before any warranty claim can be processed.

THIS WARRANTY DOES NOT APPLY TO ANY INCIDENTAL OR CONSEQUENTIAL DAMAGES AND ANY IMPLIED WARRANTIES ARE LIMITED TO THE SAME TIME PERIODS STATED HEREIN FOR ALL EXPRESSED WARRANTIES. Some states do not allow the limitation of consequential damages or limitations on how long an implied warranty may last, so the above limitations or exclusions may not apply to you. This warranty gives you specific legal rights and you may have other rights, which vary from state-to-state. This is a limited warranty as defined by the Magnuson-Moss Act of 1975.

Item #	Part #	Description
1	10113	Deflector - Spreader
2	NB505	Bolt - 5/16-18 X 1 1/2 HCC GR5 ZY
3	NB556	Washer - USS Flat, 5/16 ZY
4	NB579	Washer - Fender, 5/16 X 1 1/4 OD ZY
5	7825Z	Bushing - Lift Bar
6	10051	Spring - Gate, 12V ATV Spreader
7	NB555	Washer - USS Flat, 1/2 ZY
8	10112TK	Gate - Hopper
9	10111TK	Bracket - Motor Support, Upper
10	NB181	Nut - Nyloc 5/16-18 ZY
18	10192	Washer - Nylon Retainer 5/16"
20	10975	Tank - Truck Spreader

Step 1:

Assemble the components as shown. Use the Nylon Retainer Washer (18) to hold the parts together.

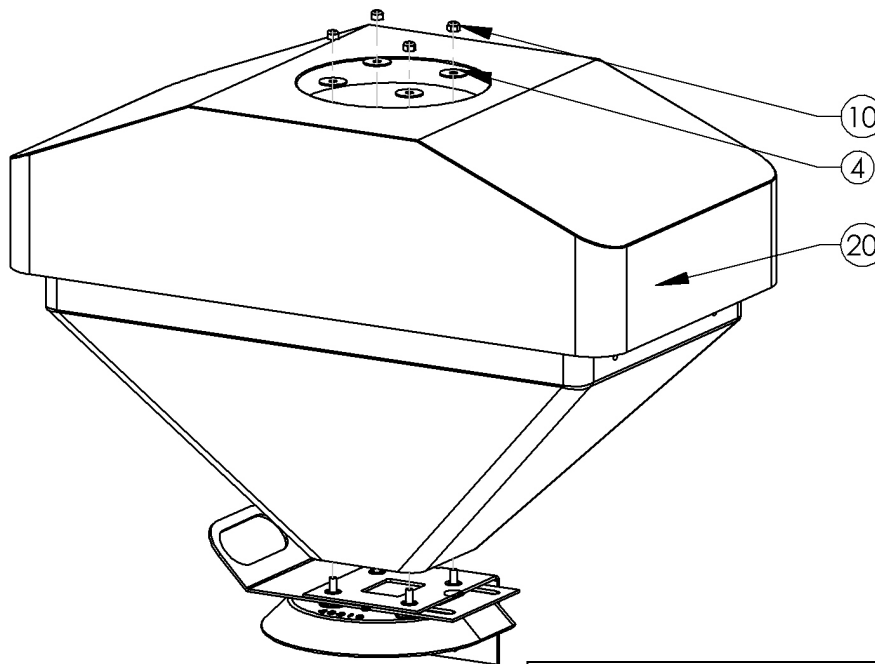
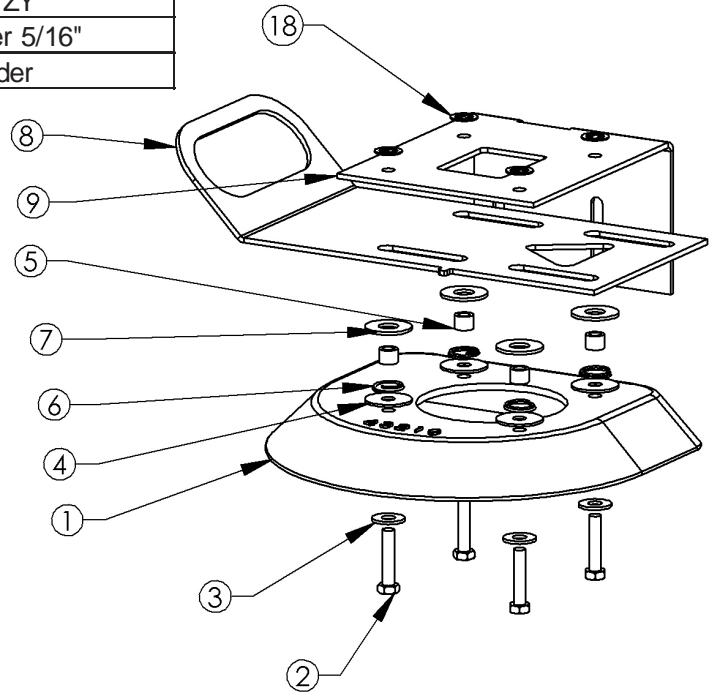

Step 2:

Attach the assembly made in Step 1 to the tank (20) by sliding the bolts (2) up through the tank and placing a fender washer (4) over each bolt. Thread a nut (10) over each bolt and tighten securely.

NOTE: To change the amount of material being spread, adjust the hopper gate by pulling on the handle until the desired flow is attained. A scale of one to four has been provided with one being the least amount, and four being the most. Zero will seal the material from being distributed.

Item #	Part #	Description
9	10111TK	Bracket - Motor Support, Upper
11	10114TK	Bracket - Motor Support, Lower
12	10197	Bolt - Carriage 5/16-18 X 1 GR5
13	10117TK	Shield - Spreader
14	3844	Knob - T, 5/16-18
15	15118	Motor - Spreader 12 VDC CW 2.5"
16	10118	Spinner - Distributor, Spreader

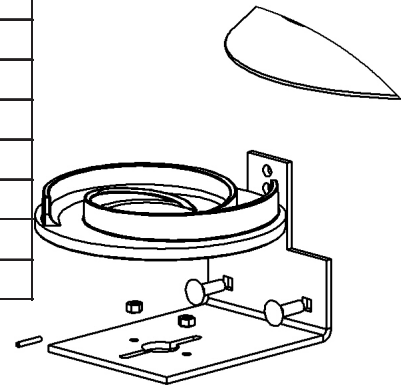

Step 3:

Remove the nuts and snap ring from the motor and place the Lower Motor Support Bracket (11) over the Motor (15). Thread the nuts onto the motor studs and tighten. Slide the Spinner/Distributor (16) over the motor shaft and replace roll pin.

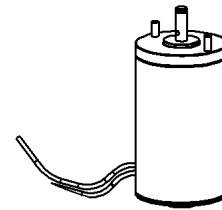

DETAIL B
SCALE 1 : 5

Step 4:

Insert the 5/16" Carriage Bolts (12) into the Lower Motor Bracket (11), through the Upper Motor Bracket (9), and through the Spreader Shield (13). Place the T-Knobs (14) on the bolts (12) and tighten. (The guide of the Lower Bracket will slide up through the slot in the Upper Bracket).

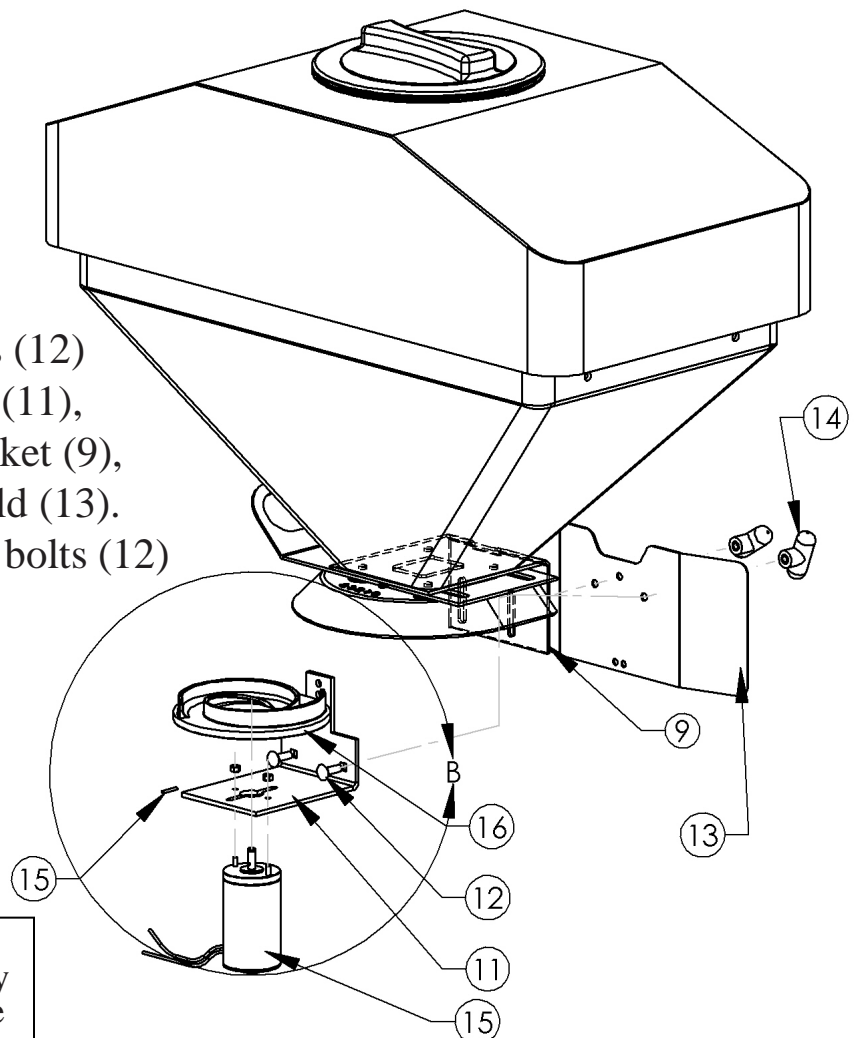

NOTE: To change the radius of material being spread, simply loosen the T-Knobs and slide the mechanism up (smaller radii) or down (larger radii).

Item #	Part #	Description
3	NB556	Washer - USS Flat, 5/16 ZY
10	NB181	Nut - Nyloc 5/16-18 ZY
21	10976TK	Support - Weldment, LH; Truck Spreader
22	10979TK	Support - Weldment RH; Truck Spreader
24	NB501	Bolt - 5/16-18 X 1 HCC GR5 ZY
25	NB579	Washer - Fender, 5/16 X 1 1/4 OD ZY GR2

Step 5:

Attach the Support Tube Weldments (21 & 22) to the tank by inserting the bolts (24) through the Washers (25) and the Weldments (21 & 22), and into the holes on the side of the tank as shown. Place a washer (3) over each bolt (24) on the inside of the tank and thread the nuts (10) onto the bolts (24) and tighten securely.

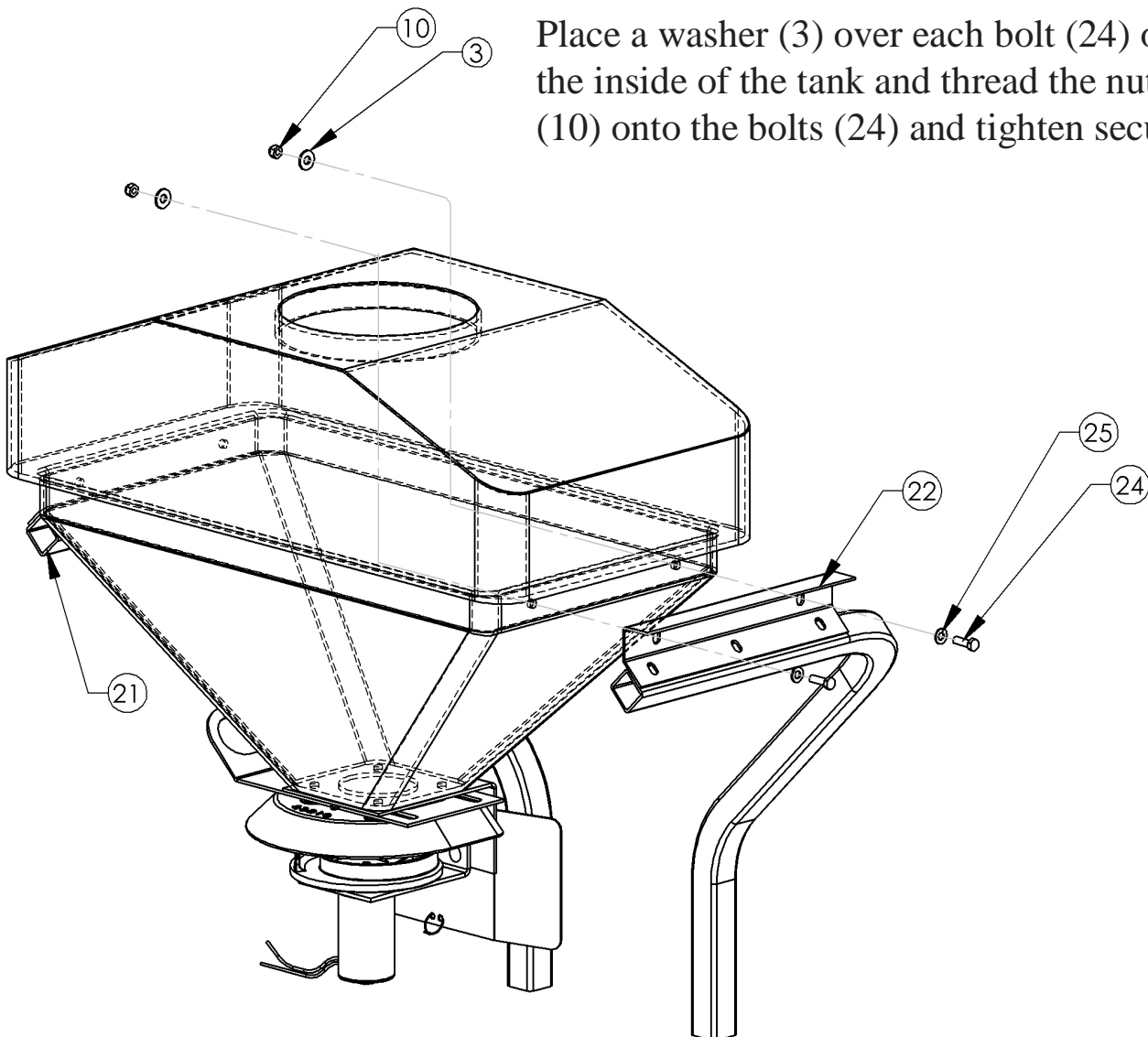

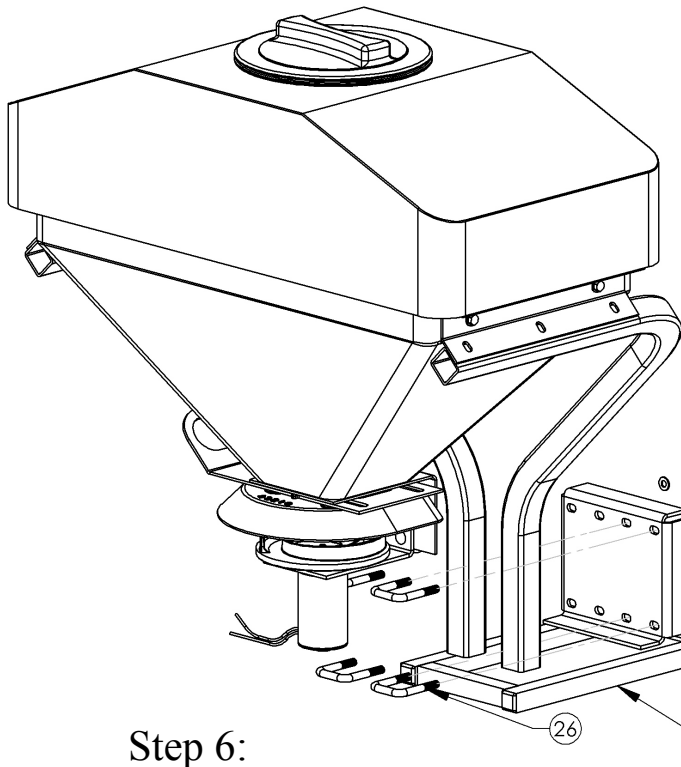

Item #	Part #	Description
10	NB182	Nut - Nyloc 3/8-16 ZY
23	10981TK	Mount - Weldment; Truck Spreader
25	NB272	Washer, 3/8
26	9855	Bolt - U, Sq 3/8-16 x 1 5/8" x 2 1/2"
27	11728TK	Support - Weldment; Truck Spreader
	10176	Lid - Tank
	10531	Adapter - Kit, 12 Volt

Step 6:

Attach the Mounting Weldment (23) to the Spreader Assembly by putting the U-Bolts (26) over the Mounting Tubes (21 & 22) and into the holes on the Mounting Weldment (23). Mount the Support Weldment (27) onto the rear of the Mount Weldment (23) and place the Washers (25) onto the Bolts (26) as shown and thread the Nuts (10) in place. Making sure that the support tubes are resting on the lip provided, tighten the nuts, securing the Mounting Weldment (23) and Support Weldment (27) to the Spreader Assembly.

Power Hook-Up:

After assembling the Spreader, you must hook up the 12 Volt Spreader Motor. To do this you must first route the wires coming out of the male end of the 12 Volt Power Source through your Truck, and back to the rear of your truck. (be sure to allow enough wire to be able to plug and unplug the power source from the receiver located on your truck). Next, tie the wires from the motor through the holes located on the bottom of the Spreader Shield using the nylon tie supplied. Connect these wires to the ones coming from the 12 Volt Power Supply.*

To operate, simply plug in the 12 Volt Power Supply, and begin using your Swisher Spreader.

*Note: When hooking up the electrical, test the rotation of the motor shaft. Looking down on the motor shaft, the shaft should rotate clockwise. If the direction is counter clockwise, switch the wires coming out of the motor that plug into the 12 volt power source.

MATERIAL SPREADING CHART

(Calibrated at 4 MPH Ground Speed)

PRODUCT	Setting #1	Setting #2	Setting #3	Setting #4	SPREAD WIDTH
Fertilizer	41 lbs/Acre @ 4 mph	169 lbs/Acre @ 4 mph	NA	NA	12 ft
	20 lbs/Acre @ 8 mph	84 lbs/Acre @ 8 mph	NA	NA	
Rock Salt	NA	NA	226 lbs/Acre @4 mph	352 lbs/Acre @4 mph	12ft
	NA	NA	113 lbs/Acre @8 mph	176 lbs/Acre @ 8 mph	
Dry Sand	151 lbs/Acre @4 mph	536 lbs/Acre @4 mph	NA	NA	9ft
	75 lbs/Acre @8 mph	268 lbs/Acre @8 mph	NA	NA	
Barley	NA	56 LBS/Acre @4 mph	170 lbs/Acre @4 mph	NA	12ft
	NA	28 lbs/acre @8 mph	85 lbs/Acre @8 mph	NA	
Oats	NA	82 lbs/Acre @4 mph	288 lbs/Acre @4 mph	NA	12ft
	NA	41 lbs/Acre @ 8 mph	144 lbs/Acre @ 8 mph	NA	
Red Fescue	NA	53 lbs/Acre @4 mph	NA	NA	7ft
	NA	26 lbs/Acre @8 mph	NA	NA	

- Above Spreader Chart settings are approximate, always trial test applications rate.
- All measurements are taken with the motor spinner at the furthest setting from the deflector shield.
- Formula for calibration of other products not listed above:

$$\frac{\text{Flow Rate (lbs/min)}}{\text{Coverage (Sq-Ft/min)}} \quad \times \quad \frac{\text{lbs/Acre}}{43560 \text{ (sq-ft (1 acre))}}$$

Flow Rate (lbs/min): Material (lbs/min) that flows through selected hopper gate setting per minute.
(Motor and spinner removed with lower mount plate #11)

Coverage (sq-ft/min): Material spread width (Trial test required) multiplied by Distance traveled/min.
(IE 4 mph = 352 ft/min; 3 mph = 264 ft/min; 2 mph = 176 ft/min; 1 mph = 88 ft/min)

HELPFUL TIPS

- Read Owners Manual before use and be sure to follow all safety label cautions provided on the Spreader Hopper.
- Always use **ONLY CLEAN DRY MATERIAL** and be sure to remove all unused material from the hopper after each use. Damp materials will cause material flow problems and material freezing problems in cold temperatures.
- Be sure material is free of foreign matter such as packaging etc.
- Some materials may jam the hopper gate at lower settings so it may be necessary to use a larger setting and increase your MPH to compensate for the increased material flow rate. IE increasing your ground speed from 4Mph to 8Mph will decrease your application rate per acre by half if the same gate setting is used at both speeds.
- Light seed such as Kentucky Blue Grass can be mixed with a seed such as clover to aid in material flow at a 50/50 mix.
- Increased material density per acre can be achieved by adjusting the motor spinner closer to the deflector shield and hopper gate. This accomplishes a narrower spread width providing more pounds/square foot of material.
- Be sure not to attempt spreading light seeds in windy conditions; as poor coverage will result.
- Proper material coverage is achieved with the greatest satisfaction by covering the desired area twice at half the recommended application rate indicated by the manufacturer of the material. Once by traveling length ways then by subsequently by traveling cross ways to account for any underlap issues. The adjustment of the application rate can be made by either adjusting the hopper gate to a lesser setting; or increasing the ground speed of the application vehicle.
- When using the spreader for salt/icemelters/fertilizer or other corrosive materials it is imperative that the spreader is thoroughly cleaned to prevent corrosion causing premature failure of the product.



MANUFACTURING QUALITY LAWN CARE EQUIPMENT SINCE 1945

Owner's Manual

Model Numbers

***Truck
Spreader
11730***



***IMPORTANT
Read and follow all
Safety Precautions
and Instructions
Before Operating this
Equipment.***

***WHEN ORDERING PARTS, PLEASE HAVE THE
FOLLOWING INFORMATION AVAILABLE:***

- * PRODUCT - _____***
- * SERIAL NUMBER - _____***
- * MODEL NUMBER - _____***
- TYPE - _____***
- * PART NUMBER WITH PAINT CODE***
- * PART DESCRIPTION***

TELEPHONE - 1-800-222-8183

FAX - 1-660-747-8650

SWISHER MOWER & MACHINE CO. INC.

1602 CORPORATE DRIVE

WARRENSBURG, MO 64093

swisherinc.com