

CASPER

THE DISAPPEARING SCREENS

CUSTOM-CUTTING INSTRUCTIONS FOR SINGLE AND DOUBLE RETRACTABLE SCREENS

YOU WILL NEED:

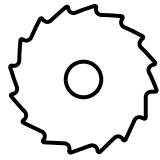

Power Saw **w/Non-Ferrous Metal Blade** Tape Measure Crimping Tool

Included:

Housing w/ mesh and pull bar
x1 for SINGLE door
x2 for DOUBLE doors

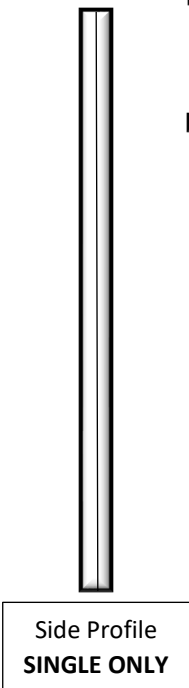
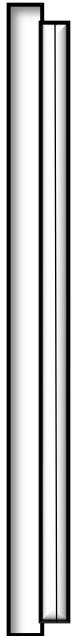

Top Track



Bottom Track

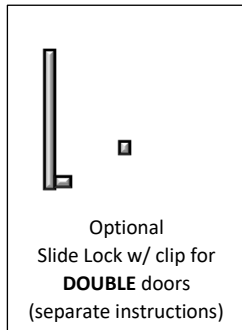

Accessory Pack
x1 for **SINGLE** door
x2 for **DOUBLE** doors
Each Accessory Pack includes the following:
A) Handles x2
B) Boots x2
C) Bearing x1
D) End Cap x1

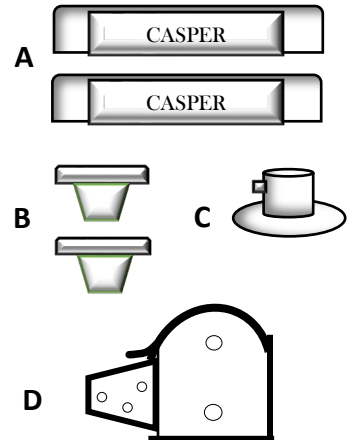



Custom Retractable Screen Measuring Instructions

STEP 1. Casper Disappearing Screens are custom cut and recess-mounted directly into the door jamb. Select a continuous flat surface around the entire door frame inside the door jamb. The surface must have at least 1" of clearance (depth) for the frame housing components to be installed on the hinged side of the door(s). All other sides of the door frame require at least 15/16" clearance (depth) for a trouble-free installation.

STEP 2. Measure the height of door frame's mounting surface to the nearest 1/16". The height should be measured on the hinged side of the door frame. When measuring the height for double doors, if the measurements differ, note both dimensions. If the bottom threshold is sloped, measure to the highest point on the threshold where the screen will mount. (See Diagram 2 where the arrows meet) In this case, you will need wedge shims (not included) to shim the bottom track on the threshold so that it is level.

STEP 3. Measure the width of the door at the TOP and BOTTOM to the nearest 1/16". If these measurements differ, use the SMALLER of the two measurements.

STEP 4. Double check your measurements for accuracy and you are now ready to order your Casper Disappearing Screen!

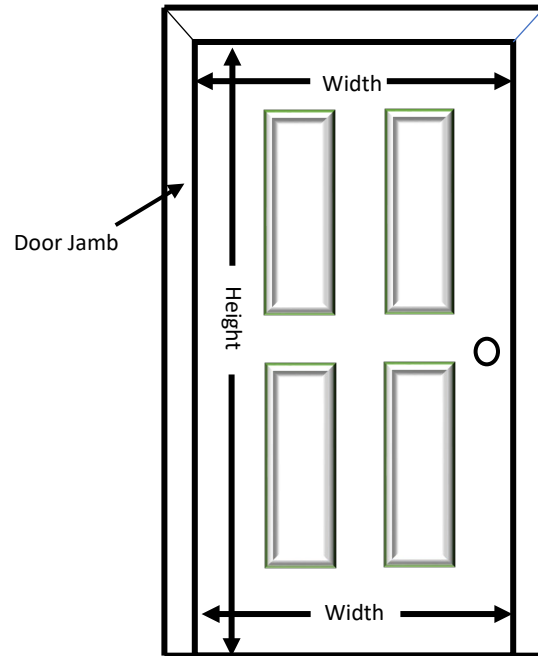

Diagram 1- Single Door

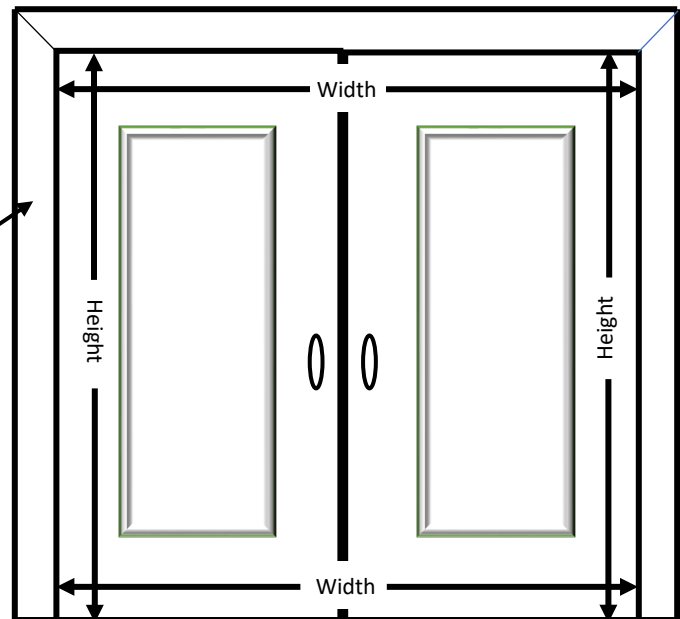

Diagram 3- Double Door

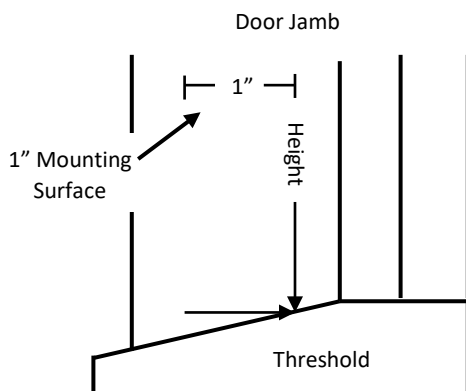



Diagram 2- Threshold Side View

CASPER

THE DISAPPEARING SCREENS

Casper Screens Uncut Dealer Kits Allow You to Easily Custom-Cut the System to Fit Your Single or Double Door Opening. The Kits Come in Several Sizes to Fit Virtually Any Single or Double Door Opening with Custom Sizes Available as Well.

- **BE SURE TO READ THE ENTIRE INSTRUCTIONS BEFORE BEGINNING**
- **DOUBLE CHECK YOUR MEASUREMENTS BEFORE CUTTING TO AVOID ANY MISCUTS, WHICH MAY COMPROMISE THE FIT OF THE SCREEN FRAME**
- **SAFETY GOOGLES ARE ALWAYS REQUIRED WHEN CUTTING TO PREVENT EYE INJURY**
-  **ALWAYS USE CAUTION WHEN OPERATING POWER TOOLS**

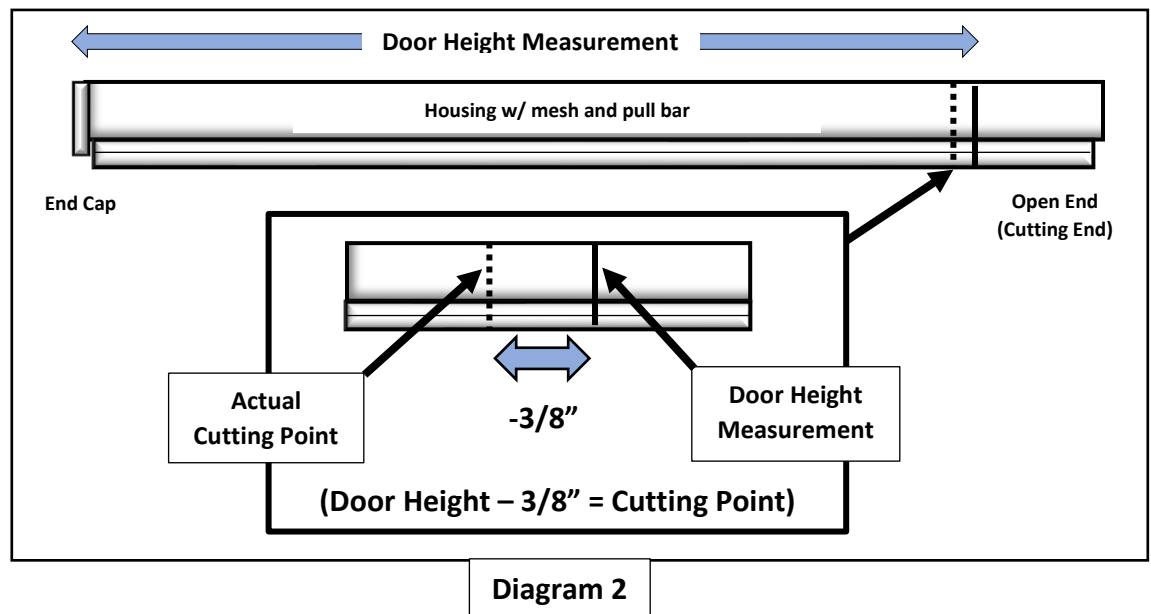
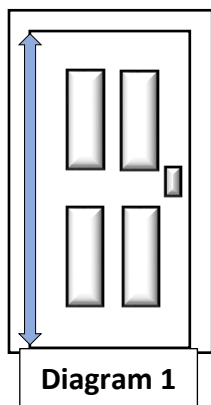

STEP 1. Measure the Height of the Door Opening per our separate measuring instructions. **Do not remove the cellophane wrapping around the center of the housing !** Keeping this in place will secure the pull bar to the housing during the cutting process. Place the housing lying flat with the magnet facing you. The end of the housing with the end cap already in place should always be on your left, this is where the retracting mechanism is located. You will always make the cut on the open end on the right side when facing the housing. The housings are universal, meaning they will fit in either side of the opening.

STEP 2. Using the measurement for the height of the door opening, measure the housing to the same measurement. **Now, subtract 3/8" from that measurement.** This accounts for the 3/8 "width of the end cap which will be installed after cutting. This is the length you will cut the housing. **FOR EXAMPLE, if the height of your opening is 84", after deducting 3/8" the length the housing will be cut is 83 5/8".**

STEP 3. Make your cut using a non-ferrous metal blade through the housing, mesh and pull bar, at a smooth, moderate speed; (Too fast can leave rough edges, too slow can melt the mesh.) Once the cut is made, tap the housing with the open end facing downward to clear out any excess aluminum shavings.

CASPER

THE DISAPPEARING SCREENS

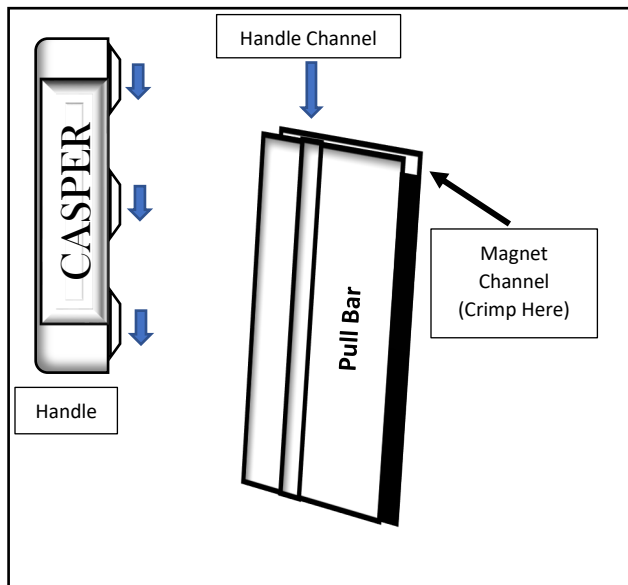

Diagram 3 (Steps 4 & 5)

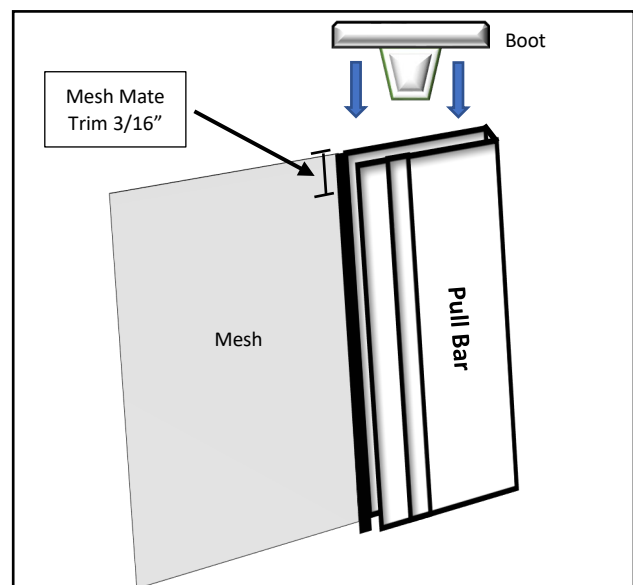

Diagram 4 (Step 6)

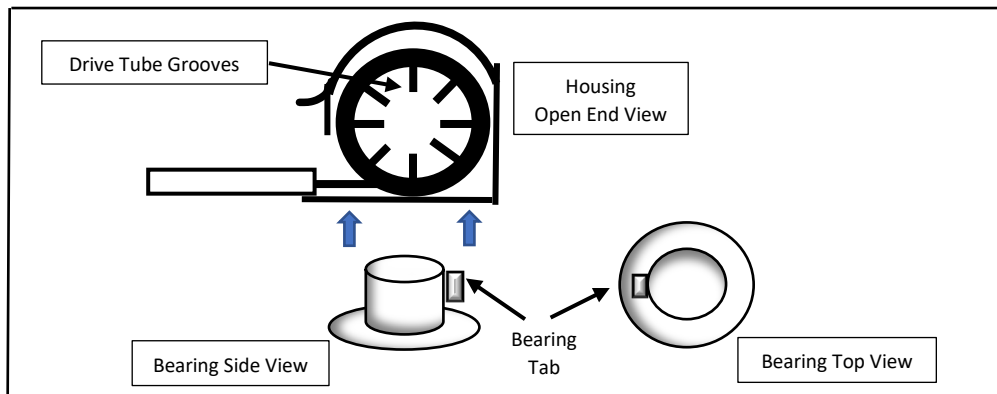

Diagram 5 (Step 7)

STEP 4. With the housing now cut, install the handles by sliding the tabs on each handle into the handle channel on both sides of the pull bar, which is attached to the mesh, **with the Casper logo facing you.** (See Diagram 3) Slide the handles to the center of the housing.

STEP 5. Next, use a crimping tool or pliers to crimp the end of the magnet channel on both ends of the pull bar to ensure the magnet cannot slide out of the channel. (See Diagram 3)

STEP 6. Next, **trim 3/16" from the mesh mate**, the black rubber that connects the mesh to the pull bar, at each end of the pull bar so that you can insert the boots (glides). Insert a boot into each end of the pull bar. You will want to use a crimping tool or pliers to crimp the end of the pull bar slightly, **BEFORE** inserting the boot to ensure a snug fit to prevent them from coming loose during use. (See Diagram 4)

STEP 7. Next, insert the bearing into the drive tube on the open end of the housing. Be sure that the tab on the bearing fits securely into one of the grooves on the drive tube. **IT IS ESPECIALLY IMPORTANT FOR THE TAB BE PROPERLY IN THE GROOVE FOR PROPER OPERATION.** (See Diagram 5)

CASPER

THE DISAPPEARING SCREENS

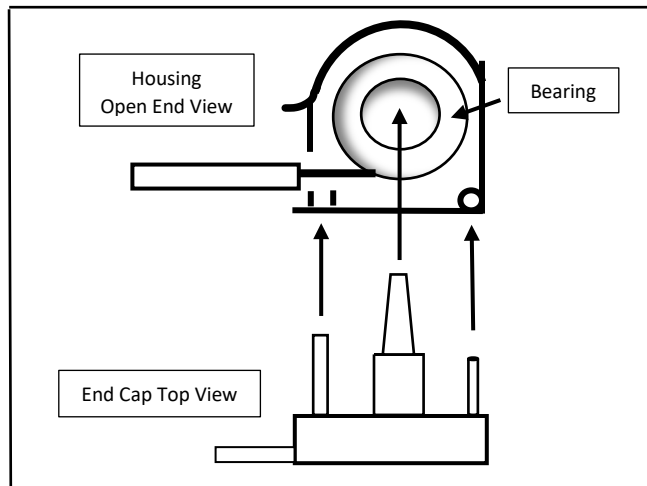

Diagram 6 (Step 8)

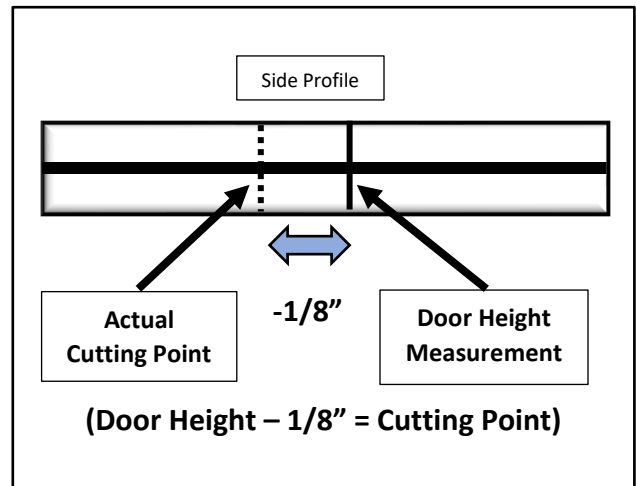

Diagram 7 (Step 9)

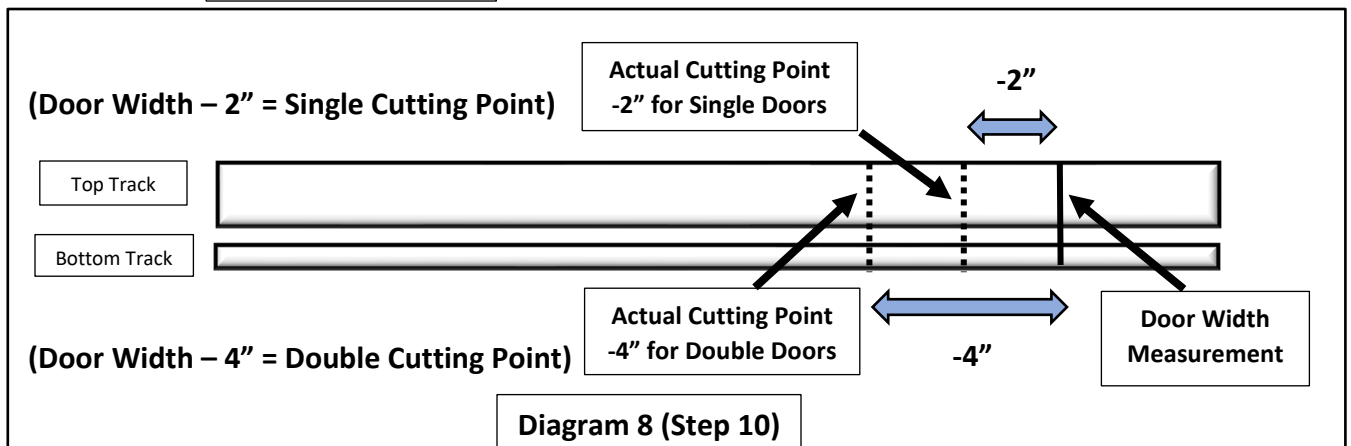

Diagram 8 (Step 10)

STEP 8. Next, insert the end cap through the bearing and secure the end cap into the drive tube by fitting the two prongs on the end cap into the corresponding channels on the housing. (See Diagram 6) Lightly tap on the end cap to secure it tightly. Now your housing is ready to be tested by extending the mesh out and ensuring that it properly retracts. **If you are installing a double screen, you will have two housings, so repeat this process for the opposite side housing. You will not need a side profile.**

STEP 9. Next, if you are cutting a **SINGLE DOOR** you will have one housing and a side profile with magnet. Using the door height measurement used in **STEP 2**, measure the side profile to same measurement. **Now, subtract 1/8" from that measurement.** Your result will be the length of the side profile and where you will make your cut. **FOR EXAMPLE,** If the height measurement is 84", after deducting 1/8" the length the side profile will be cut is 83 7/8".

STEP 10. Finally, Using the width of the opening per the measuring Instructions, measure the top and bottom tracks to this measurement. **If you are cutting for a single door, subtract 2 inches from the width. For double doors, you will subtract four inches off the width.** This is to account for the width of the housings and allows the frame to fit nicely into the door opening. For **sliding doors** you should make **NO DEDUCTIONS on the tracks** as the housing will mount flush to the stationary panel. Use this measurement to make your cut. Once the top and bottom tracks are cut, crimp both edges of the brush channels on the newly cut end of the tracks to prevent the top and bottom track brushes from sliding out. Now your Casper Disappearing Screen kit is ready to install per our Installation Instructions.