

# Oil Barrel Roller Cart Instructions



Picture 1



Picture 2



Picture 3



Picture 4



Picture 4-1    Picture 4-2    Picture 4-3

- 1.You can handle and store this drum cart upright, in pushing position. ( Picture 1 )
- 2.Drum cart handles hinges outward to give added leverage for easier moving and steering. ( Picture 2 )
- 3.Easily transport 55 gallon steel or plastic drums.
4. The handle is with the speical drum multifunctional wrenches. ( Picture 3 )
- 5.Could be easy to drag the cart with barrel forward. ( Picture 4 )
6. Could push the cart forwarder. (Picture 5 & Picture 5-1)

Model		W2019P231510
Rated load capacity	lbs	1102
Net weight	lbs	38.6
Wheel Dimension	inch	2X6" and 1X3"

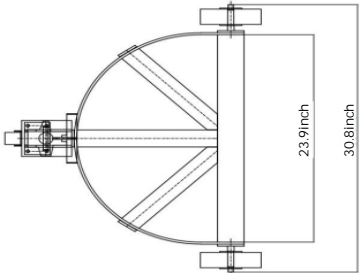
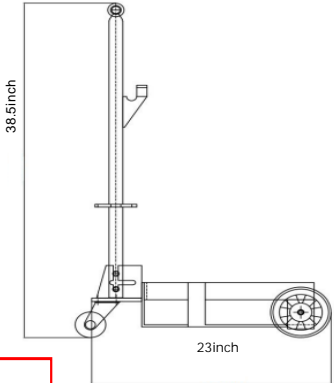

## Caution !

Should put on the work shose while use this cart to load and move any container in order to protect you from the dangerous and be harmed.



Picture 5

Picture 5-1