

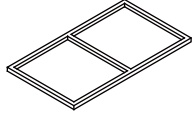

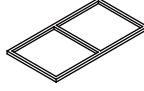

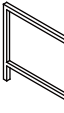

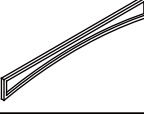

ASSEMBLY INSTRUCTION

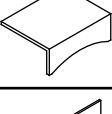
PACKING LIST

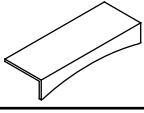
A	TABLE TOP		1PC
B	TABLE SHELF		1PC
C	TABLE ARM		2PCS
D	SUPPORT CHIP		2PCS
E	CHAIR BACK		2PCS
F	LEFT ARM		3PCS
G	SEAT FRAME		2PCS
H	CHAIR BACK		1PC
I	RIGHT ARM		3PCS
J	SEAT FRAME		1PC
K	BOLT	 M6x30mm	49PCS
M	METAL WASHER		49PCS
N	ALLEN WRENCH		1PC

COFFEE TABLE

STEP1

Connect A and C, with bolt(K) metal washer(M) and allen wrench(N)

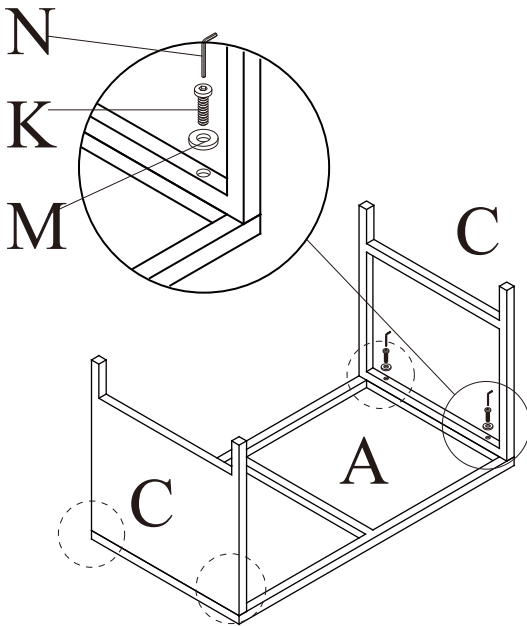

STEP2

Connect B and C, with bolt(K) metal washer(M) and allen wrench(N)

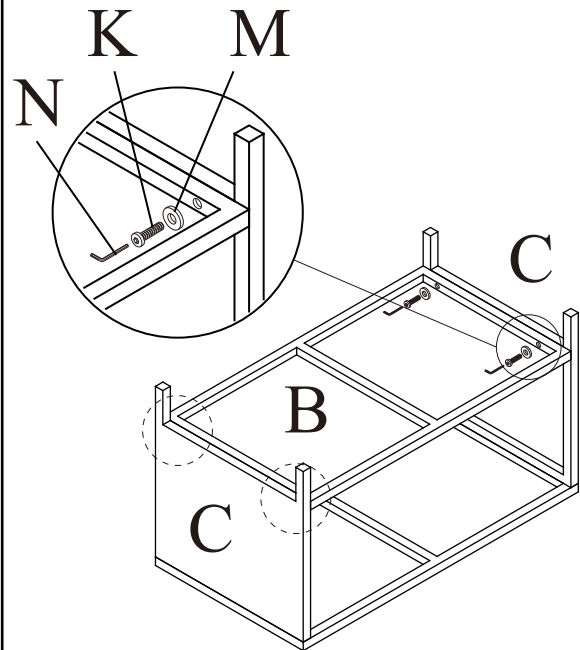

STEP3

Connect D and A,C with bolt (K), metal washer (M),and allen wrench (N).

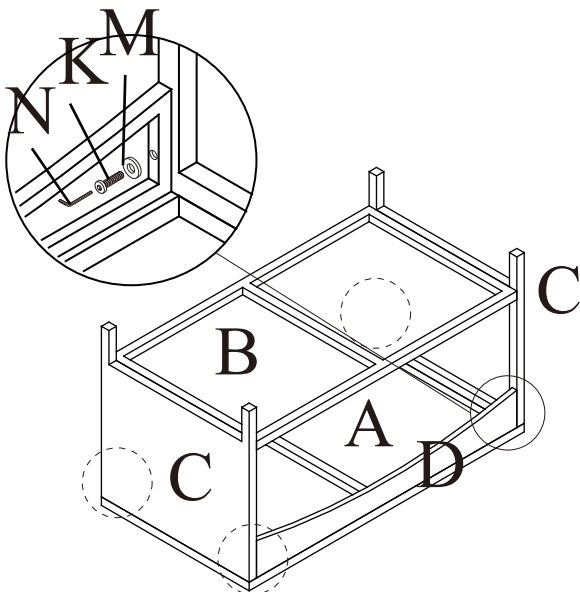

STEP4

Finished

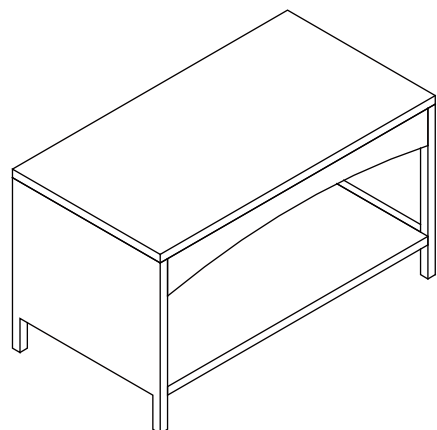

SINGLE CHAIR

STEP1

Connect G and F(I), with bolt(K), washer(M) and allen wrench(N)

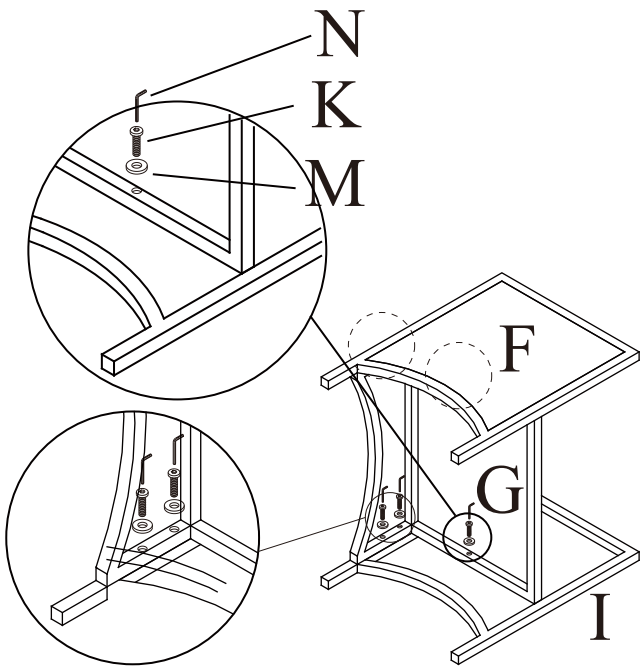

STEP2

Connect E and F(I,G), with bolt(K), metal washer(M) and allen wrench(N)

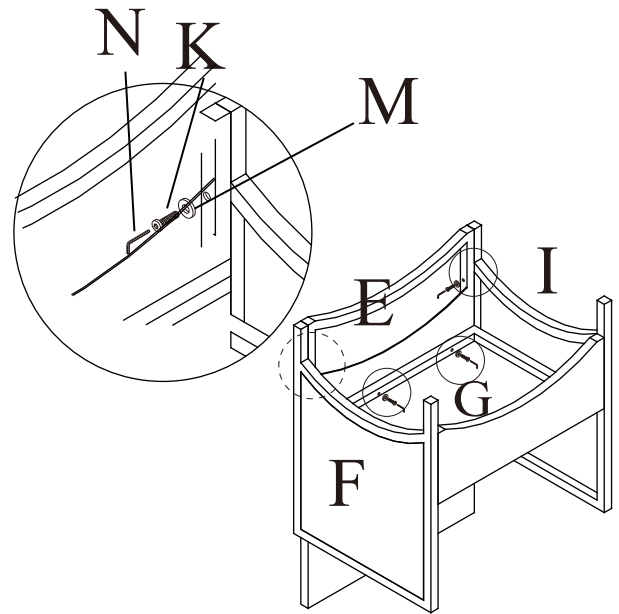

STEP3

Connect E and F(I), with bolt(K), metal washer(M) and allen wrench(N)

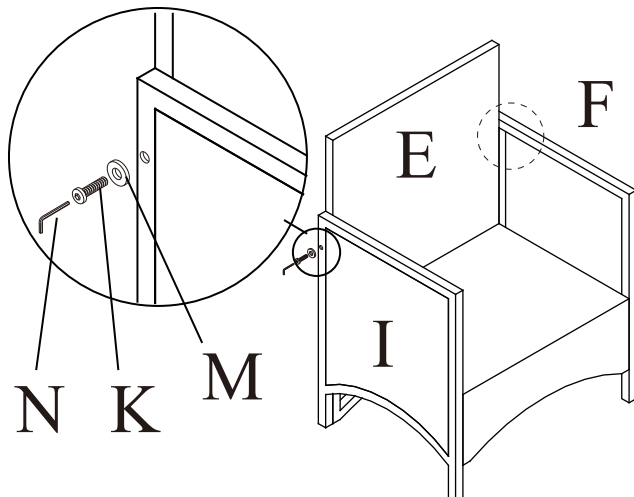

STEP4

Finished

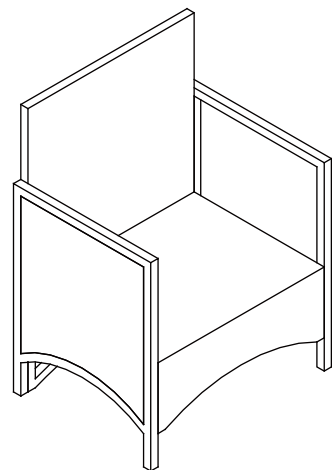

LOVE CHAIR

STEP1

Connect J and I(F), with bolt(K) metal washer(M) and allen wrench(N),

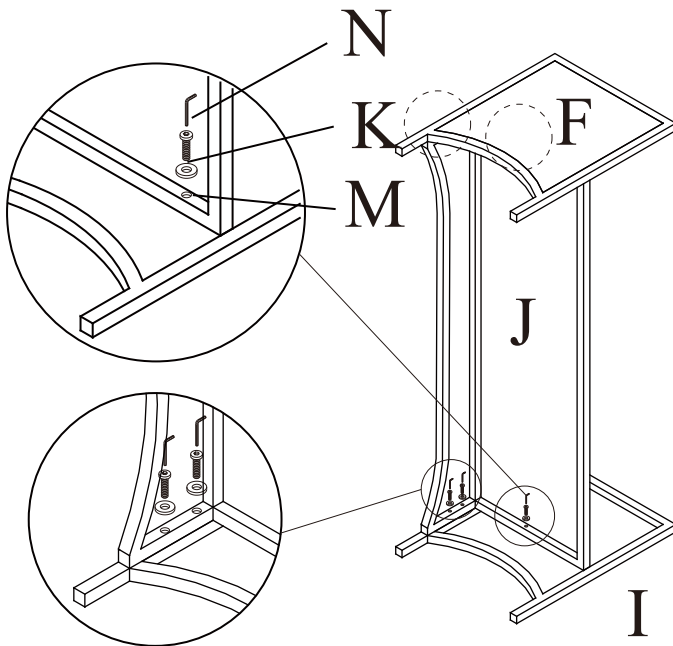

STEP2

Connect H and F(I,J) with bolt(K), metal washer(M) and allen wrench(N)

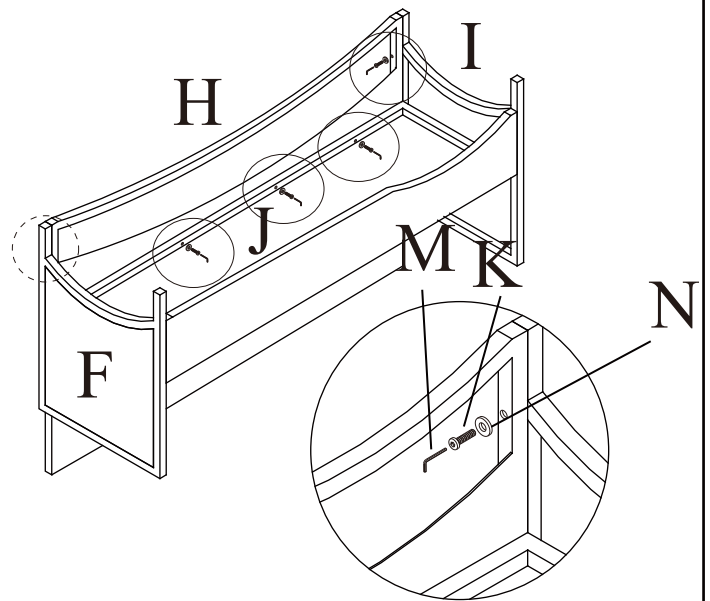

STEP3

Connect H and I(F), with bolt(K) metal washer(M) and allen wrench(N)

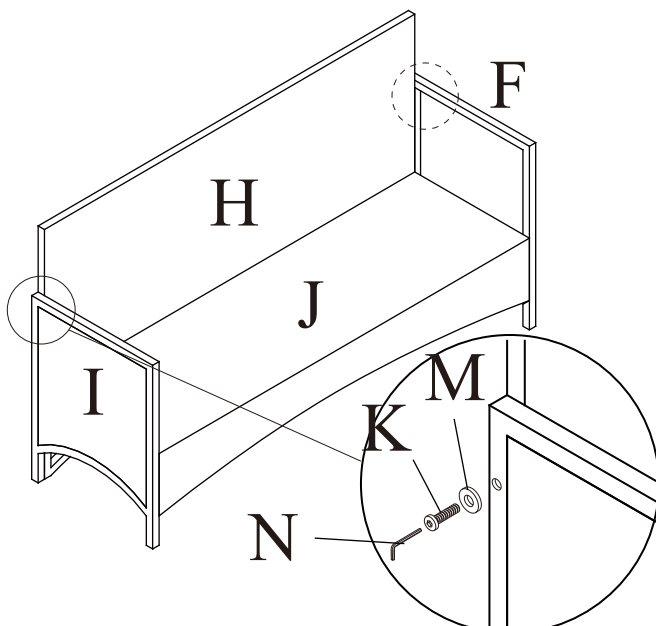

STEP4

Finished

