



PREMIUM HOME SOLUTION

VALUABLE
DURABLE
ENJOYABLE

BELIEVE
WHAT
YOU GET
Believe What
You Get

USE AND CARE GUIDE

E02GF149-N



Questions, problems, missing parts? Before returning to the store please contact our Customer Service

• service@alphamarts.com •

THANK YOU

We appreciate the trust and confidence you have placed in us through the purchase of our product. We strive to continually create quality products designed to enhance your home. Visit us online to see our full line of products available for your home improvement needs. Thank you for choosing us!

Scan me to see more
assemble videos about
the product



SKU:E02GF149-N

Table of Contents

Table of Contents	2	Pre-assembly	3
Safety Information	2	Assembly	4-5
Warranty	2	Care And Maintenance	6
What is Covered	2		
What is Not Covered	2		

Safety Information

- **Do not completely tighten screws until all screws are started.** Tighten each bolt firmly and properly.
- Some parts may contain sharp edges. Wear protective gloves as necessary.
- Children under the age of 16 should not be engaged in the assembly, removal or disassembly of the product. Children under the age of 10 should be supervised by a competent adult while using this furniture.
- Please keep children out of the assembly area.
- This set is heavy, and may require two adults for safe assembly.
- Never use this product as a support. Do not shake, lean, or climb on the product at any time.



DANGER : Do not allow children to play with plastic wraps or small parts to prevent potential choking hazard.



CAUTION: Read all the instructions before assembly. Failure to do so may result in faulty assembly and potential injury!

Warranty

LIMITED WARRANTY

This warranty is a limited warranty, and applies to the original purchase is required. This is a residential warranty and does not apply to commercial use. This collection carries a (1) year limited warranty and is valid from original date of purchase to the original owner (proof of purchase required).

WHAT IS COVERED

We warrant the frame to be free of Manufacturing defects to the original purchaser for one year.

WHAT IS NOT COVERED

This warranty does not cover commercial use, hardware, acts of nature, fire, freezing and abusive.

In addition, purchased parts are not covered under this warranty.

We reserve the right to make substitutions with similar merchandise, if the model in question is no longer in production.

For a copy of our full limited warranty, please contact our customer service team.

Pre-assembly (continued)

Assemble the item on a soft, non-abrasive surface, such as carpet or cardboard to avoid damaging the item. Seek assistance to assemble bulky or heavy items.



NOTE: Identify all parts packed in the carton against the parts list. Remove all the protective material carefully and DO NOT use a knife to prevent scratching the furniture.

PACKAGE CONTENTS



NOTE: Hardware not shown to actual size.

Part	Quantity	Picture	Part	Quantity	Picture
A	1	 Refer to the red circles for screw hole position	B	1	 Refer to the red circles for screw hole position
C	1		D	1	
J	1		K	1	

Part	Quantity	Description	Picture
E	4	M6 X 30mm Bolt	
F	4	M6 X 25mm Bolt	
G	8	M6 Metal Washer	
H	8	M6 Spring Washer	
I	1	M6 Hex Wrench	

Please note that this package contains sponges but does not include a fabric shell. The shell is shipped separately in another package and needs to be installed by the customer. If you have not received it at the same time, please be patient and wait. Thank you.

Assembly

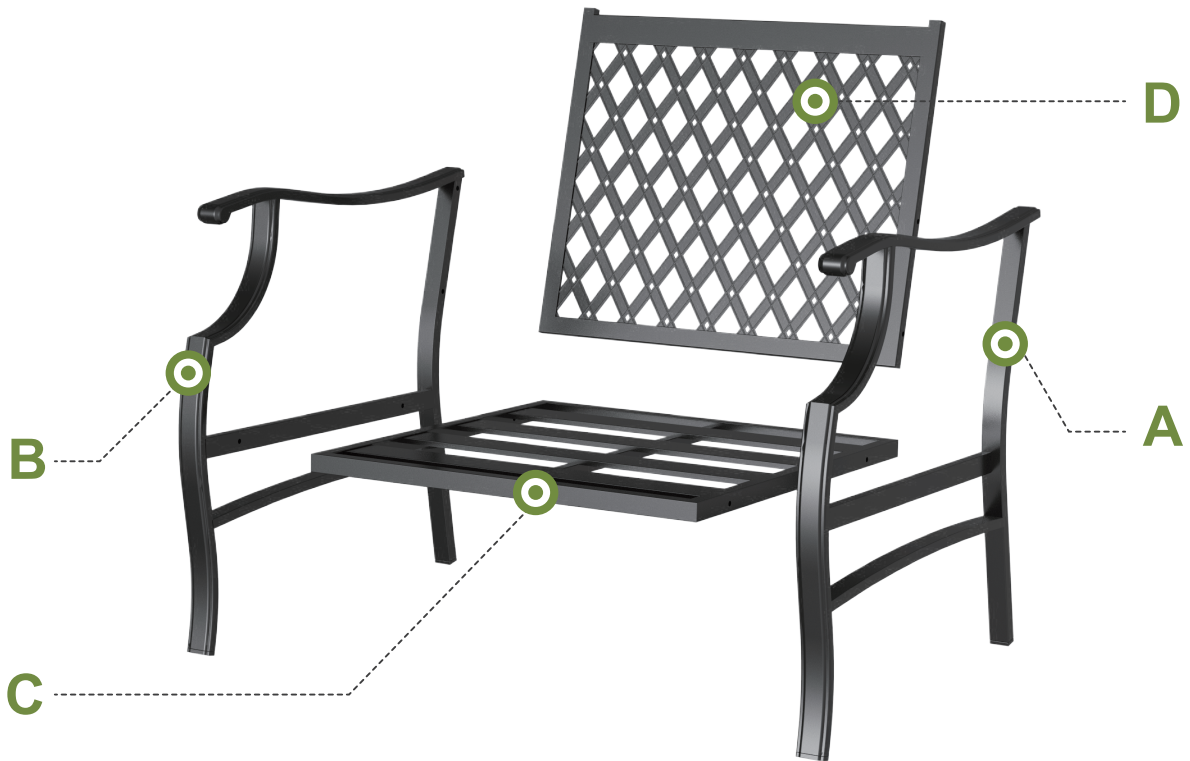

Do not tighten any screws until all the screws have been inserted into their holes; otherwise, it may cause some holes to misalign.

Step 1

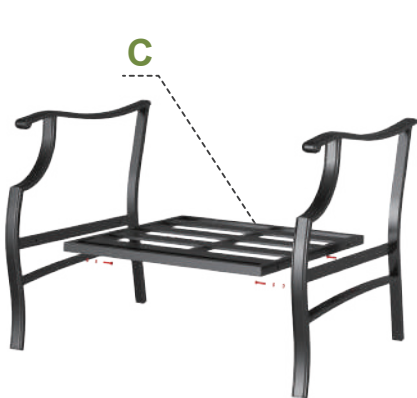

Before

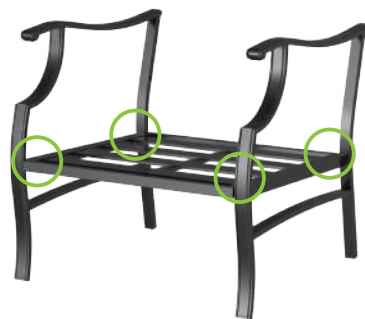

After

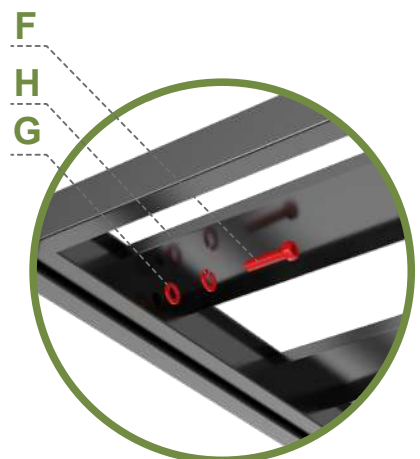

Detail

Assembly

Step 2



Before



After

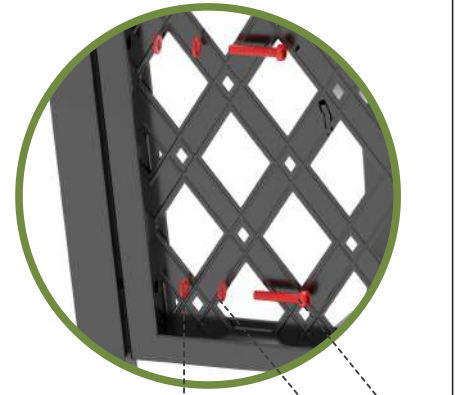

Detail
G H E

Step 3



Before

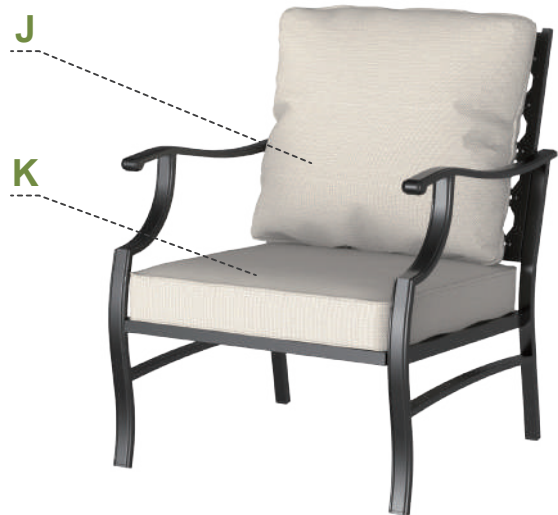

After
J K

Cleaning and Maintenance

- Clean the furniture with damp cloth, rinse thoroughly. Dry frame parts completely. Do not use bleach, acid or other solvents on the textile or metal parts.
- We recommend the use of furniture covers to protect the product when not in use.
- Inspect and tighten all screws on a regular basis to ensure proper performance and safety.
- In order to prolong the life and beauty of your product, we recommend storing it in a dry and protected area during off season periods.



**Questions, problems, missing parts? Before returning to the store
please contact our Customer Service**

• **service@alphamarts.com** •

1-877-606-2818



PREMIUM HOME SOLUTION



USE AND CARE GUIDE

E02GF152-N



Questions, problems, missing parts? Before returning to the store please contact our Customer Service

• service@alphamarts.com •

THANK YOU

We appreciate the trust and confidence you have placed in us through the purchase of our product. We strive to continually create quality products designed to enhance your home. Visit us online to see our full line of products available for your home improvement needs. Thank you for choosing us!

Scan me to see more assemble videos about the product



SKU:E02GF152-N

Table of Contents

Table of Contents	2	Pre-assembly	3-4
Safety Information	2	Assembly	5-8
Warranty	2	Care And Maintenance	9
What is Covered	2		
What is Not Covered	2		

Safety Information

- **Do not completely tighten screws until all screws are started.** Tighten each bolt firmly and properly.
- Some parts may contain sharp edges. Wear protective gloves as necessary.
- Children under the age of 16 should not be engaged in the assembly, removal or disassembly of the product. Children under the age of 10 should be supervised by a competent adult while using this furniture.
- Please keep children out of the assembly area.
- This set is heavy, and may require two adults for safe assembly.
- Never use this product as a support. Do not shake, lean, or climb on the product at any time.



DANGER : Do not allow children to play with plastic wraps or small parts to prevent potential choking hazard.



CAUTION: Read all the instructions before assembly. Failure to do so may result in faulty assembly and potential injury!

Warranty

LIMITED WARRANTY

This warranty is a limited warranty, and applies to the original purchase is required. This is a residential warranty and does not apply to commercial use. This collection carries a (1) year limited warranty and is valid from original date of purchase to the original owner (proof of purchase required).

WHAT IS COVERED

We warrant the frame to be free of Manufacturing defects to the original purchaser for one year.

WHAT IS NOT COVERED

This warranty does not cover commercial use, hardware, acts of nature, fire, freezing and abusive.

In addition, purchased parts are not covered under this warranty.

We reserve the right to make substitutions with similar merchandise, if the model in question is no longer in production.

For a copy of our full limited warranty, please contact our customer service team.

Pre-assembly (continued)

Assemble the item on a soft, non-abrasive surface, such as carpet or cardboard to avoid damaging the item. Seek assistance to assemble bulky or heavy items.



NOTE: Identify all parts packed in the carton against the parts list. Remove all the protective material carefully and DO NOT use a knife to prevent scratching the furniture.

PACKAGE CONTENTS



NOTE: Hardware not shown to actual size.

Part	Quantity	Picture	Part	Quantity	Picture
A	1	 Refer to the red circles for screw hole position	B	1	 Refer to the red circles for screw hole position
C	1	 Refer to the red circles for screw hole position	D	1	 Refer to the red circles for screw hole position
E	1	 Refer to the red circles for screw hole position	F	1	 Refer to the red circles for screw hole position
G	1		H	2	
S	3		T	3	

Please note that this package contains sponges but does not include a fabric shell. The shell is shipped separately in another package and needs to be installed by the customer. If you have not received it at the same time, please be patient and wait. Thank you.

Pre-assembly(continued)

Assemble the item on a soft, non-abrasive surface, such as carpet or cardboard to avoid damaging the item. Seek assistance to assemble bulky or heavy items.



NOTE: Identify all parts packed in the carton against the parts list.
Remove all the protective material carefully and DO NOT use a knife to prevent scratching the furniture.

HARDWARE PACK



NOTE: Hardware not shown to actual size.

Part	Quantity	Description	Picture
I	2	M6 X 52mm Bolt	
J	4	M6 X 30mm Bolt	
K	4	M6 X 25mm Bolt	
L	10	M6 X 18mm Bolt	
M	2	M6 X 48mm Bolt	
N	28	M6 Metal Washer	
O	24	M6 Spring Washer	
P	4	M6 Nut	
Q	1	M6 Hex Wrench	
R	1	M6 Wrench	

Assembly

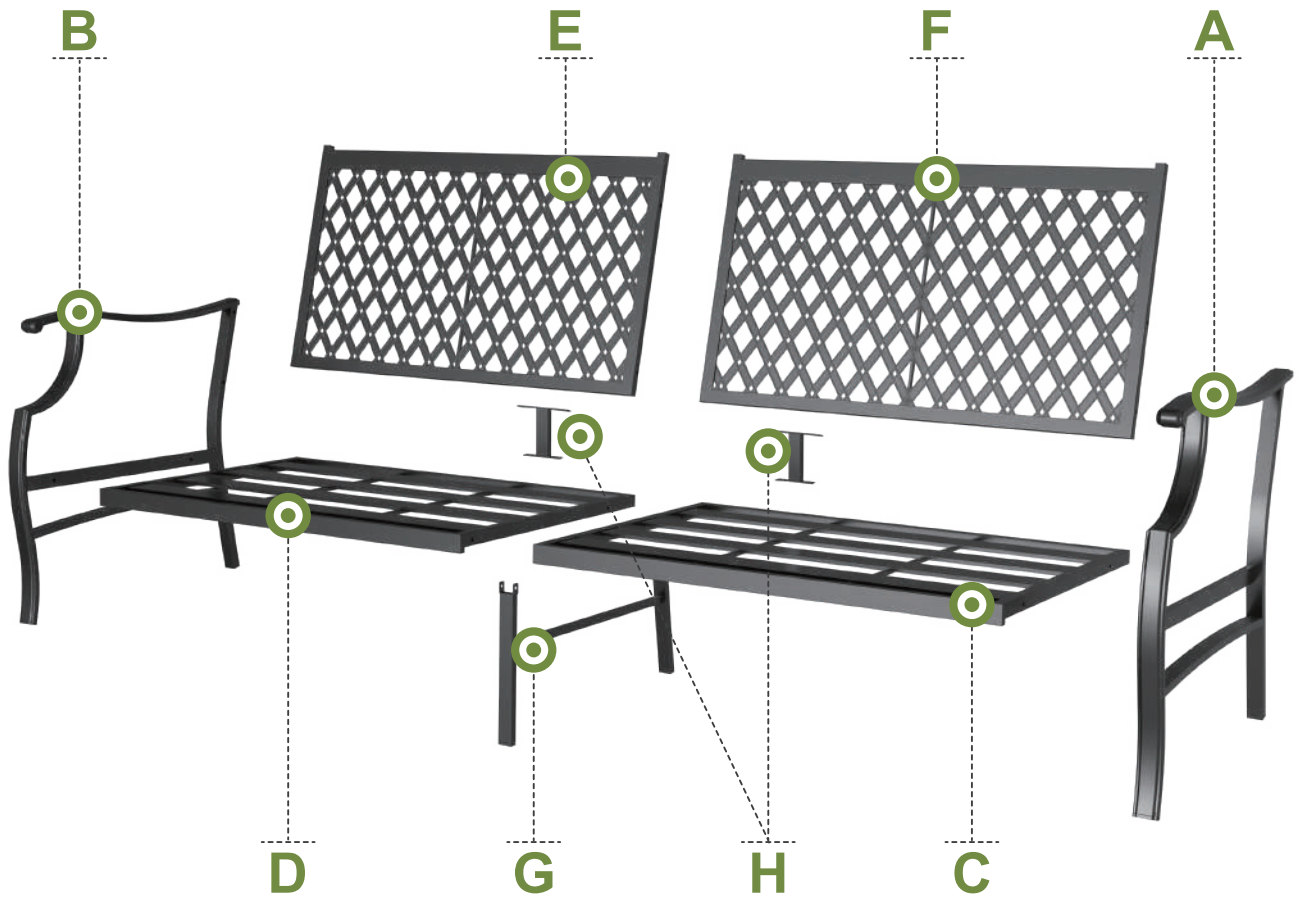

Do not tighten any screws until all the screws have been inserted into their holes; otherwise, it may cause some holes to misalign.

Step 1

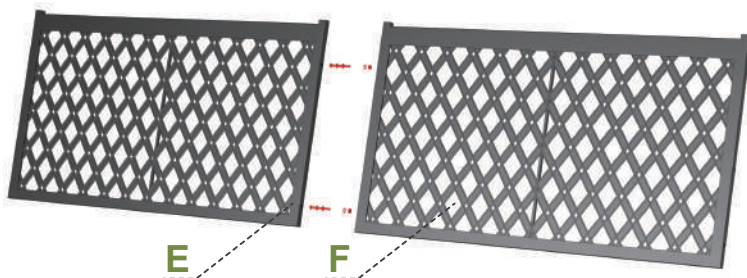

Before

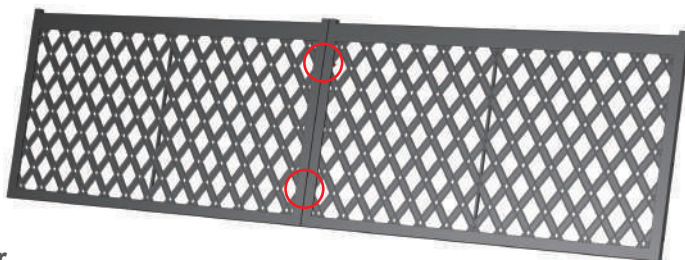

After

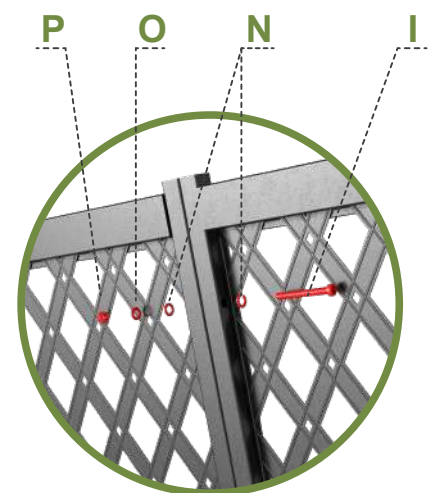

Detail

Assembly

Step 2

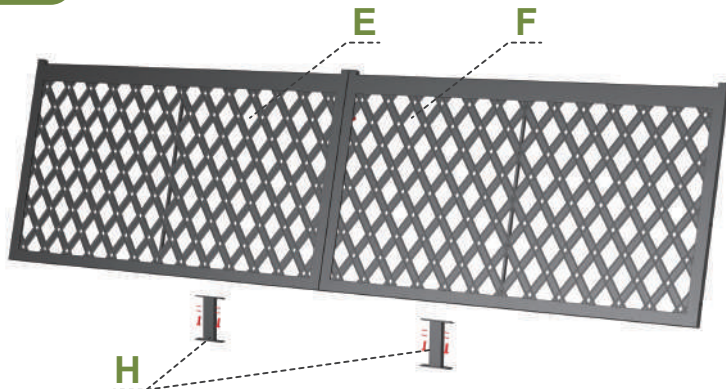

Before

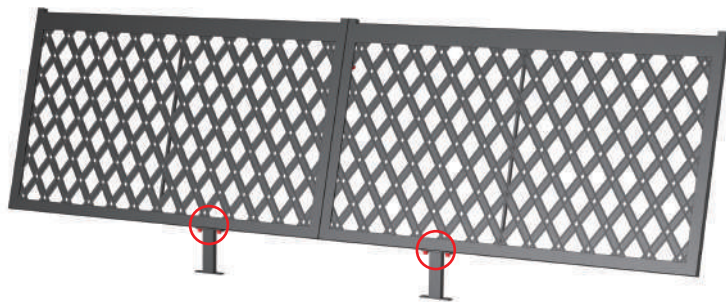

After

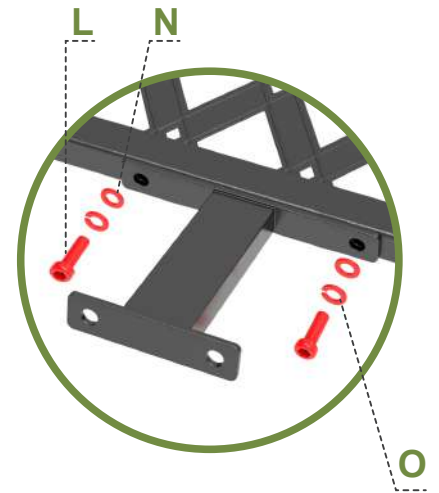

Detail

Step 3

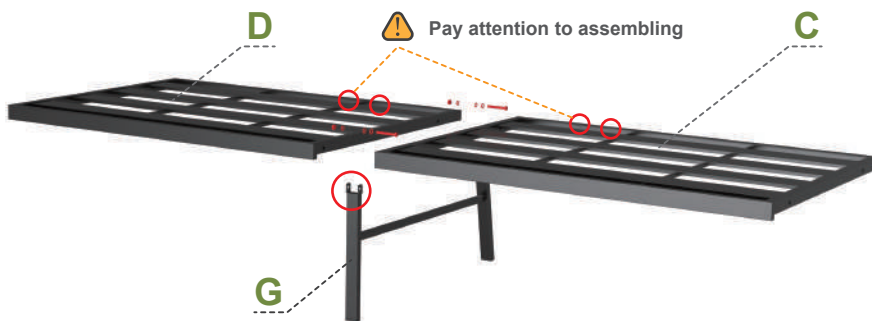

Before



After

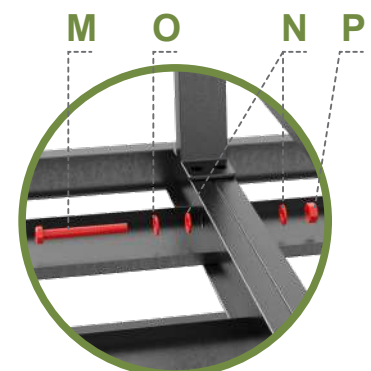
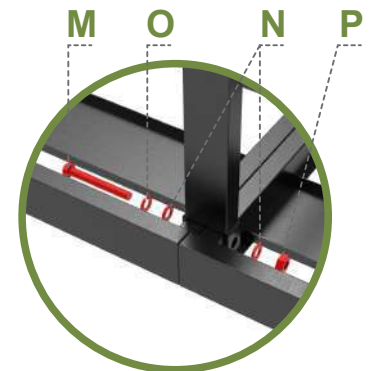

Detail

Assembly

Step 4

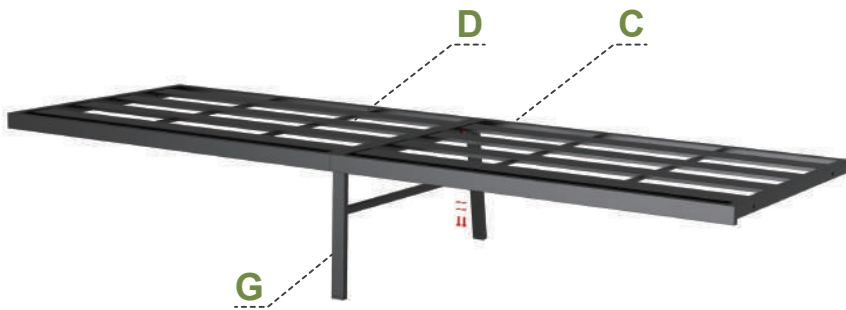

Before



After

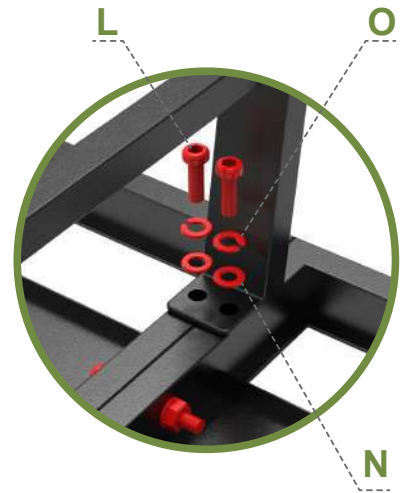

Detail

Step 5



Before



After

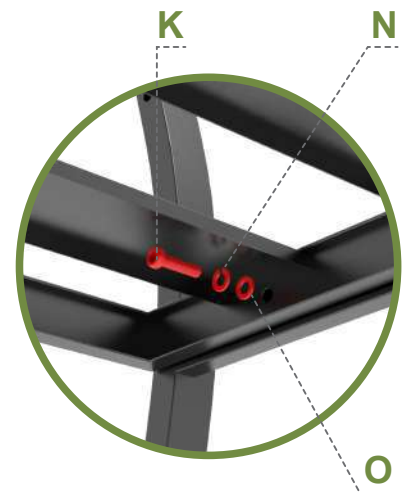

Detail

Assembly

Step 6



Before



After

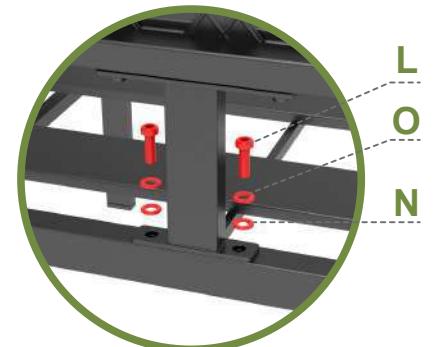
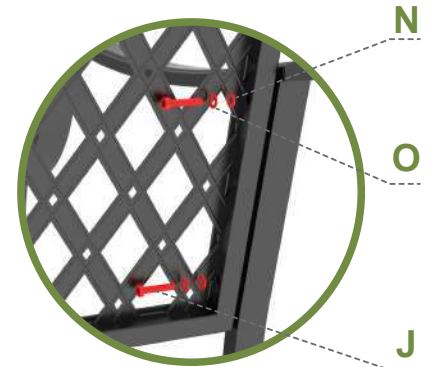

Detail

Step 7



Before



After

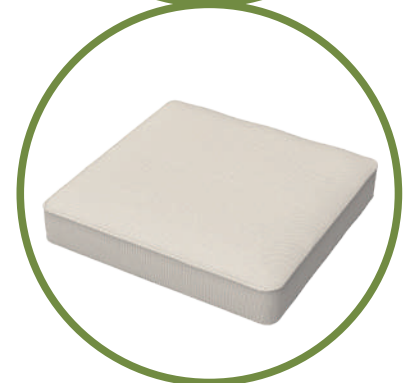

Detail

Cleaning and Maintenance

- Clean the furniture with damp cloth, rinse thoroughly. Dry frame parts completely. Do not use bleach, acid or other solvents on the textile or metal parts.
- We recommend the use of furniture covers to protect the product when not in use.
- Inspect and tighten all screws on a regular basis to ensure proper performance and safety.
- In order to prolong the life and beauty of your product, we recommend storing it in a dry and protected area during off season periods.



**Questions, problems, missing parts? Before returning to the store
please contact our Customer Service**

• service@alphamarts.com •

1-877-606-2818



PREMIUM HOME SOLUTION

VALUABLE
DURABLE
ENJOYABLE

BELIEVE
WHAT
YOU GET
Believe What
You Get

USE AND CARE GUIDE

E02GS007-YM



Questions, problems, missing parts? Before returning to the store please contact our Customer Service

• service@alphamarts.com •

THANK YOU

We appreciate the trust and confidence you have placed in us through the purchase of our product. We strive to continually create quality products designed to enhance your home. Visit us online to see our full line of products available for your home improvement needs. Thank you for choosing us!

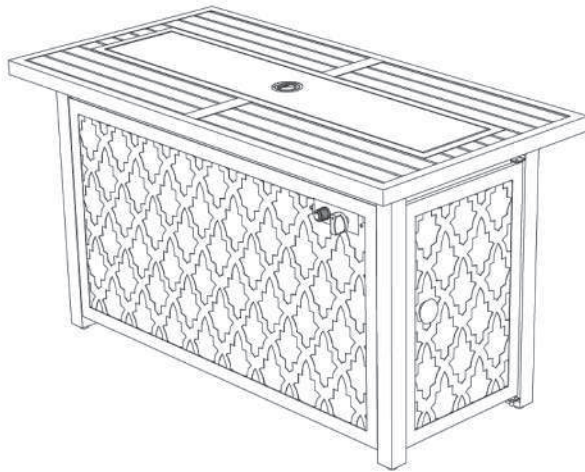

⚠ DANGER • FLAMMABLE GAS UNDER PRESSURE.
LEAKING LP-GAS MAY CAUSE A FIRE OR EXPLOSION IF IGNITED
CAUSING SERIOUS BODILY INJURY OR DEATH.
CONTACT LP GAS SUPPLIER FOR REPAIRS, OR DISPOSAL OF THIS
CYLINDER OR UNUSED LP-GAS.

⚠ WARNING • FOR OUTDOOR USE ONLY.*
DO NOT USE OR STORE CYLINDER IN A BUILDING,
GARAGE OR ENCLOSED AREA.

⚠ WARNING:

- Know the odor of LP-gas. If you hear, see or smell leaking LP-gas, immediately get everyone away from the cylinder and call the Fire Department. Do not attempt repairs.
- Caution your LP-gas supplier to:
 - Be certain cylinder is purged of trapped air prior to first filling.
 - Be certain not to over fill the cylinder.
 - Be certain cylinder requalification date is checked.
- LP-gas is heavier than air and may settle in low places when dissipating.
- Contact with the liquid contents of cylinder will cause freeze burns to the skin.
- Do not allow children to tamper or play with cylinder.
- When not connected for use, keep cylinder valve turned off. Self contained appliances shall be limited to a cylinder of 30 lb capacity or less.
- Do not use, store or transport cylinder where it would be exposed to high temperatures. Relief valve may open allowing a large amount of flammable gas to escape.
- When transporting, keep cylinder secured in an upright position which cylinder valve turned off.

WHEN CONNECTING FOR USE:

- Use only in compliance with applicable codes.
- Read and follow manufacturer's instructions.
- Consult manufacturer's instructions concerning the cylinder connection provided with your appliance.
- Do not check for gas leaks with a match or open flame. Apply soapy water at areas marked "X". Open cylinder valve. If bubble appears, close valve and have LP-gas service person make needed repairs. Also, check appliance valves and connections to make sure they do not leak before lighting appliance.
- Light appliance(s) following manufacturer's instructions.
- When appliance is not in use, keep the cylinder valve closed.

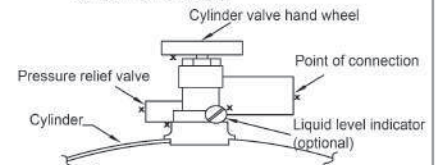

DO NOT REMOVE, DEFACE, OR OBLITERATE THIS LABEL
***EXCEPT AS AUTHORIZED BY ANSI/NFPA 58.**

- ⚠ DANGER.** Do not store a spare LP cylinder under or near a barbecue grill, or other heat sources. NEVER fill an LP cylinder beyond 80% full: a fire causing death or serious injury may occur.



Please keep this instruction manual for future reference

⚠ WARNING

READ INSTRUCTION MANUAL BEFORE ATTEMPTING ASSEMBLE OR
OPERATE THIS PRODUCT.

Keep the screws and parts out of reach of children.
(Made in China)

Table of Contents

Table of Contents	2	Operating Instructions	11-13
Safety Information.....	2-4	Maintenance.....	14
Pre-Assembly.....	5	Care and Cleaning	14
Package Contents.....	6	Troubleshooting	15
Assembly.....	8-10		

Safety Information

Read the instruction before use. This appliance must be installed in accordance with such regulations as are enforced.

⚠ DANGER:
FIRE OR EXPLOSION HAZARD

If you smell gas:

- Shut off gas to the appliance.
- Extinguish any open flame.
- If odor continues, leave the area immediately
- After leaving the area, call your gas supplier or fire department.

Failure to follow these instructions could result in fire or explosion, which could cause property damage, personal injury, or death.

⚠ WARNING: For Outdoor Use Only!

Installation and service must be performed by a qualified installer, service agency, or the gas supplier

⚠ WARNING:

Improper installation, adjustment, alteration, service or maintenance can cause property damage, personal injury or loss of life. Read this installation, operating, and maintenance instructions thoroughly before installing or servicing this equipment.

⚠ DANGER	CARBON MONOXIDE HAZARD
	This appliance can produce carbon monoxide which has no odor.
	Using it in an enclosed space can kill you.
	Never use this appliance in an enclosed space such as a camper, tent, car or home.

⚠ WARNING:

FOR YOUR SAFETY:

If the information in this manual is not followed exactly, a fire or explosion may result causing property damage, personal injury or loss of life.

WHAT TO DO IF YOU SMELL GAS:
 Do not try lighting any appliance.
 Do not touch any electrical switch; do NOT use any phone in your building.
 Immediately call your gas supplier from a neighbor's phone.
 Follow the gas supplier's instructions.
 If you cannot reach your gas supplier. Call the fire department.
 Installation and service must be performed by a qualified installer, service agency or gas supplier. Save these instructions for future reference. If you are assembling this unit for someone else, give this manual to him or her to read and save for future reference.

⚠ WARNING:

Do not store or use gasoline, or other flammable vapors and liquids, in the vicinity of this or any other appliance. An LP-cylinder not connected for use shall not be stored in the vicinity of this or any other appliance.

INSTALLER: leave this manual with the appliance.
CONSUMER: Retain this manual for future reference.

Safety Information (continued)



WARNING:

You must provide propane gas and propane cylinder. Use a standard 20 lb. propane cylinder only.

Use this heater only with a propane vapor withdrawal supply system. See Chapter 5 of the Standard for Storage and Handling of Liquefied Petroleum Gas, ANS/NFPA 58. Your local library or fire department should have this book.

The pressure regulator and hose assembly supplied with the appliance must be used.

The installation must conform with local codes, or in absence of local codes, with National Fuel Gas Code, ANSI Z223.1.

A dented, rusted, or damaged propane cylinder may be hazardous and should be checked by your cylinder supplier. Never use a propane cylinder with a damaged valve connection.

The LP-gas supply cylinder must be constructed and marked in accordance with the U.S. Department of Transportation (D.O.T) Specifications for LP-Gas Cylinders, or the standard for Cylinders, Spheres and Tubes for Transportation of Dangerous Good and Commission, CAN/CSA-B339, as applicable.

The LP-gas supply cylinder must be provided with a cylinder connection device compatible with the connection for the appliance.

The cylinder used must include a collar to protect the cylinder valve.

The LP-gas supply cylinder must be provided with a listed overfill protection device (OPD).

Do not store a spare LP gas cylinder under or near this appliance.

Never fill the cylinder beyond 80 percent full.

For appliances designed to use a CGA No. 791IQCC connection.

Place the dust cap on the cylinder valve outlet whenever the cylinder is not in use.

Note: Gas supply pressure: 25 PSI to 250 PSI.



Standard 20 lbs. tank



WARNING: FUELS USED IN LIQUIFIED PROPANE GAS APPLIANCES, AND THE PRODUCTS OF COMBUSTION OF SUCH FUELS, CAN EXPOSE YOU TO CHEMICALS INCLUDING BENZENE, WHICH IS KNOWN TO THE STATE OF CALIFORNIA TO CAUSE CANCER AND CAUSE BIRTH DEFECTS OR OTHER REPRODUCTIVE HARM. For more information go to: www.P65Warnings.ca.gov.

Safety Information (continued)



WARNING:

Solid fuels shall not be burned in this appliance.

The installation must conform with local codes or, in the absence of local codes, ANSIZ223. 1/NFPA54, NFPA58 Natural Gas and Propane Installation Code, CSA B149.1, or Propane Storage and Handling Code, B149.2.

This appliance must be isolated from the gas supply piping system by closing its individual manual shutoff valve during any pressure testing of the gas supply piping system at test pressures equal to or less than 1/2 psi (3.5 kPa).

Max. gas supply 6791.3 in wc (1725 kPa). Manifold pressure 11 in wc (2.74 kPa).

Prior to use, check for damaged parts such as hoses, regulators, pilots, or burners.

Inspect the fuel supply connection for signs of leakage (including the hose for the LP models) before each use of the appliance.

All leak tests should be done with a soapy solution. NEVER USE AN OPEN FLAME TO CHECK FOR LEAKS.

Children and adults should be alerted to the hazards of high surface temperatures and should stay away from the appliance to avoid burns or clothing ignition. This appliance comes with a heat shield which is an important safety component preventing contact with the fire bowl when adjusting the propane valve.

Young children should be carefully supervised when they are in the area of the heater.

Clothing or other flammable materials should be not be hung from the heater, or placed on or near the heater.

Any guard or other protective device removed for servicing the heater, must be replaced prior to operating the heater.

Installation and repair should be done by a qualified service person. The heater should be inspected before use and at least annually by a qualified service person.

More frequent cleaning may be required as necessary. It is imperative that the control compartment, burners, and circulating air passageways of the heater be kept clean.

Keep the appliance area clear and free from combustible materials, gasoline, and other flammable vapors and liquids.

DO NOT OBSTRUCT the combustion process or air ventilation flow.

Keep the ventilation opening(s) of the cylinder enclosure free and clear from debris.

The appliance should be used in a well-ventilated space and not in a building, garage or any other enclosed area.

An appliance may be installed within a shelter if the shelter meets one of the following conditions:

The shelter has walls on all sides, but with no overhead cover.

The shelter is within a partial enclosure which includes side walls. These side walls may be parallel, as in a breezeway, or at right angles to each other.

Pre-Assembly

PLANNING ASSEMBLY

Carefully remove all pieces from the carton and make sure that you have all parts (refer to the hardware and package contents list). If you are missing parts, please contact 1-877-606-2818 for further assistance.

YOUR OWNER'S MANUAL

Keep and store this Owner's Manual for future reference. It contains important instructions and procedures for safety and maintenance.



NOTE: Please read and understand the entire manual before you assemble, operate, or install the fire pit.

TOOLS REQUIRED (NOT INCLUDED)

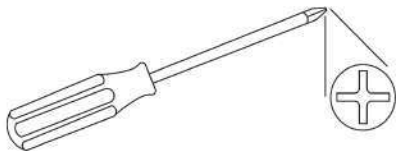

Phillips screwdriver

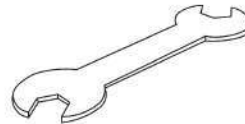

M6 Wrench

HARDWARE INCLUDED

Part	Description	Quantity
AA	M6×12 mm Bolt	23
BB	M6×16 mm Bolt	4
CC	M6×20 mm Hex Head Bolt	1
DD	M5×10 mm Bolt	4
EE	M5 Nut	4
FF	AAA Battery	1

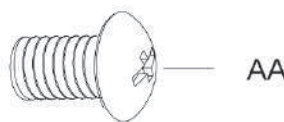

AA

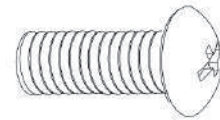

BB

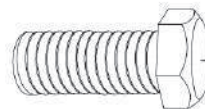

CC

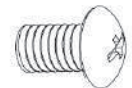

DD



EE



FF

Package Contents

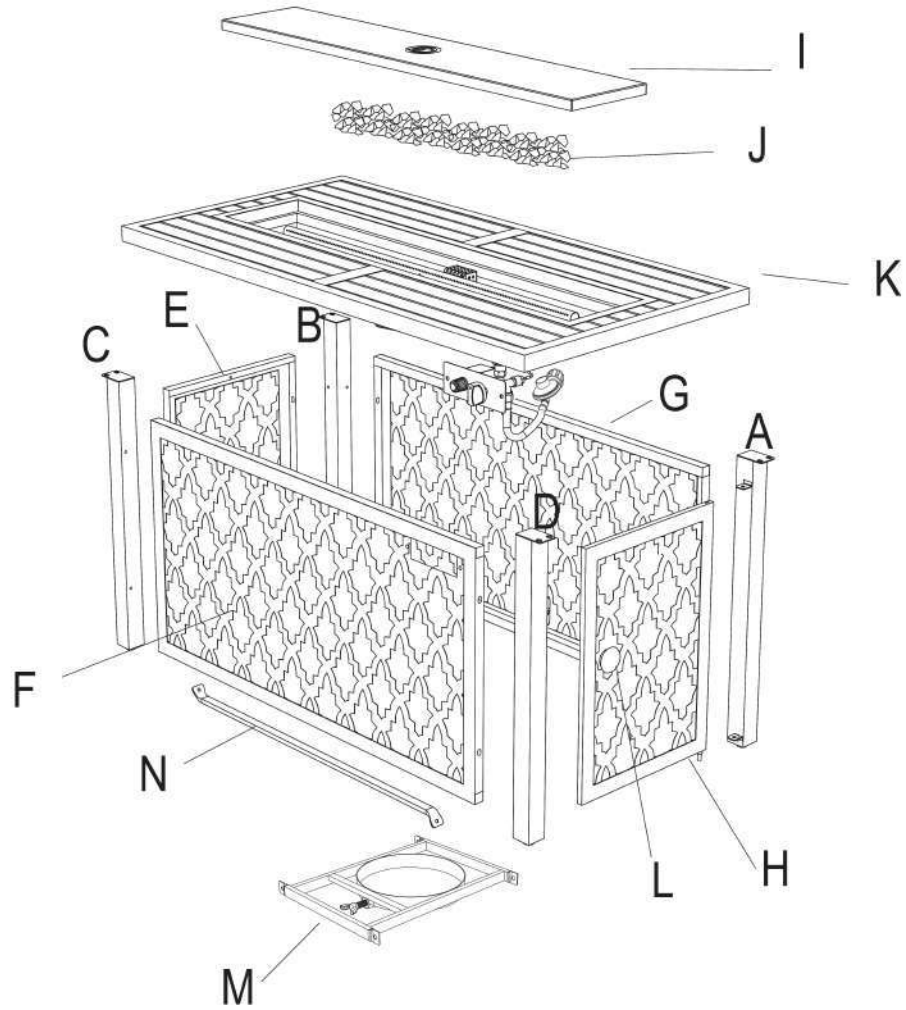

PART	DESCRIPTION	QUANTITY
A	Leg A	1
B	Leg B	1
C	Leg C	1
D	Leg D	1
E	Back Panel	1
F	Side Panel With Window	1
G	Side Panel	1
H	Door	1
I	Lid	1
J	Fire Glass	1
K	Table Top With Burner	1
L	Door Knob	1
M	Tank Support	1
N	Cross Bar	1

Assembly

Step 1:

Attach Door Knob (L) to Door Panel (I) using one (1) M6 x12mm Bolt(AA).

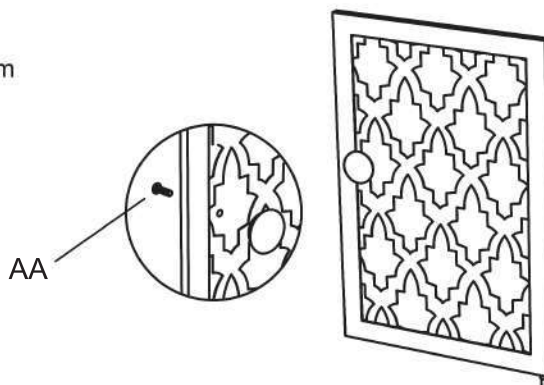

Step 2:

Attach the leg (ABCD) to the table top by using eight M6*12 Bolts.

Attach Back panel (E) to Leg (B) and (C) with four M6*12 Bolts (AA).

Phillips head screwdriver (not included). Please do not tighten any screws to the end at this step.

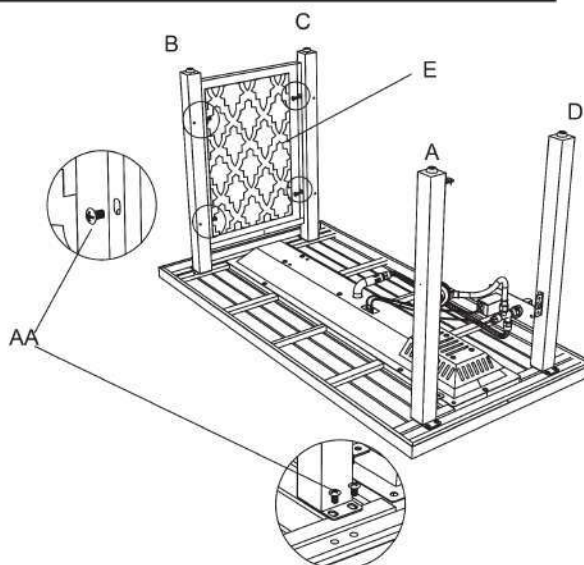

Step 3:

Attach side panel (G) to leg (A) and (B) by using four M6*12mm Bolts (AA).

Please use Phillips head screwdriver (not included). Please do not tighten any screws to the end at this step.

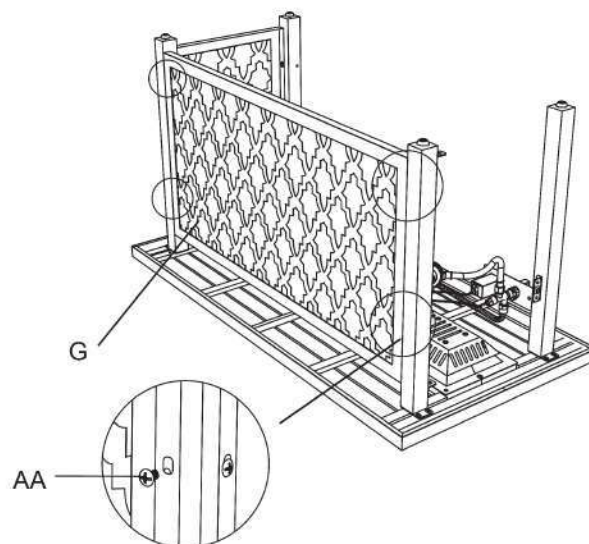

Assembly (continued)

Step 4:

Attached the Side Panel With Window (F) to Leg(C) and (D) by using four M6*12mm bolt (AA).

Do not tighten the bolts at this step.

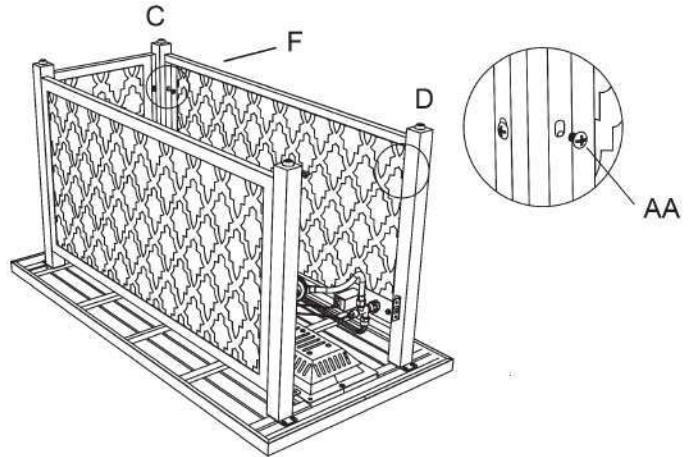

Step 5:

Pull out the control panel and attach it to side panel with window (F) with four M5*10 mm bolts(DD) and M5 Nut(EE). Please use Phillips head screwdriver (not included).

Please do not tighten any screws to the end at this step.

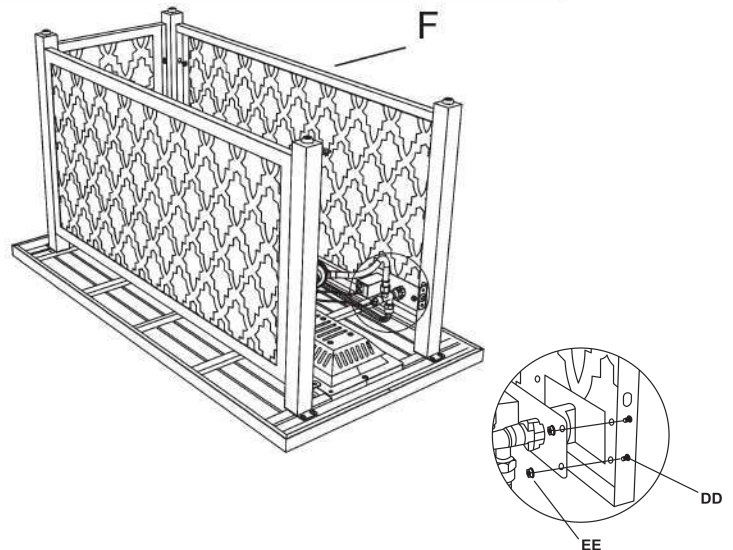

Step 6:

Position as shown. Attach propane tank support(M) to Side panel (G) and Side Panel With Window (F) by using four M6*16mm bolts (BB).

Locate the cross bar(N)to back panel and tank support by using M6x12mm bolt. Please use Phillips head screwdriver (not included). Please tighten all the screws for step 2-6.

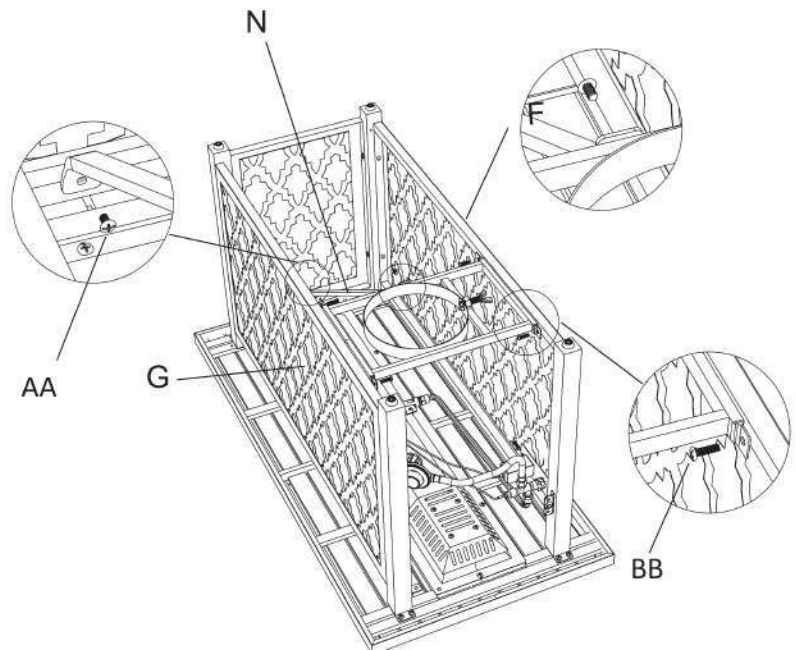

Assembley (continued)

Step 7:

Insert the door(H) to the leg(A),and attach it with one(1) M6x20mm Hex Head Bolts(CC).

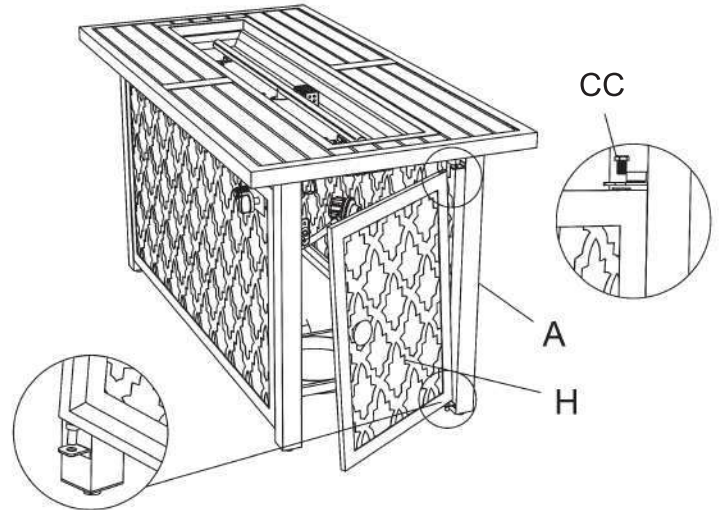

Step 8:

Place the propane tank (not included) onto the propane tank support (M). Secure the tank by tightening the screw of the propane tank support(M). Connect the hose and regulator to the propane tank.

NOTE: USE A STANDARD 20LB PROPANE TANK ONLY.

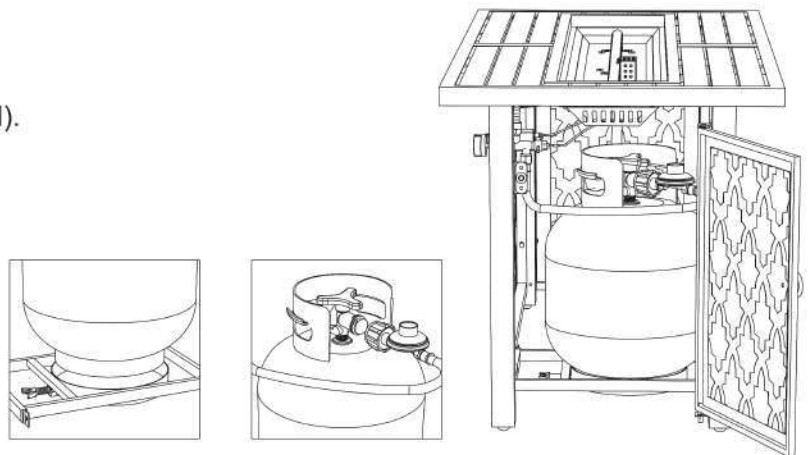

Step 9:

Open the igniter cover and place the AAA battery into it. Then tighten the igniter cover completely.

Place the fire glass into fire bowl,Ensure fire glass do not cover the ignition portion of the burner .

Finish and enjoy your fire pit table.

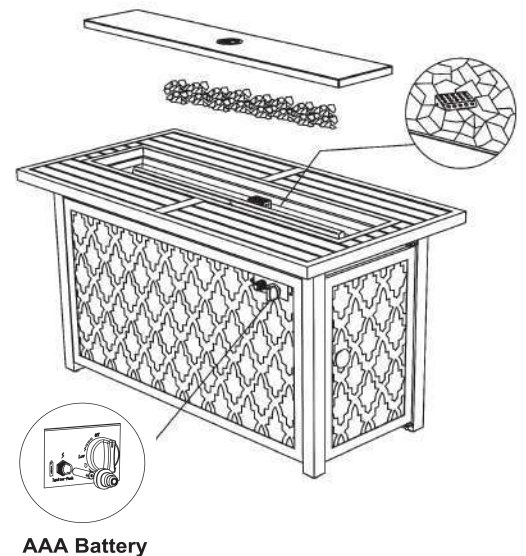

Operating



WARNING: Never use this appliance for other than the intended use. DO NOT use this appliance to prepare food.

Initial Lighting: When lit for the first time, the appliance emits a slight odor. This is a normal temporary condition caused by the “burn-in” of internal paints and lubricants used in the manufacturing process and does not occur again. Simply run the main burner on high for approximately one-half hour.



WARNING:

Children and adults should be alerted to the hazards of high surface temperatures and should stay away from the appliance to avoid burns or clothing ignition. The appliance comes with a heat shield which is an important safety component preventing contact with the fire bowl when adjusting the propane valve.

Children should be carefully supervised when they are in the area of the appliance.

Clothing or other flammable materials should not be hung from the appliance, or placed on or near the appliance. The area above the fire pit may be extremely hot. Direct contact with these surfaces should be avoided in order to prevent burns or clothing ignition.

Any guard or protective device removed for servicing the appliance must be replaced prior to operating the appliance. Installation and repair should be done by a qualified service person.

The appliance should be inspected before each use and at least annually by a qualified service person. More frequent cleaning may be required necessary. It is imperative that the control compartment, burners and circulating air passageways of the appliance be kept clean.



WARNING:

Never use the appliance while it is raining. Always turn the appliance off when raining.

Never use the appliance if the burner is damaged. Inspect the burner before each use. Ensure that no debris such as leaves; grass or other objects have entered or are on the appliance. If the burner is damaged it must be replaced prior to using this appliance with a replacement burner specified by your dealer.

Inspect the hose assembly before each use. If there is evidence of excessive abrasion or wear, or if the hose is damaged it must be replaced prior to using the appliance with a replacement hose assembly specified by your dealer.



WARNING: Any modification to the appliance may compromise the safety of this appliance.

Special concern is as follows:

Do not bypass the thermocouple safety.

Do not operate the appliance if any parts have been under water. Immediately call a qualified service technician to inspect the appliance and replace any part of the control system, and any gas control, which has been under water.

Operating (continued)

LEAK TESTING OPERATION



WARNING: A leak test must be performed annually or if a part of the gas system is replaced.



WARNING: Never use an open flame to check for gas leaks. Be certain no sparks or open flames are in the area while you check for leaks. Sparks or open flames will result in a fire or explosion, damage to property, serious bodily injury, or death.

LEAK TESTING:

- 1, Make 2-3 oz. of leak detection solution by mixing one part liquid dishwashing soap with three parts water.
- 2, Make sure all fire pit and light valves are OFF
- 3, Apply several drops of solution where hose attaches to regulator.
- 4, Apply several drops of solution where regulator connects to cylinder.
- 5, Turn cylinder valve ON.

If bubbles appear at any connection, there is a leak.

- 1, Turn cylinder valve OFF.
- 2, If leak is at hose/regulator connection: tighten connection and perform another leak test. If bubbles continue appearing, pls contact 855-600-9294 for assistance.
- 3, If leak is at regulator/cylinder valve connection: disconnect, reconnect, and perform another leak test. If you continue to see bubbles after several attempts, cylinder valve is defective, and contact 855-600-9294 for assistance.

If NO bubbles appear at any connection, the connections are secure.

NOTE: Whenever gas connections are loosened or removed, you must perform a complete leak test .

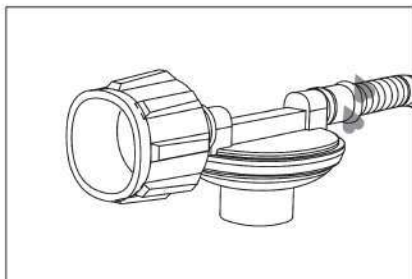

Hose/Regulator
Connection

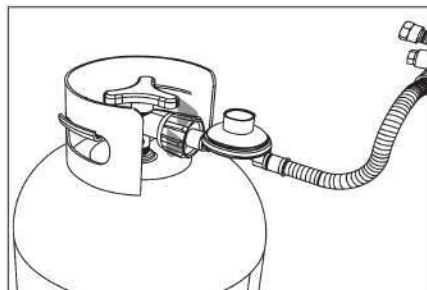

Regulator/Cylinder
Connection

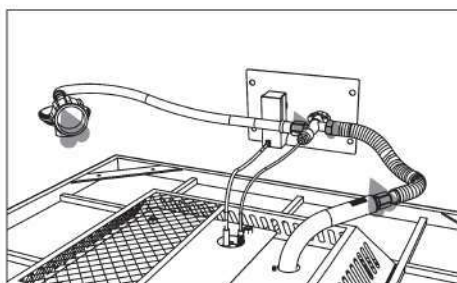

Operating(continued)

LIGHTING



CAUTION: Keep the outdoor gas appliance area clear and free from combustible materials, gasoline and other flammable vapors and liquids.

CAUTION: Do NOT obstruct the flow of combustion and ventilation air.

CAUTION: Check and clean burner/venturi tubes for insects and insect nests. A clogged tube can lead to a fire.

Lighting:

1. Make sure the control knob is in the "OFF" position (Figure A).

2. Fully open LP cylinder valve.

Note: For initial start or after any cylinder change, hold Control Knob IN for 2 minutes to purge air from gas lines before proceeding.

3. Push in gas control knob, turn counterclockwise to "LOW" (Figure B), and press the RED Ignitor button to light the fire table. If needed, keep the control knob depressed and continue pressing the RED Ignitor button until the fire table lights (you should hear a clicking sound).

4. After the fire table lights, release control knob. To increase the flame, turn the control knob counterclockwise to "HIGH" (Figure C). To decrease the flame, turn the control knob clockwise to "LOW".

Note: If burner fails to remain lit, all valves should be closed and a waiting period of at least 5 minutes should pass before attempting to light.



WARNING: If the burner does not light within 10 seconds, turn the valve off and wait 5 minutes for gas to dissipate before repeating the procedure



WARNING: Surface of the fire pit can remain extremely hot for a period after use. Allow 45 minutes to cool to dissipate before repeating the procedure.

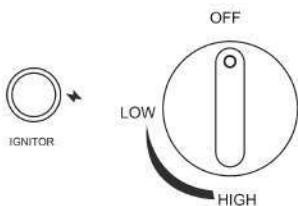

Figure A

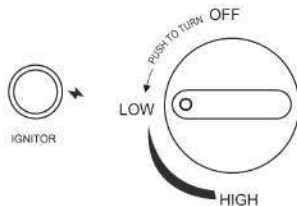

Figure B

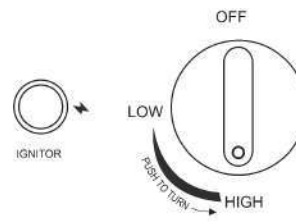

Figure C

Shut Down

1. To extinguish burner depress control knob and continue to turn it clockwise to "OFF"

2. Turn cylinder valve clockwise to "OFF" and disconnect regulator when fire pit is not in use.

Maintenance

Storage between uses:

- Turn the control knob to "OFF" position.
- Disconnect LP source.
- Store heater upright in an area sheltered from direct contact with inclement weather (such as rain, sleet, hail, snow, dust and debris).
- If desired, cover heater to protect exterior surfaces and to help prevent build up in air passages.



NOTE: Wait until heater is cool before covering.

Storage during periods of extended inactivity or when transporting:

- Turn the control knob to "OFF" position.
- Disconnect LP source and move to a secure, well ventilated location outdoors. DO NOT store in a location that will exceed 125 °F.
- Store heater upright in an area sheltered from direct contact with inclement weather (such as rain, sleet, hail, snow, dust and debris).
- If desired, cover heater to protect exterior surfaces and to help prevent build up in air passages.



NOTE: Wait until heater is cool before covering.

Care and Cleaning

To enjoy years of outstanding performance from your heater, make sure you perform the following maintenance activities on a regular basis:

- Whenever conduct hose/regulator inspection, pull out the door using handle on the door panel to gain access.
- Keep exterior surface clean.
- Use warm soapy water for cleaning. Never use flammable or corrosive cleaning agents.
- While washing your unit, be sure to keep the area around the burner dry at all times. If the gas control is exposed to water, do NOT try to use it. It must be replaced.
- Keep the appliance area free and clean from combustible materials, gasoline or other flammable vapors and liquids.
- At least once a year, the unit should be inspected for the presence of spiders, spider webs or other insects.
- Air flow must be unobstructed. Keep controls, burner, and circulating air passageways clean. Signs of possible blockage include:
 - Gas odor with extreme yellow tipping of flame.
 - Heater does NOT reach the desired temperature.
 - Heat glow is excessively uneven.
 - Heat makes popping noises.
- Spider and insects can nest in burner or orifices. This dangerous condition can damage heater and render it unsafe for use. Clean burner holes by using a heavy-duty pipe cleaner. Compressed air may help clear away smaller particles.
- Carbon deposits may create a fire hazard. Clean reflector, thermocouple, and emitter screen with a dry cloth if any carbon deposits develop.
- The burner is made from stainless steel, but extreme heat and a corrosive environment can cause surface corrosion to occur. This can be removed with a brass wire brush. Inspect the burner at least annually for cracks, insect nests, excessive corrosion or any other damage. If the burner is damaged, it must be replaced with a burner specified by the manufacturer before the appliance is put into operation.

Troubleshooting

PROBLEM	PROBLEM CAUSE	SOLUTION
The flame and heat are low when the valve is turned to high.	The propane lighting procedure was not followed correctly.	Ensure lighting procedure is followed carefully. The valve must be in the off position when the tank valve is turned on. Turn the tank on slowly to allow pressure to equalize. See Lighting Instructions in the Operating section.
Burners burn with yellow flame, accompanied by the smell of gas.	There is possibly a spider web or other debris.	Thoroughly clean the burner venturi. See the Maintenance section.
The burner will not light with the igniter, but will light with a match.	The battery is either dead or installed incorrectly. There is a loose electrode wire or switch terminal wires.	Check the installation or replace with a new battery. Check that the electrode wire is firmly pushed onto the terminal on the back of the igniter. Check that the lead wires from the module to the ignition switch (if equipped) are firmly pushed onto their respective terminals.
The burner will not stay lit when control knob is released.	The knob is not being held in long enough. It is too windy outside. Lava rock or debris are in the ignition area of the burner preventing the thermocouple from being fully engulfed in flame. Either the thermocouple or thermocouple connection is dirty. Either the thermocouple or valve is faulty.	The thermocouple must have time to heat up. Hold the knob in for 30 seconds after the burner lights, then release. The unit will shut down if winds are greater than 10 mph (16 km/h). Either locate the fire pit to a different area or use when it is less windy. Ensure there is no lava rock or other debris in the ignition area, and that the small hole below the thermocouple is unobstructed. Clean the thermocouple and clean the connection between the valve and thermocouple. Ensure the connection is properly tightened. Replace thermocouple and/or valve.
The regulator is humming.	This is a normal occurrence on hot days.	This is not a defect. It is caused by internal vibrations in the regulator and does not affect the performance or safety of the gas heater. Humming regulator will not be replaced.
The valve is set to high but there is low heat output. There is also a rumbling noise and a fluttering blue flame at the burner surface.	There is not enough gas. The supply hose is pinched. The burner orifice is either dirty or clogged. There are spider webs or other matter in venturi tube. The propane regulator is in a "low flow" state.	Check the gas level in the propane cylinder. Reposition the supply hose as necessary. Clean the burner orifice. Clean out the venturi tube. Ensure the lighting procedure is followed carefully. All valves must be in the off position when the tank valve is turned on. Turn tank on slowly to allow pressure to equalize. See the Lighting Instructions in the Operating section.



Questions, problems, missing parts? Before returning to the store
please contact our Customer Service

• service@alphamarts.com •

1-877-606-2818