

OL-R190B

Please read this user manual before operating and save for future reference.

You've been covered with a 1-year free warranty offered by APTOOK which is automatically valid from the date of purchase. If you have any question, please email APTOOK at support@aptook.com

CONTENTS

INSTRUCTIONS.....	1
BEFORE YOU BEGIN	2
IMPORTANT SAFETY TIPS.....	3
SPECIFICATIONS.....	4
PRODUCT OVERVIEW.....	5
OPERATION.....	6
AUTO DRAINAGE & MAINTENANCE...8	
PARTS LIST.....	9
TROUBLE SHOOTING GUIDE.....	10
SAFETY PRECAUTIONS.....	11
CUSTOMER SERVICE.....	12

INSTRUCTIONS

Thank you for choosing the dehumidifier by APTOOK!

We hope it will bring great convenience to your work and life. We recommend that you save the user manual properly for future reference. Before using this product, please read the user manual carefully to ensure that this product functions at its best.

The APTOOK's dehumidifier adopt an upgraded design, compact structure, easy to operate, and other characteristics, widely used in scientific research, sanitation, commodity storage, underground engineering, and dehumidification in high humidity places such as kitchens, bathrooms, archives, warehouses, etc. Can be effectively avoided telecommunications equipment, materials, etc, are damaged due to dampness or rust.

Dehumidifier reduces humidity in enclosed environments by removing water vapor from the air. The APTOOK R190B is ideal for crawlspace drying, humidity control and other applications.

Transportation and Custody

During transportation, this product should be handled preciously to prevent violent vibration. Generally, the packaged product should not be stored in the open air for a long time. It should be placed in a well-ventilated, non-corrosive gas warehouse. It should not be placed upside down. Set unit upright, Always store, transport, and use the unit in a horizontal position. If the unit is ever placed in a vertical position, return it to the horizontal position and let it stand for at least **24 hours** before turning it on. Rainproof measures should be adopted when stored temporarily.

For best results, operate your dehumidifiers in an enclosed area.

Place your dehumidifier away from obstructions, and keep it away from anything that could block airflow into and out of the unit.

We also kindly ask you to take a few minutes to register your product at www.aptook.com for more efficient support.

We are always just an email away

To access customer support, please email to support@aptook.com with your purchase order ID to help us address the problem faster and serve you better.

BEFORE YOU BEGIN

The information contained herein is subject to change without notice.

The user manual contains instructions and notes on the operation and use of this unit.

APTOOK recommends that you use genuine accessories from APTOOK.

APTOOK shall not be responsible for any damage or expense that might result from the use of parts other than genuine parts from the APTOOK.

Do not use unofficial components or accessories that may result in a risk of fire, electric shock, or injury to persons. If you need to replace any components or accessories, please visit official APTOOK channels to check relevant information.

For your safety and benefit, please read carefully before using and keep it handy for future reference.

IMPORTANT SAFETY TIPS

Before using the product, for safe and correct operation and maintenance, please read and understand the following safety tips

1. Unplug the power supply before cleaning or storing the machine.
2. Never immerse the machine into water or other liquids.
3. Do not put the machine close to heat-generating devices, including flammable or dangerous materials.
4. Do not put fingers or other items into air inlet or air outlet.
5. Do not sit, stand or put heavy objects on the machine.
6. Never operate the machine when the power cord or plug is damaged. This may cause damage or injury. Please contact your local distributor for service issues.
7. This appliance should only be used by adults who have read the manual and understand the operating procedure of the unit.
8. The appliance is not to be used by persons (including children) with reduced physical, sensory or mental capabilities, or lack of experience and knowledge, unless they have been given supervision or instruction by an adult.
9. Install the machine on flat surface to minimize vibration and or noise.
10. Never insert any other objects into the machine body.
11. If the supply cord is damaged, it must be replaced by the distributor or qualified electrician.



Never repair or remove plug and or power cord. Any repairs should be completed by qualified electrician or distributor.

SPECIFICATIONS

DEHUMIDIFIER	
Model No.: OL-R190B	
Voltage & Hertz	AC115V / 60Hz
Power Consumption& Current	735W/6.8A @80°F, 60% RH 900W/8.4A @86°F, 80% RH
Refrigerant Charge	R410a/19.8oz
Dehumidify Capacity	90Pints/Day @80°F, 60% RH 190Pints/Day @95°F, 80% RH
Maximum Design Pressure	High Side: 522psig (3.6MPa) Low Side: 240psig (1.65MPa)
BCSC	15A
Compressor Input	RLA: 7.3A LRA:36.4A
Fan Motor Power	0.107HP

FEATURES

- Hot Gas Valve system for fast defrost
- Easy to assemble and disassemble the housing for repair
- With fast connector of hose , convenient for assembly and disassemble
- Foldable handle ,easy to operate
- Quick pump access in front for easy servicing
- Tough semi-pneumatic wheel

PRODUCT OVERVIEW

Parts Diagram

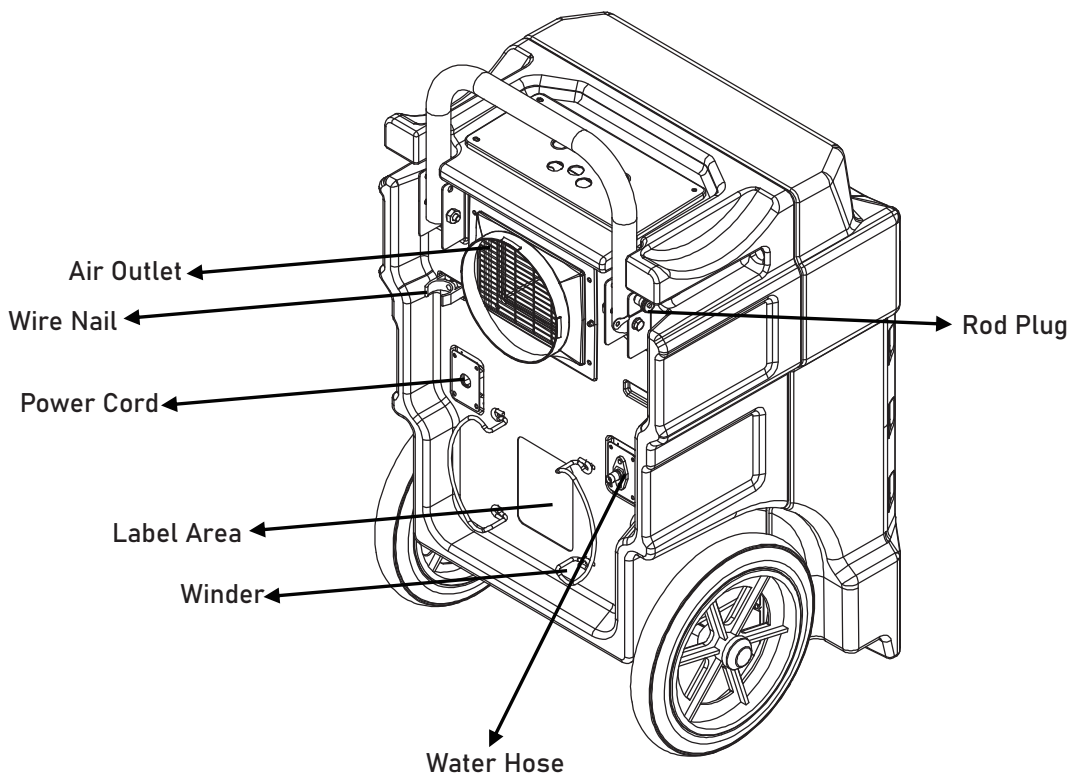
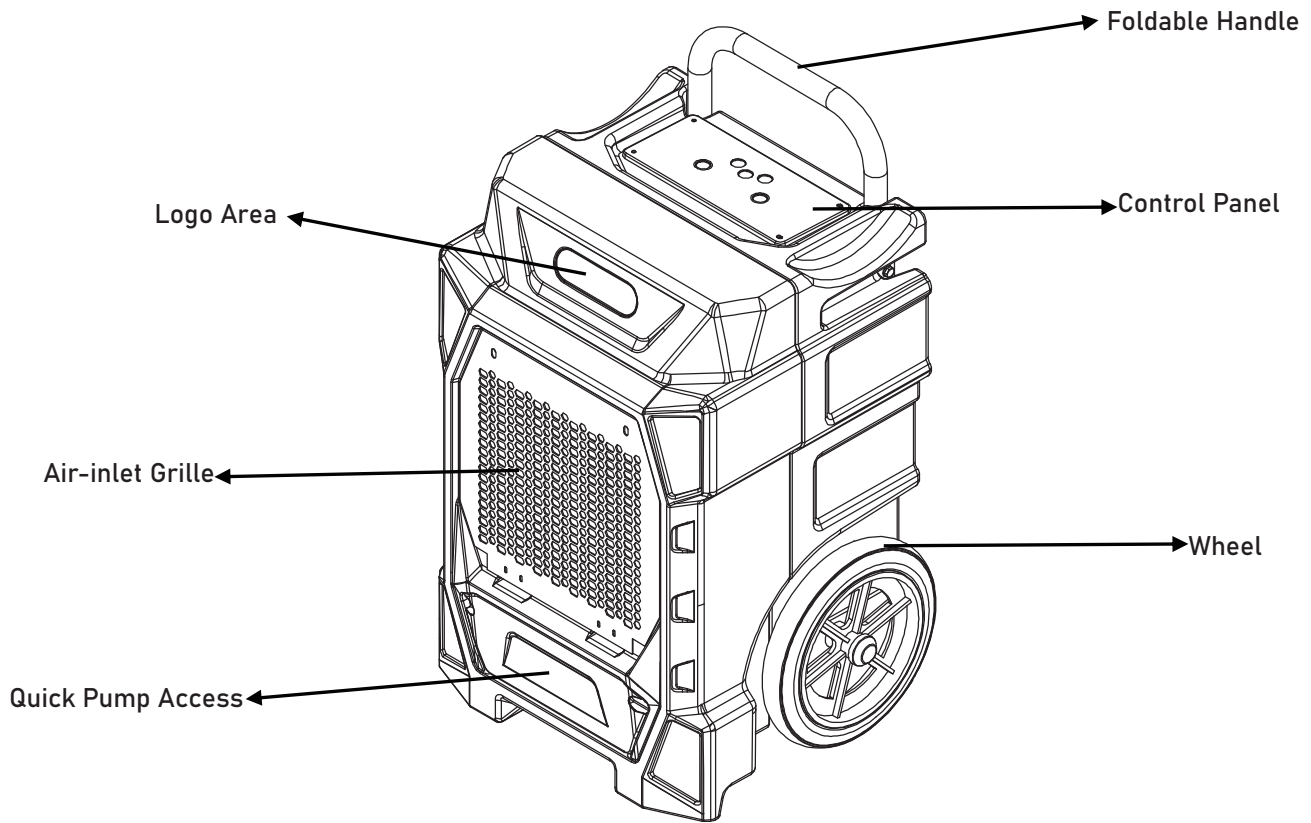

OPERATION

Control Panel Guide

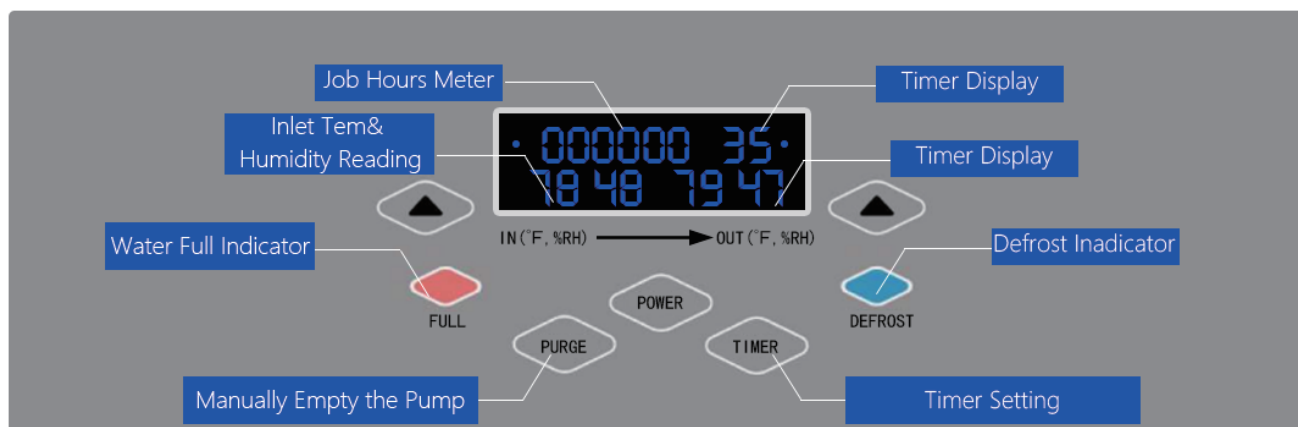

Power Button: When the machine is in the standby mode, the display screen will be displayed in low light LED. To start the dehumidifier, press the power button.

Concurrently, the display screen will light up and the unit will run in Auto mode, the default humidity setting data is 10% RH, and the machine will start if the humidity condition meets the requirement of compressor operation.

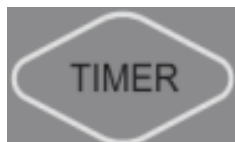

Timing Button: Press the timing button, the display screen will show the current timing data, and then press Add button  to increase the timing data or press Minus button  to decrease the timing data.

Press one time to increase or decrease one hour. The timing indicator will light up after setting. When the machine is in the standby mode, press the timing button to set the start-up time; when the machine is running, press it to set the shutdown time. The timing setting range is from 0 to 24 hours. If you set the timing data as "00", it will cancel timing function, the timing indicator will turn off.



Add Button: Press the Add button to increase humidity data or increase timing data. When setting the humidity data, press the button for one time to increase 5%RH, you can set the humidity range from 10%-90% RH, and 5% RH for one step,

it will cycle as below: 10%-15%-20%-25%-30%-35%-40%-45%-50%-55%-60%-65%-70%-75%-80%-85%-90%-10% ...When setting the timing data, press the button for one time to increase 1 hour, you can set the timing range from 1-24 hours, and 1 hour for one step. it will cycle as below: 01-02-03-04-05...-23-24-00-01-02...



Minus Button: Press the Minus button to decrease humidity data or decrease timing data . When setting the humidity data , press the button for one time to decrease 5% RH , you can set the humidity range from 90%-10% RH, and 5% RH for one step , it will cycle as below : 90%-85%-80%-75%-70%-65%-60%-55%-50%-45%-40%-35%-30%-25%-20%-15%-10%-90% ...When setting the timing data , press the button for one time to decrease 1 hour , it will cycle as below:24-23-22-21-20...-02-01-00-24-23...



Purge Button (Manual Drainage): Press and hold the purge button for 3 seconds, the machine will drain the water automatically by the built-in pump. After 30 seconds, the pump stops draining, then the indicator will turn off.



Defrosting Indicator: When the machine is defrosting, this indicator turns on. After defrosting, it turns off.



Water Full Indicator: When the water pump is full of water, the indicator light turns on to remind the user to drain.

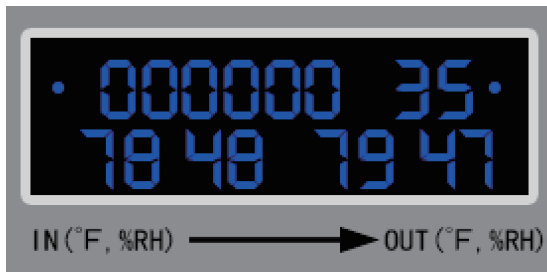

Display Screen: The default temperature display is Fahrenheit temperature. When the machine is in standby mode, press the power button for 5 seconds to switch to Celsius temperature. When the machine is running, it shows the temperature and humidity of the inlet air and outlet air.

It displays the running time when it is in running mode; and displays the setting timing and setting humidity data when users set .

Memory Function: If there is a power outage or the unit shuts off ,it will auto restart to its original settings except timing ,once power is restored .

Note :

When humidity of air inlet \geq setting humidity data +3%RH ,and the compressor is out of 3 minutes delay start protection , the fan will start immediately and the compressor will start in 3 seconds later.

When humidity of air inlet \leq setting humidity data -3%RH , the compressor will stop working immediately ,and the fan will stop working in 1 minute later.

AUTO DRAINAGE & MAINTENANCE



Please disconnect the power supply before cleaning or conducting maintenance.

Cleaning: Clean the unit body with a soft damp cloth. Do not submerge or place water on the unit or control panel. Water may damage the electronic components of the unit.

Do not use chemical solvent such as benzene, alcohol, gasoline or other heavy-duty cleaner.

The surface may become damaged or deformed.

Cleaning the Air Filter:

Step 1: Pull out the air filter gently.

Step 2: Use a vacuum cleaner to remove the dirt on the surface of the air filter.

If the air filter is exceptionally dirty, immerse it gently into warm water (about 40°C) with a neutral detergent, rinse and dry it thoroughly.

Step 3: Insert the filter back into the unit.

Dehumidifier Storage:

1. Push the purge button to empty the water before transportation or storage.
2. Transport and store the machine upright.
3. Stack machines in warehouse to save space.



Cautions:

If unit malfunctions turn off the unit and unplug it immediately. Please contact your distributor for service issues.



Do not dispose of electrical appliances in local landfills, or municipal waste locations. Many parts are recyclable. Contact your local government for information regarding the collection systems available in your area.

PARTS LIST

Picture	Name	Quantity
 A line drawing of a portable dehumidifier with a carrying handle on top and a wheel on the side.	Dehumidifier	1PCS
 A line drawing of a coiled drain hose with a connector at one end.	Drain Hose	1PCS
 A line drawing of an open book representing a user manual.	User Manual	1PCS

TROUBLE SHOOTING GUIDE

Error prompt and code running status

1. "E1" code: This code appears when the copper head sensor is damaged. The machine will keep running, but every 30 minutes, the compressor will stop for about 10 minutes, then continue to run. After that, the machine will repeat the cycle like this.
2. "E2" code: This code appears when the temperature and humidity sensor is damaged. The machine will keep running, but every 30 minutes, the compressor will stop for about 10 minutes, then continue to run. After that, the machine will repeat the cycle like this.
3. "E4" code: This code appears when water tank of water pump is full or failure of water pump, the machine will stop running.

Trouble	Possible Cause	Solution
Error Code: E1	Copper head sensor failure	Request Replacement Kits
Error Code: E2	Air inlet temperature and humidity sensor failure	Request Replacement Kits
Error Code: E3	Air outlet temperature and humidity sensor failure	Request Replacement Kits
Error Code: E4	Water pump failure or Water tank of water pump is full	Replace it or check the water pump
Error Code: E5	4-way valve failure	Request Replacement Kits

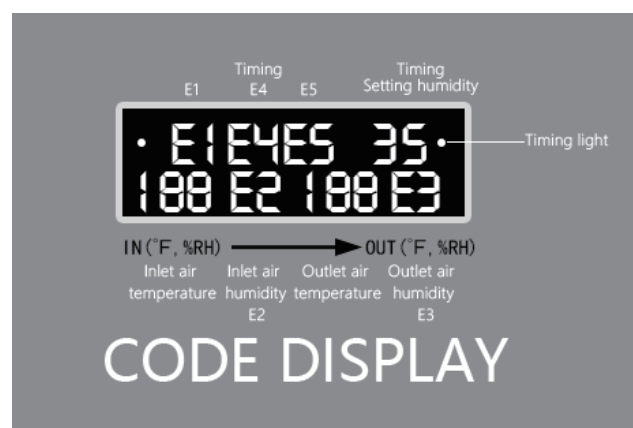

SAFETY PRECAUTIONS



1. When using, do not place the dehumidifier on soft, uneven ground to avoid vibration or movement.



2. Do not use thin rods or hard objects to insert into the fuselage to avoid malfunction or danger.



3. When using, please keep the dehumidifier away from heat sources such as heaters and electric kettles to save electricity.



4. When using, please close the doors and windows to achieve the best dehumidification effect.

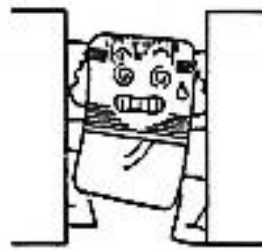

5. Do not place items before and after the dehumidifier. If the ventilation is blocked, the dehumidification effect will be affected.



6. In case of power failure or long-term non-use, please unplug the power cord.



7. When cleaning the dehumidifier, gently wipe it with a damp cloth, do not directly spray water to clean it.

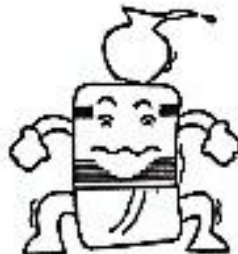

8. Do not place any objects on the dehumidifier.



10. Please clean the filter every two weeks (do not use hot water above 104°F/40°C, alcohol, gasoline, or toluene).



9. During continuous drainage, the drainage pipe must be placed horizontally or downwards, and must not be uneven or entangled.

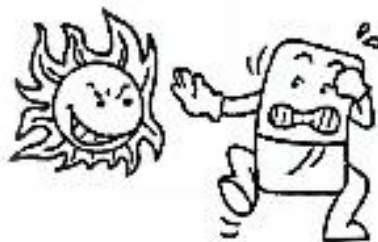

11. After the filter is cleaned, please do not place it in direct sunlight to dry it to avoid deformation.



12. Before moving or carrying the dehumidifier, please pour out the accumulated water in the water tank.

CUSTOMER SERVICE

APTOOK offers a limited 1-year free warranty on this OL-R190B dehumidifier, with original proof of purchase (typically you may be only requested to offer the order number or other information to prove a genuine purchase, instead of an invoice) and where a defect has arisen, wholly or substantially, as a result of faulty manufacture, parts or workmanship during the warranty period. During the warranty period, for the damaged part, we will provide a replacement part if it can be restored to normal use by replacing parts.

The warranty does not apply where damage is caused by other factors, including without limitation:

- Normal wear and tear;
- Abuse, mishandling, accident, or failure to follow operating instructions;
- Exposure to liquid or infiltration of foreign particles;
- Servicing or modifications of the product other than by APTOOK.

We will try our best to inspect the dehumidifier through photos or videos to troubleshoot and ensure that we can better solve the problem for you.

These are our general terms for warranty service, but we always urge our customers to reach out to us with any issue, regardless of warranty terms.

If you have an issue with a Lienuis product, please contact us at support@aptook.com, and we will do our best to resolve it for you.

Email

support@aptook.com



APTOOK

Commercial Dehumidifier

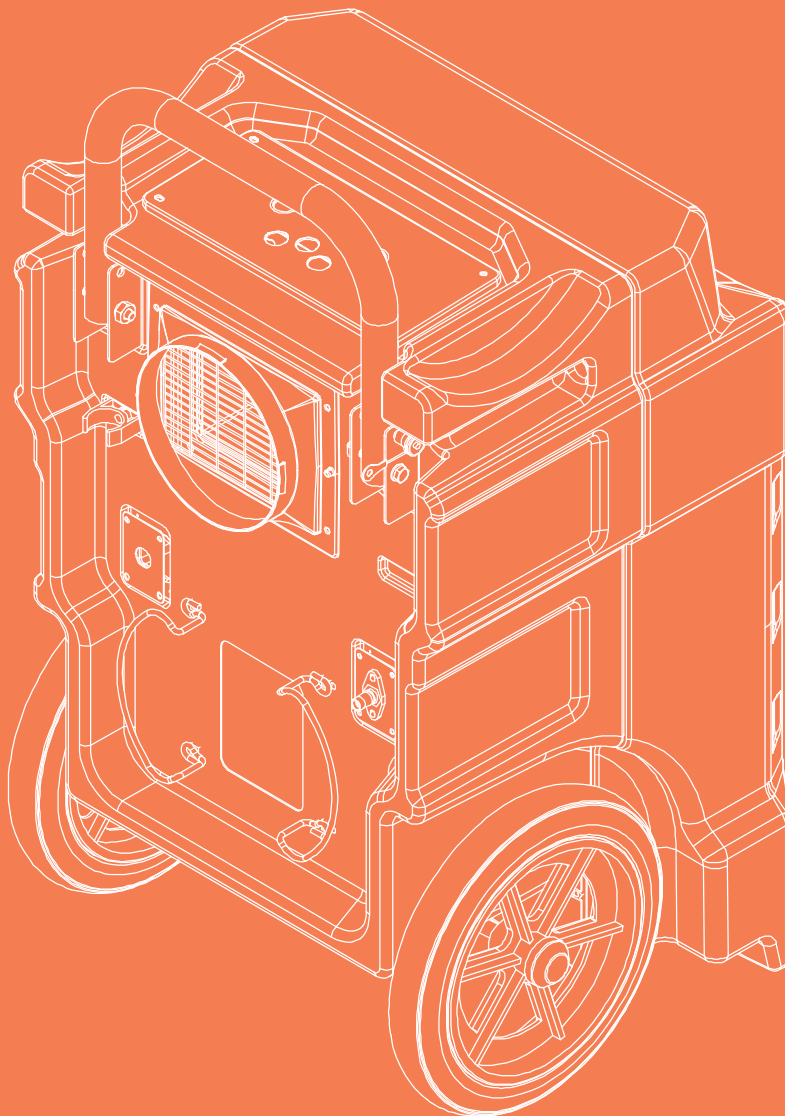

 www.aptook.com

 support@aptook.com