

SARGENT 7306 ES Crimp Adjustment

Top of Cam

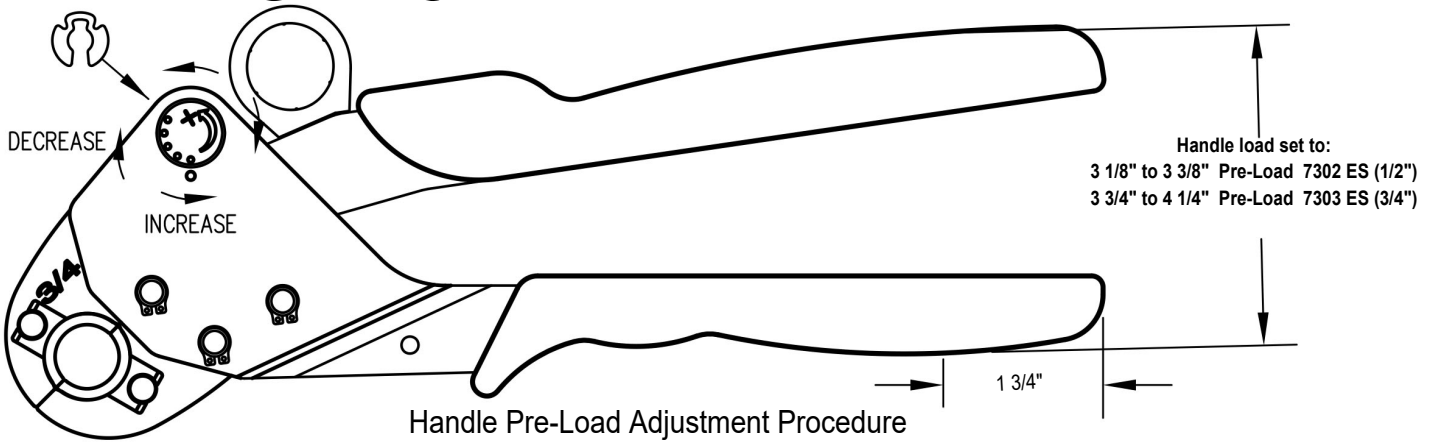

- 1) Handle pre-load adjustment is performed after it has been determined that the crimped ring/fitting connection no longer meets the industry standard by measuring with a caliper or the supplied gage. In either case do not measure across the flashed portion of the ring. See Fig 1.
- 2) Prior to adjusting the tool, measure the handle opening with jaws butting for later reference.
- 3) The tool should measure between 3 1/8"-3 3/8" for 1/2" and 3 3/4"-4 1/4" for 3/4" as shown above.
- 4) To adjust the tool, remove the retaining ring from the adjustment cam on the back side of the tool.
- 5) Push up the notched eccentric pin from below and rotate to the next available notch as shown above. Opening the handles slightly to remove spring tension will make turning and adjusting the eccentric easier. Rotate counter-clockwise to increase pre-load and clockwise to decrease pre-load as shown above if originally to the left side of the * . If originally to the right side of the* rotate in the opposite direction as shown. Do not pre-load any more than necessary to meet crimp gaging as crimping effort and tool wear will increase as well.
- 6) Push the eccentric lock down flush to engage toothed cutout and replace the retaining ring.
- 7) Check the handle load and subsequent crimps to ensure crimps are within specifications.
- 8) Readjust as required

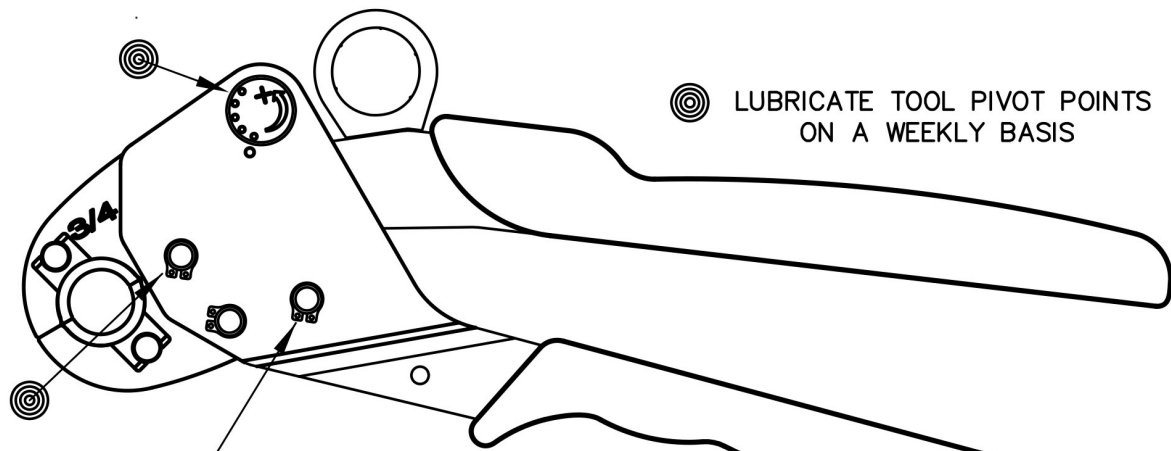

GAGE ALL CRIMPS!!

CRIMP RING GAGING (1/2")
 AFTER CRIMPING ON PIPE/FITTING ASSEMBLY

1/2" MAXIMUM, in (mm)	1/2" MINIMUM, in (mm)
.715 (18.16)	.700 (17.78)
	3/4" MINIMUM, in (mm)
	.945 (24.00)

FIG 1

AVOID THIS AREA WHEN GAGING CRIMPED FITTING

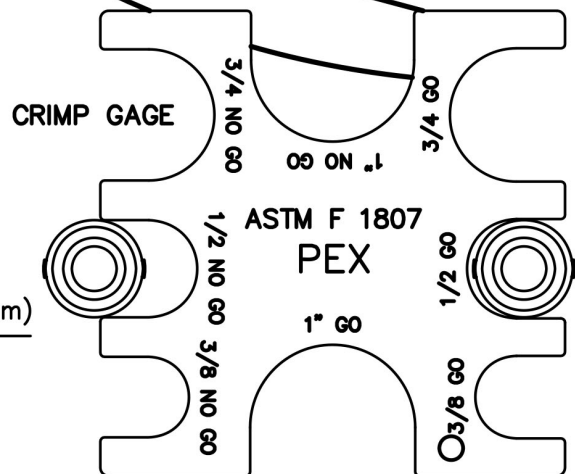

7306 ESK CRIMPING PROCEDURE

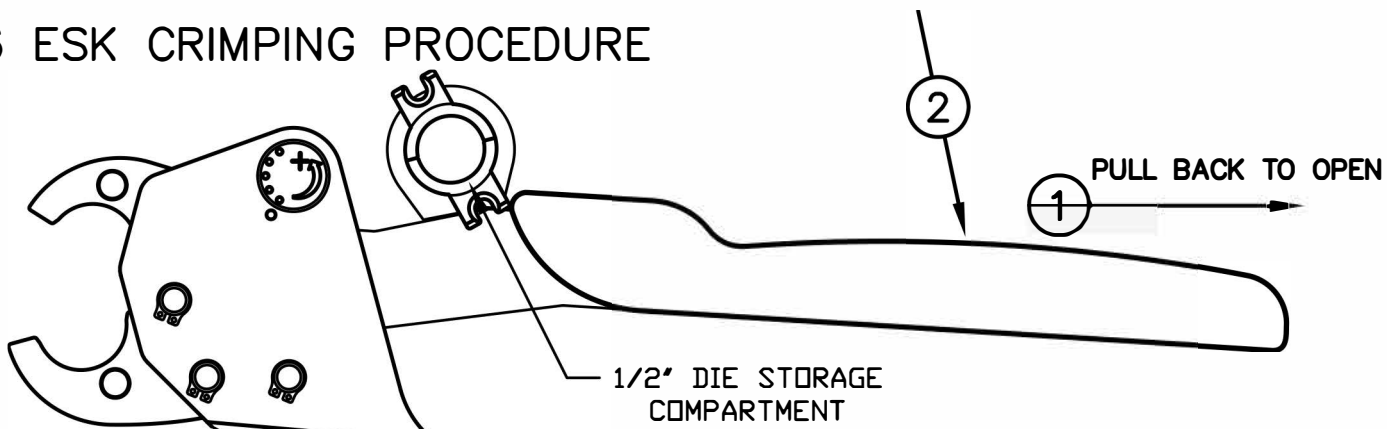

3) CENTER CRIMP RING ON BARBED FITTING

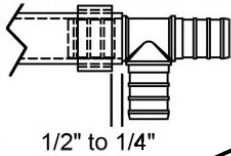

1/2" to 1/4"

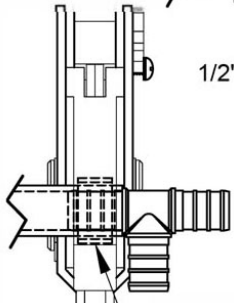

4

CRIMP RING
(CENTER AS SHOWN)

RELEASE TO CLOSE

5

CRIMPING PROCEDURE

- 1) Pull back on the upper moveable handle to open the tools jaws.
- 2) Grasp the tools handles lightly to maintain the tools open position.
- 3) Center crimp ring on barbed pex fitting as shown.
- 4) Position the jaws so that the crimp ring is centered within the tools jaws.
- 5) Loosen your grip to allow the spring pressure to close the jaws around the ring to be crimped. Before squeezing the handles make sure the ring is centered.
- 6) Squeeze the handles closed until the ends butt as shown below. CRIMP EACH RING ONCE ONLY!
- 7) Pull back on the upper handle to remove from the crimped ring, pipe and fitting.
- 8) Check the crimp with the gage provided. Measure the crimped fitting perpendicular to the seams of the crimp as shown. A properly crimped ring should pass the GO side of the gage and not pass the NO GO gage. If the ring does not pass the GO gage the tool is probably worn and needs to be adjusted as instructed in the Handle Pre-Load Adjustment Procedure.

