

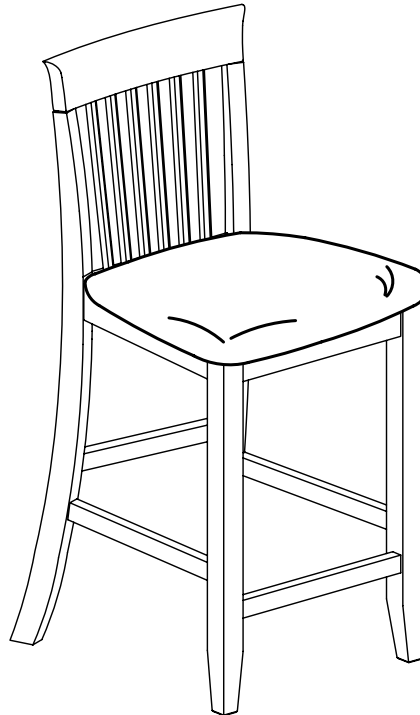

LINON HOME DÉCOR PRODUCTS, INC.

ASSEMBLY INSTRUCTIONS TORINO COLLECTION CRAFTSMAN COUNTER STOOL 01857DKCHY-01-KD-U



WE ARE HERE TO HELP !

WE DO OUR BEST TO INSURE THAT YOUR FURNITURE ARRIVES IN EXCELLENT CONDITION. IN THE EVENT THAT A PART IS DAMAGED OR MISSING, LINON HOME DECOR WILL BE HAPPY TO PROVIDE YOU WITH REPLACEMENT PARTS, AT NO CHARGE WITHIN 30 DAYS OF PURCHASE, PROVIDING THE PARTS ARE AVAILABLE IN OUR WAREHOUSE AND THE ITEM PURCHASED ARE PART OF OUR CURRENT INVENTORY. IN ORDER TO RECEIVE SPARE PARTS, AT NO CHARGE, YOU MUST PROVIDE PROOF OF PURCHASE WITHIN 30 DAYS.

IF YOU NEED ASSISTANCE WITH ASSEMBLY OR REPLACEMENT PARTS, PLEASE CALL LINON CUSTOMER SERVICE, PRIOR TO RETURNING THE ITEM TO THE STORE.

OUR OFFICE IS OPEN MONDAY-FRIDAY 9AM-5PM, EASTERN STANDARD TIME.
OUR TOLL FREE CUSTOMER SERVICE NUMBER IS: 1-800-262-1852.
OR VISIT OUR WEB SITE WWW.LINON.COM TO ORDER SPARE PARTS AND FOR CARE INSTRUCTIONS ON YOUR NEWLY PURCHASED FURNITURE.

IMPORTANT:

PLEASE READ ALL INSTRUCTIONS IN THIS BOOKLET BEFORE STARTING ASSEMBLY.
MADE IN VIETNAM

FOR LINON HOME DÉCOR PRODUCTS INC BY V18









LINON HOME DÉCOR PRODUCTS, INC.

HARDWARE PACKAGE COUNT

OPEN HARDWARE PACKAGE ON A FLAT SURFACE COVERED WITH NEWSPAPER. COUNT EACH PIECE OF HARDWARE TO MATCH THE QUANTITY NUMBER IN THE HARDWARE LIST COLUMN. CALL CUSTOMER SERVICE IF ANY OF THE PARTS ARE MISSING. FOLLOW THE LETTER IDENTIFICATION WHEN READING THE ASSEMBLY DRAWING "A" THROUGH "G"

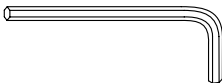
HARDWARE IDENTIFICATION

| CODE | HARDWARE | DESCRIPTION | QTY |
|------|---|---------------|-----|
| A |  $\text{Ø}\frac{1}{4}"\times 3\text{-}1/2"$ | BOLT | 4 |
| B |  $\text{Ø}\frac{1}{4}"\times 2\text{-}1/2"$ | BOLT | 4 |
| C |  $\text{Ø}\frac{1}{4}"\times 1\text{-}3/4"$ | BOLT | 2 |
| D |  | FLAT WASHER | 10 |
| E |  | SPRING WASHER | 10 |
| F |  | ALLEN WRENCH | 1 |
| G |  $\text{Ø}4\times 40\text{mm}$ | SCREW | 6 |

ALL PARTS ARE LABELED WITH STICKERS MATCHING THE PART IDENTIFICATION NUMBERS LISTED IN LEFT COLUMN.

IF ANY PARTS ARE MISSING OR DAMAGED IN THIS PACKAGE, LINON HOME DECOR WILL BE HAPPY TO PROVIDE YOU WITH REPLACEMENT PARTS, AT NO CHARGE, WITHIN 30 DAYS OF PURCHASE, PROVIDING THE PARTS ARE AVAILABLE IN OUR WAREHOUSE AND THE ITEM PURCHASED IS PART OF OUR CURRENT INVENTORY. IN ORDER TO RECEIVE SPARE PARTS, AT NO CHARGE, YOU MUST PROVIDE PROOF OF PURCHASE WITHIN 30 DAYS.

CALL US TOLL FREE AT 1-800-262-1852. OR VISIT OUR WEB SITE WWW.LINON.COM TO ORDER SPARE PARTS AND FOR CARE INSTRUCTIONS ON YOUR NEWLY PURCHASED FURNITURE.

IMPORTANT

PLEASE USE ALL THE HARDWARE MENTIONED ABOVE .
THEY WILL ASSURE THE ITEM STABILITY AND SAFETY.

TOOLS REQUIRED

A STANDARD PHILLIPS HEAD SCREWDRIVER (NOT PROVIDED) AND AN ALLEN WRENCH "F" (PROVIDED) ARE REQUIRED TO ASSEMBLE THIS UNIT. USE A PLASTIC HERD MALLET, NOT PROVIDED, TO TAP IN STRETCHERS OR OTHER COMPONENTS.



LINON HOME DÉCOR PRODUCTS, INC.

PART IDENTIFICATION:

| CODE | DESCRIPTION | QTY |
|------|-----------------|-----|
| 1 | CHAIR BACK | 1 |
| 2 | SEAT FRAME | 1 |
| 3 | FRONT RIGHT LEG | 1 |
| 4 | FRONT LEFT LEG | 1 |
| 5 | FRONT CROSSBAR | 1 |
| 6 | LEFT CROSSBAR | 1 |
| 7 | RIGHT CROSSBAR | 1 |

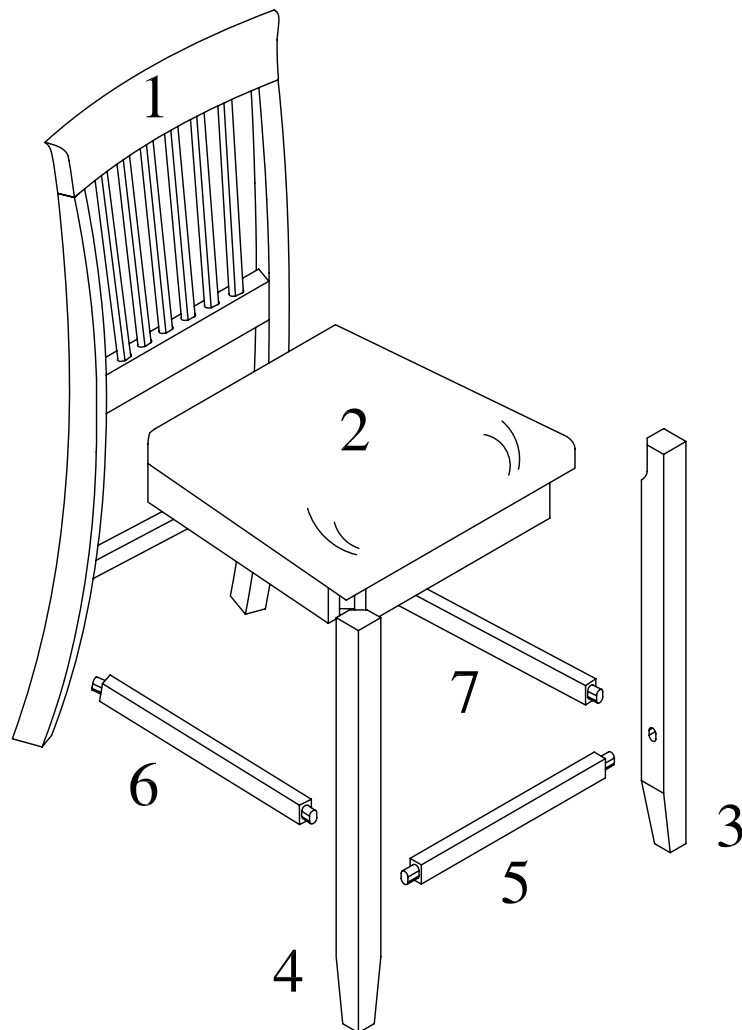



LINON HOME DÉCOR PRODUCTS, INC.

STEP 1

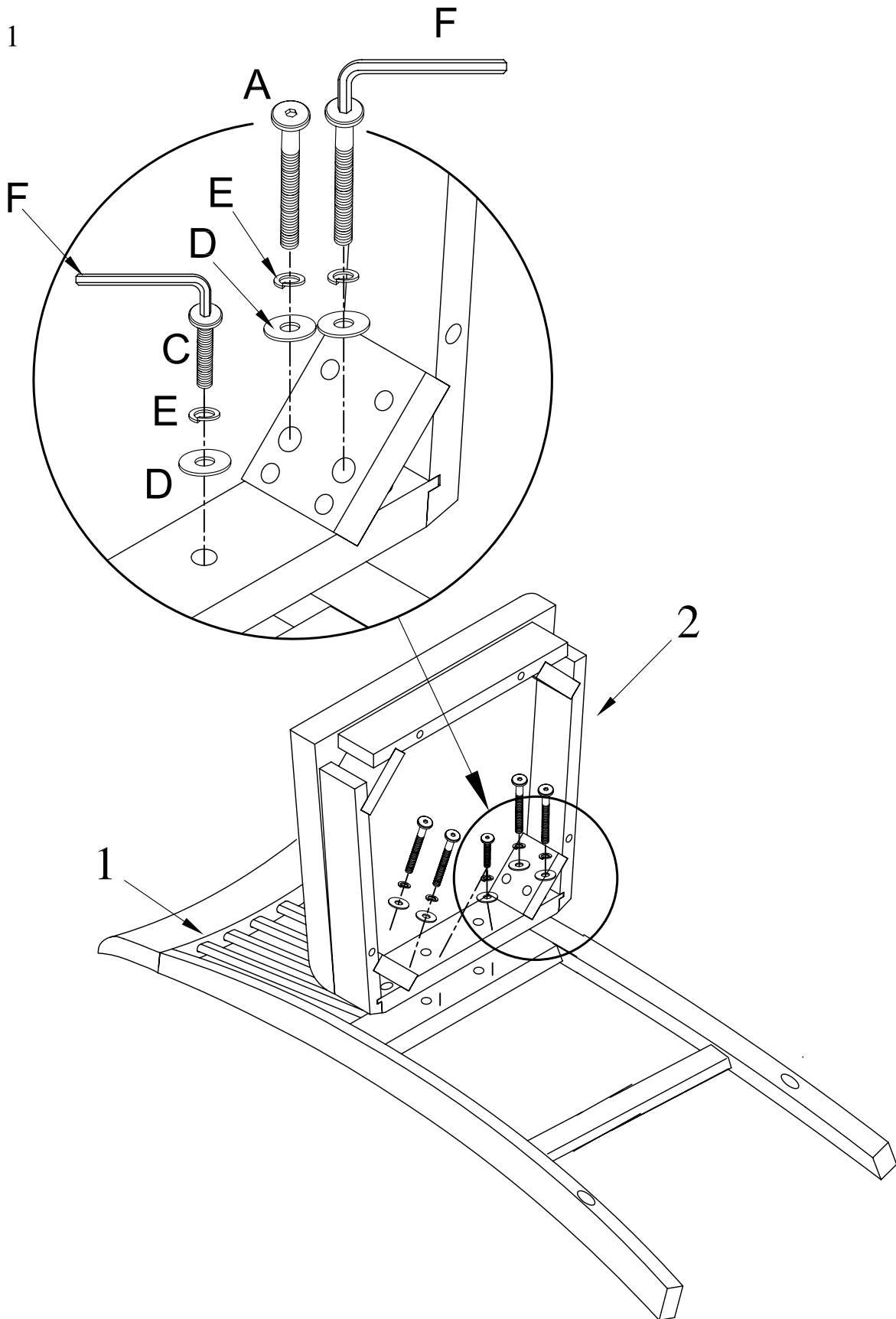



LINON HOME DÉCOR PRODUCTS, INC.

STEP 2

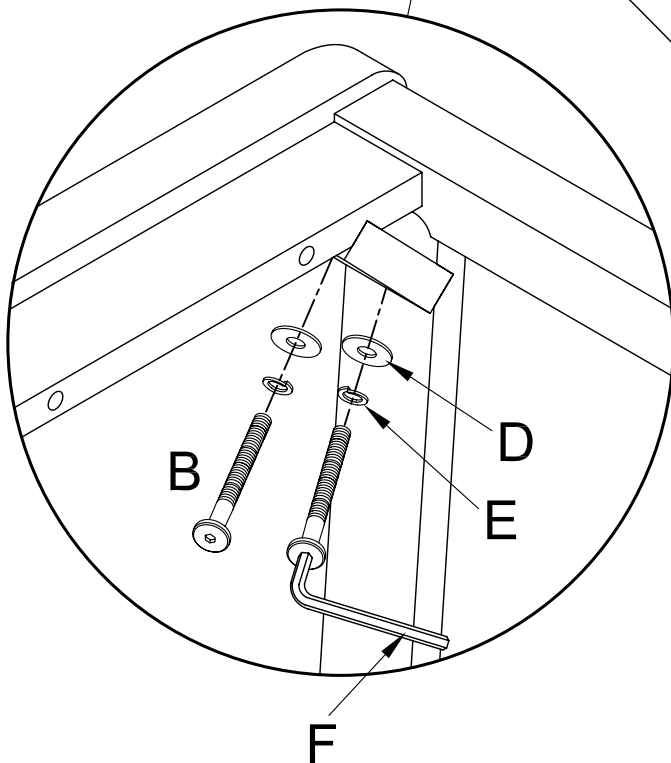
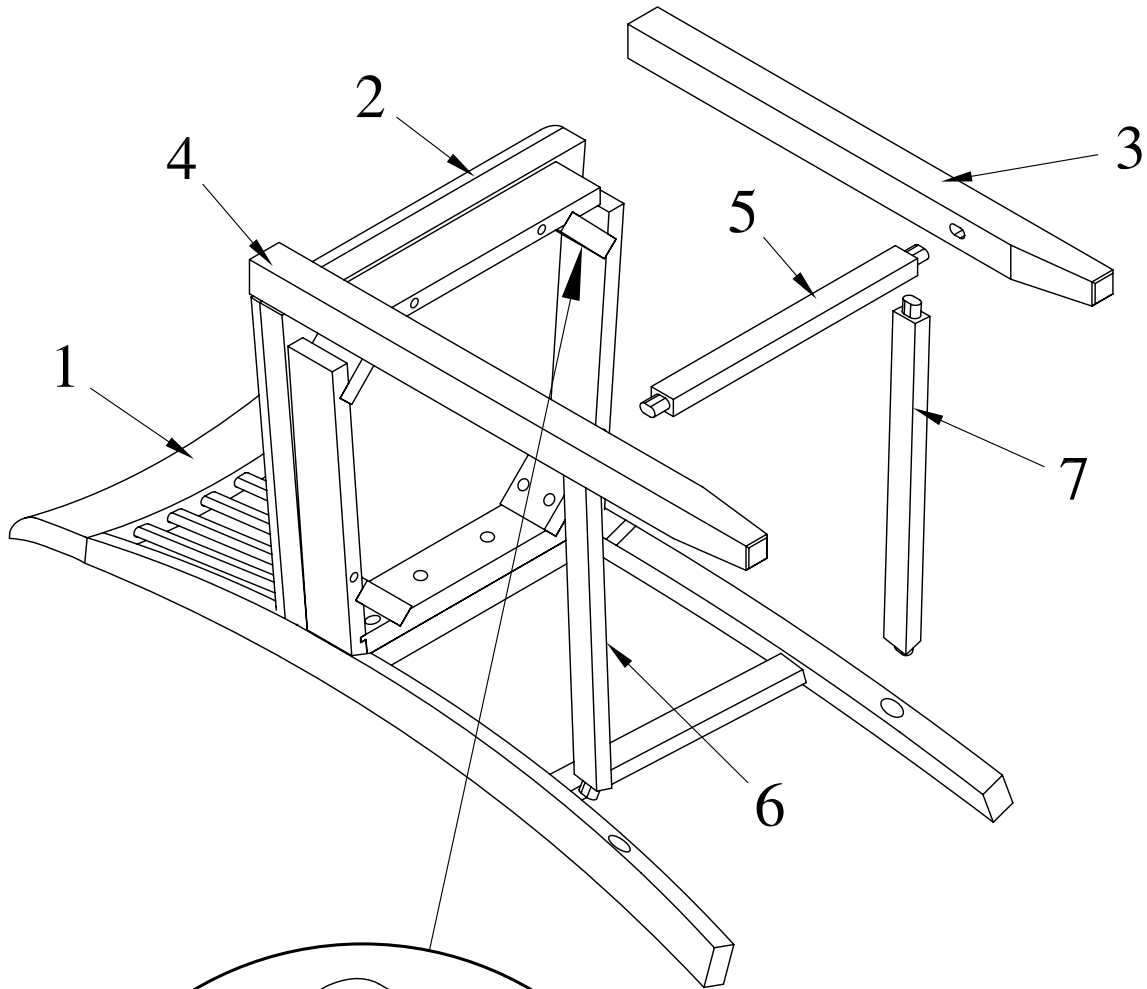



LINON HOME DÉCOR PRODUCTS, INC.

STEP 3

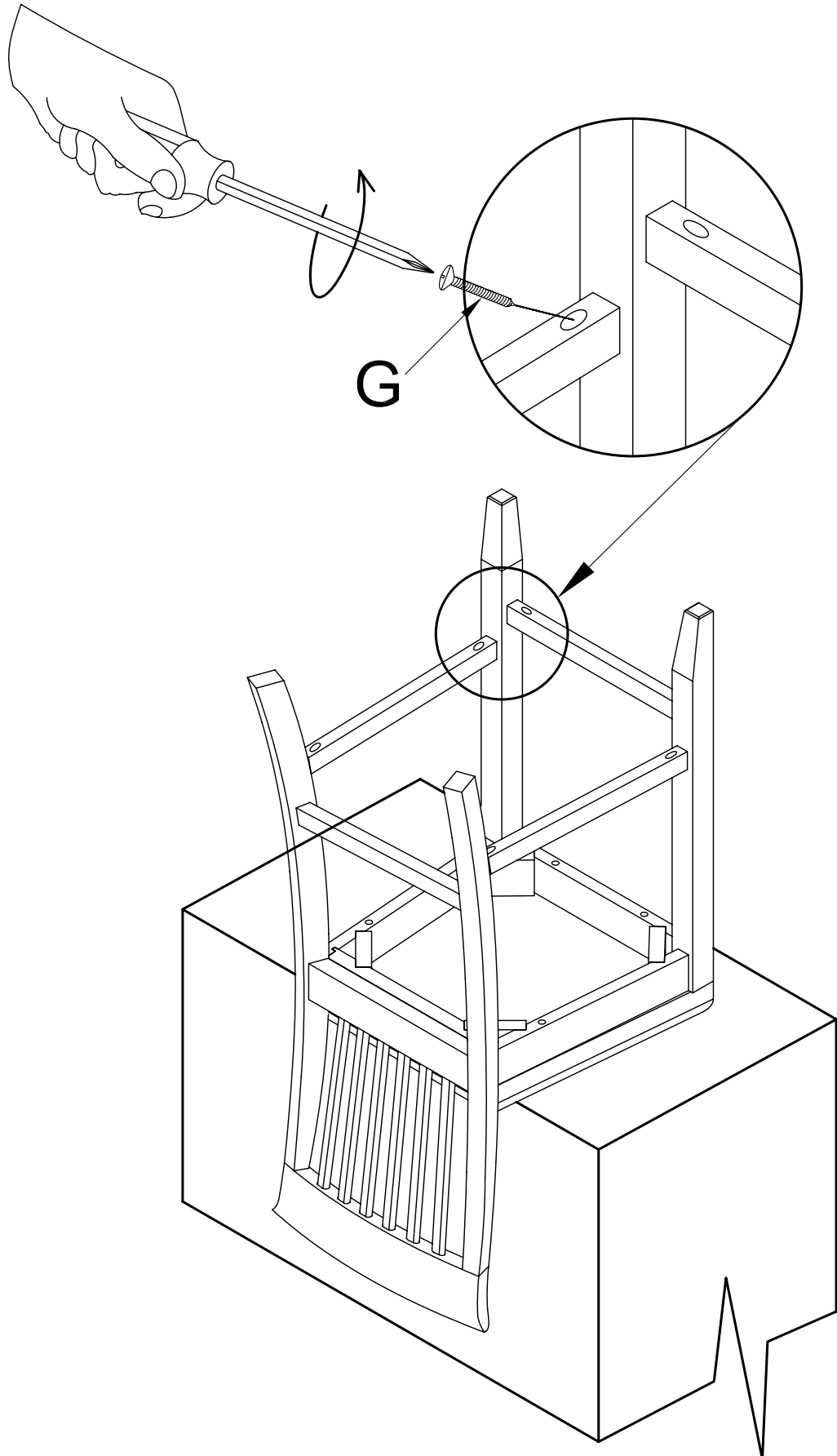



LINON HOME DÉCOR PRODUCTS, INC.

LIMITED 6 MONTHS WARRANTY

WHAT IS COVERED

This product is covered under our manufacturer's 6 months limited warranty (Linon homeDécor Products). To ensure your complete satisfaction, this warrants to the original purchaser that the Linon supplied item is free from defects in material and workmanship, as of the date of purchase , and that it will, under normal use and proper care, remain so for six months after the date of purchase.

Replacement of missing or initially defective parts will be sent, at no charge, for a period of 30 days from the date of purchase with valid proof of purchase providing the parts are available in our warehouse and the item purchased is part of our current inventory.

WHAT IS NOT COVERED

It remains the customer's responsibility for freight and packaging charges to and from the customer service center. Labor and material charges to remove or replace parts under this warranty are not covered.

This warranty does not cover furniture used for commercial purposes, failures caused by improper care, unreasonable or abusive use, freeze damage, acts of God, rust, purchased parts or return freight and packaging charges. Proof of purchase (dated register receipt) is required for warranty claims.

HOW TO OBTAIN SERVICE

For further information, please contact our customer service department, c/o Linon Home Décor Products, Inc, between 9:00 AM and 5:00 PM Eastern Standard Time, Monday through Friday.

**LINON HOME DÉCOR PRODUCTS, INC.
CUSTOMER SERVICE DEPARTMENT
22 JERICHO TURNPIKE
MINEOLA, NY. 11501**

Toll Free number : 1-800-262-1852 Customer Service
Visit our web site www.Linon.com to order spare parts and for care instructions on your newly purchased furniture.