

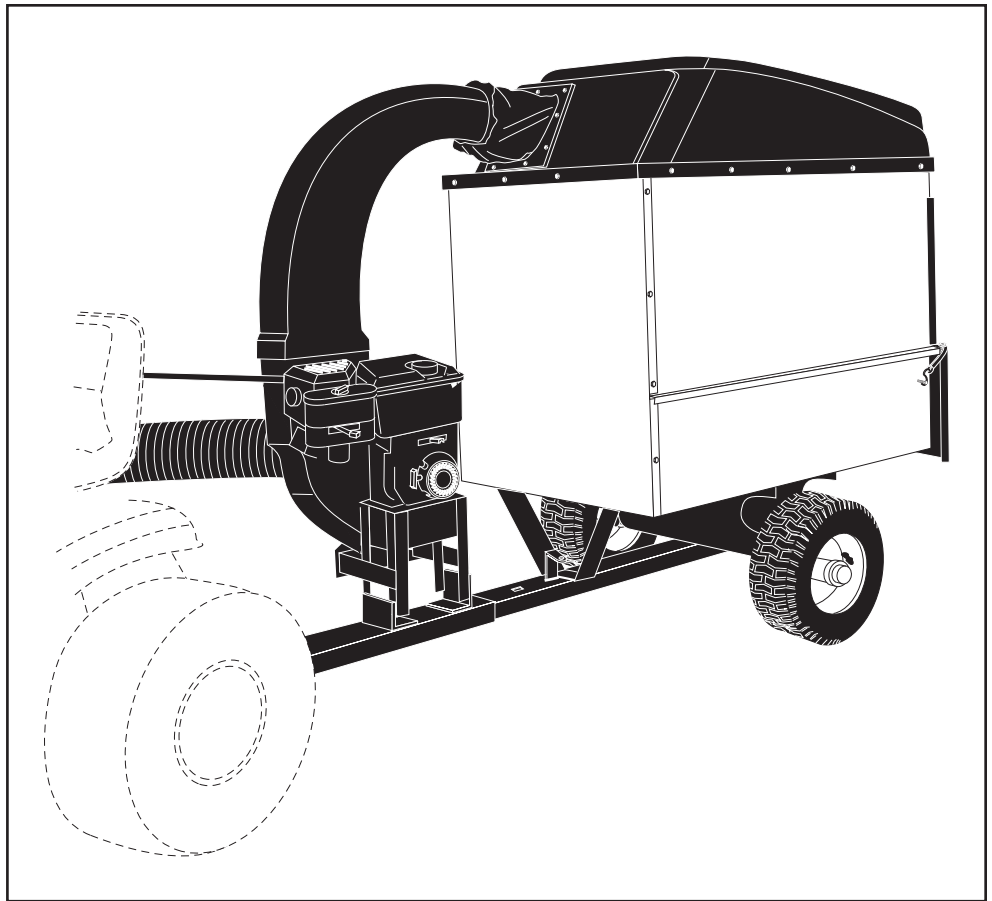

## OWNERS MANUAL

Model No's.  
551889  
190-217F-100

Includes Deck  
Adapter #62468



## MOW-N-VAC

**IMPORTANT:** The engine is shipped without oil. Add oil before starting the engine.

**IMPORTANT:** The wheel bearings are not prelubricated. Fill the wheel hubs with grease after assembling the wheels to the axle.

**CAUTION:**  
Read Rules for  
Safe Operation  
and Instructions  
Carefully

- **Safety**
- **Assembly**
- **Operating**
- **Maintenance**
- **Repair Parts**



Want more information or assembly tips?  
Scan with free ShowUHow Mobile App  
available at iTunes Store or Android Market.

Or visit [www.agri-fab.com](http://www.agri-fab.com) for product  
assembly instructions.

Call 1-800-448-9282 for missing parts or assembly help.

**SpeedPart** *the fastest way to purchase parts* [www.speedpart.com](http://www.speedpart.com)

# TABLE OF CONTENTS

SAFETY RULES.....	3,4	STORAGE .....	16
FULL SIZE HARDWARE CHART .....	5,13	TROUBLESHOOTING.....	17
CARTON CONTENTS.....	6	REPAIR PARTS ILLUSTRATIONS .....	19,20,22
ASSEMBLY .....	7	REPAIR PARTS LISTS .....	19,21,22
OPERATION.....	15	SLOPE GUIDE .....	23
MAINTENANCE .....	16	PARTS ORDERING.....	24

## OPTIONAL ACCESSORY MODEL NO. 45-0253 12 FT. REMOTE HOSE KIT

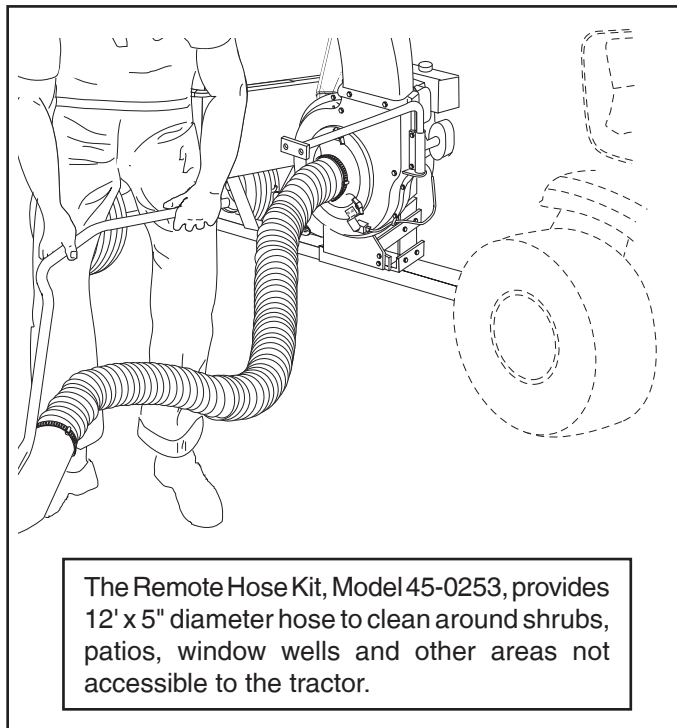

## WARNING

This unit is equipped with an internal combustion engine and should not be used on or near unimproved forest-covered, or grass-covered land unless the engine's exhaust system is equipped with a spark arrester meeting applicable local or state laws (if any). If a spark arrester is used, it should be maintained in effective working order by the operator.

In the State of California the above is required by law (Section 4442 of the California Public Resources Code). Other states may have similar laws. Federal laws apply on federal lands. A spark arrester muffler is available at you nearest engine authorized service center.



## SAFETY



Any power equipment can cause injury if operated improperly or if the user does not understand how to operate the equipment. Exercise caution at all times, when using power equipment.

- Read and follow all instructions in this manual before attempting to assemble or operate this equipment. Failure to comply with these instructions may result in personal injury. Keep this manual in a safe place for future reference and for ordering replacement parts.
- Read this operating and service instruction manual carefully. Be thoroughly familiar with the controls and proper use of this power vacuum.
- Read the vehicle owners manual and vehicle safe operation rules before using this equipment.
- Never allow children under 16 to operate this Mow-N-Vac. Children 16 years and older should only operate under close parental supervision.
- Do not allow anyone to operate this equipment without proper instructions.
- Do not allow passengers to ride on this equipment or on the towing vehicle.
- Keep the area of operation clear of all persons, particularly small children. Also keep area clear of pets.
- Check fuel before starting engine. Do not fill fuel tank indoors, or when engine is running, or while engine is hot. Wipe off any spilled fuel before starting engine.
- Engine and muffler get hot. Do not touch! To avoid fire hazard, keep clean of debris and other accumulations.
- Never store Mow-N-Vac with fuel in tank. Allow engine to cool before storing in any enclosure.
- Do not change engine governor settings.
- Do not operate engine if air cleaner or cover is removed, except for adjustment. Removal of these parts could create a fire hazard.
- Keep hands, feet, face, long hair and clothing out of inlet and discharge area. There are ROTATING BLADES inside these openings.
- Before cleaning, repairing or inspecting, make certain all moving parts come to a complete stop. Disconnect spark plug wire and keep wire away from plug to prevent accidental starting. Keep throttle control lever in stop position.
- If the Mow-N-Vac should become blocked with debris at any point, shut engine off and wait until the impeller comes to a complete stop before attempting to remove the obstruction. Disconnect spark plug wire to prevent accidental starting.
- If the cutting mechanism strikes a foreign object, or if your Mow-N-Vac should start to vibrate abnormally, stop the engine immediately, disconnect the spark plug wire and move the wire away from the spark plug. Allow the machine to stop and take the following steps.
  - a. Inspect for damage.
  - b. Repair or replace any damaged parts.
  - c. Check for loose parts and tighten to assure continued safe operation.
- Check all bolts for tightness at frequent intervals to help insure safe operation.
- Check vinyl hard top boot frequently for wear. Replace if worn or damaged.
- Never operate Mow-N-Vac unless deck adapter, hose, hose adapter (nozzle), discharge chute (elbow), and top cover are properly attached in their place.
- Do not remove top cover or attempt to empty contents of cart while engine is running.
- Never attempt to change hose adapter (nozzle) or to install remote hose attachment when engine is running.
- Keep all shields and guards (e.g. discharge chute (elbow) and hose adapter (nozzle) in place and securely attached.
- Always wear safety glasses or other suitable eye protection when operating or maintaining this equipment.
- Do not stand behind cart in exhaust discharge area while engine is running.
- Do not operate this equipment while intoxicated or while taking drugs or medication that impairs the senses and reactions.
- When using this equipment, start with the vehicle transmission in first (low) gear and then gradually increase speed only as conditions permit.
- Operate this equipment at reduced speed on rough terrain, along creeks and ditches and on slopes to prevent tipping or loss of control. Do not drive too close to a creek or ditch.
- Vehicle braking and stability are affected by the addition of this equipment. Do not fill the Mow-N-Vac to its full capacity without checking the capability of the towing vehicle to safely pull and stop with the Mow-N-Vac attached.
- Before operating on any grade (hill) refer to the safety rules in the vehicle owner's manual concerning safe operation on slopes. Also refer to the SLOPE GUIDE on page 23 of this owner's manual. Do not operate on slopes in excess of 10 degrees. **STAY OFF STEEP SLOPES.**
- Follow the maintenance instructions outlined in this manual.



Look for this symbol to point out important safety precautions. It means — **Attention!! Become alert!! Your safety is involved.**



**DANGER:** This Mow-N-Vac was built to be operated according to the rules for safe operation in this manual. As with any type of power equipment, carelessness or error on the part of the operator can result in serious injury. This unit is capable of amputating fingers and hands and throwing objects. Failure to observe the following safety instructions could result in serious injury or death.

# **WARNING**

## **TO AVOID SERIOUS INJURY**

- Read Owner's Manual and all safety labels on machine before starting and using machine.
- Do Not remove top cover or attempt to empty contents of cart while engine is running.
- Do Not stand behind cart in exhaust discharge area while engine is running.
- Keep hands, feet, face, long hair and clothing out of chipper inlet, vac inlet, and discharge area. There are **ROTATING BLADES** inside these openings.
- Wear approved safety glasses and gloves. Avoid loose fitting clothes.
- Keep the area of operation clear of all persons, particularly small children and pets.
- Keep all shields and guards (e.g. upper chipper chute extension, discharge chute, nozzle assembly) in place and securely attached.
- Check discharge boot frequently for wear. Replace if worn or damaged.
- If unit becomes clogged or jammed, shut off engine right away. Do Not attempt to clear clog or jam with engine running.
- Muffler and engine get hot and can cause burns. Do Not Touch. To avoid a fire hazard, keep leaves, grass and other combustible debris off hot muffler and engine.
- Do Not attempt to remove or attach vac nozzle or optional Hose Kit with engine running.
- Do Not operate unit unless nozzle or optional Hose Kit is secured in place.
- Do Not fill gas tank while engine is running. Allow engine to cool at least 2 minutes before refueling.



## **DANGER**

**HAZARDOUS ROTATING BLADES INSIDE. KEEP HANDS AWAY FROM ALL OPENINGS. DO NOT REMOVE OR ATTACH HOSE, HOSE ADAPTER, ELBOW OR OPTIONAL HOSE KIT WHEN ENGINE IS RUNNING!**



### **WARNING**

**MUFFLER AND  
ADJACENT AREAS  
MAY EXCEED 150 F**

777-5863

## **NOTICE**

**ENGINE WILL NOT RUN  
WITHOUT HOSE ADAPTER INSTALLED  
ON BLOWER HOUSING  
(SEE OWNERS MANUAL)**

## **AVISO**

**EL MOTOR NO FUNCIONARÁ  
SIN INSTALACIÓN DEL ADAPTADOR  
DE LA MANGUERA SOBRE  
LA CUBIERTA DEL SOPLADOR  
(VEA EL MANUAL DE OPERADOR)**

# HARDWARE PACKAGE CONTENTS

## SHOWN FULL SIZE

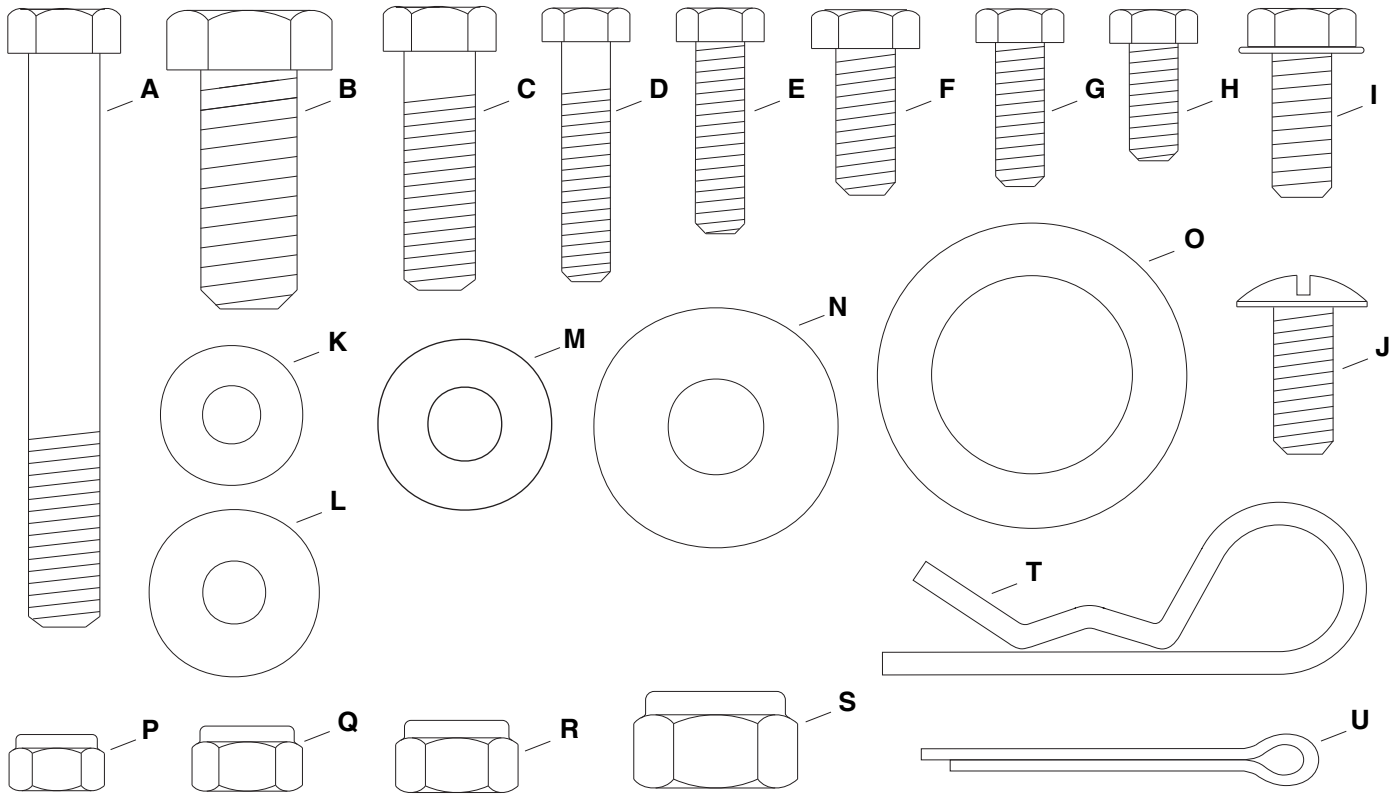

## NOT SHOWN FULL SIZE

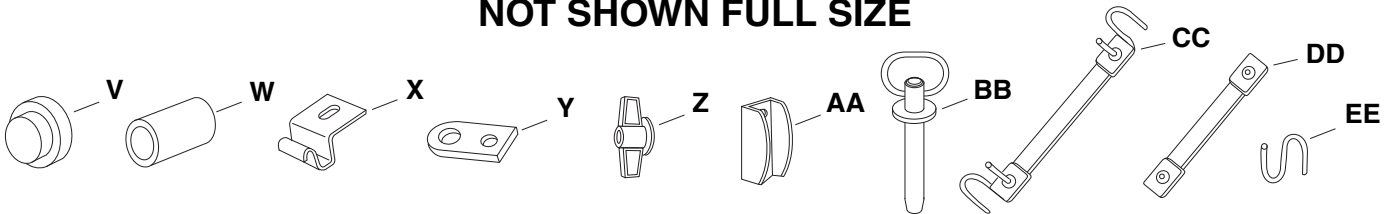

See page 13 for contents of Deck Adapter hardware package. (Contents not included here.)

REF.	PART NO.	QTY.		DESCRIPTION	REF.	PART NO.	QTY.		DESCRIPTION
		Cart	Vac				Cart	Vac	
A	43574	3	—	Bolt, Hex 3/8" x 3"	Q	47810	12	6	Nylock Hex Nut, 5/16"
B	43351	—	1	Bolt, Hex 1/2" x 1-1/4"	R	HA21362	5	—	Nylock Hex Nut, 3/8"
C	43087	2	—	Bolt, Hex 3/8" x 1-1/4"	S	712-3083	—	1	Nylock Hex Nut, 1/2"
D	1509-90	—	5	Bolt, Hex 1/4" x 1-1/4"	T	43343	1	—	Pin, Hair Cotter 1/8"
E	43661	—	2	Bolt, Hex 1/4" x 1"	U	43093	2	—	Pin, Cotter 1/8" x 1-1/2"
F	43182	—	6	Bolt, Hex 5/16" x 3/4"	V	43014	2	—	Hub Cap
G	43012	—	14	Bolt, Hex 1/4" x 3/4"	W	44678	2	—	Spacer Tube
H	43866	9	20	Bolt, Hex 1/4" x 5/8"	X	23838	2	—	Door Support
I	47630	—	4	Bolt, Hex 5/16" x 3/4" (ST)	Y	23540	—	1	Hitch Plate
J	43814	12	—	Bolt, Truss Head 5/16" x 3/4"	Z	712-0421	—	3	Knob
K	43088	2	36	Washer, Flat 1/4"	AA	23789	—	2	Door Latch
L	1543-69	—	6	Washer, Nylon	BB	43884	1	—	Hitch Pin
M	43081	—	4	Washer, Flat 5/16"	CC	43790	—	1	Tarp Strap, 25"
N	43352	—	1	Washer, Flat 7/16"	DD	44850	—	4	Tarp Strap (Less Hooks)
O	43601	4	—	Washer, Flat 1"	EE	44849	—	4	"S" Hooks
P	47189	9	40	Nylock Hex Nut, 1/4"					

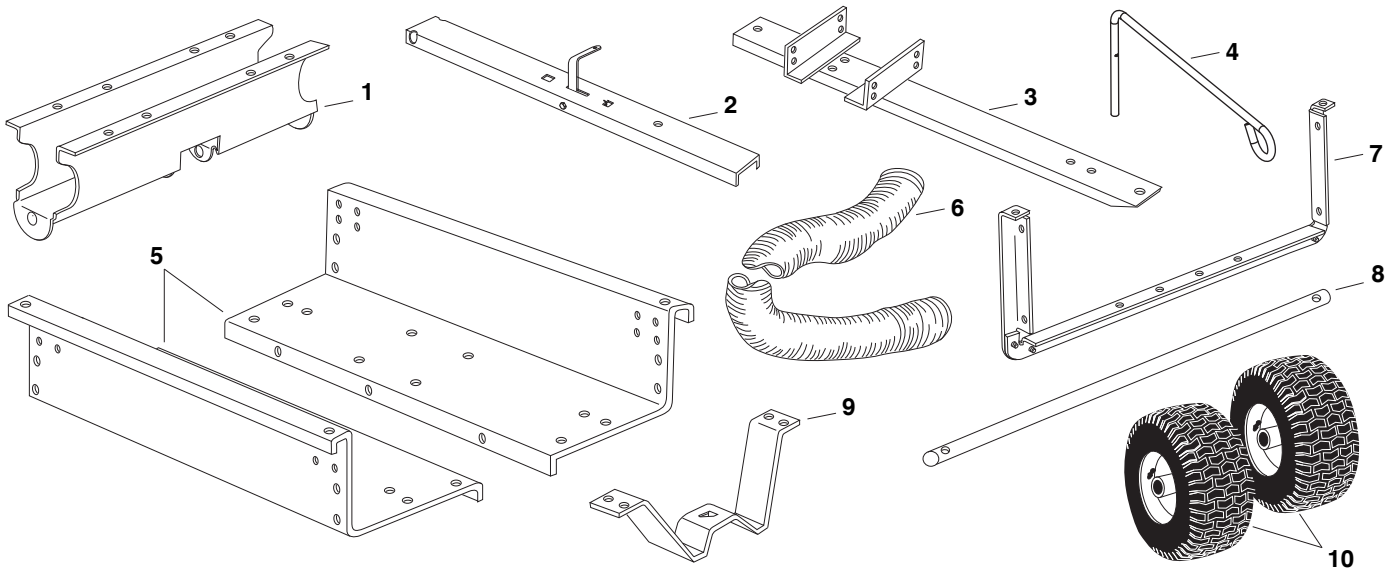

**CARTON CONTENTS (Cart Body Carton)**

REF.	PART NO.	QTY.	DESCRIPTION	REF.	PART NO.	QTY.	DESCRIPTION
1	23507	1	Wheel Support	6	41882	1	Hose
2	----	1	Rear Tongue w/Latch	7	62458	1	Tailgate Reinforcement Bracket
3	63155	1	Front Tongue	8	24897	1	Axle
4	49974	1	Hose Hanger Rod	9	24497	1	Latch Stand Bracket
5	23985	2	Cart Body	10	42159	2	Wheels

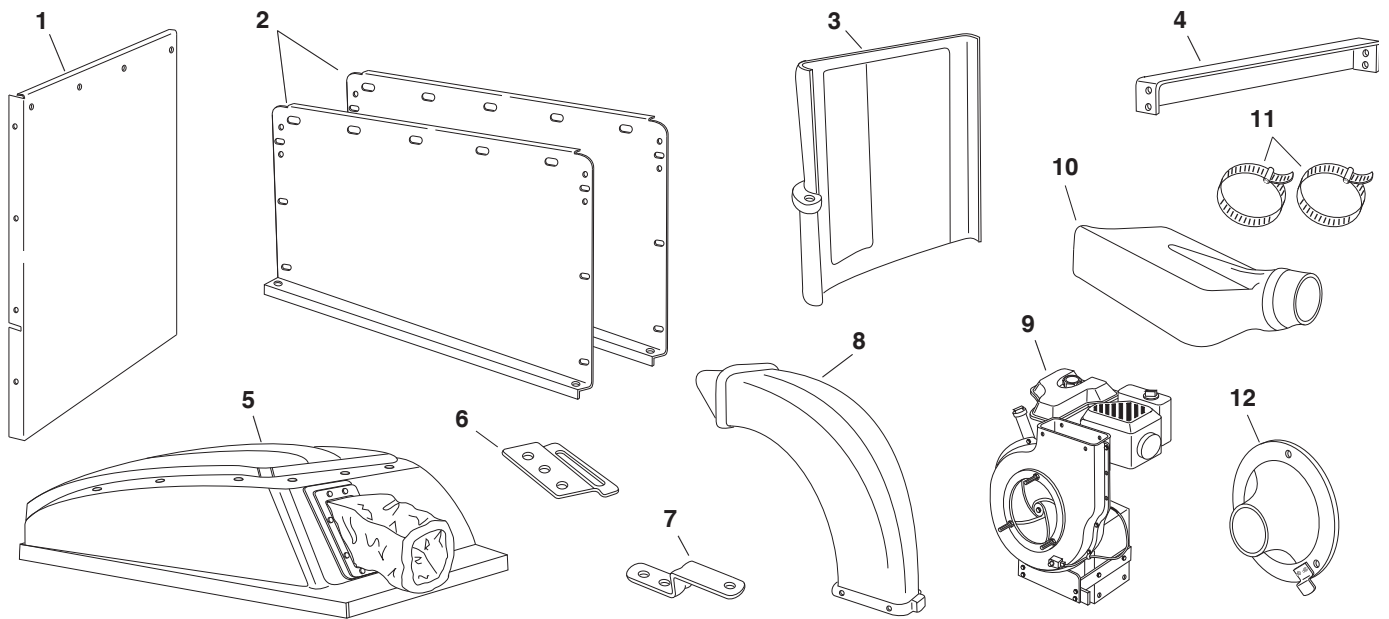

**CARTON CONTENTS (Mow-N-Vac Carton)**

REF.	PART NO.	QTY.	DESCRIPTION	REF.	PART NO.	QTY.	DESCRIPTION
1	24679	1	Front Panel	8	46420	1	Elbow
2	24678	2	Side Panels	9	----	1	Engine Base Assembly
3	44790	1	Rear Door	10	43830	1	Deck Adapter
4	23836	1	Cross Brace	11	43793	2	Hose Clamp
5	64244	1	Poly Hard Top	12	43791	1	Hose Adapter (Nozzle)
6	23560	1	Adapter Bracket				
7	23475	1	Hitch Bracket				

# ASSEMBLY

This unit is shipped WITHOUT GASOLINE or OIL. After assembly, see separate engine manual for proper fuel and engine oil recommendations.

## TOOLS REQUIRED FOR ASSEMBLY

- (1) Screwdriver
- (1) Pliers
- (2) 7/16" Wrenches
- (2) 1/2" Wrench
- (2) 9/16" Wrenches
- (2) 3/4" Wrenches (only if figure 22 on page 12 is used)

## REMOVAL OF PARTS FROM CARTONS

1. Remove the hardware packs and all loose parts from the cartons.
2. Lay out and identify parts shown in carton contents.
3. Lay out and identify parts in the hardware packs. Keep contents of each hardware package separate.

## ASSEMBLING CART BODY

1. Place cart body halves upright on a smooth level surface such as a garage floor or a paved driveway. See figure 1.



**CAUTION:** Do not leave the cart unattended in upright position during assembly. A falling cart can cause personal injury! Pay close attention to the stability of the cart while it remains in an upright position. For best stability, assemble on a smooth level surface.

2. Assemble cart body halves together using three 1/4" x 5/8" hex bolts and 1/4" Nylock hex nuts as shown in figure 1. **Do not tighten yet.**

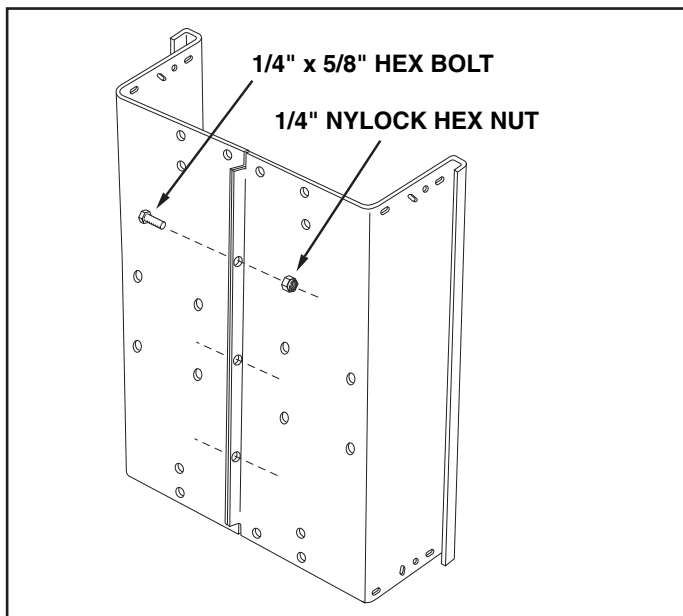

FIGURE 1

3. Fit the tailgate reinforcement bracket over the end of the cart bed. Position the two door support brackets on the bottom of the reinforcement bracket as shown in figure 2. Fasten the reinforcement bracket and the door supports to the bottom of the cart using four 5/16" x 3/4" truss head bolts and 5/16" Nylock hex nuts. **Do not tighten yet.** See figure 2.
4. Fasten the tailgate reinforcement bracket to the sides of the cart body using four 1/4" x 5/8" hex bolts and 1/4" Nylock hex nuts as shown in figure 2. **Do not tighten yet.**

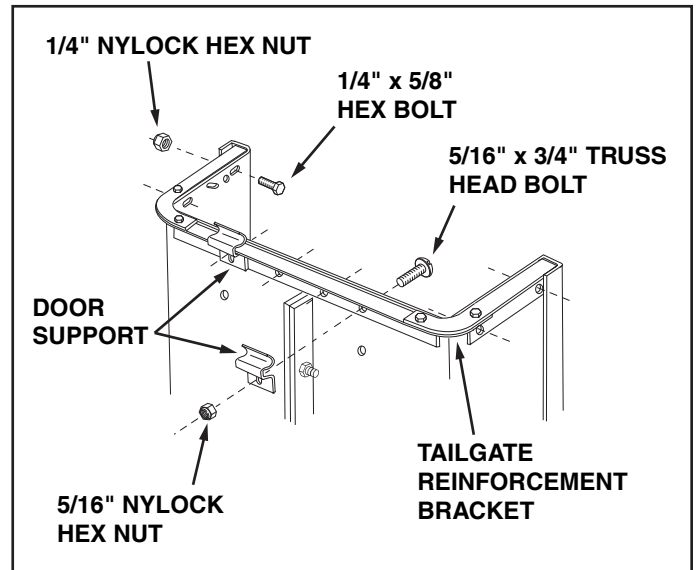

FIGURE 2

5. Pull the cart body halves together. **Tighten** the four truss head bolts in figure 2. **Tighten** the four hex bolts in figure 2. **Tighten** the three hex bolts in figure 1, keeping the bottom aligned and pulled together.
6. Carefully flip the cart end for end so that it rests on the tailgate reinforcement bracket. See figure 3.

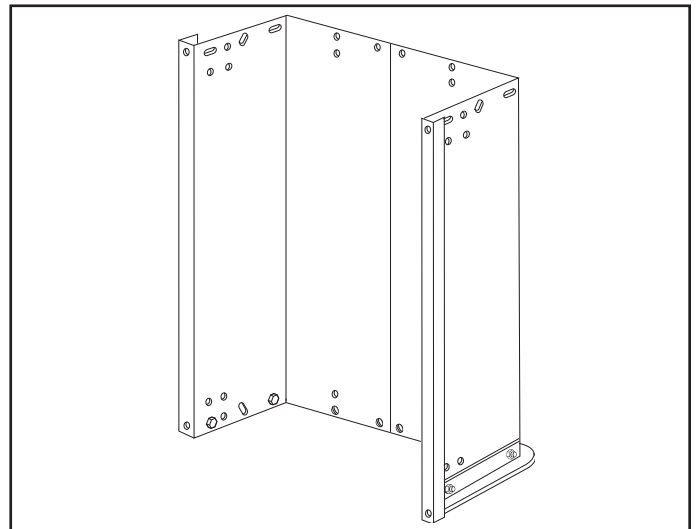

FIGURE 3

7. Assemble the wheel support to the bottom of the cart using eight 5/16" x 3/4" truss head bolts and 5/16" Nylock hex nuts as shown in figure 4. Heads of bolts go on the inside of cart. **Tighten.**

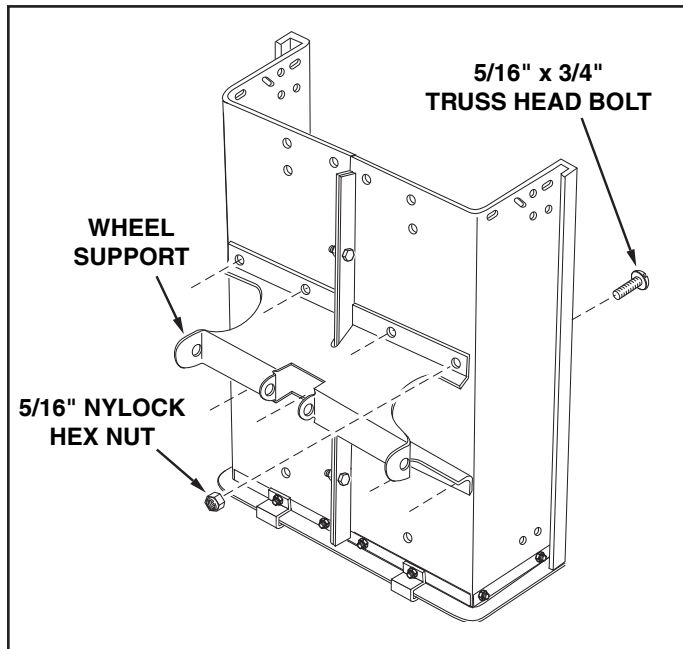

FIGURE 4

8. To prevent accidental tipping during the following assembly procedures, lower the cart to rest upside down, with the wheel support facing up, as shown in figure 5.
9. Align the latch stand bracket so that the tab is at the rear. Fasten the bracket to the rear set of holes at the front of the cart using two 1/4" x 5/8" hex bolts, 1/4" flat washers and 1/4" Nylock hex nuts. Use the 1/4" flat washers as shims between the bracket and the cart bed. **Make finger tight.** See figure 5.

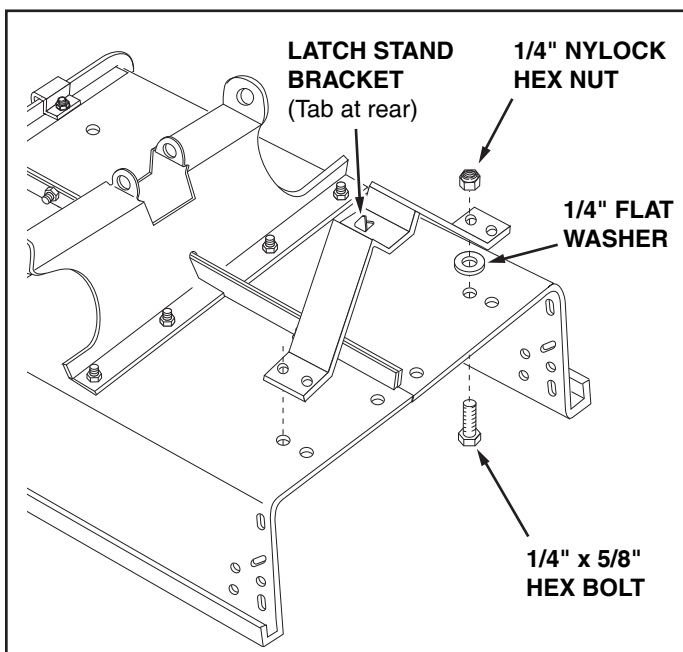

FIGURE 5

10. Position the rear tongue on the wheel support and the latch stand bracket. Assemble the axle through the wheel support and the tongue. See figure 6.

**IMPORTANT:** Make sure the tongue is securely locked to the latch stand bracket by the latch lock lever.

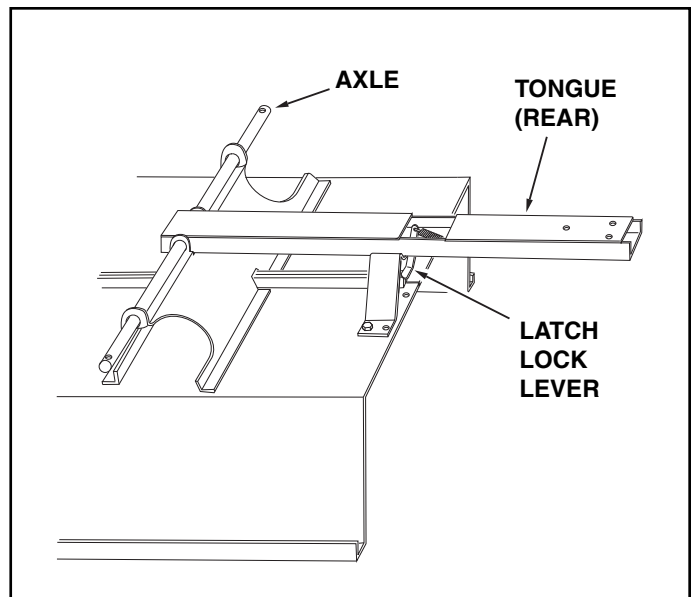

FIGURE 6

11. Assemble a spacer tube, a 1" flat washer, a wheel (valve stem facing out), and another 1" flat washer onto the axle as shown in figure 7. Secure the wheel with a cotter pin, spreading the ends so that a hub cap can fit over the pin. Assemble the hub cap by pressing it onto the flat washer. Repeat on other end of axle.
12. Pump grease into grease fittings on wheels until grease is forced out through ends of hubs.

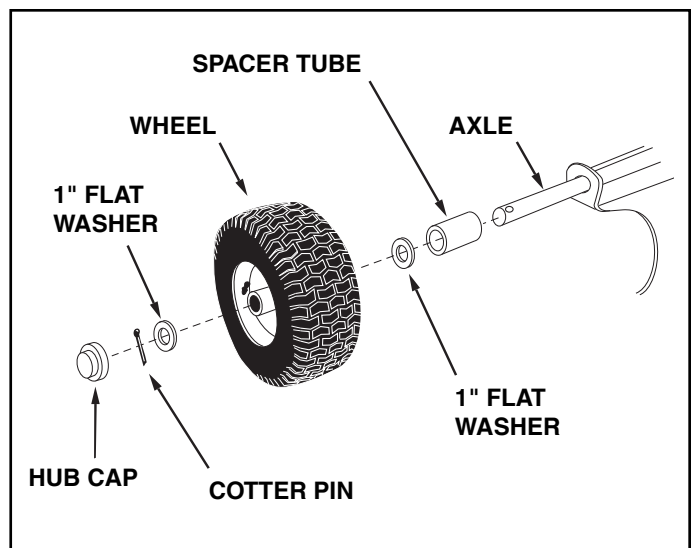

FIGURE 7

13. Flip the cart over so that it rests on its wheels.

14. Assemble the front tongue on top of the rear tongue using three 3/8" x 3" hex bolts and 3/8" Nylock hex nuts. See figure 8.

**HINT:** For easier assembly, support the rear tongue with a block of wood.

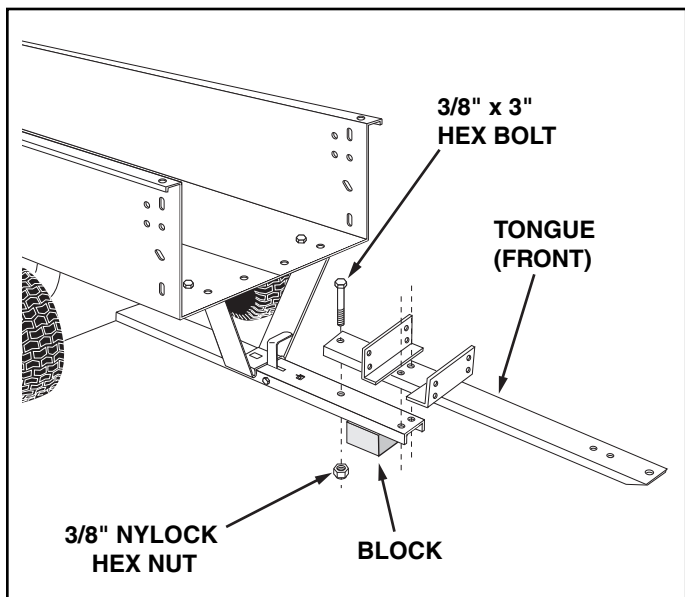

FIGURE 8

15. Assemble the hitch bracket to the front tongue using two 3/8" x 1-1/4" hex bolts, 3/8" and 3/8" Nylock hex nuts. **Tighten.** See figure 9.

16. Secure the hitch pin to the hitch bracket and tongue with the hair cotter pin. See figure 9.

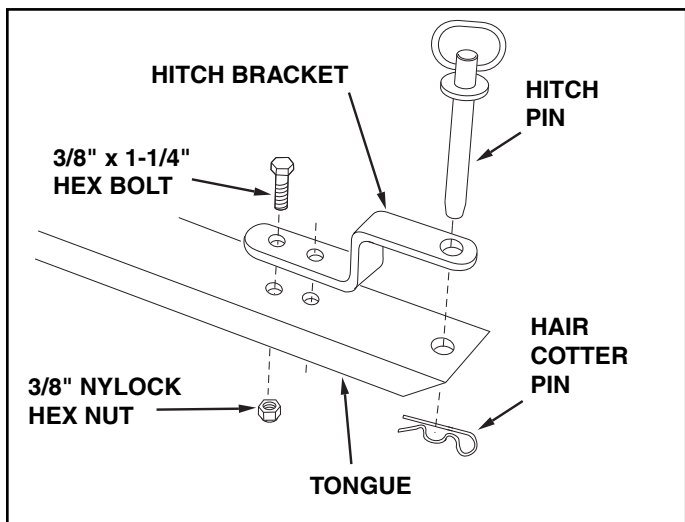

FIGURE 9

## ASSEMBLING VAC PARTS

17. Release the latch lock lever and tilt the cart bed back. See figure 10.

18. Assemble the front panel to the cart bed, sliding the bottom lip of the panel in between the cart bed and the latch stand bracket. Fasten the panel to the bottom and sides of the cart bed using six 1/4" x 5/8" hex bolts and 1/4" Nylock hex nuts. **Tighten.** See figure 10.

19. **Tighten** the two bolts that you assembled to the latch stand bracket in figure 5.

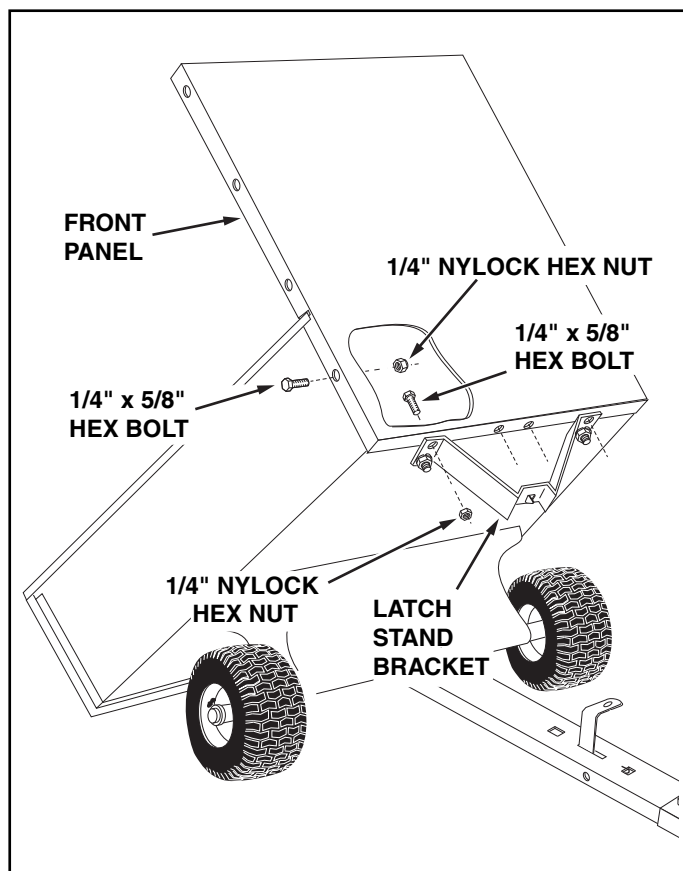

FIGURE 10

20. Place a side panel on top of the cart bed flange, inside the lip of the front panel. Fasten the side panel to the front panel using three 1/4" x 5/8" hex bolts and 1/4" Nylock hex nuts. Fasten the side panel to the cart bed flange using two 1/4" x 5/8" hex bolts, 1/4" flat washers, and 1/4" Nylock hex nuts. **Tighten**. See figure 11. Repeat on other side.

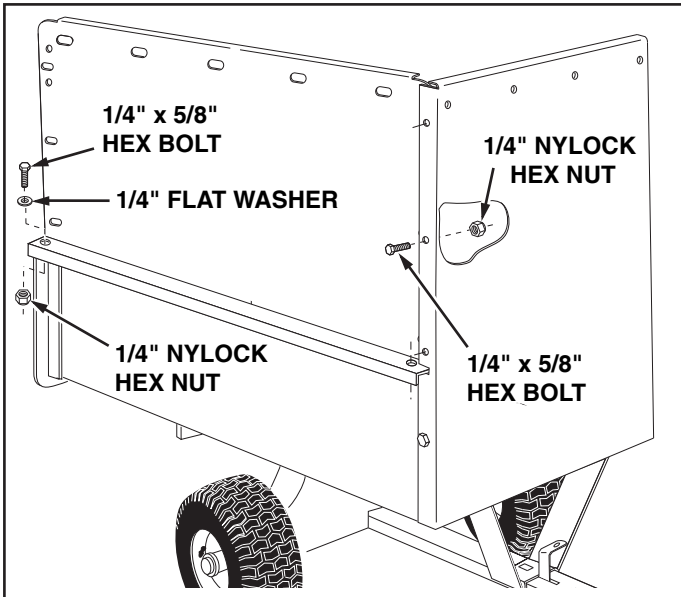

FIGURE 11

21. Screw a 1/4" Nylock hex nut approximately half an inch onto a 1/4" x 1" hex bolt. Insert the bolt into the hole shown in figure 12, in the side of the cart. Fasten the bolt to the cart using a 1/4" Nylock hex nut. **Tighten** so that the nut is flush with the end of the bolt. Repeat on the other side. See figure 12.

22. Assemble the cross brace to the top rear holes in the side panels using four 1/4" x 5/8" hex bolts and 1/4" Nylock hex nuts. See figure 12.

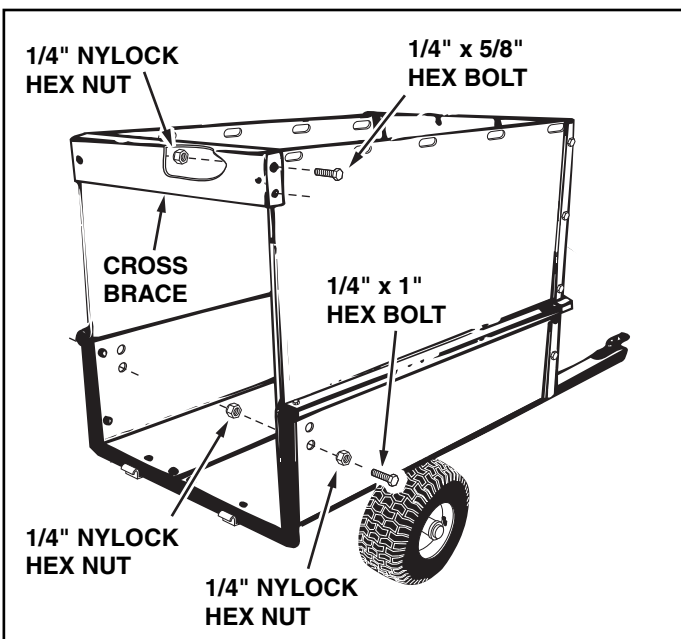

FIGURE 12

23. Assemble a door latch at each end of the cross brace using a 5/16" x 3/4" hex bolt, a nylon washer and a 5/16" Nylock hex nut. Place the nylon washer between the door latch and cross brace. **Tighten** so that latch is snug but will still rotate. See figure 13.

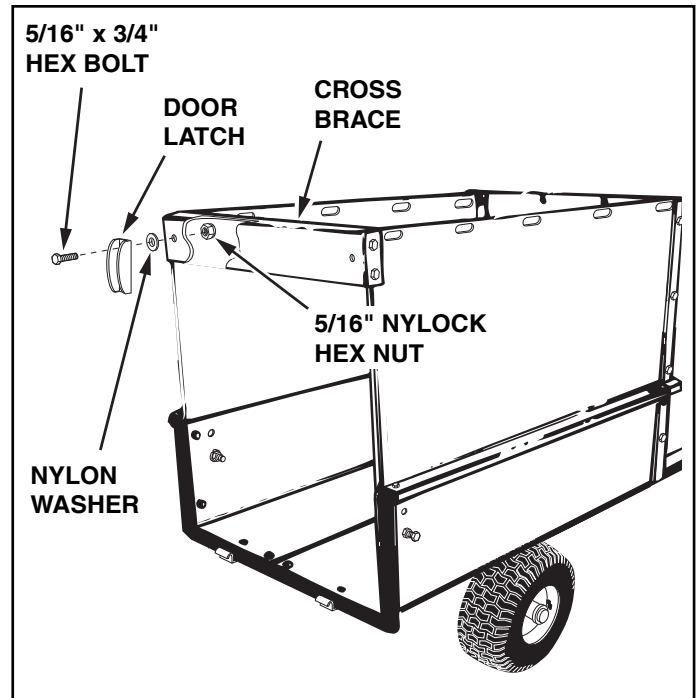

FIGURE 13

24. Install the poly hard top using fourteen 1/4" x 3/4" hex bolts and 1/4" flat washers on the outside and fourteen 1/4" flat washers and 1/4" Nylock hex nuts on the inside. **Tighten**. See figure 14.

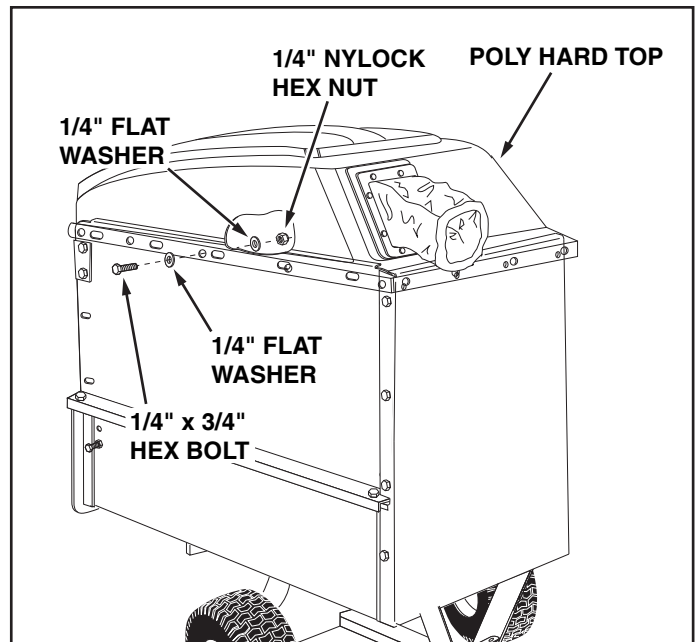

FIGURE 14

25. Assemble a short tarp strap to rear door using one 1/4" x 1-1/4" hex bolt, two 1/4" flat washers and one 1/4" Nylock hex nut. Assemble an "S" hook through loose end of strap. See figure 15. Repeat on other side of door.
26. Assemble door to rear of cart by resting bottom of door on door supports and pushing top of door in against cross brace. Secure top of door using door latches on each side. See figure 15.
27. Hook both the tarp straps onto the 1/4" x 1" hex bolts in the sides of the cart. See figure 15.

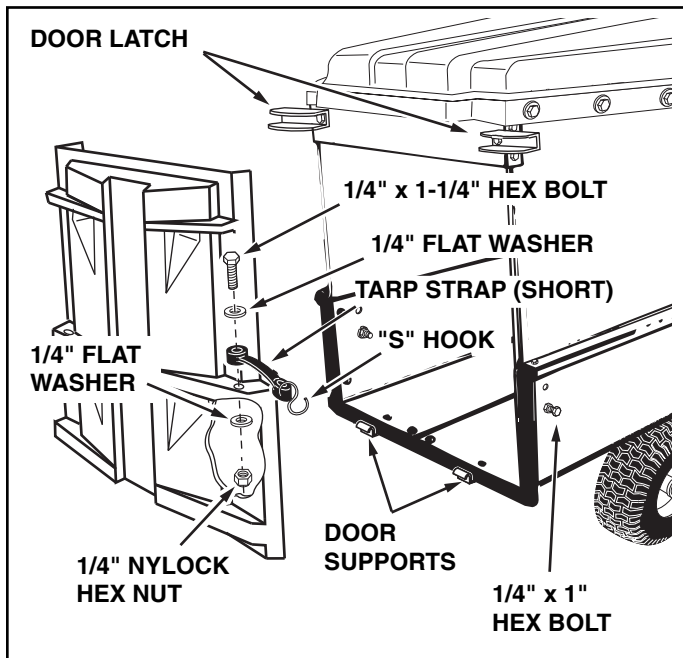

FIGURE 15

28. Attach the engine/impeller housing assembly to the **upper** slots in the angles welded to the tongue. Use four 5/16" x 3/4" hex bolts, 5/16" flat washers and 5/16" nylock nuts. Washers go between bolt heads and slots in welded angles. **Tighten**. See figure 16.

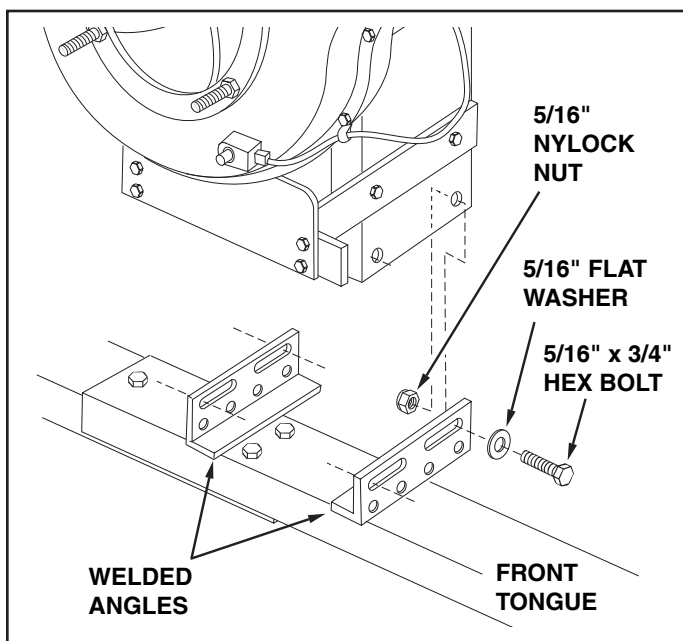

FIGURE 16

29. Assemble the elbow to the impeller housing using four 5/16" x 3/4" self tapping hex bolts and four nylon washers. Push while turning to help start the bolts into the unthreaded holes. **Tighten**. See figure 17.
30. To center the elbow with the opening in the hard top:
  - a. Push the vinyl boot back inside the opening.
  - b. Loosen by approximately 1/2 turn each, the four bolts that you assembled in figure 16.
  - c. Slide the engine in the slots until the elbow is centered with the opening in the hardtop.
  - d. **Retighten** the four bolts that you loosened.
31. Pull the vinyl boot onto the end of the elbow.

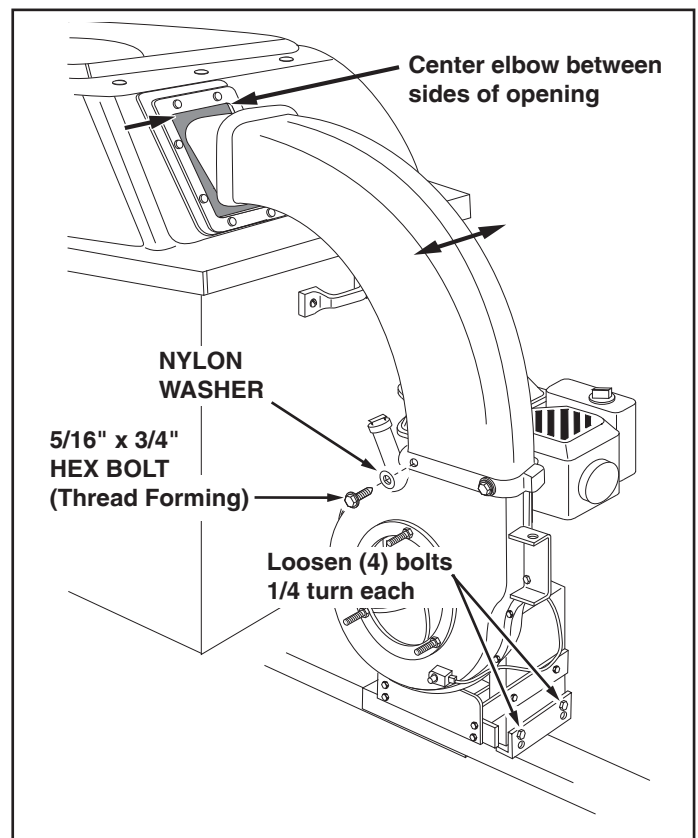

FIGURE 17

32. Assemble the hose adapter (nozzle) to the front of the impeller housing and secure with the three knobs. Make sure that the switch actuator bracket contacts the switch on the housing. See figure 18.

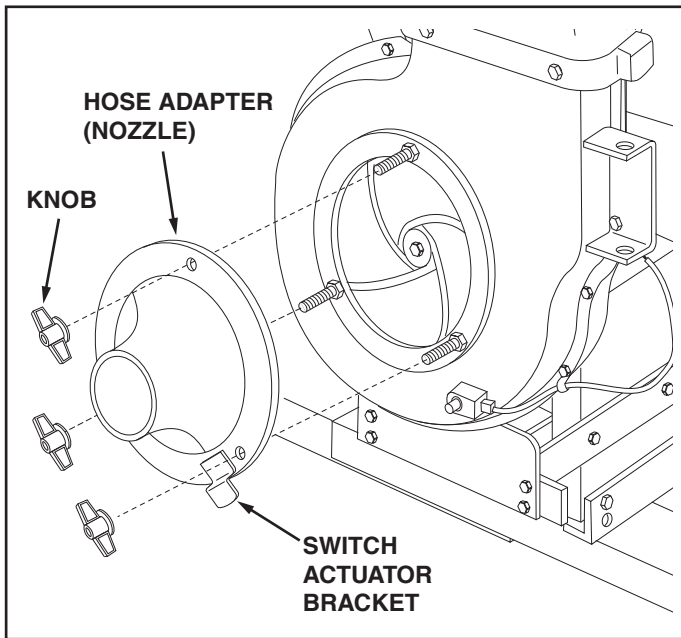

FIGURE 18

33. Place a hose clamp onto end of hose. Push hose onto hose adapter (nozzle). Tighten hose clamp onto hose and hose adapter. **Do not collapse hose adapter when tightening clamp.** See figure 19.

34. The remaining hose clamp will later be used to fasten the other end of the hose to the deck adapter.

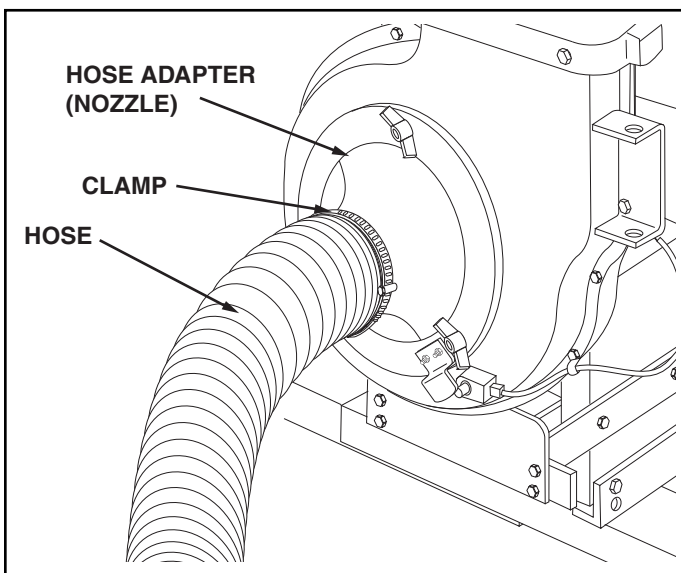

FIGURE 19

35. Place the hose hanger rod assembly into the hose hanger bracket on the impeller housing assembly. See figure 20.

36. Loop the 25" tarp strap under the hose. Fasten the hooks to the hose hanger rod. See figure 20.

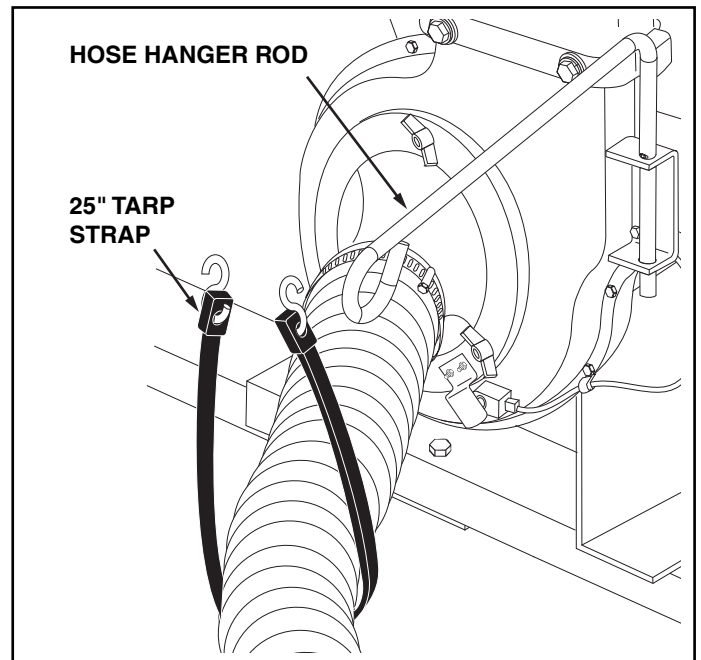

FIGURE 20

37. Assemble the hitch plate to the tractor hitch if:

- a. Your tractor has a square (straight) hitch frame, to help prevent binding.

- b. Your tractor has a lightweight hitch frame that needs reinforcing for towing the Mow-N-Vac.

Use a 1/2" x 1-1/4" hex bolt, a 7/16" flat washer and a 1/2" Nylock hex nut. See figure 21.

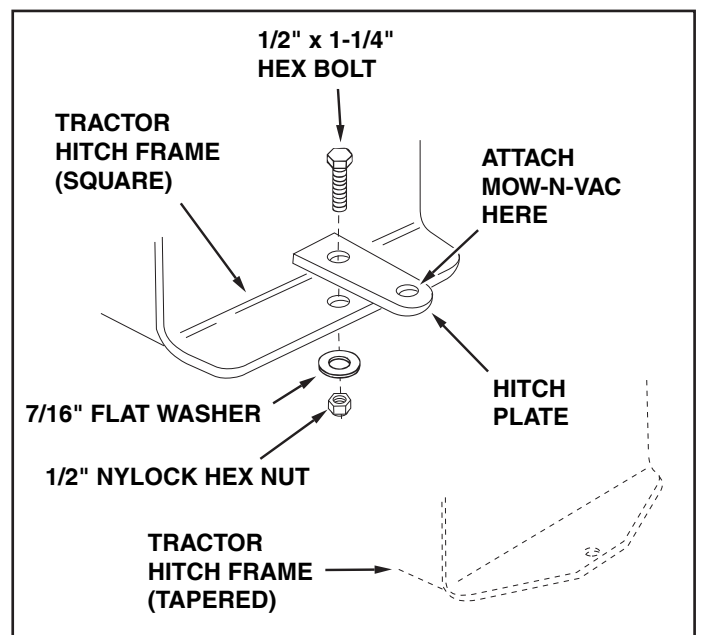

FIGURE 21



**BEFORE PROCEEDING**, look in the fold-out sheets to find the template for your mower deck. If written instructions are printed on the template, follow those instructions instead of the instructions in this manual.

## ASSEMBLING THE DECK ADAPTER (#62468) TO THE MOWER DECK

Need more help cutting out and assembling the deck adapter? Scan the QR Code below with free ShowUHow Mobile App available at iTunes Store or Android Market and refer to Segment 6.

Or visit [www.agri-fab.com](http://www.agri-fab.com) for product assembly instructions.



### Contents of Hardware Pack for Deck Adapter:

REF.	PART NO.	QTY.	DESCRIPTION
A	43840	2	Hex Bolt, 5/16" x 1-1/4"
B	43661	4	Hex Bolt, 1/4" x 1"
C	43080	2	Carriage Bolt, 5/16" x 3/4"
D	47810	3	Hex Nylock Nut, 5/16"
E	47189	5	Hex Nylock Nut, 1/4"
F	43088	9	Flat Steel Washer, 1/4" Std.
G	43081	12	Flat Washer, 5/16" Std.
H	1543-69	5	Nylon Washer
I	23825	1	Mounting Strap
J	23826	1	Angle Bracket
K	23827	1	Mounting Bracket

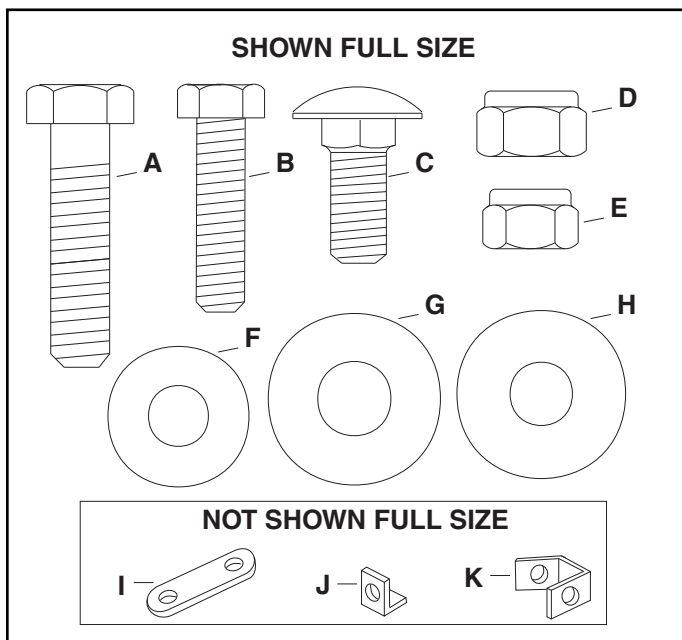

FIGURE 22

**NOTE:** Not all of the hardware will be used for any one particular fit up.

1. Identify and cut out the template for your **brand and size** mower deck. If there is no template included for your deck size, you can make your own template by marking around a piece of cardboard held against the edge of the deck's discharge opening.
2. **FOLLOW THE INSTRUCTIONS PRINTED ON THE TEMPLATE.** If there are no instructions, use the following instructions as a general guide.
3. Tape the template to the face of the adapter, about 1/2" from front and 1/4" down from top for deeper decks. For shallow decks, position template low enough that adapter will not extend below bottom of deck. Mark outline of template on face of adapter using white crayon, nail or scribe. Drill a starting hole inside the outline, then use a saber saw or key hole saw to cut out the opening. See figure 23.

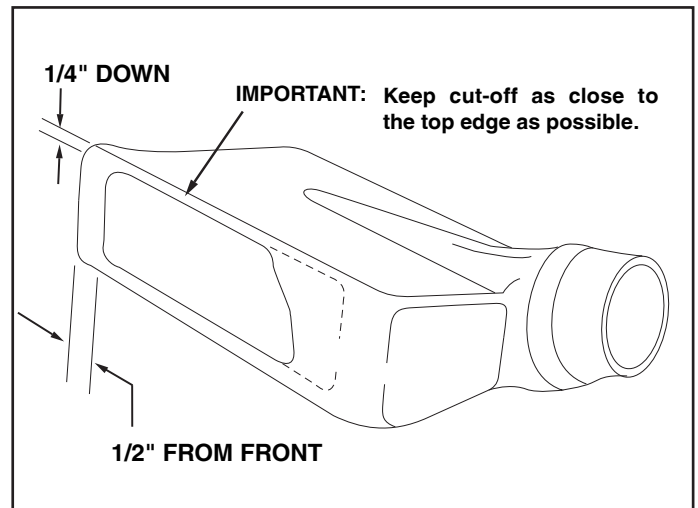

FIGURE 23

### PERFORM THIS STEP ONLY IF NECESSARY.

4. Remove the mower discharge deflector from your mower deck if necessary to attach deck adapter. Save the deflector and hardware for remounting deflector.



**CAUTION:** Mower deflector must be replaced when Vac System deck adapter is removed. Do Not operate mower unless adapter or deflector is in place and properly mounted.

- Position the adapter over the deck opening, and check for fit of cutout as shown in figure 24. Trim cutout, if necessary, to allow tilting of adapter, keeping the fit as close as possible for best vacuum suction.

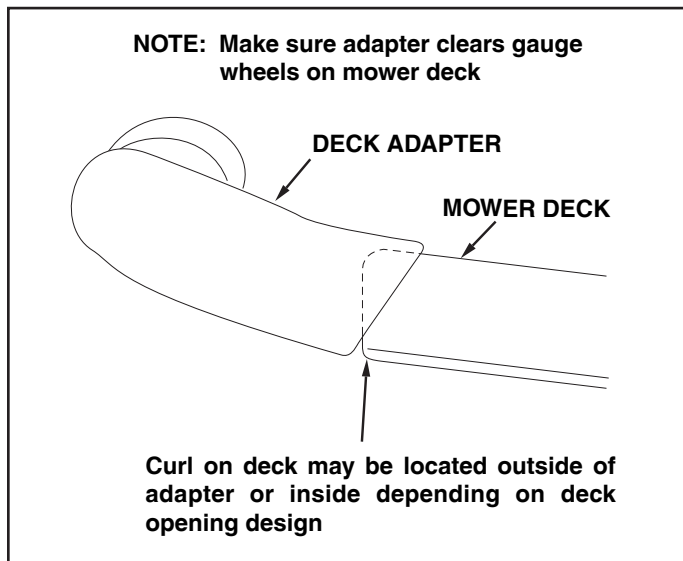

FIGURE 24

- Holding the adapter bracket and the deck adapter together, position the deck adapter on the mower deck. Keeping the edge of deck adapter as close as possible to the offset in the adapter bracket, see if the slot in the adapter bracket can be aligned with one or two of the deflector holes in your mower deck's discharge opening. If the bracket can not be located correctly using existing holes, it will be necessary to drill one or two 5/16" diameter holes in the deck. See figure 25.

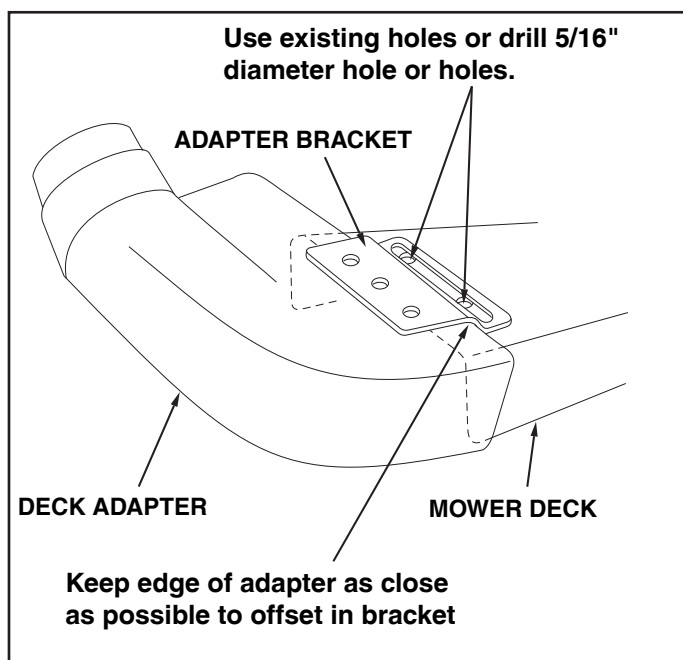

FIGURE 25

- Assemble the adapter bracket to the deck using two 5/16" x 1" hex bolts, 5/16" flat washers and 5/16" Nylock hex nuts. See figure 26.

**NOTE:** It may be necessary to use extra 5/16" flat washers to shim under the bracket next to the deck surface. Ten extra washers have been furnished as shims. See figure 26.

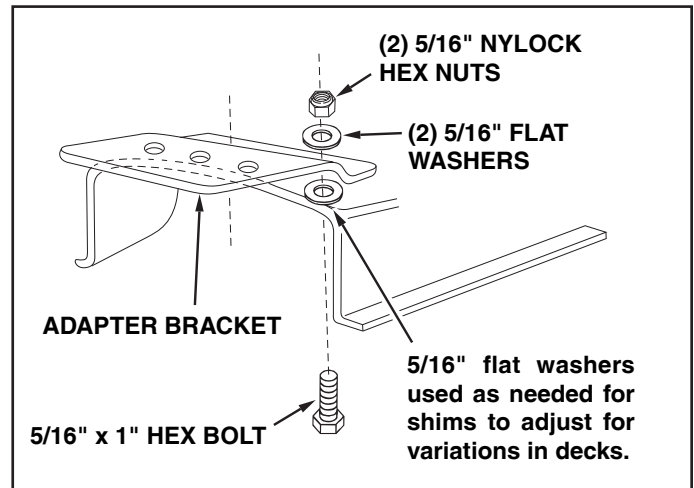

FIGURE 26

- With deck adapter positioned correctly over the discharge opening, use the adapter bracket as a template and drill three 9/32" diameter holes in the top of the deck adapter. See figure 27.
- Bolt deck adapter to bracket using three 1/4" x 1" bolts, nylon washers, 1/4" flat washers and 1/4" Nylock hex nuts. Nylon washers should be against the inside of the deck adapter. See figure 27.

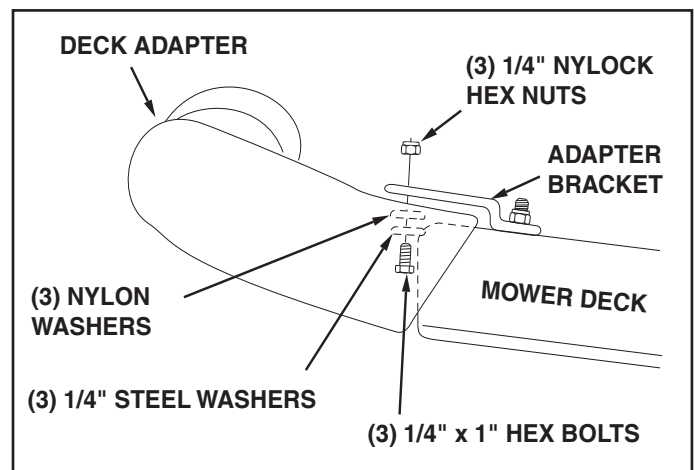

FIGURE 27

- Assemble end of hose and a hose clamp over the round opening of deck adapter and tighten clamp. **GO DIRECTLY TO THE OPERATION INSTRUCTIONS ON PAGE 15.**

# OPERATION

## BEFORE STARTING

1. Your Mow-N-Vac engine is shipped without oil or gasoline. Service the Mow-N-Vac engine with oil and gas as instructed in the separate engine manual.
2. Inspect the Mow-N-Vac to make sure all covers (rear door, vinyl boot, elbow, hose adapter, hose and deck adapter) are properly attached.
3. Check tires for proper inflation (12 - 14 lbs).



**WARNING:** Never fill fuel tank indoors, or with the engine running, or while the engine is hot. Do not smoke while filling tank.

## HOW TO STOP YOUR MOW-N-VAC

1. To stop engine, move the throttle control lever to the OFF position.
2. Disconnect spark plug wire from plug to prevent accidental starting while equipment is unattended or is being worked on.



**CAUTION:** The muffler and adjacent areas are **hot!**

## HOW TO START YOUR MOW-N-VAC



**WARNING:** Never start or run the engine without all covers being properly attached to the blower housing and cart.

1. Check oil and gas in Mow-N-Vac engine.
2. Attach spark plug wire to spark plug.
3. Move choke lever on engine to CHOKE position. (A warm engine may not require choking.)
4. Move throttle control lever on engine to FAST position.
5. Grasp starter handle and pull rope out slowly until engine reaches start of compression cycle (rope will pull slightly harder at this point). Let the rope rewind slowly.
6. Pull rope with a rapid, continuous, full arm stroke. Keep a firm grip on starter handle. Let rope rewind slowly. Do not let starter handle snap back against starter.
7. Repeat instructions in two preceding paragraphs until engine fires. When engine starts, move choke control gradually to RUN position.

## HOW TO USE YOUR MOW-N-VAC



**CAUTION:** Vehicle braking and stability may be affected with the addition of an accessory or an attachment. Be aware of changing conditions on slopes.

1. Inspect the Mow-N-Vac to make sure all covers (rear door, vinyl boot, elbow, hose adapter (nozzle), hose and deck adapter) are properly attached.
2. Check tires for proper inflation (12 - 14 lbs).
3. Check oil and gas in Mow-N-Vac engine.
4. Begin operation at low speed, adjusting forward speed to match grass height and/or moisture condition to prevent clogging.
5. Do not attempt to vacuum up any material other than vegetation found in a normal yard, such as light branches, leaves, twigs, etc.



**WARNING:** Should your Mow-N-Vac become clogged, shut off tractor and Mow-N-Vac engines. Before attempting to unclog, remove wire from spark plug to prevent accidental starting.

6. To empty cart, shut off tractor engine and set brake.
7. Shut off Mow-N-Vac engine.
8. Remove rear door from cart.
9. Release the latch holding cart down to the tongue by pulling up on the latch lever. See figure 28.



**CAUTION:** To avoid possible injury, be sure that no one is near the cart before releasing the latch.

10. Using a rake or suitable tool, pull the grass clippings and/or leaves out of cart.
11. After cart is emptied, secure cart to tongue with latch and reattach the rear door and vinyl boot.

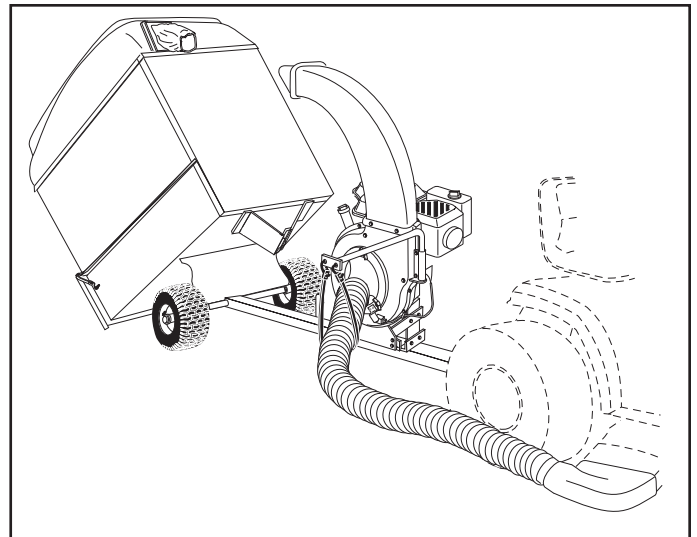

FIGURE 28

# MAINTENANCE

## CUSTOMER RESPONSIBILITIES

- Read and follow the maintenance schedule and the maintenance procedures listed in this section.

MAINTENANCE SCHEDULE Fill in dates as you complete regular service.	Service Dates											
	Before each Use	After each Use	Every season	Before storage								
Check for loose fasteners	X											
Check soft vinyl boot	X											
Check tire pressure	X											
Check engine oil level	X											
Lubricate			X									
Clean		X		X								
Maintain engine per instructions below and in engine manual.												

## BEFORE EACH USE

### CHECK FOR LOOSE FASTENERS

1. Make a thorough visual check of the Mow-N- Vac for any bolts and nuts which may have loosened. Retighten any loose bolts and nuts.

### CHECK VINYL BOOT

2. Check the soft vinyl boot (on front of hard top) for wear. Replace if worn or damaged.

### CHECK TIRE PRESSURE

3. Check tire pressure regularly. Recommended tire pressure is 12-14 Lbs.

### CHECK ENGINE OIL LEVEL

4. Check oil level before each use. Maintain engine oil as instructed in the separate engine manual.

## LUBRICATION

1. At the beginning of each season, lubricate the latch, latch pivot bolt, and the axle where the hitch tongue pivots, with a light machine oil.
2. At least once a season, grease or oil the wheel bearings. Use automotive wheel bearing type grease or 20 weight oil.



**WARNING:** Always stop engine and disconnect spark plug wire before cleaning, lubricating or before performing any repairs or maintenance.

## ENGINE MAINTENANCE

1. Check **oil level** before each use. Maintain engine oil as instructed in the separate engine manual.
2. Service **air cleaner** every 25 hours under normal conditions. Clean every few hours under extremely dusty conditions. Poor engine performance and flooding usually indicates that the air cleaner should be serviced. To service the air cleaner, refer to the separate engine manual.
3. The **spark plug** should be cleaned and the gap reset once a season. Spark plug replacement is recommended at the start of each season. Check the engine manual for correct plug type and gap specifications.

## CLEANING

1. Make sure the cart, the side and front panels and top are cleaned after each use. Grass clippings and leaves left in the cart will mildew and cause damage if not cleaned out.
2. **Clean the engine** regularly with a cloth or brush. Keep the cooling fins on the engine housing clean to permit proper air circulation which is essential to engine performance and life. Be sure to remove all dirt and debris from muffler area.

## STORAGE

1. Clean the engine and the entire unit thoroughly.
2. Refer to engine manual for correct engine storage instructions.
3. If storing in an unventilated or metal storage shed, coat metal parts with light oil or silicone to prevent rust.
4. Store unit in a clean, dry area.

# TROUBLESHOOTING

PROBLEM	POSSIBLE CAUSE(S)	CORRECTIVE ACTION
Engine fails to start	<ol style="list-style-type: none"> <li>1. Spark plug wire disconnected.</li> <li>2. Safety switch not contacted.</li> <li>3. Fuel tank empty, or stale fuel.</li> <li>4. Fuel shut-off valve closed (if so equipped).</li> <li>5. Faulty spark plug.</li> </ol>	<ol style="list-style-type: none"> <li>1. Connect wire to spark plug.</li> <li>2. Correctly install hose adapter nozzle.</li> <li>3. Fill tank with clean, fresh fuel.</li> <li>4. Open fuel shut-off valve.</li> <li>5. Clean, adjust gap or replace.</li> </ol>
Loss of power; operation erratic.	<ol style="list-style-type: none"> <li>1. Spark plug wire loose</li> <li>2. Unit running on CHOKE.</li> <li>3. Blocked fuel line or stale fuel.</li> <li>4. Water or dirt in fuel system.</li> <li>5. Carburetor out of adjustment.</li> <li>6. Dirty air cleaner.</li> </ol>	<ol style="list-style-type: none"> <li>1. Connect and tighten spark plug wire.</li> <li>2. Move choke lever to OFF position.</li> <li>3. Clean fuel line; fill tank with clean fresh gasoline.</li> <li>4. Disconnect fuel line at carburetor to drain fuel tank. Refill with fresh fuel.</li> <li>5. Adjust carburetor.*</li> <li>6. Service air cleaner.*</li> </ol>
Engine overheats	<ol style="list-style-type: none"> <li>1. Carburetor not adjusted properly.</li> <li>2. Engine oil level low.</li> </ol>	<ol style="list-style-type: none"> <li>1. Adjust carburetor.*</li> <li>2. Fill crankcase with proper oil.</li> </ol>
Too much vibration	Loose parts or damaged impeller.	Stop engine immediately and disconnect spark plug wire. Tighten all bolts and nuts. Make all necessary repairs. If vibration continues, have unit serviced by an authorized service dealer.
Unit does not discharge	<ol style="list-style-type: none"> <li>1. Discharge chute (elbow) clogged.</li> <li>2. Foreign object lodged in impeller.</li> <li>3. Mow-N-Vac cart is full.</li> </ol>	<ol style="list-style-type: none"> <li>1. Stop engine immediately and disconnect spark plug wire. Clean inside of housing and discharge chute (elbow).</li> <li>2. Stop engine immediately and disconnect spark plug wire. Remove lodged object.</li> <li>3. Empty cart.</li> </ol>

\*Refer to the engine manual packed with your unit.

**NOTE:** For repairs beyond the minor adjustments listed above, please contact your nearest authorized service dealer.

## NOTES

# PARTS

## REPAIR PARTS FOR MOW-N-VAC CART BODY MODELS 551889, 190-217F-100

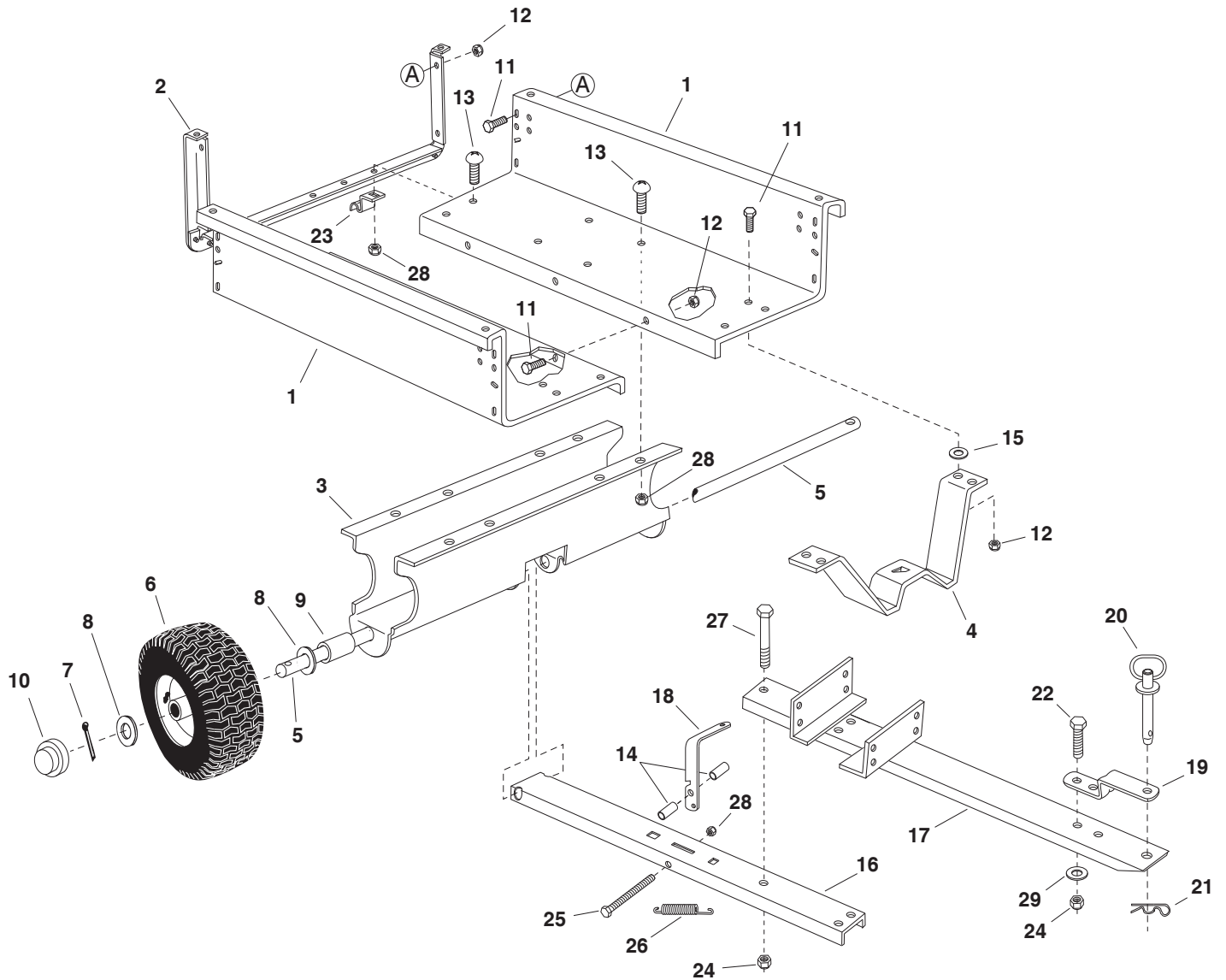

REF.	PART NO.	QTY.	DESCRIPTION	REF.	PART NO.	QTY.	DESCRIPTION
1	23985	2	Cart Body	16	63917	1	Tongue Weldment Ass'y. (Rear)
2	62458	1	Tailgate Reinforcement Bracket	17	63155	1	Tongue Weldment Ass'y. (Front)
3	23507	1	Wheel Support	18	24614	1	Latch Lock Lever
4	24497	1	Latch Stand Bracket	19	23475	1	Hitch Bracket
5	24897	1	Axle, Wheel 1" Dia.	20	43884	1	Hitch Pin
6	42159	2	Wheel w/Tire, 15 x 6.00	21	43343	1	Pin, Hair Cotter 1/8"
7	43093	2	Cotter Pin, 1/8" Dia. x 1-1/2"	22	43087	2	Hex Bolt, 3/8-16 x 1-1/4"
8	43601	4	Washer, Flat 1"	23	23838	2	Door Support
9	44678	2	Spacer Tube, 1-1/4" x 2" Lg.	24	HA21362	5	Nut, Hex Nylock 3/8-16
10	43014	2	Hub Cap	25	47407	1	Hex Bolt, 5/16-18 x 3-3/4"
11	43866	9	Hex Bolt, 1/4-20 x 5/8"	26	47408	1	Spring, Extension
12	47189	9	Hex Nut, 1/4-20 Nylock	27	43574	3	Hex Bolt, 3/8-16 x 3"
13	43814	12	Truss Hd. Bolt, 5/16-18 x 3/4"	28	47810	13	Hex Nut, 5/16-18 Nylock
14	41076	2	Spacer	29	43081	2	Washer, 3/8"
15	43088	2	Washer, Flat 1/4"				

# REPAIR PARTS FOR MOW-N-VAC MODELS 551889, 190-217F-100

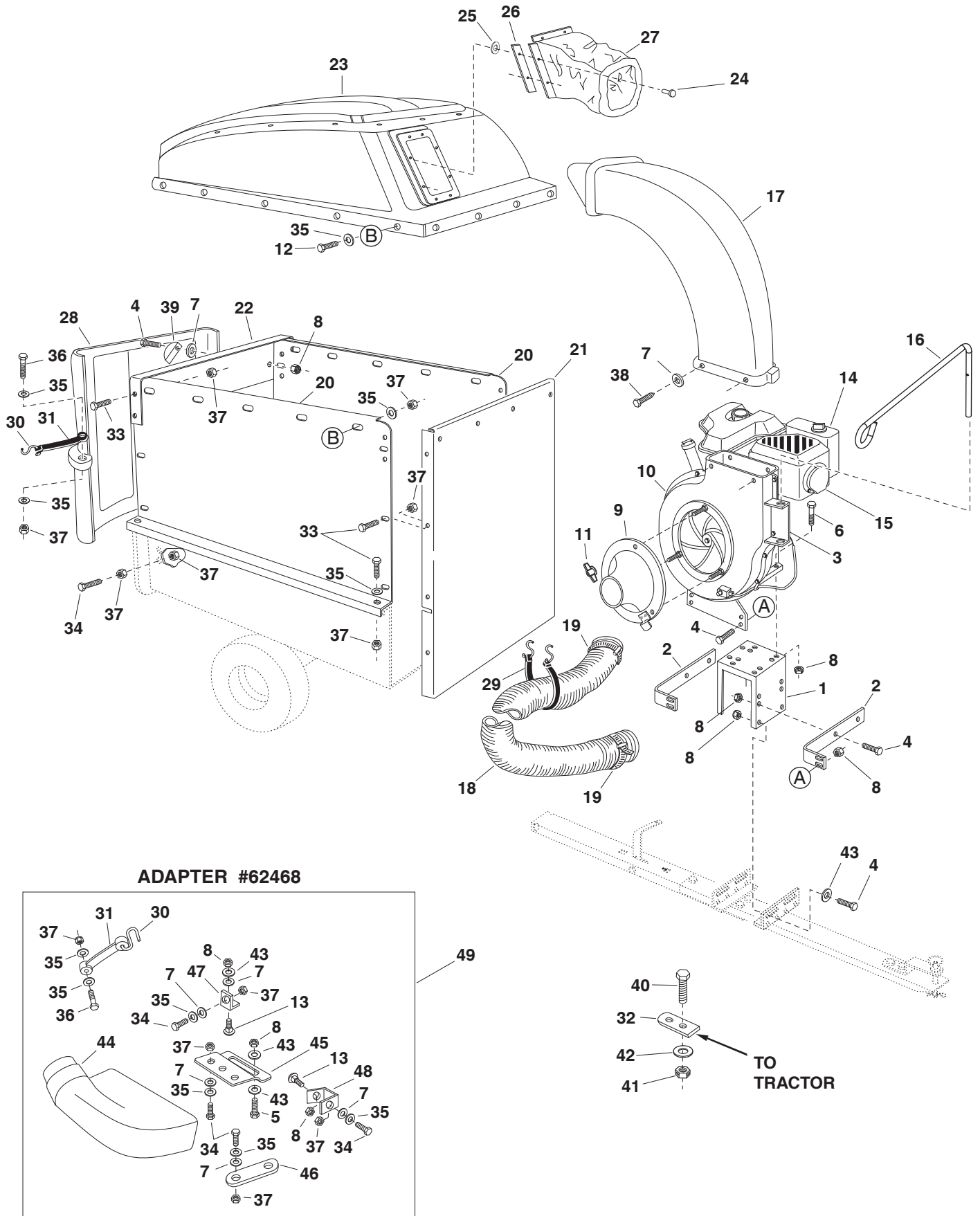

**REPAIR PARTS FOR MOW-N-VAC  
MODELS 551889, 190-217F-100**

REF	PART NO.	QTY.	DESCRIPTION	REF	PART NO.	QTY.	DESCRIPTION
1	24080	1	Engine Base	25	43910	21	Washer, Flat 3/16"
2	24078	2	Brace, Housing	26	24798	4	Boot Mounting Strap
3	63226	1	Hose Hanger Bracket Ass'y. (Ref. item #16 on page 22.)	27	48133	1	Hard top Boot
4	43182	14	Bolt, Hex 5/16-18 x 3/4"	28	44790	1	Poly Rear Door
5	43840	2	Bolt, Hex 5/16-18 x 1-1/4"	29	43790	1	Strap, Tarp 25"
6	43085	4	Bolt, Hex 5/16-18 x 1-1/2"	30	44849	4	"S" Hook, #32
7	1543-69	9	Washer, Nylon 21/64"	31	44850	4	Strap, Tarp (Less Hooks)
8	47810	18	Nut, Hex Nylock 5/16-18	32	23540	1	Hitch Plate
9	43791	1	Hose Adapter	33	43866	20	Bolt, Hex 1/4-20 x 5/8"
10		1	Impeller Housing Assembly (See page 22)	34	43661	6	Bolt, Hex 1/4-20 x 1"
11	712-0421	3	Knob (See Item #8, Page 22)	35	43088	45	Washer, 1/4" STD
12	43012	13	Bolt, Hex 1/4-20 x 3/4"	36	1509-90	5	Bolt, Hex 1/4-20 x 1-1/4"
13	43080	2	Bolt, Carr. 5/16" x 3/4"	37	47189	43	Nut, Hex Nylock 1/4-20
14	42462	1	Engine (50 State)	38	47630	4	Screw, Self Tap 5/16-18 x 3/4"
15	222261	1	Deflector, Muffler	39	23789	2	Door Latch
16	49974	1	Hose Hanger Rod	40	43351	1	Bolt, Hex 1/2-13 x 1-1/4"
17	46420	1	Elbow	41	712-3083	1	Nut, Hex Nylock 1/2-13
18	41882	1	Hose (6" x 84")	42	43352	1	Washer, Flat 7/16"
19	43793	2	Hose Clamp 6"	43	43081	16	Washer, 5/16" STD
20	24678	2	Side Panel Cart Extension	44	43830	1	Adapter, Deck
21	24679	1	Front Panel Cart Extension	45	23560	1	Bracket, Deck Adapter
22	23836	1	Cross Brace	46	23825	1	Mounting Strap
23	64244	1	Hard Top Assembly (Includes 24,25,26,27)	47	23826	1	Angle Bracket
24	43882	21	Rivet, 3/16"	48	23827	1	Mounting Bracket
				49	62468	1	Deck Adapter Kit (Includes parts in box shown on page 20)
					42490	1	Owner's Manual

# REPAIR PARTS FOR MOW-N-VAC IMPELLER HOUSING ASSEMBLY MODELS 501887, 501888, 551887, 551888, 190-217D-100 & 190-217E-100

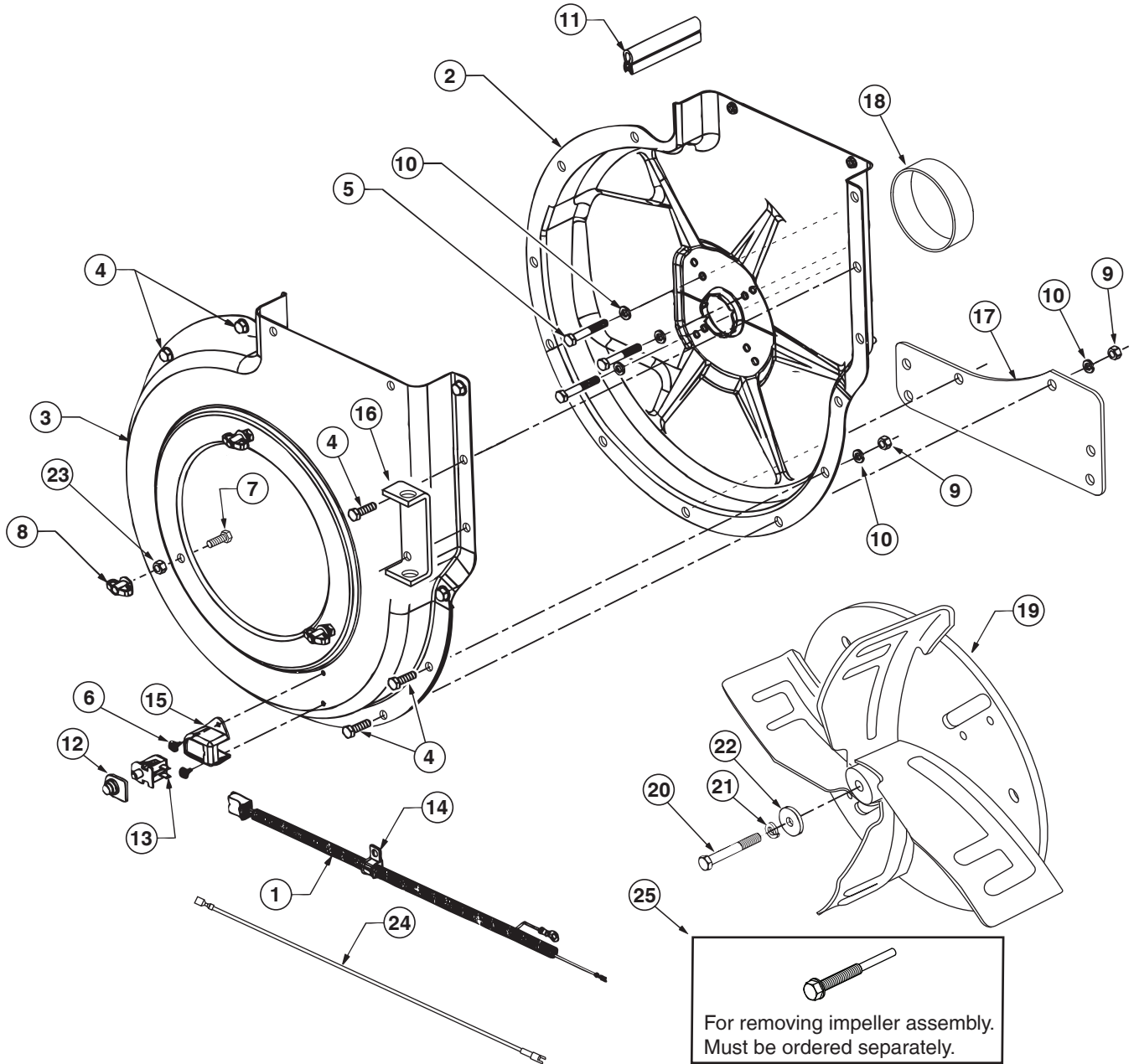



REF.	PART NO.	QTY.	DESCRIPTION	REF.	PART NO.	QTY.	DESCRIPTION
1	629-0241A	1	Harness, Wire	14	726-0272	1	Clamp
2	24634	1	Housing Ass'y. Inner	15	731-1613	1	Cover, Switch
3	24633	1	Housing Ass'y. Outer	16	24958	1	Hose Hanger Bracket
4	43182	12	Bolt, Hex 5/16-18 x 3/4"	17	24606	1	Spacer, Housing
5	710-0772	3	Bolt, Hex 5/16-24 x 2"	18	719-0330B	1	Adapter, Mounting
6	710-1268	2	Screw, Self Tap #10-16 x 3/8"	19	66886	1	Impeller Assembly
7	43063	3	Bolt, Hex 5/16-18 x 1"	20	710-1273	1	Bolt, Hex 3/8-24 x 2-3/4"
8	712-0421	3	Knob	21	43003	1	Lockwasher, 3/8"
9	48848	12	Nut, Nylock Jam 5/16-18	22	736-0247	1	Flat Washer, 13/32" x 1-1/4"
10	43086	3	Lock Washer, 5/16"	23	46584	3	Nut, Whizlock 5/16-18
11	723-0438	1	Seal, Rubber	24	629-0923	1	Harness Adapter
12	725-1700	1	Cover, Switch	25	42294	1	Impeller Service Tool
13	725-3166	1	Snap Mount Switch				

# SLOPE GUIDE

(Keep this sheet in a safe place for future reference.)

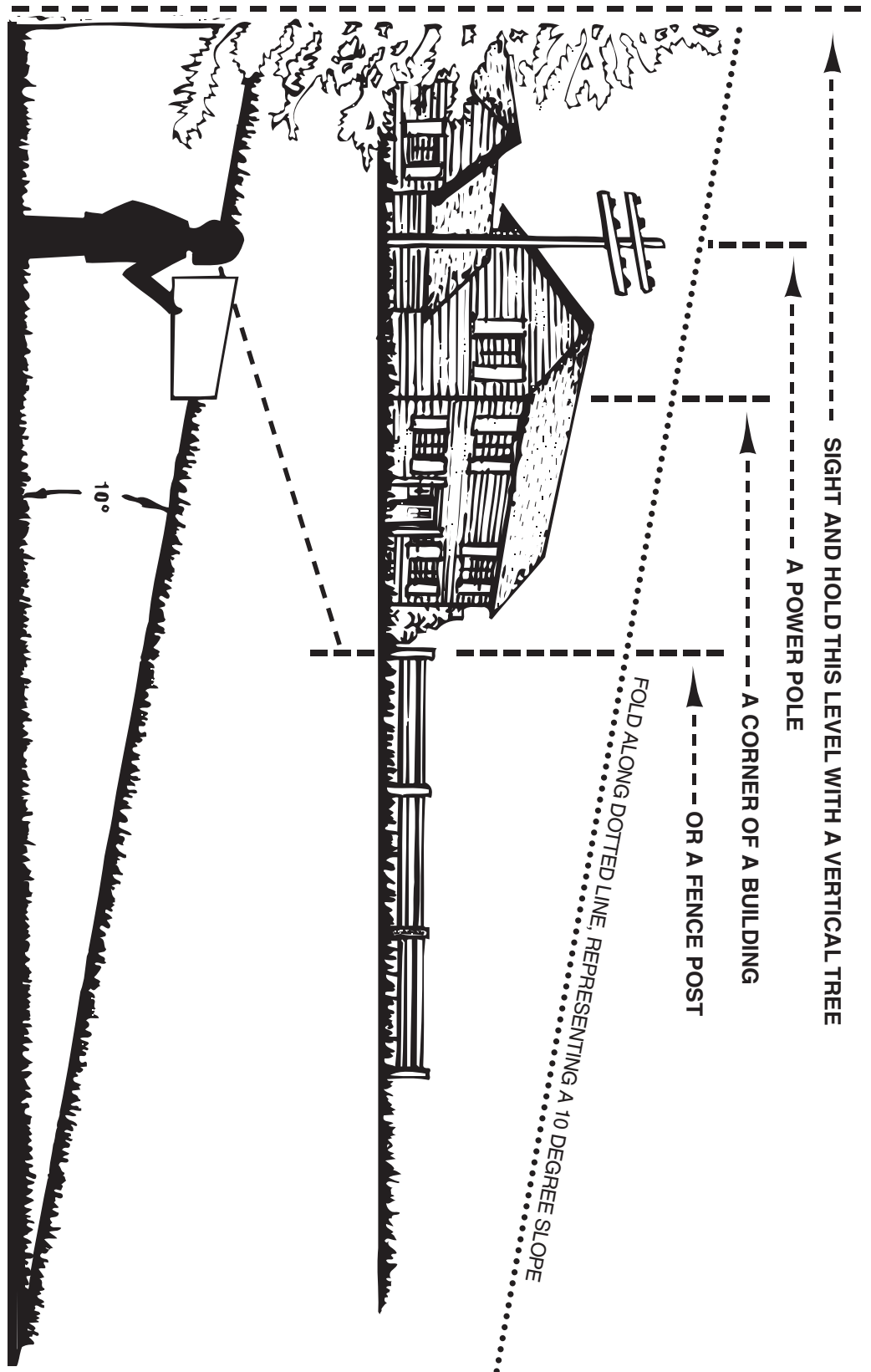
Use this guide to determine if a slope is safe for the operation of your tractor and Mow-N-Vac. Refer also to the instructions in your vehicle owners manual.



 **CAUTION:** Do not operate your tractor and Mow-N-Vac on a slope in excess of 10 degrees. Be sure of your tractor's towing and braking capabilities before operating on a slope. Avoid any sudden turns or maneuvers while on a slope.

***SpeedEPart*** *the fastest way to purchase parts* [www.speedepart.com](http://www.speedepart.com)

**REPAIR PARTS**

Agri-Fab, Inc.  
303 West Raymond  
Sullivan, IL. 61951  
217-728-8388  
[www.agri-fab.com](http://www.agri-fab.com)

This document (or manual) is protected under the U.S. Copyright Laws and the copyright laws of foreign countries, pursuant to the Universal Copyright Convention and the Berne convention. No part of this document may be reproduced or transmitted in any form or by any means, electronic or mechanical, including photocopying or recording, or by any information storage or retrieval system, without the express written permission of Agri-Fab, Inc. Unauthorized uses and/or reproductions of this manual will subject such unauthorized user to civil and criminal penalties as provided by the United States Copyright Laws.