

Ava 30 Cabinet Installation Instruction

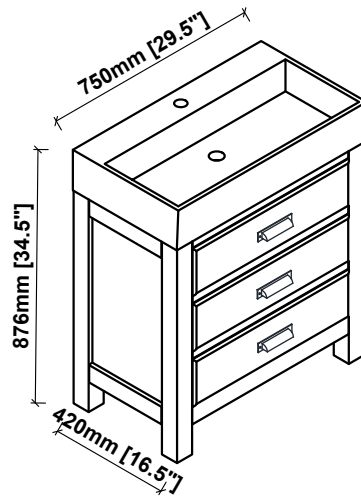

DIMENSIONS

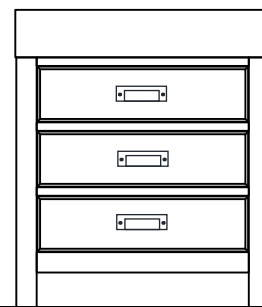
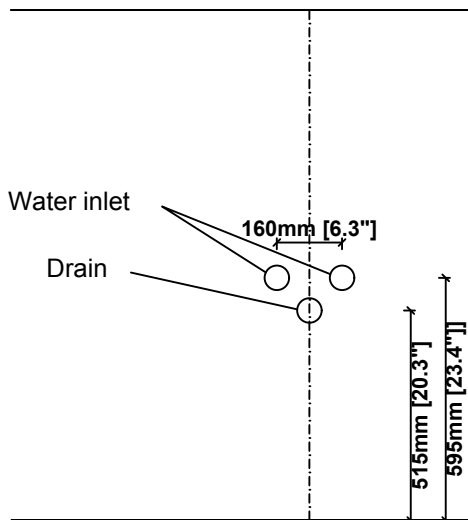
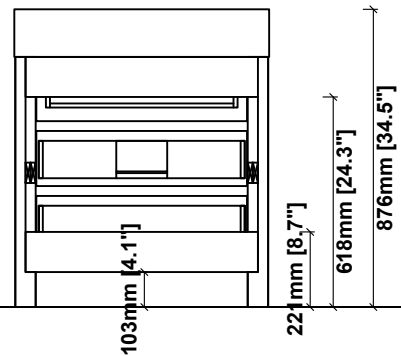
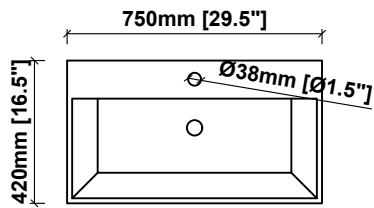

WARNING!

In the hole on the wall, please be sure to be careful to avoid the internal cables pipelines.

MATERIALS & TOOLS

safety glasses, pencil, level, Tape measure, stud finder Assorted screwdrivers, Assorted Wrenches, Drill, Screw gun, Caulking gun, Hammer. Screws, Nachors/Molly screws.

- ▶ If the floor is uneven, the adjustable feet levelers can be rotated to raise the vanity to the desired height.

