

## Tandem Combination Type Arc-Fault Circuit Interrupters (CAFCI)

Pigtail and Plug-On Neutral

Pigtail

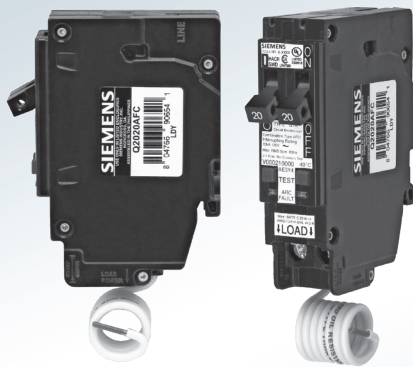

Plug-On Neutral

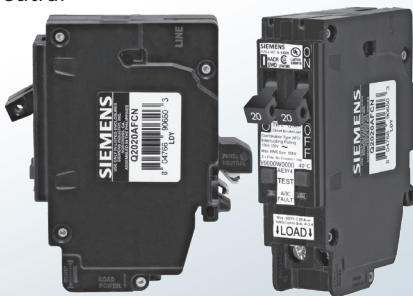

Siemens Tandem AFCI Breakers are the perfect solution to wiring made easier. The design allows for more circuits in a smaller loadcenter. Installed indicator flags disappear when the load wires are inserted correctly.

Siemens CAFCI Plug-On breakers now have a single load lug(s) only. Wiring made easier with the neutral lug removed. These breakers can be installed in the same manner as the thermal magnetic breakers. This allows the installer to land ground and neutral conductors in the load center before installing the breaker and load conductor.

Tandem AFCI breakers without the rejection feature can be installed in any panel that lists that breaker type or where a substitution letter exists for that breaker type. The schematic, located on the wiring diagram, will indicate the positions where these breakers can be placed by showing two circuits per space. The total circuits listed for panel should not be exceeded.

### Features

- One breaker feeds two circuits to save on space and time
- Installed indicator flags disappear when the load wires are inserted correctly
- Load Lug(s) only
- Available in pigtail and Plug-On neutral types
- Trusted Plug-On Neutral connection
- LED indicators for troubleshooting
- Insta-wire connectors

### Technical Data

- 10,000 AIC
- 120V
- UL Listed
- HACR and SWD rated

Catalog Number	Ampere Rating	Interrupting Rating	UL Type	Connection Type
Q1515AFC	15/15	10kA	QTA	Pigtail
Q2020AFC	20/20	10kA	QTA	Pigtail
Q1515AFCN	15/15	10kA	QTAN	Plug-On Neutral
Q2020AFCN	20/20	10kA	QTAN	Plug-On Neutral

# Wiring Diagrams

## Pigtail

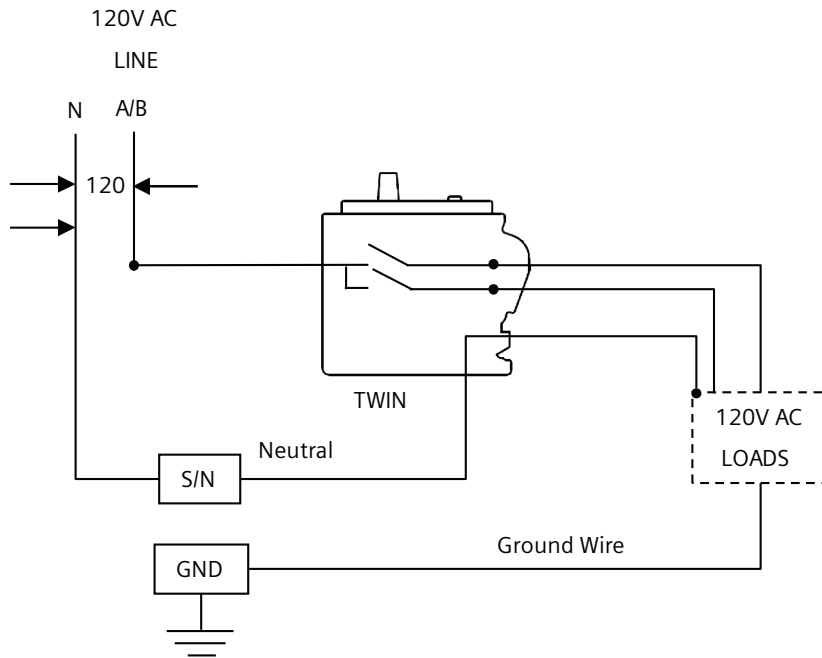

## Plug-On Neutral

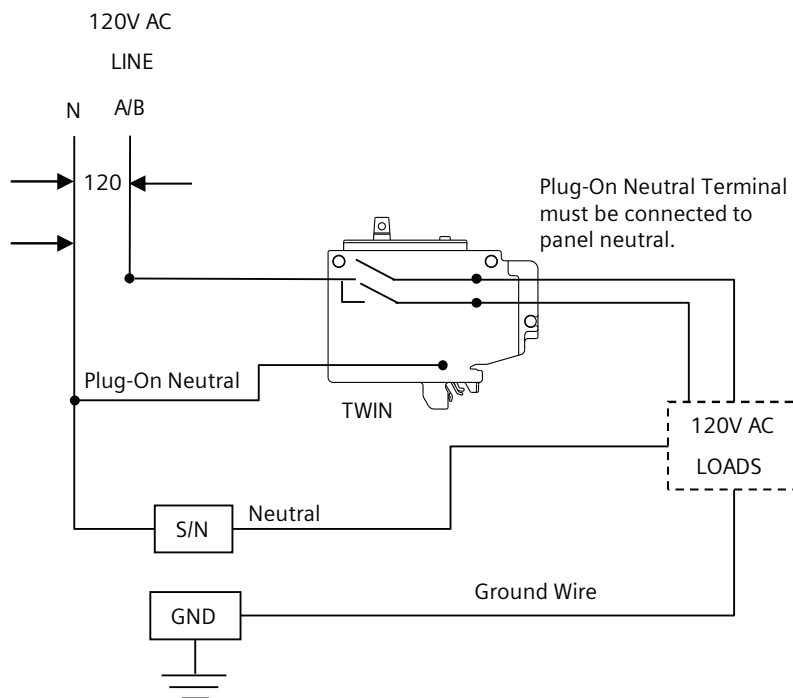

# Dimension Diagrams

## Pigtail

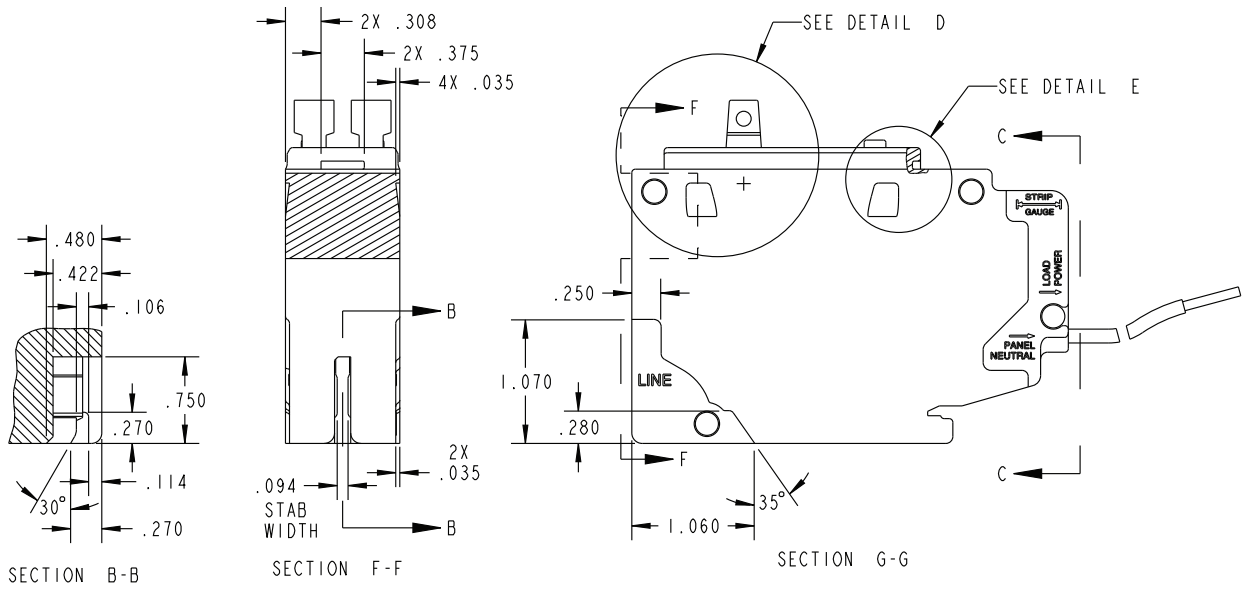

## Plug-On Neutral

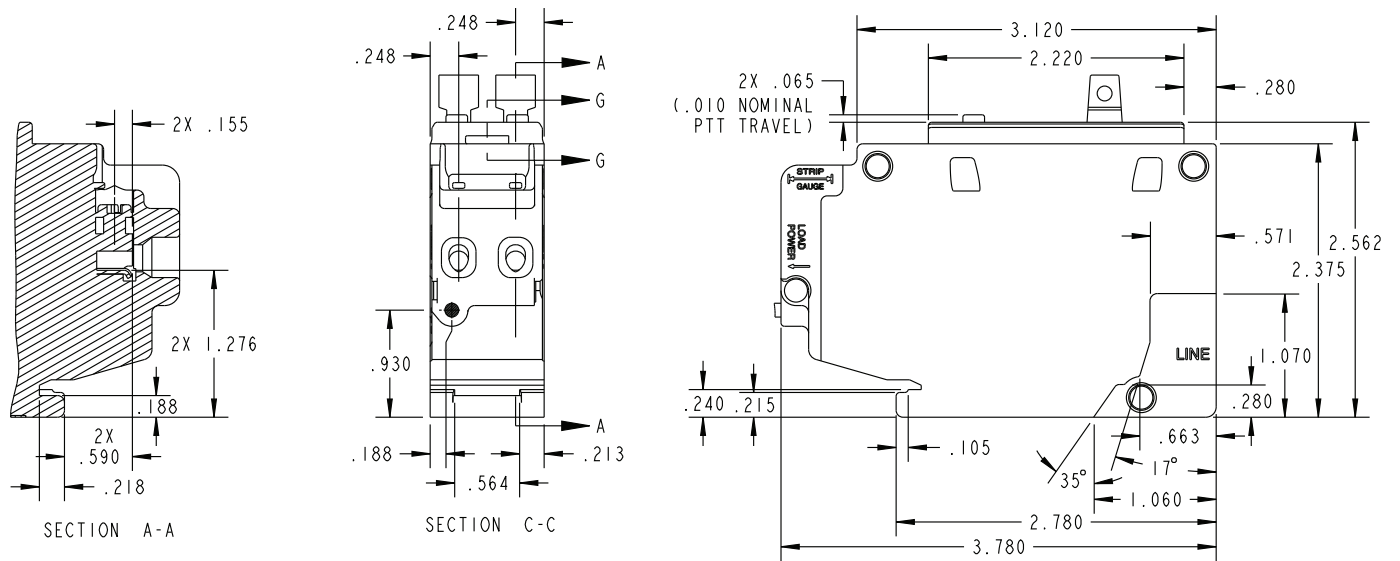

# Time Current Characteristic Curve – 15A

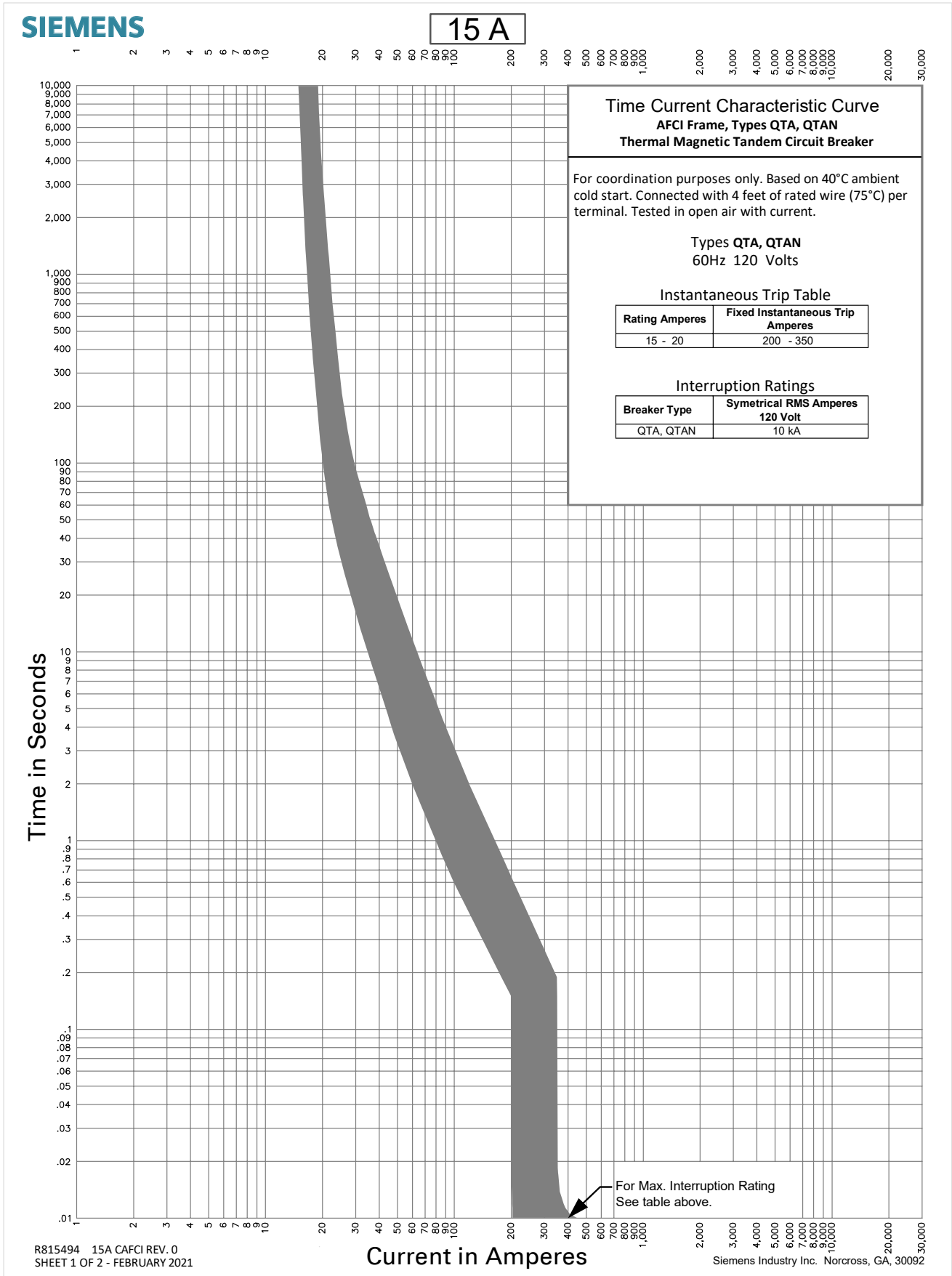

# Time Current Characteristic Curve – 20A

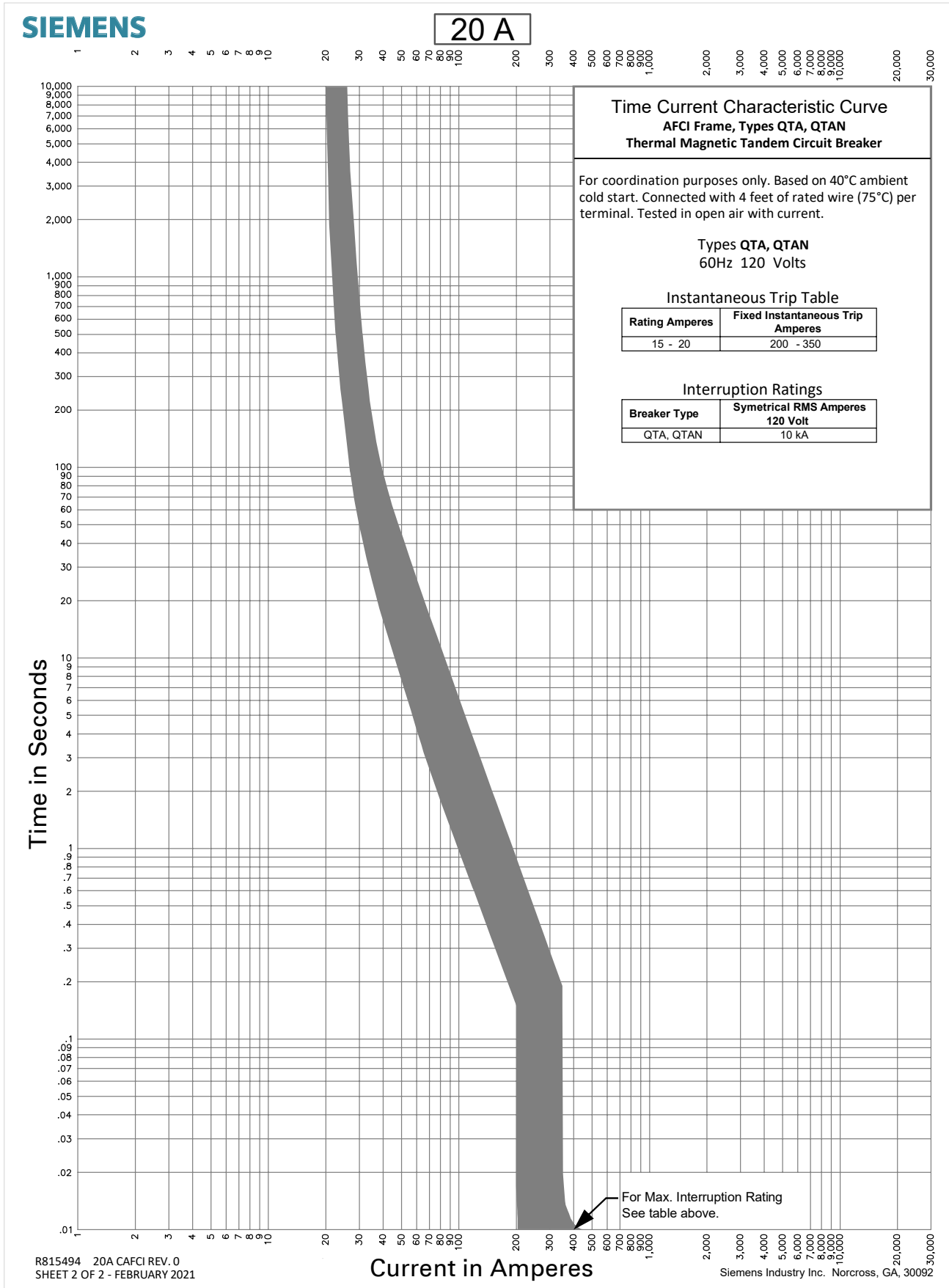





**Published by  
Siemens 2021**

Siemens Industry, Inc.  
3617 Parkway Ln  
Peachtree Corners, GA 30092

Siemens Technical Support: 1-800-333-7421  
info.us@siemens.com

Order No. RPDS-CAFCI-0421  
Printed in USA  
All Rights Reserved  
© 2021, Siemens Industry, Inc.  
usa.siemens.com/afci

The technical data presented in this document is based on an actual case or on as-designed parameters, and therefore should not be relied upon for any specific application and does not constitute a performance guarantee for any projects. Actual results are dependent on variable conditions. Accordingly, Siemens does not make representations, warranties, or assurances as to the accuracy, currency or completeness of the content contained herein. If requested, we will provide specific technical data or specifications with respect to any customer's particular applications. Our company is constantly involved in engineering and development. For that reason, we reserve the right to modify, at any time, the technology and product specifications contained herein.