

ASSEMBLY INSTRUCTIONS

TOOLS REQUIRED



Allen Wrench

(Included)



Phillips
Screwdriver

(Not Included)

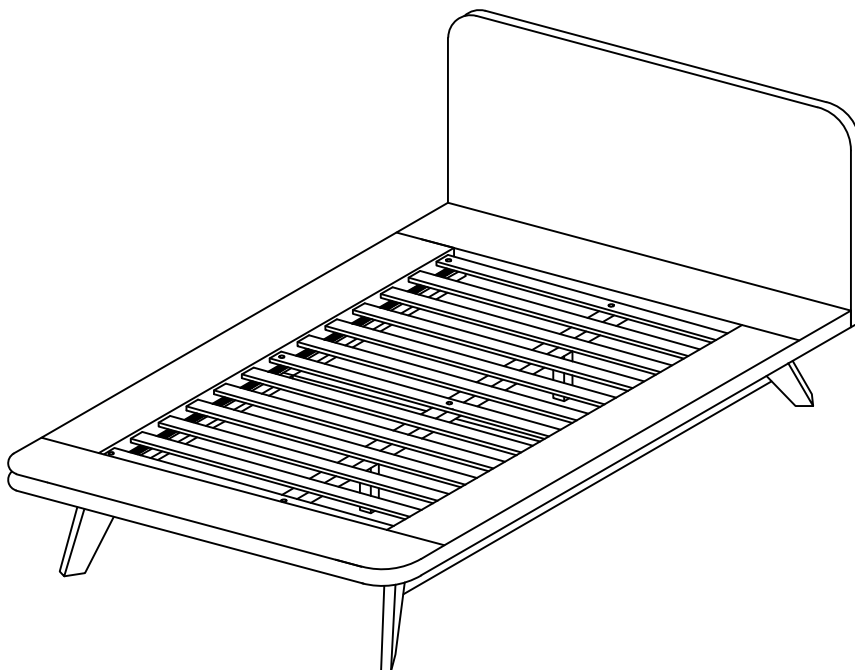

2 - Persons
Recommended

ASSEMBLY RATING



EASY ————— DIFFICULT

The Assembly Rating is a 5-point system showing the level of effort needed to assemble a specific product.



CHECK BEFORE STARTING



Are you missing anything?

Double-check all parts, hardware and accessories listed on Page 6 are accounted for.



Check out our Quick Tips!

We recommend reviewing the pre-assembly handouts. Even experts need a refresher now and then!



Should we send any replacements?

Are there any irregularities or flaws in the parts? We can send replacements!



Prep Time!

Please review the assembly instructions and all diagrams prior to assembling. Set up your workspace by laying the parts and hardware out separately, then begin!

PRE ASSEMBLY INTRODUCTION

We understand building ready-to-assemble furniture can be a challenging experience for some. To help avoid confusion, we have provided some helpful tips that may speed up the process.



Teamwork

ALWAYS have at least two people to help with transporting and assembling the product to avoid potential injury and/or damage.

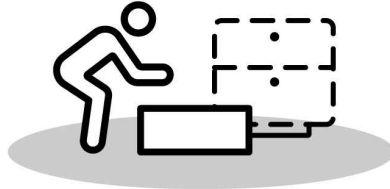

Suitable Location

Assembling near the area of the intended location is highly recommended.



Sufficient Space

Make sure you have enough space to move around during the assembly.



Avoid Scratches

Use cardboard, blankets or a carpeted area while assembling furniture to prevent scratches.



Flat Surface

Make sure the furniture rests on a flat and level surface with each leg evenly touching the floor.

ASSEMBLY AND CARE ADVICE



FAILURE TO FOLLOW THE GUIDELINES BELOW MAY RESULT IN INJURY AND/OR PROPERTY DAMAGE.



Position each part correctly and insert screws or bolts into their respective holes.



Turn clockwise to tighten and only tighten when step is completed or when instructed to do so.



Use the appropriate hand tools or power tools for assembly. Select steps, such as tightening screws and/or bolts, may require hand tools to avoid causing damage during assembly.



Save the instructions and store any supplied tools for later maintenance.



After two weeks, check and tighten any loose hardware and repeat again every six months thereafter.

IT IS THE USER'S RESPONSIBILITY TO MAINTAIN THE FURNITURE. THE HARDWARE MAY LOOSEN OVER TIME AND MAY CAUSE THE FURNITURE TO BE WOBBLY AND UNABLE TO SUPPORT ITS INTENDED WEIGHT CAPACITY. THIS MAY LEAD TO COLLAPSE AND MAY CAUSE SERIOUS INJURY.

FULL BED



- Please keep instructions for future reference.
- Check the quantity and irregularity of parts and hardware before you start.

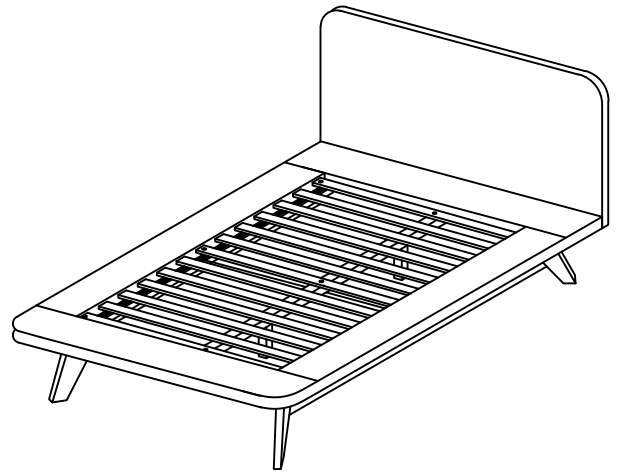

PARTS

#1 1pc

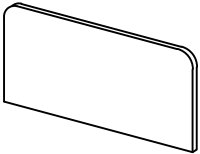

Headboard

#2 1pc



Headboard Panel

#3 1pc

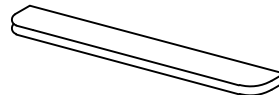

Footboard Panel

#4 2pcs

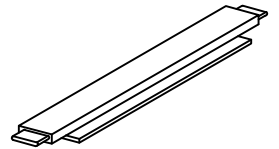

Side Rail Panel

#5 1pc

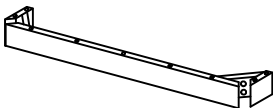

HB Support Wood

#6 1pc

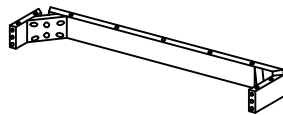

FB Support Wood

#7 2pcs

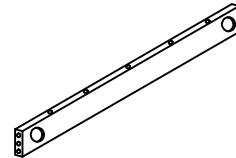

SR Support Wood

#8 1pc

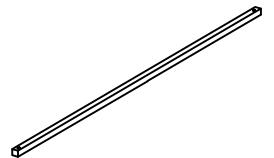

Center Rail

#9 2pcs



Center Support Leg

#10 1pc

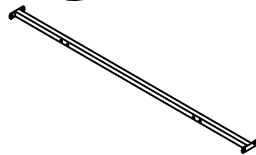

Metal Rail

#11 2pcs



Metal Support Leg

#12 4pcs



Corner Block

#13 4pcs



Bed Leg

#14 1set

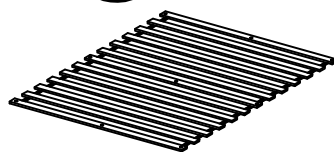

Slat

#15 3pcs

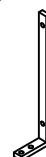

Metal

HARDWARE

#A 4pcs

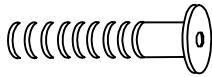

Jcbc Bolt M6 x 20mm

#B 4pcs

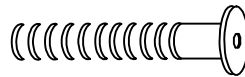

Jcbc Bolt M6 x 40mm (Black)

#C 2pcs

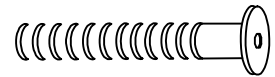

Jcbc Bolt M6 x 50mm

#D 12pcs

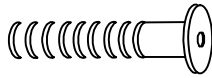

Jcbb Bolt M8 x 30mm

#E 8pcs

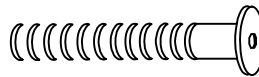

Jcbb Bolt M8 x 50mm

#F 6pcs



M6 Flat Washer

#G 6pcs



M6 Spring Washer

#H 20pcs



M8 Flat Washer

#I 20pcs

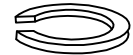

M8 Spring Washer

#J 45pcs

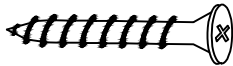

Wood Screw M4 x 32mm

#K 12pcs

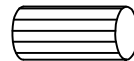

Wood Dowel M8 x 30mm

#L 4pcs

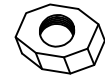

M6 Hex Nut (Black)

#M 4pcs



M8 Hex Nut (Black)

#N 4pcs

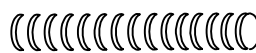

Stud Screw M8 x 95 MS

#O 4pcs



Trub Nut M8

#P 1pc

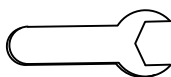

Spanner (10mm)

#Q 1pc

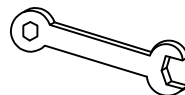

Combination Spanner (13mm)

#R 1pc



M4 Allen Wrench

#S 1pc

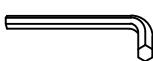

M5 Allen Wrench

#T 2pcs







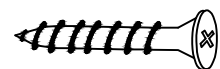





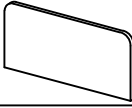
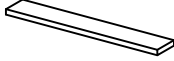
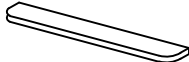

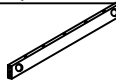
6 Hole Metal Bracket

#U 12pcs

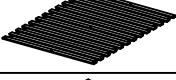

Wood Screw M3.5 x 16mm

POINT 3 CARTONS

Carton	Designation	Part	
	Headboard (1pc)	#1	
	Headboard Panel (1pc)	#2	
	Footboard Panel (1pc)	#3	
	Side Rail Panel (2pcs)	#4	
	SR Support Wood (2pcs)	#7	
	Center Rail (1pc)	#8	
	Center Support Leg (2pcs)	#9	
	Metal Support Leg (2pcs)	#11	
		HB Support Wood (1pc)	#5
FB Support Wood (1pc)		#6	
Metal Rail (1pc)		#10	
Corner Block (4pcs)		#12	
Bed Leg (4pcs)		#13	
Bed Slat (1set)		#14	
Metal (3pcs)		#15	

ASSEMBLY INSTRUCTIONS

1

Part #8 x1pc

Part #9 x2pcs

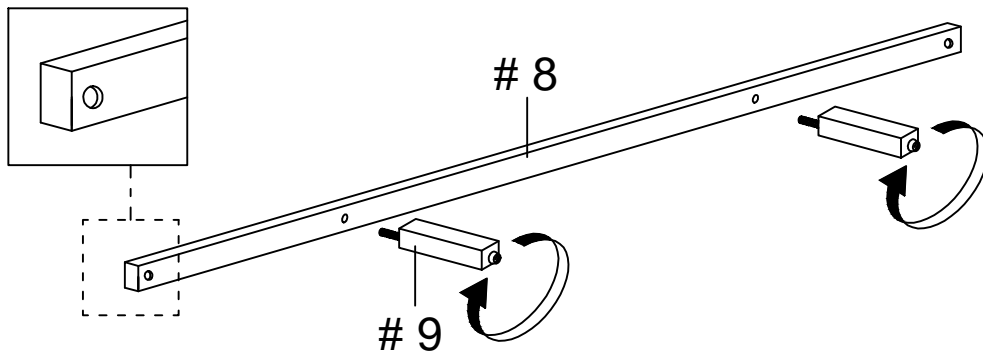

2

Part #10 x1pc

Part #11 x 2pcs

Hardware #B x4pcs

Hardware #L x4pcs

Hardware #P x1pc

Hardware #R x1pc

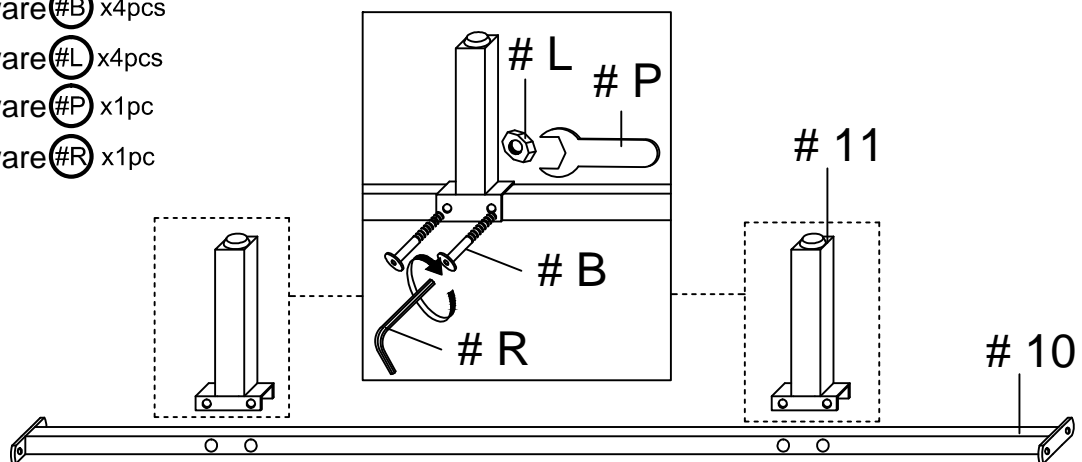

ASSEMBLY INSTRUCTIONS

3

- Part #5 x1pc
- Part #6 x1pc
- Part #7 x2pcs
- Hardware #K x12pcs
- Hardware #N x4pcs

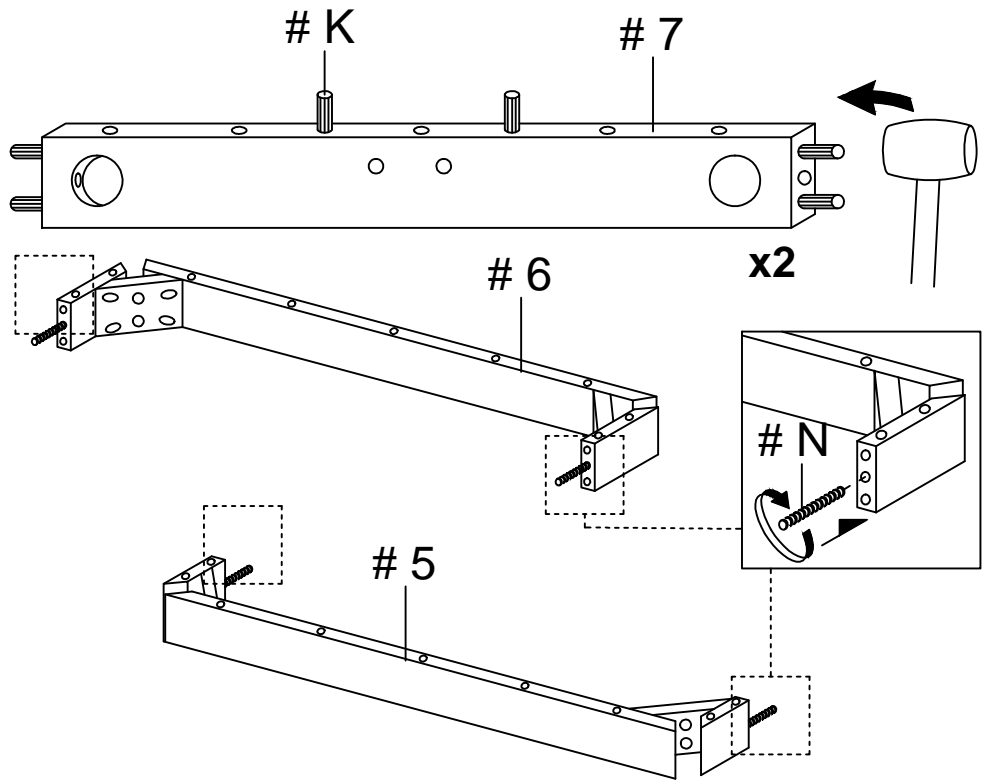

4

- Part #2 x1pc
- Part #3 x1pc
- Part #4 x2pcs

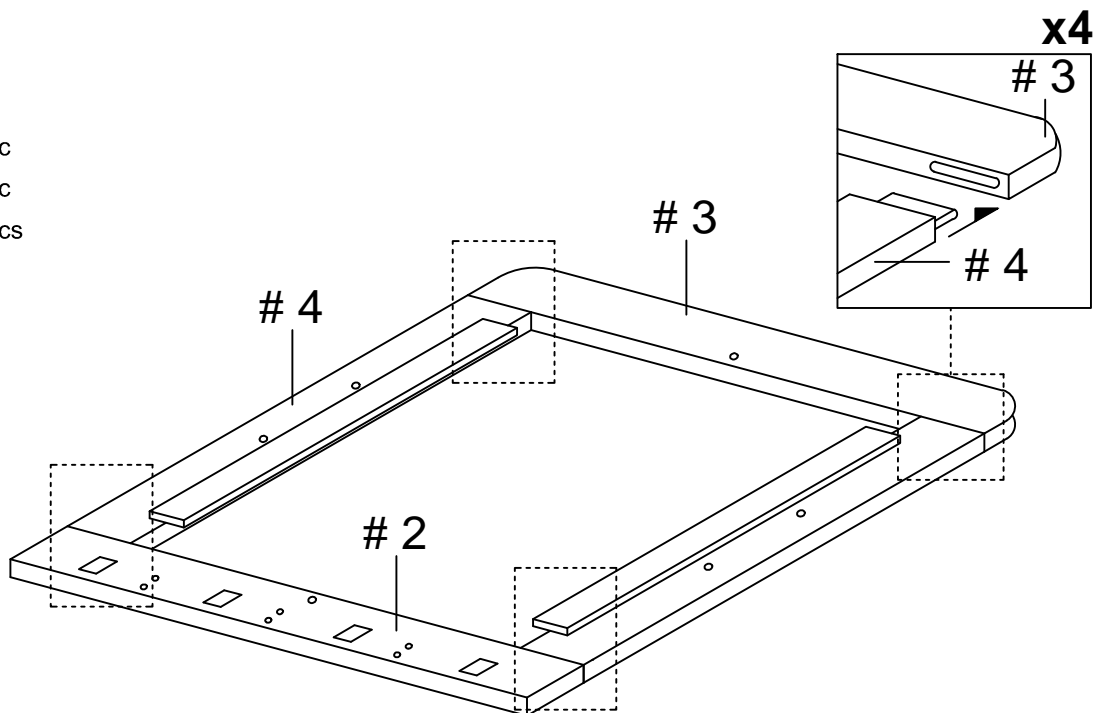

ASSEMBLY INSTRUCTIONS

5

Part #4 x2pcs

Part #7 x2pcs

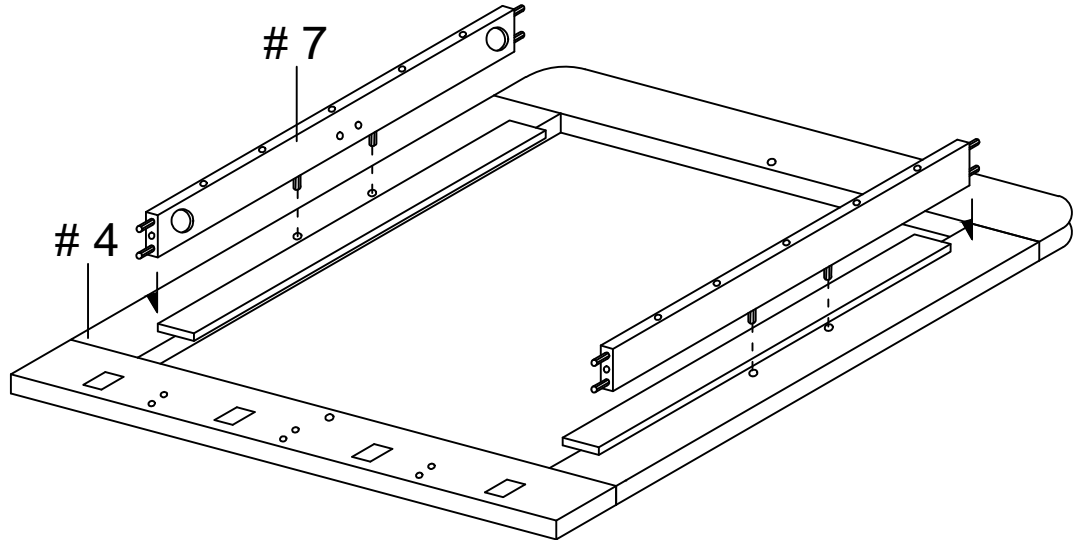

6

Part #5 x1pc

Part #6 x1pc

Part #7 x2pcs

Hardware #M x4pcs

Hardware #O x4pcs

Hardware #Q x1pc

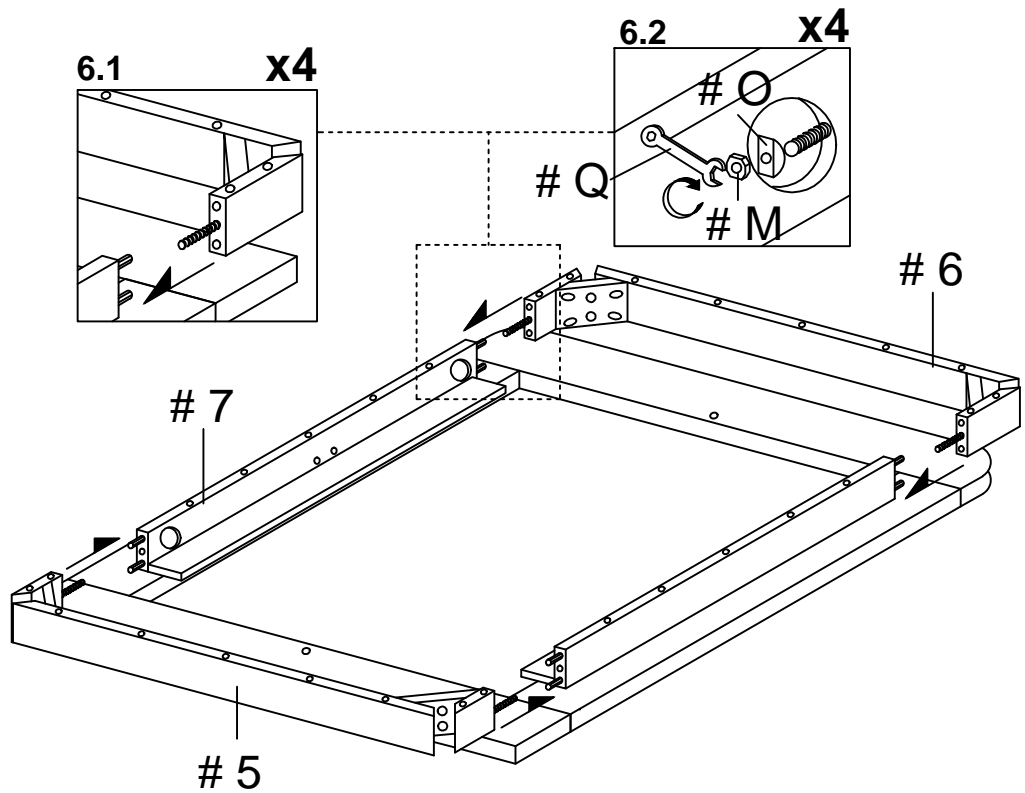

ASSEMBLY INSTRUCTIONS

7

- Part #5 x1pc
- Part #6 x1pc
- Part #7 x2pcs
- Hardware #J x28pcs

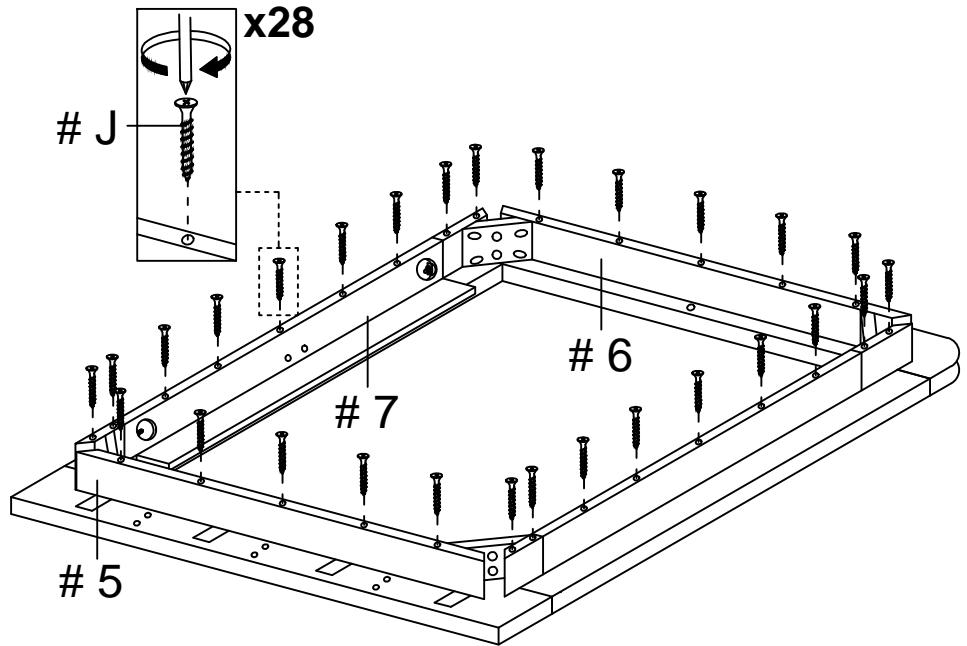

8

- Part #5 x1pc
- Part #6 x1pc
- Part #7 x2pcs
- Part #13 x 4pcs
- Hardware #E x8pcs
- Hardware #H x8pcs
- Hardware #I x8pcs
- Hardware #S x1pc

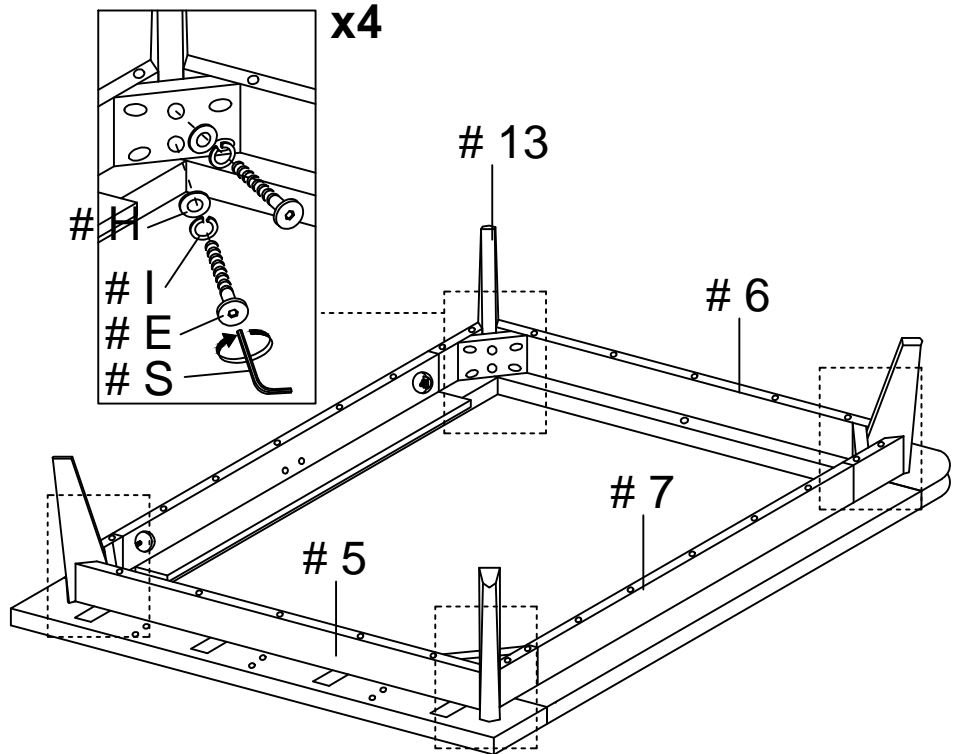

ASSEMBLY INSTRUCTIONS

9

- Part #2 x1pc
- Part #3 x1pc
- Part #8 x1pc
- Hardware #C x2pcs
- Hardware #F x2pcs
- Hardware #G x2pcs
- Hardware #R x1pc

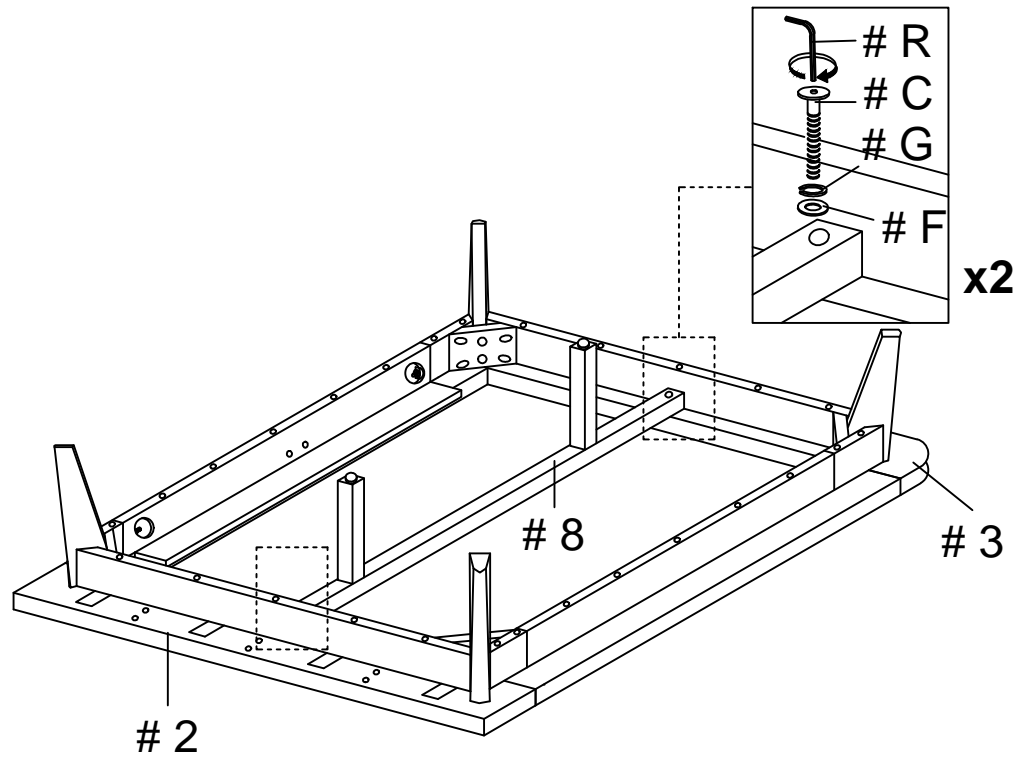

10

- Part #7 x2pcs
- Part #10 x1pc
- Hardware #A x4pcs
- Hardware #F x4pcs
- Hardware #G x4pcs
- Hardware #R x1pc

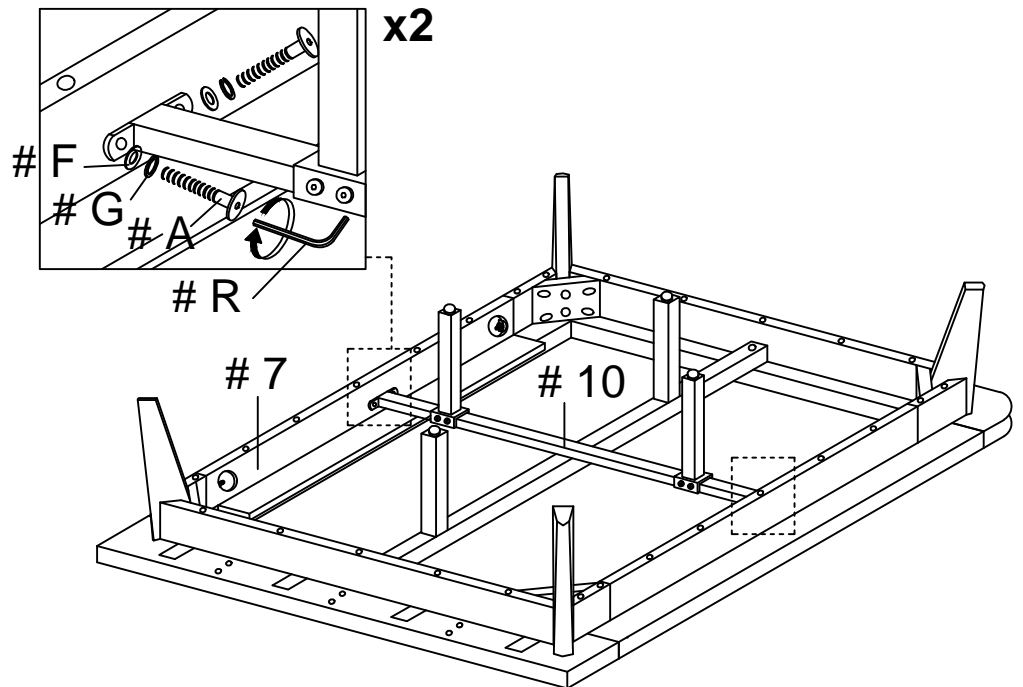

ASSEMBLY INSTRUCTIONS

11

- Part #2 x1pc
- Part #5 x1pc
- Part #12 x4pcs
- Hardware #J x8pcs

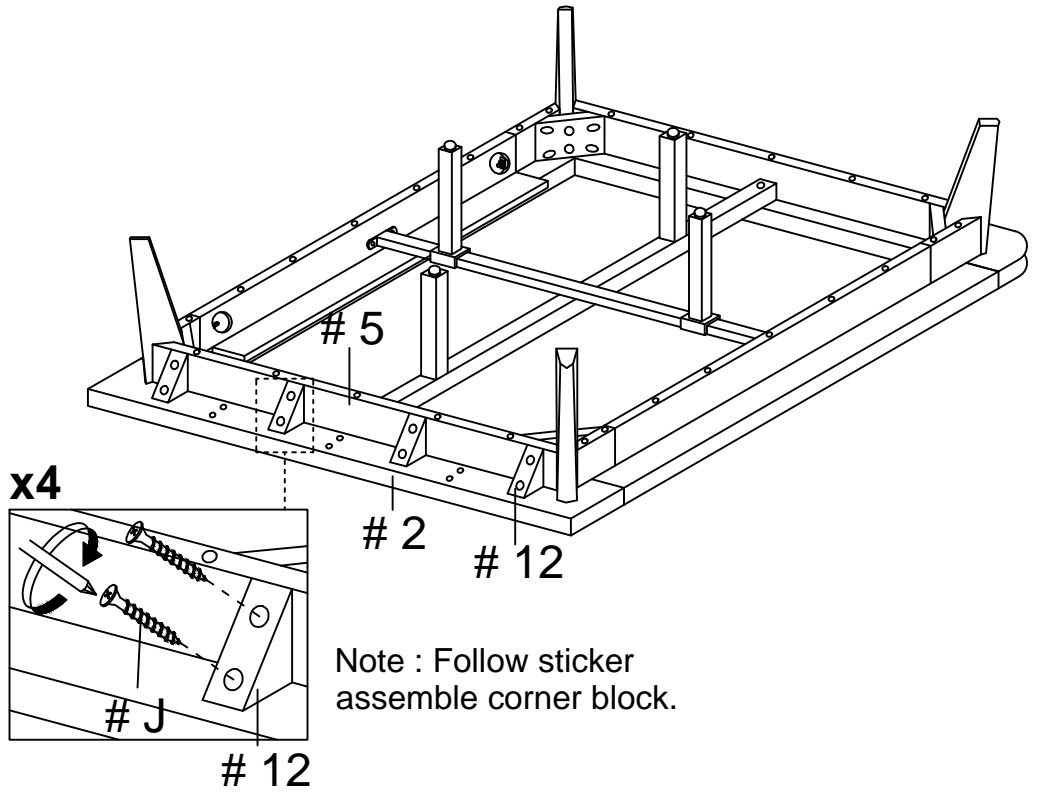

12

- Part #2 x1pc
- Part #4 x2pcs
- Hardware #T x2pcs
- Hardware #U x12pcs

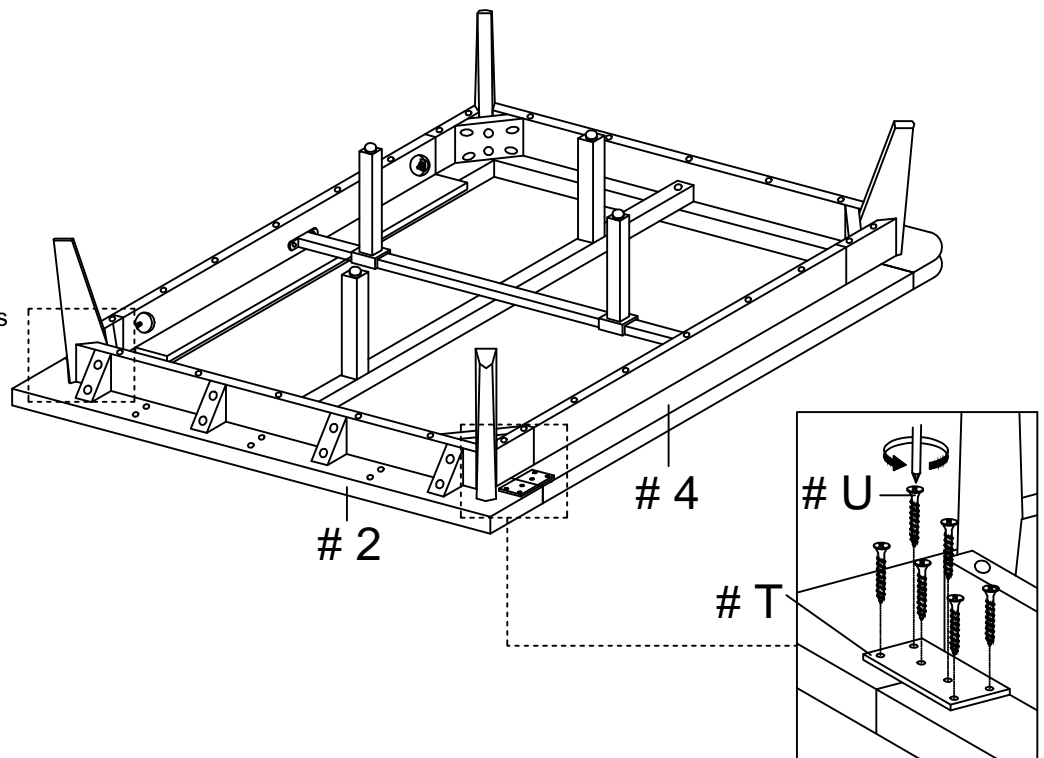

ASSEMBLY INSTRUCTIONS

13

- Part #2 x1pc
- Part #15 x3pcs
- Hardware #D x6pcs
- Hardware #H x6pcs
- Hardware #I x6pcs
- Hardware #S x1pc

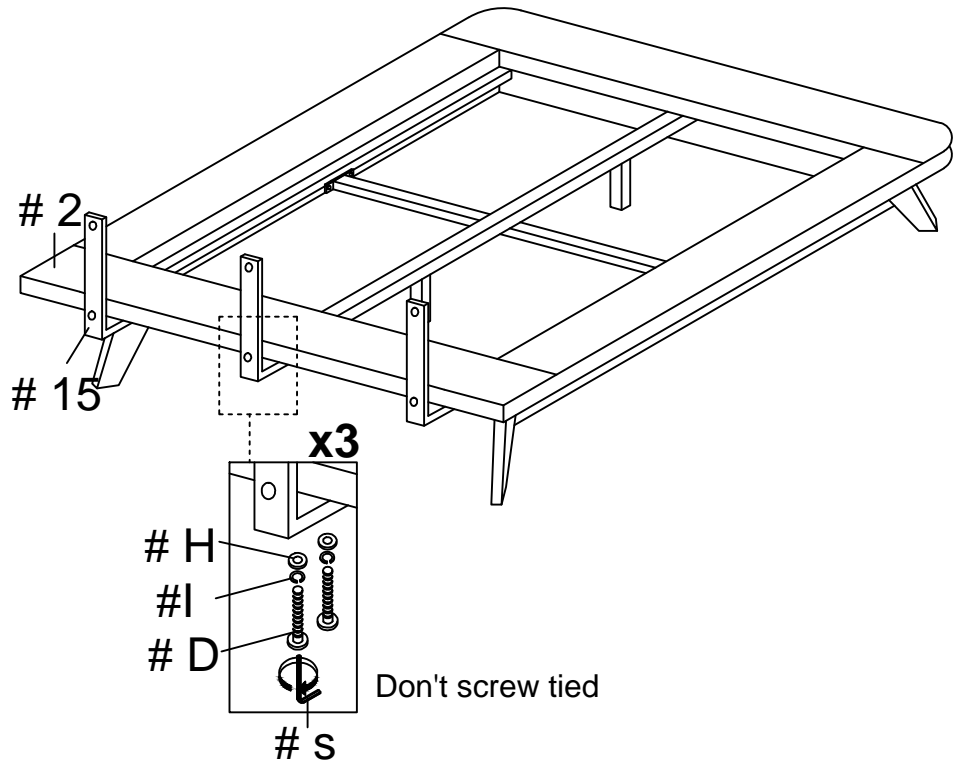

14

- Part #1 x1pc
- Part #15 x3pcs
- Hardware #D x6pcs
- Hardware #H x6pcs
- Hardware #I x6pcs
- Hardware #S x1pc

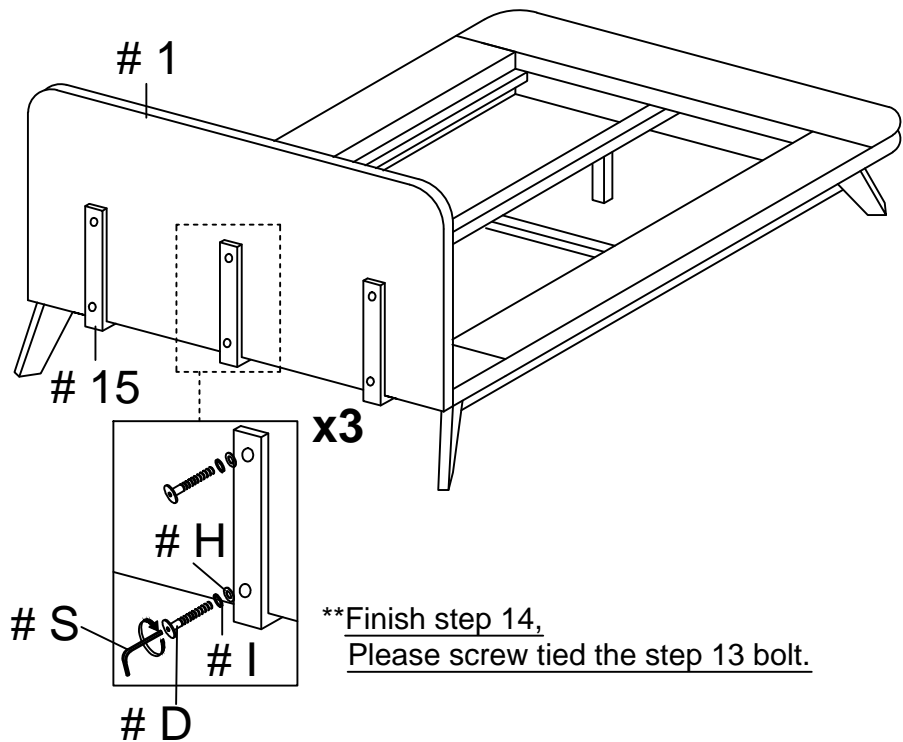

ASSEMBLY INSTRUCTIONS

15

Part **#14** x1set
Hardware **#J** x9pcs

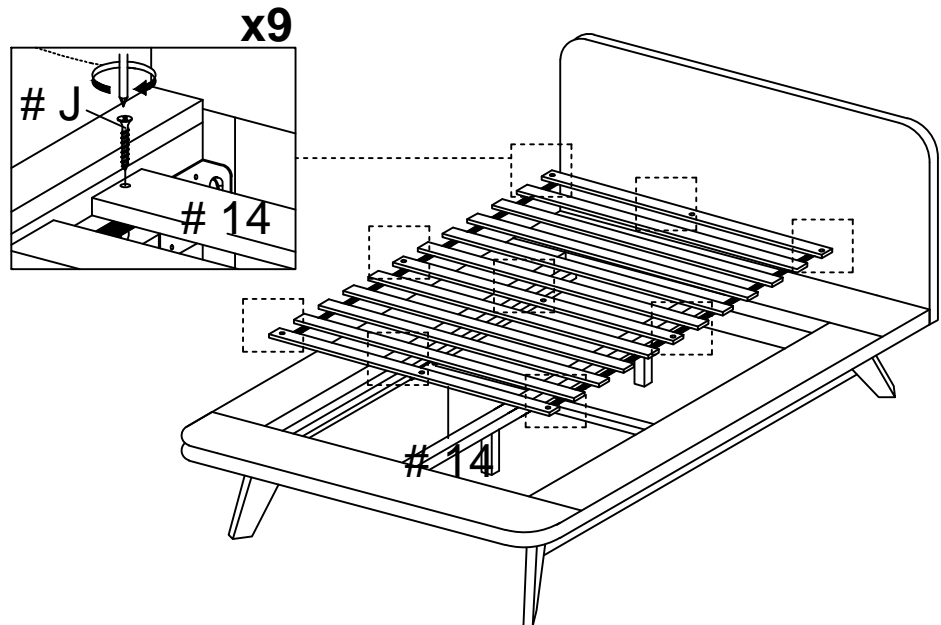

16

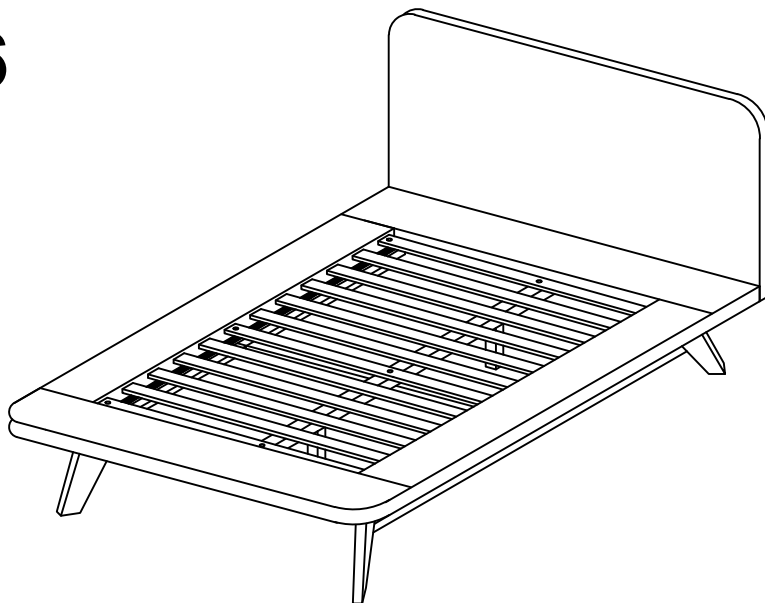

ASSEMBLY COMPLETED



Please ensure the furniture rests on an even and flat surface. If the product wobbles or feels loose, double-check all bolts and/or screws are properly tightened and secured.



Keep this handy!

Please retain this instruction manual and any order-related information for future reference.

ASSEMBLY INSTRUCTIONS

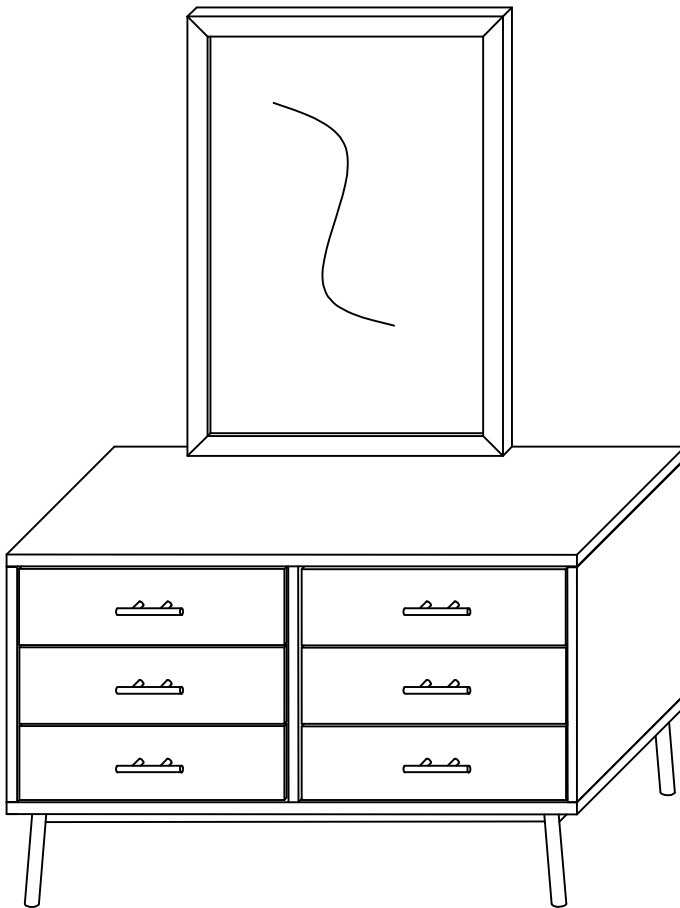

TOOLS REQUIRED



Allen Wrench
(Included)



Phillips Screwdriver
(Not Included)



2 – Persons
Recommended

ASSEMBLY RATING

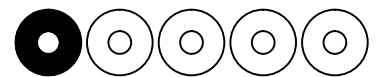

EASY ————— DIFFICULT

The Assembly Rating is a 5-point system showing the level of effort needed to assemble a specific product.



CHECK BEFORE STARTING



Are you missing anything?

Double-check all parts, hardware and accessories listed on Page 6 are accounted for.



Should we send any replacements?

Are there any irregularities or flaws in the parts? We can send replacements!



Check out our Quick Tips!

We recommend reviewing the pre-assembly handouts. Even experts need a refresher now and then!



Prep Time!

Please review the assembly instructions and all diagrams prior to assembling. Set up your workspace by laying the parts and hardware out separately, then begin!

PRE ASSEMBLY INTRODUCTION

We understand building ready-to-assemble furniture can be a challenging experience for some. To help avoid confusion, we have provided some helpful tips that may speed up the process.

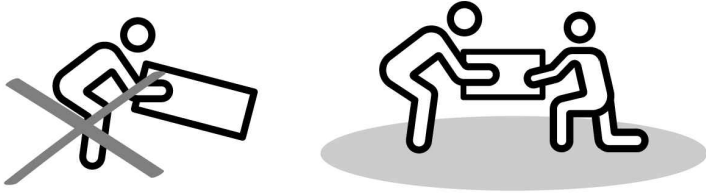

Teamwork

ALWAYS have at least two people to help with transporting and assembling the product to avoid potential injury and/or damage.

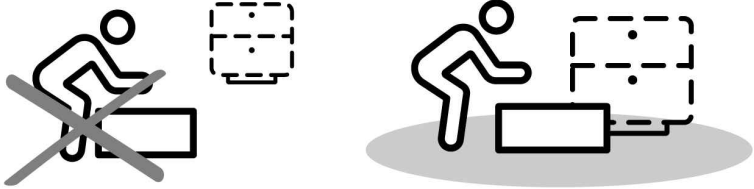

Suitable Location

Assembling near the area of the intended location is highly recommended.



Sufficient Space

Make sure you have enough space to move around during the assembly.

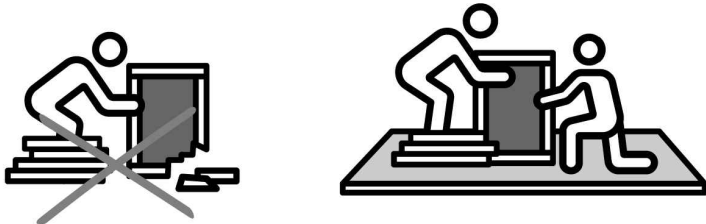

Avoid Scratches

Use cardboard, blankets or a carpeted area while assembling furniture to prevent scratches.

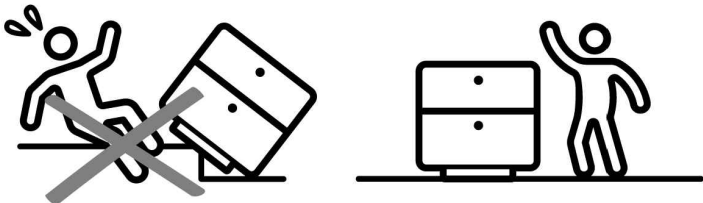

Flat Surface

Make sure the furniture rests on a flat and level surface with each leg evenly touching the floor.

ASSEMBLY AND CARE ADVICE



FAILURE TO FOLLOW THE GUIDELINES BELOW MAY RESULT IN INJURY AND/OR PROPERTY DAMAGE.



Position each part correctly and insert screws or bolts into their respective holes.



Turn clockwise to tighten and only tighten when step is completed or when instructed to do so.



Use the appropriate hand tools or power tools for assembly. Select steps, such as tightening screws and/or bolts, may require hand tools to avoid causing damage during assembly.



Save the instructions and store any supplied tools for later maintenance.



After two weeks, check and tighten any loose hardware and repeat again every six months thereafter.

IT IS THE USER'S RESPONSIBILITY TO MAINTAIN THE FURNITURE. THE HARDWARE MAY LOOSEN OVER TIME AND MAY CAUSE THE FURNITURE TO BE WOBBLY AND UNABLE TO SUPPORT ITS INTENDED WEIGHT CAPACITY. THIS MAY LEAD TO COLLAPSE AND MAY CAUSE SERIOUS INJURY.

MIRROR



- Please keep instructions for future reference.
- Check the quantity and irregularity of parts and hardware before you start.

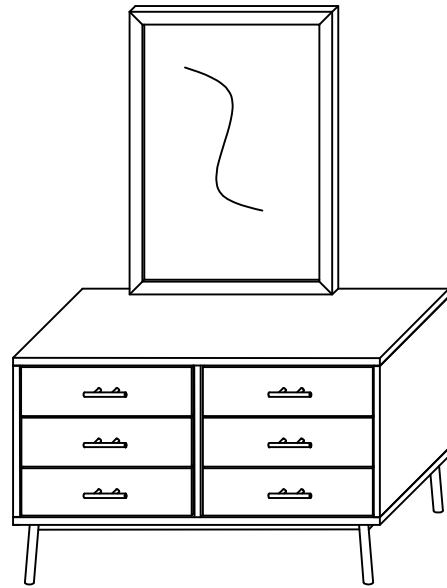

PARTS

#1 1pc



Dresser

#2 1pc

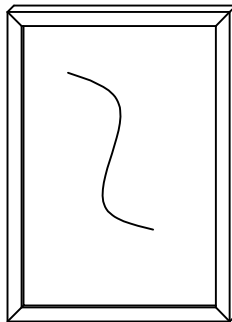

Mirror

#3 2pcs



Board Support

HARDWARE

#A 8pcs



Jcbc Bolt M6 x 35mm

#B 1pc

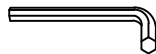

Allen Wrench

ASSEMBLY INSTRUCTIONS

1

- Part #1 x1pc
- Part #2 x1pc
- Part #3 x2pcs
- Hardware #A x8pcs
- Hardware #B x1pc

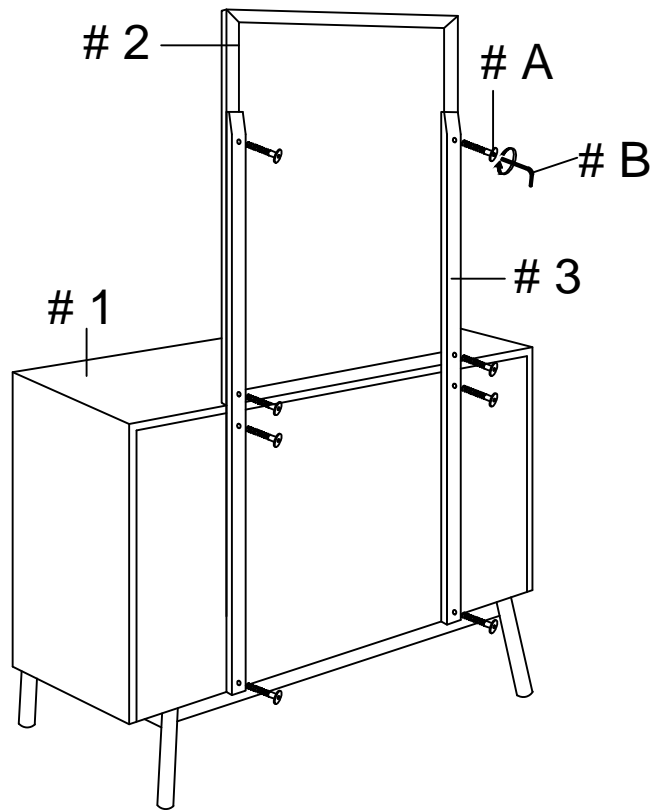

2

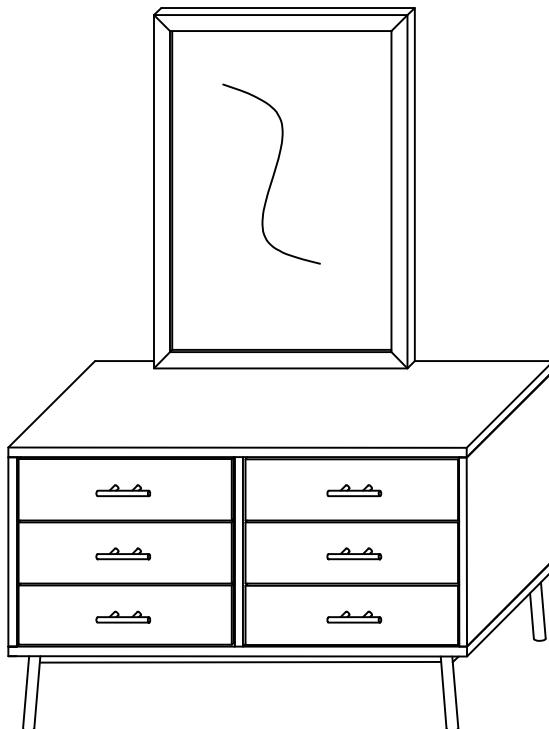

**ASSEMBLY
COMPLETED**



Please ensure the furniture rests on an even and flat surface. If the product wobbles or feels loose, double-check all bolts and/or screws are properly tightened and secured.



Keep this handy!

Please retain this instruction manual and any order-related information for future reference.

ASSEMBLY INSTRUCTIONS

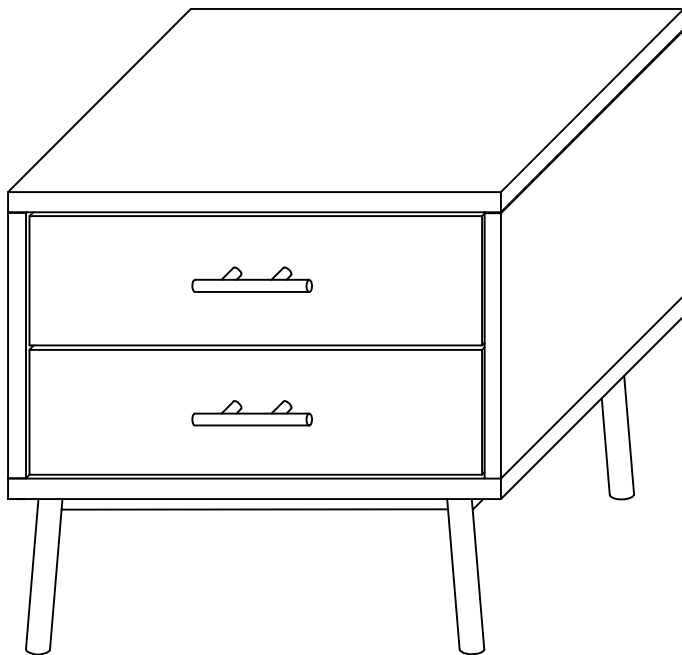

TOOLS REQUIRED



Allen Wrench

(Included)



Phillips
Screwdriver

(Not Included)



2 – Persons
Recommended

ASSEMBLY RATING

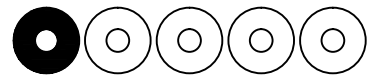

EASY ————— DIFFICULT

The Assembly Rating is a 5-point system showing the level of effort needed to assemble a specific product.



CHECK BEFORE STARTING



Are you missing anything?

Double-check all parts, hardware and accessories listed on Page 6 are accounted for.



Check out our Quick Tips!

We recommend reviewing the pre-assembly handouts. Even experts need a refresher now and then!



Should we send any replacements?

Are there any irregularities or flaws in the parts? We can send replacements!



Prep Time!

Please review the assembly instructions and all diagrams prior to assembling. Set up your workspace by laying the parts and hardware out separately, then begin!

PRE ASSEMBLY INTRODUCTION

We understand building ready-to-assemble furniture can be a challenging experience for some. To help avoid confusion, we have provided some helpful tips that may speed up the process.



Teamwork

ALWAYS have at least two people to help with transporting and assembling the product to avoid potential injury and/or damage.

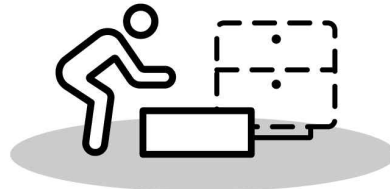
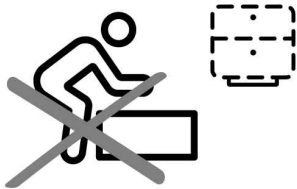

Suitable Location

Assembling near the area of the intended location is highly recommended.



Sufficient Space

Make sure you have enough space to move around during the assembly.



Avoid Scratches

Use cardboard, blankets or a carpeted area while assembling furniture to prevent scratches.

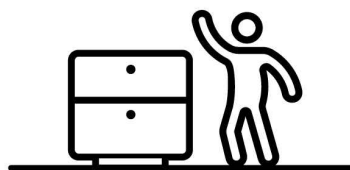
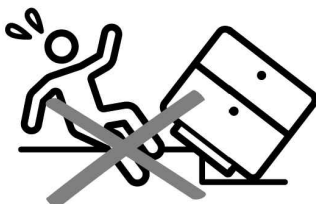

Flat Surface

Make sure the furniture rests on a flat and level surface with each leg evenly touching the floor.

ASSEMBLY AND CARE ADVICE



FAILURE TO FOLLOW THE GUIDELINES BELOW MAY RESULT IN INJURY AND/OR PROPERTY DAMAGE.



Position each part correctly and insert screws or bolts into their respective holes.



Turn clockwise to tighten and only tighten when step is completed or when instructed to do so.



Use the appropriate hand tools or power tools for assembly. Select steps, such as tightening screws and/or bolts, may require hand tools to avoid causing damage during assembly.



Save the instructions and store any supplied tools for later maintenance.



After two weeks, check and tighten any loose hardware and repeat again every six months thereafter.

IT IS THE USER'S RESPONSIBILITY TO MAINTAIN THE FURNITURE. THE HARDWARE MAY LOOSEN OVER TIME AND MAY CAUSE THE FURNITURE TO BE WOBBLY AND UNABLE TO SUPPORT ITS INTENDED WEIGHT CAPACITY. THIS MAY LEAD TO COLLAPSE AND MAY CAUSE SERIOUS INJURY.

NIGHTSTAND



- Please keep instructions for future reference.
- Check the quantity and irregularity of parts and hardware before you start.

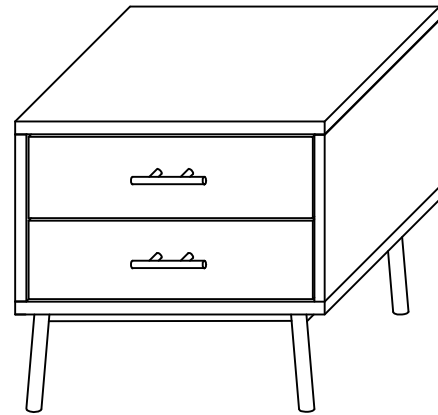

PARTS

#1 4pcs



Leg

#2 1pc

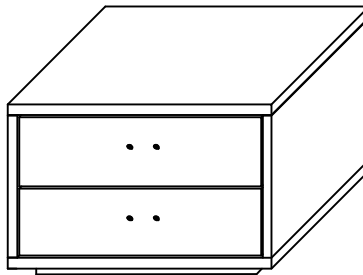

Nightstand

HARDWARE

#A 4pcs



Jcbc Bolt M6 x 60mm

#B 4pcs



M6 Flat Washer

#C 4pcs



M6 Spring Washer

#D 1pc

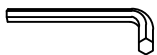

Allen Wrench

ASSEMBLY INSTRUCTIONS

1

- Part #1 x4pcs
- Part #2 x1pc
- Hardware #A x4pcs
- Hardware #B x4pcs
- Hardware #C x4pcs
- Hardware #D x1pc

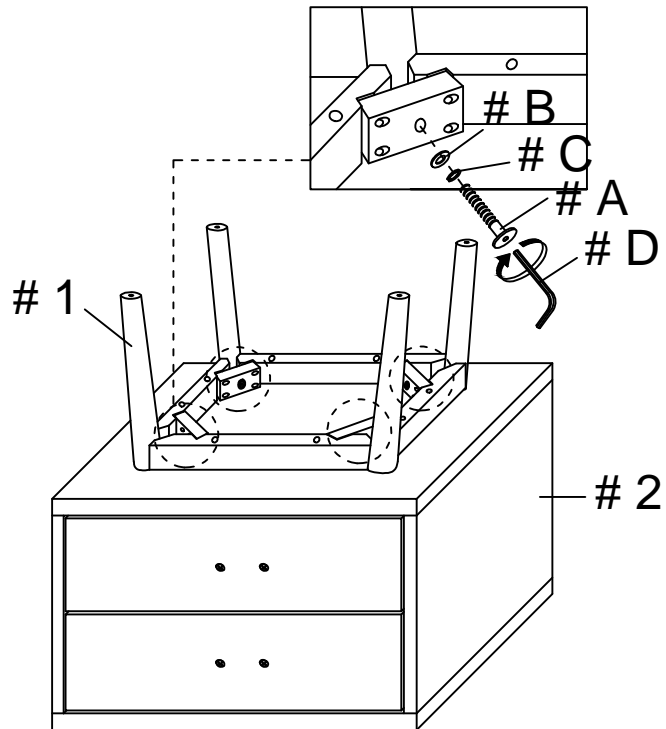

2

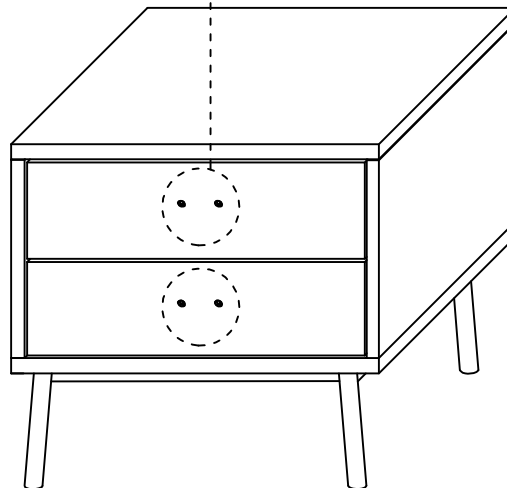
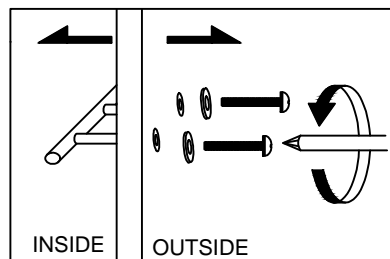

ASSEMBLY INSTRUCTIONS

Note :
Hold the handle flat and then tighten the screws

3

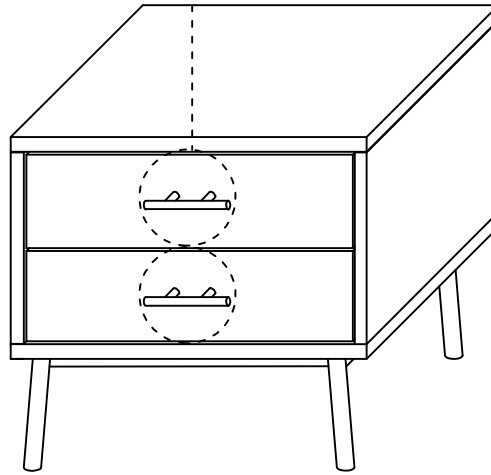
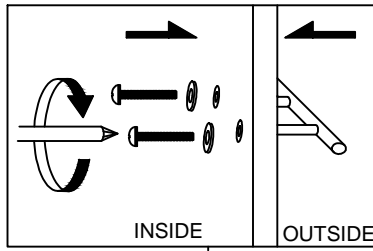

4

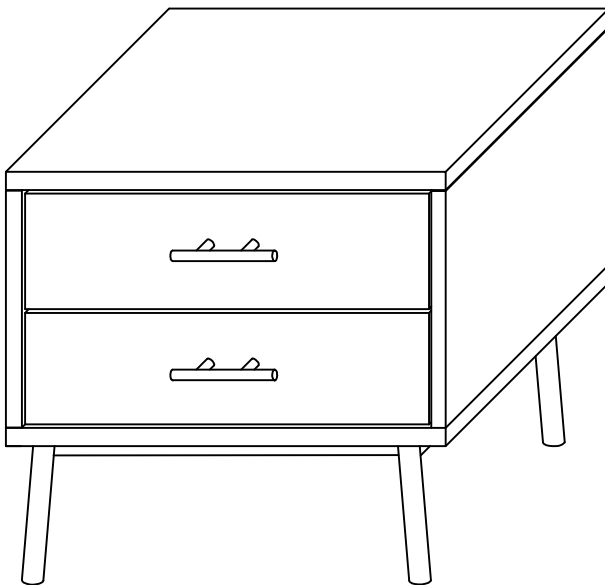

ASSEMBLY COMPLETED



Please ensure the furniture rests on an even and flat surface. If the product wobbles or feels loose, double-check all bolts and/or screws are properly tightened and secured.



Keep this handy!

Please retain this instruction manual and any order-related information for future reference.