

Stock Code: **50080LEDDL-BS/OPL**

Collection: **Conga**

**PRODUCT INFORMATION**

Base: 50080 Parent: 50080LEDDL  
Mounting Type: Ceiling UPC: 641594220780  
Finish: Brushed Steel  
Diffuser: Opal

**PRODUCT MEASUREMENTS**

<b>FIXTURE**</b>	<b>BACKPLATE / CANOPY**</b>
Length:	Length
Width:	Width:
Diameter 16"	Diameter:
Height: 4.5"	Height:
Extension:	
Overall Height:	

**TECHNICAL SPECIFICATIONS**

**SPECIFICATIONS**

Frame Material: Metal  
Diffuser Material: Glass  
Lamping Type: E-26 (Replaceable LED Jbox: Standard  
Lamping Base: E-26 Lamp Wattage: 10 W  
Lamp Quantity: 2 Total Wattage: 20 W  
Voltage: 120v Lamps Included: Yes

**QUALIFICATIONS**

Location Rating Damp  
Certification: ETL (US/Canada) Listed  
ADA Compliant: No Energy Star: No  
JA8 Compliant: Yes Emergency Lighting: No  
Marine Grade Finish: No  
Warranty\*\*: 1 Year

**PHOTOMETRICS**

Dimmable: Yes Nominal Lumens: 1600 Lm  
CRI: 90 Delivered Lumens: N/A  
CCT: 3000K  
Recommended Dimmers:  
(MLV)COOPER Aspire 9530SW; (TRIAC)LEGRAND Titan CD703-PW; (ELV)LUTRON Skylark SELV-300P

**ADDITIONAL NOTES**

Custom Finish 5 Piece Minimum Order Quantity

Project Name: \_\_\_\_\_

Location: \_\_\_\_\_

Type: \_\_\_\_\_

Quantity: \_\_\_\_\_

Notes: \_\_\_\_\_



**LINE DRAWING**

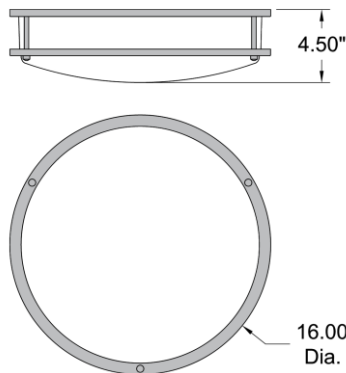

**IES FILE**

In addition to Access Lighting's purchase and warranty terms and conditions, by signing below or placing an order, you agree that you are authorized to bind the entity placing any order and acknowledge the following: All of sizes and measurements are approximate and all images are for illustrative purposes only. In the event of an inconsistency, the "Product Measurements" section controls. There also may be slight differences in the colors and designs compared to the displayed and printed images.

Signature: \_\_\_\_\_

Print Name \_\_\_\_\_ Date: \_\_\_\_\_

**Toll Free 800-828-5483 www.AccessLighting.com**

301 Piedmont Grove Park, Suite A, Greenville, SC 29611



\*\* NOTE: All measurements are rounded up to the 1/4 inch. There is no warranty on any replaceable bulbs, even if included with the fixture. Copyright Access Lighting Corp. All information is subject to change without notice. 2/18/2024 50080LEDDL-BS\_OPL.pdf