

MS040700TX

Blankenship Media Console

Assembly Instructions



Southern
ENTERPRISES

For assistance with assembly, contact:
Southern Enterprises, Inc.
Customer Service: 1-800-633-5096
service@seidal.com
www.seifurniturestore.com

PO#:

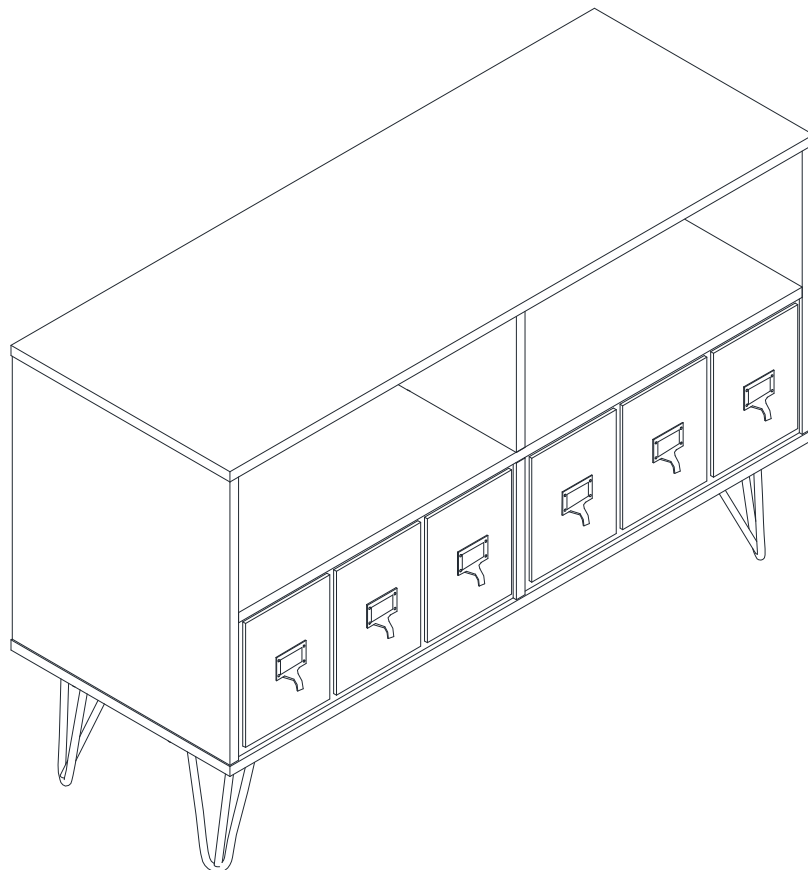







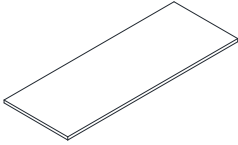
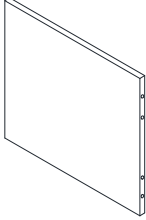
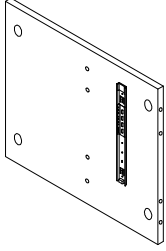
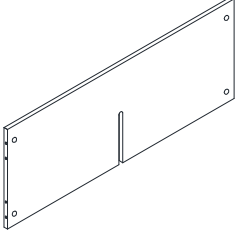
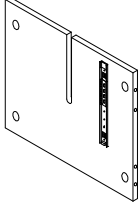
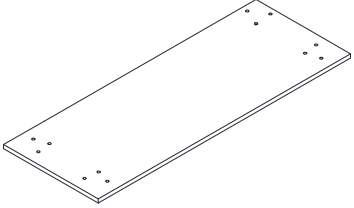
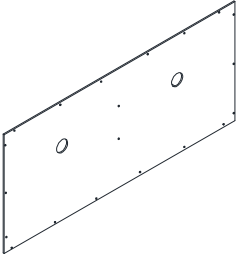
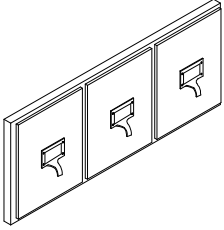
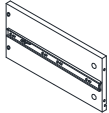
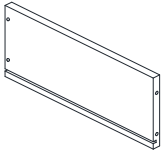
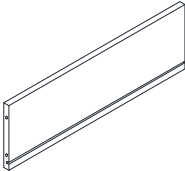
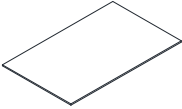

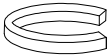

Blankenship Media Console

Parts List

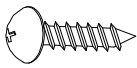
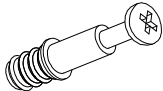
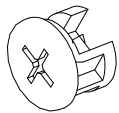
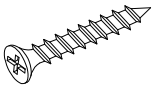
Please check packaging for all parts and hardware before discarding. Unpack and lay parts on clean, padded surface like carpet or a blanket. Check that you have all parts indicated. Call customer service if any hardware is missing. Before beginning assembly, carefully study the diagrams below and sort your hardware according to the pictures. Using the incorrect hardware will cause damage.

1)  Top Panel	2)  Left Side Panel	3)  Right Side Panel
4)  Shelf Panel	5)  Middle Panel	6)  Bottom Panel
7)  Back Panel	8)  Drawer Front Panel	9)  Drawer Left Side Panel
10)  Drawer Right Side Panel	11)  Drawer Back Panel	12)  Drawer Bottom Panel

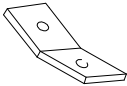
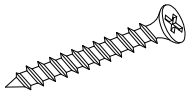
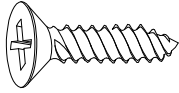
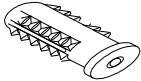
<p>13)</p>  <p>Quantity of 4</p> <p>Leg</p>		
<p>A)</p>  <p>Quantity of 16</p> <p>Cam Bolts</p>	<p>B)</p>  <p>Quantity of 16</p> <p>Cam Locks</p>	<p>C)</p>  <p>Quantity of 16</p> <p>Wood Dowels Dia. 5/16"x1-1/4"</p>
<p>D)</p>  <p>Quantity of 12</p> <p>Bolt Dia. 1/4x3/4" L</p>	<p>E)</p>  <p>Quantity of 12</p> <p>Spring Washer Dia.1/4"</p>	<p>F)</p>  <p>Quantity of 12</p> <p>Flat washer Dia.1/4" x3/4"</p>
<p>G)</p>  <p>Quantity of 1</p> <p>Allen Wrench</p>	<p>H)</p>  <p>Quantity of 20</p> <p>Screw Dia. 1/8" x 5/8"L</p>	<p>I)</p>  <p>Quantity of 8</p> <p>Cam Bolts</p>
<p>J)</p>  <p>Quantity of 8</p> <p>Cam Locks</p>	<p>K)</p>  <p>Quantity of 8</p> <p>Screw Dia. 5/32" x 1L</p>	<p>L)</p>  <p>Quantity of 2</p> <p>Plastic Strap</p>

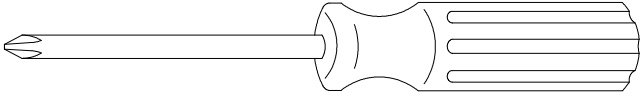
<p>M) Quantity of 4</p>  <p>Bracket</p>	<p>N) Quantity of 2</p>  <p>Screws Dia. 1/8"x1-1/2"L</p>	<p>O) Quantity of 2</p>  <p>Screws Dia. 1/8"x5/8"L</p>
<p>P) Quantity of 2</p>  <p>Anchor</p>	<p>Q) Quantity of 14</p>  <p>Adhesive Pad</p>	
<p>Care and Cleaning Instructions: Before using, wipe with a clean, dry cloth. Periodically apply furniture wax to renew the finish. Avoid rubbing or scratching the surface with rough or abrasive objects.</p>		<p>For replacement parts or questions, please call SEI Customer Service at 1-800-633-5096.</p>
<p>Assembly Tool Required: No.2 Phillips Screwdriver, Hammer (Not Included)</p>		

Blankenship Media Console

Assembly Instructions

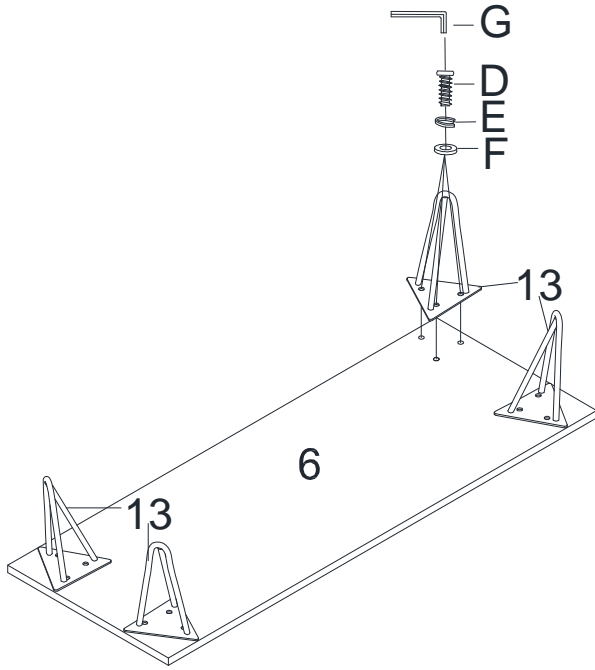

Figure 1

Align Bolts **(D)** by hand.

Attach Legs **(13)** to the Bottom Panel **(6)** with Bolts **(D)**, Spring Washers **(E)**, and Flat Washers **(F)**.

Tighten Bolts **(D)** with Allen Wrench **(G)**.

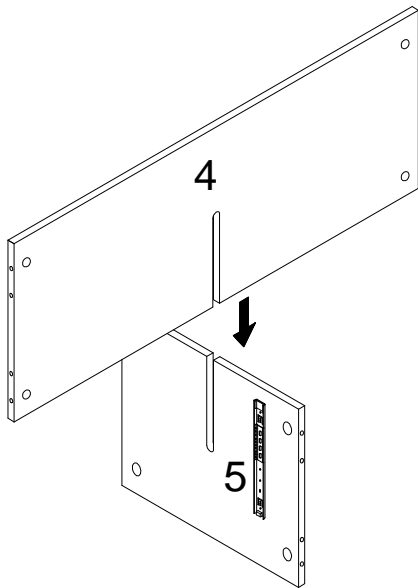
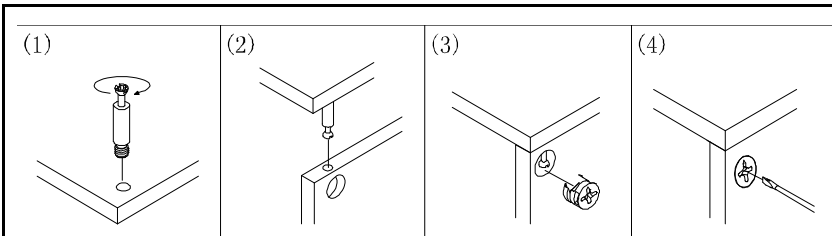

Figure 2

Attach the Shelf Panel **(4)** to the Middle Panel **(5)**.



Please do not overtighten cam locks. Stop when they feel secure.

Align Cam Bolts **(A)** by hand.

Insert Cam Locks **(B)** into corresponding holes on Shelf Panel **(4)**.

Screw Cam Bolts **(A)** into threaded holes on Side Panels **(2/3)**.

Attach Side Panels **(2/3)** to Shelf Panel **(4)** by inserting Cam Bolts **(A)** and Wood Dowels **(C)** into corresponding holes until all panels meet.

Tighten Cam Bolts **(A)** by rotating Cam Locks **(B)** clockwise using Phillips screwdriver (not included).

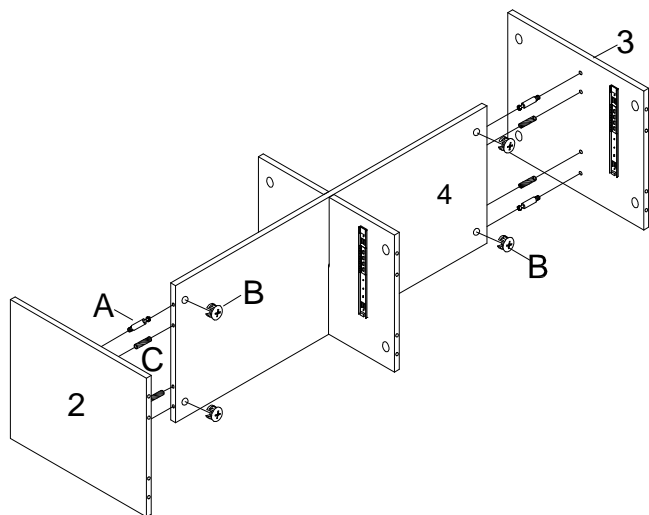

Figure 3

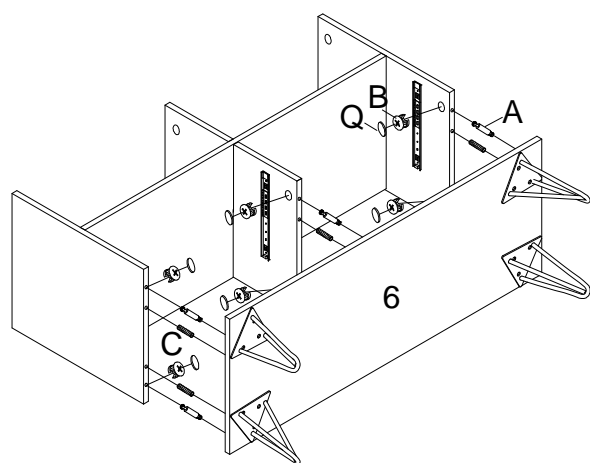

Figure 4

Align Cam Bolts **(A)** by hand.

Insert Cam Locks **(B)** into corresponding holes on Side Panels **(2/3)** & Middle Panel **(5)**.

Screw Cam Bolts **(A)** into threaded holes on Bottom Panel **(6)**.

Attach Bottom Panel **(6)** to Side Panels **(2/3)** & Middle Panel **(5)** by inserting Cam Bolts **(A)** and Wood Dowels **(C)** into corresponding holes until all panels meet.

Tighten Cam Bolts **(A)** by rotating Cam Locks **(B)** clockwise using Phillips screwdriver (not included).

Cover Cam Locks **(B)** with Cotton Mats **(Q)** provided.

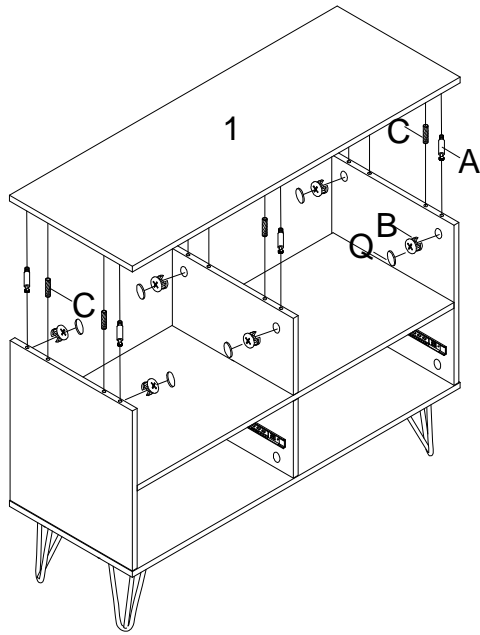

Figure 5

Start with finger to help align Cam Bolts.

Insert Cam Locks **(B)** into corresponding holes on Side Panel **(2/3)** & Middle Panel **(5)**.

Screw Cam Bolts **(A)** into threaded holes on Top Panel **(1)**.

Attach Top Panel **(1)** to Side Panel **(2/3)** & Middle Panel **(5)** by inserting Cam Bolts **(A)** and Wood Dowel **(C)** into corresponding holes until all panels meet.

Tighten Cam Bolts **(A)** by rotating Cam Locks **(B)** clockwise using Phillips screwdriver.

Cover Cam Locks **(B)** with Adhesive Pads **(Q)**.

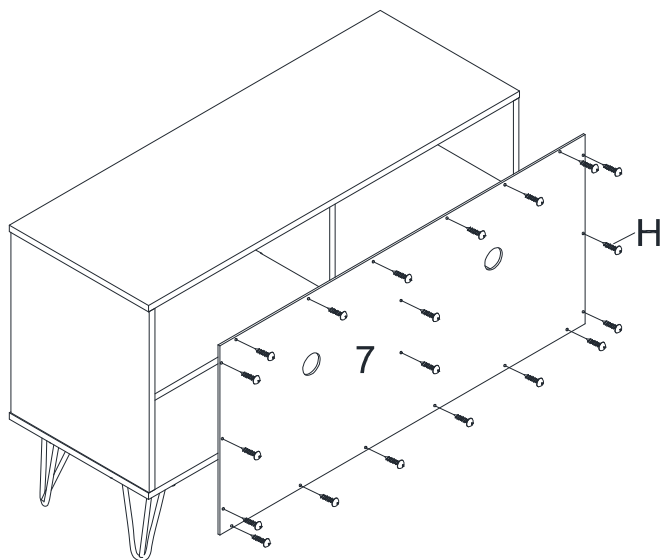

Figure 6

Attach Back Panels **(7)** to back of the unit with Screws **(H)**.

Tighten Screws **(H)** with Phillips screwdriver (not included).

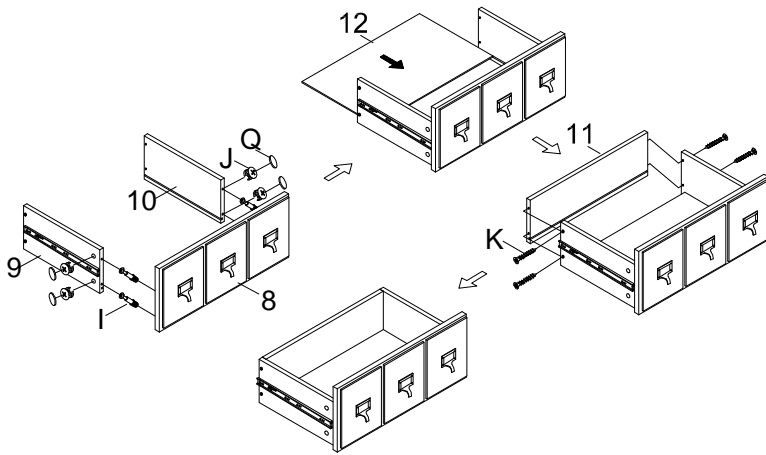

Figure 7

Attach Drawer Side Panels (9/10) to Drawer Front Panel (8) using Cam Bolts (I) and Cam Locks (J).

Cover Cam Locks (J) with Adhesive Pads (Q).

Attach Drawer Back Panel (11) to Side Panels (9/10) using Screws (K).

Insert Drawer Bottom Panel (12) into grooves of Panels (9/10/11).

Repeat this step for additional drawers.

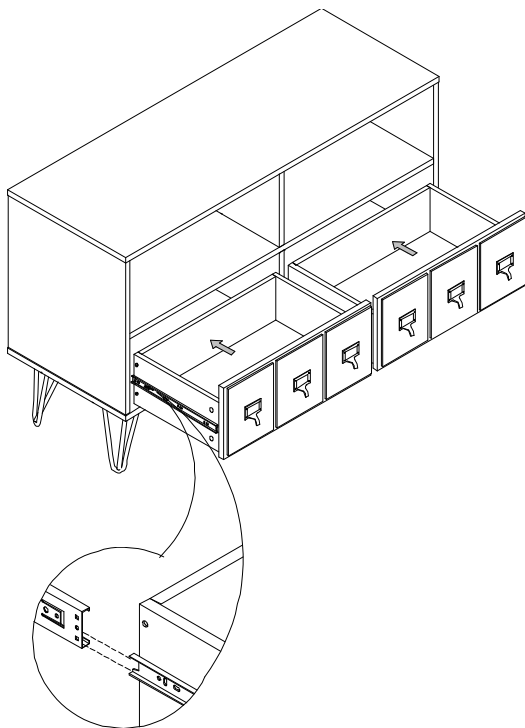

Figure 8

Insert assembled drawers into assembled unit from Figure 6.

Make sure drawers glide smoothly in and out.

Note: There is a lever located on male slide for bottom drawer slide. Push lever to either side in order to detach male slide from female slide.

Note: If drawer heights are off, loosen screws on male slide to adjust height of drawer(s).

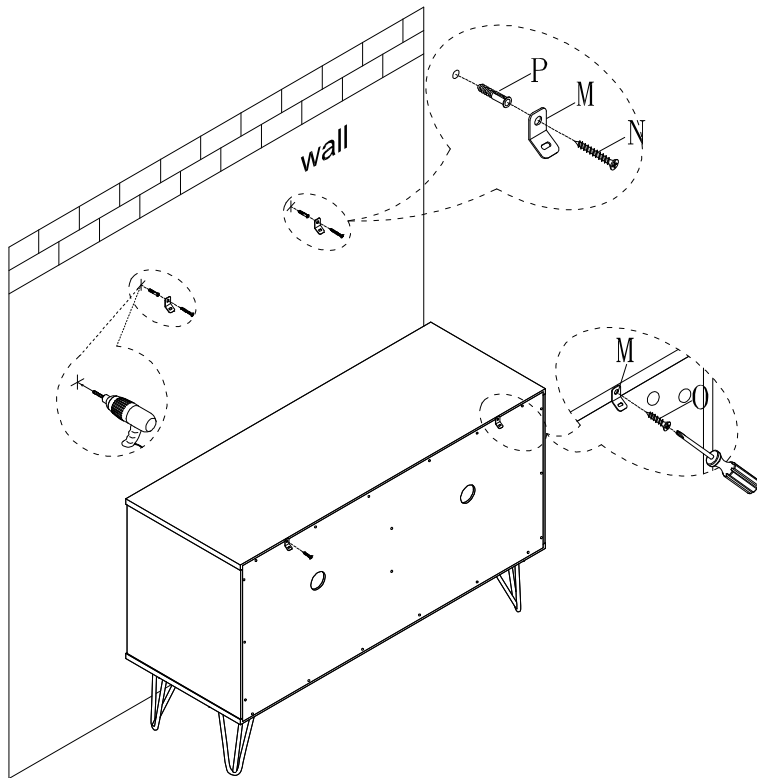

Figure 9

Attach Brackets **(M)** to Back Panel using Screws **(O)**.

Tighten Screws **(O)** using a Philips screwdriver (not included).

Mark two desired locations on wall.

Drill two 3/16" holes.

Insert Plastic Anchors **(P)** into the holes, tap lightly with hammer (not included) as needed.

Attach Brackets **(M)** to wall using Screws **(N)**.

Tighten Screws **(N)** using a Philips screwdriver (not included).

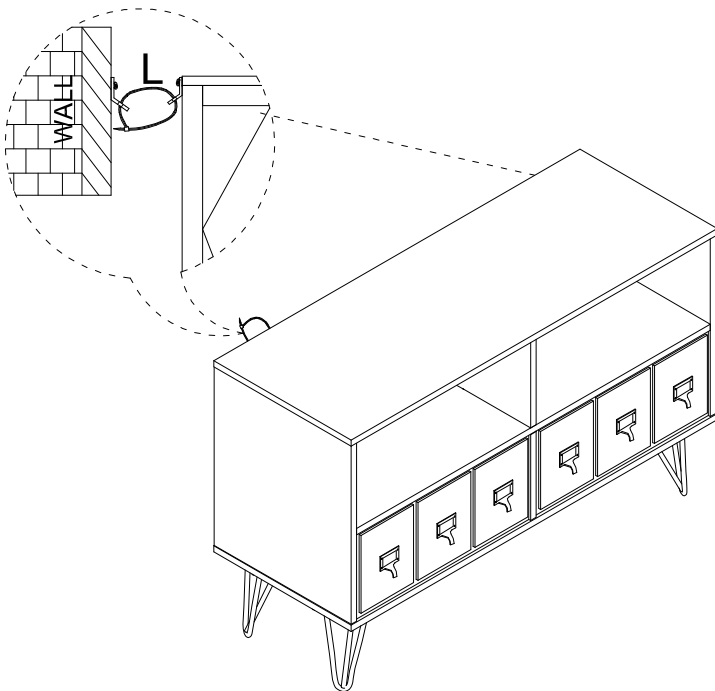

Figure 10

Move the media stand close to the wall.

Tie Brackets **(M)** together with Plastic Straps **(L)**.

Warning: Anti-tipping hardware must be used for this product to avoid tipping and injury.

Now your Blankenship Media Console is ready to use!

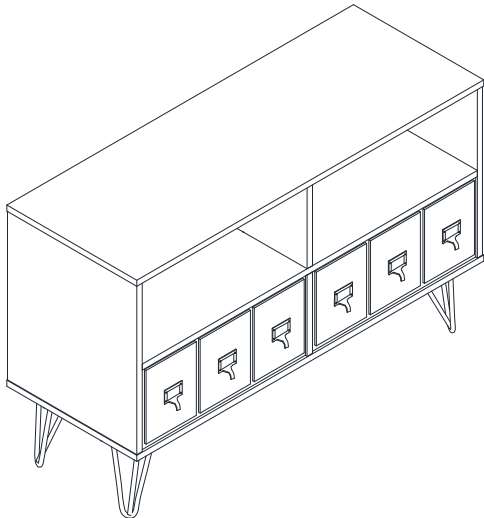

Figure 11



CAUTION

The top shelf of this cabinet is intended for plasma/LCD televisions. Max TV size is 50" flat screen and Max weight limit is 85 lb.

The top shelf is NOT INTENDED for tube televisions.

Each shelf should not be loaded with more than 20 lb. Each drawer should not be loaded with more than 15 lb.

DO NOT EXCEED RECOMMENDED LOAD. Use with products heavier than the maximum sizes and weights indicated may result in instability causing possible injury.

This unit contains a permanent warning sticker located on back panel.

Do not allow children under 16 years to move the media stand.

Model: MS040700 TX
Blankenship Media Console

Southern Enterprises, Inc
600 Freeport Parkway, Suite 200
Coppell, Texas, 75019
Manufacture Date: 11/25/2015

Parts Replacement Form

Customer Information

Name _____

Address _____

City/State/Zip Code _____

Phone Number _____

Please indicate where you purchased this item: Store/Website/Catalog

Please indicate color/size/style number:

Style No	Parts Letter	Parts Description	Quantity Needed
_____	_____	_____	_____
_____	_____	_____	_____
_____	_____	_____	_____

Please immediately examine this product carefully. Any request for missing parts or damage replacement must be received within 90 days of your receipt of the product. Replacement, if available, will be honored within this time frame. Parts will not be available for items arriving fully assembled. We do not recommend modifying product(s) and we are not responsible for any damages due to product modification(s). If damages or missing parts are not reported within 90 days of your receipt, we are under no obligation to provide parts or replacement merchandise.

For product issues, please contact Southern Enterprises at 800-633-5096 (toll-free) / 972-869-0111 (Dallas), Mon-Fri 9am – 4pm CST, or email us at service@seidal.com. Please ask for customer service representative for issues involving damages or replacement parts. Please ask for technical assistance representative for any issues with product and assembly/construction.

Please contact the retailer that you purchased from for returns.



Southern
ENTERPRISES

Customer Service: 1-800-633-5096
service@seidal.com

Southern Enterprises, Inc.
600 Freeport Parkway, Suite 200
Coppell, Texas 75019