

BED FRAME

ASSEMBLY INSTRUCTIONS
MODEL NO.:RYS201

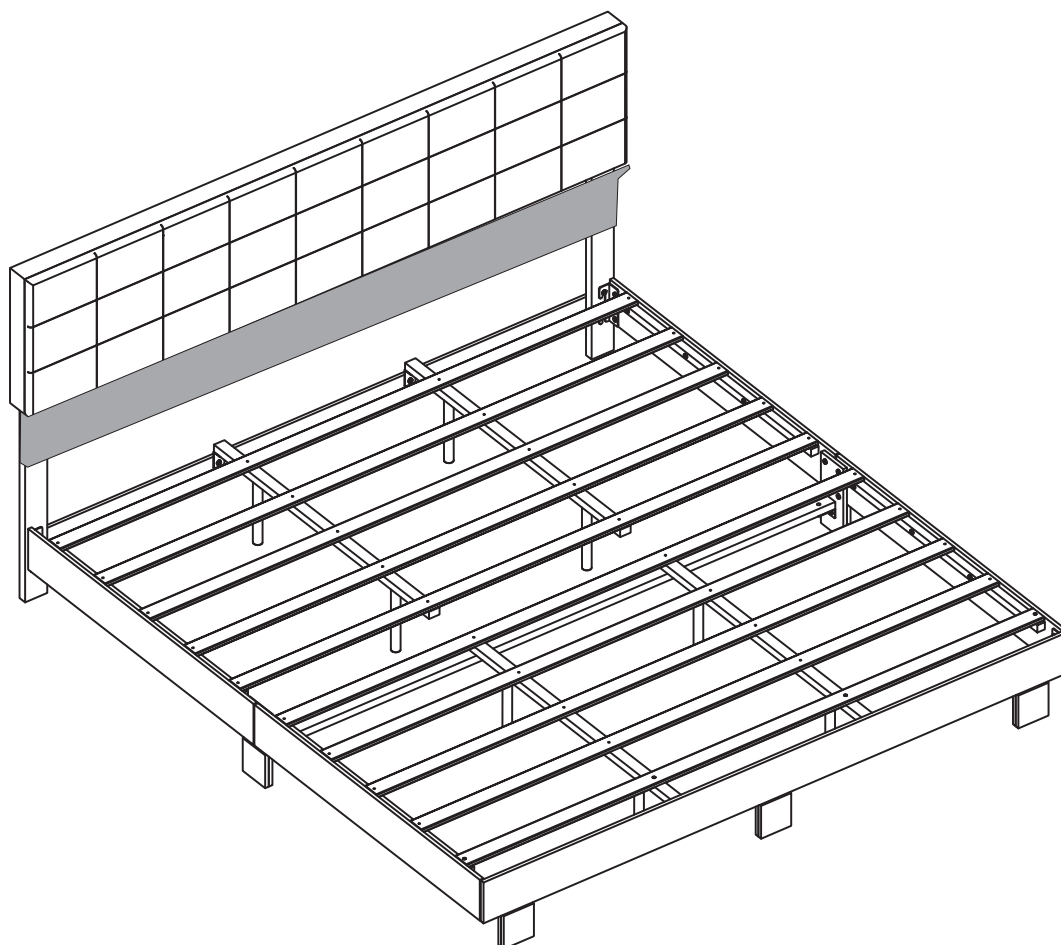

INSTALLATION VIDEO

Please scan QR code with iOS or Android phone camera,
click the link to play the installation video.

If QR code is damaged, please contact us to get installation video.

If no access for cell phone scanner, please try other APP.

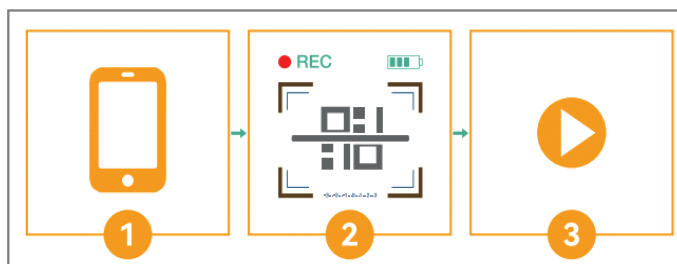

CAUTION:

- Please do not open the compress packaging until your sofa frame is completely assembled.
 - Compress cushions or pillows need to fully fluffed within 72 hours for your perfect use.
 - Please keep children away from plastic bag or any small pieces of stuff.
 - After assembly is completed, don't forget to pat the back cushions and seat cushions, make them recovering better. And wait 72 hours for fully rebound.
 - Cushions should be regularly maintained for perfect use.
 - 2 people to install is recommend.
 - 2 people to lift the sofa if you want to move it, do not push or pull directly
 - You can assemble it with out packaging tools or home electric drill, as shown below, Electric Drill tool is not included.
- Electric drill will improve your assembling efficiency.
You can use it if you have this tool, DO NOT overtight to prevent from damaging screws and slats/boards.

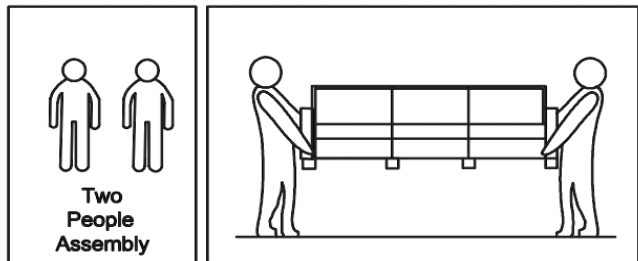
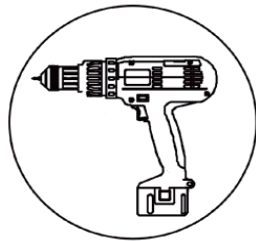

Components:

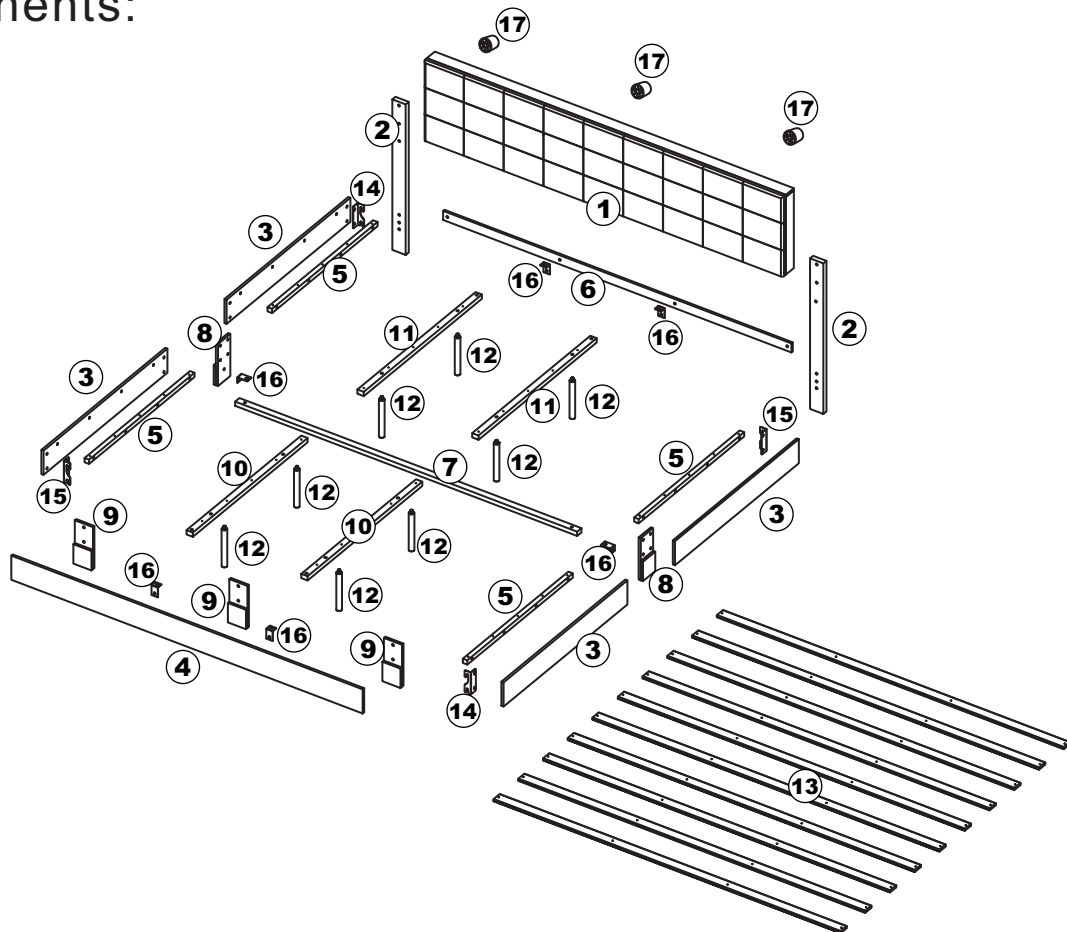

NOTE: Please do not completely tighten all the hardware until the entire assembly is complete!

ASSEMBLY TOOLS REQUIRED

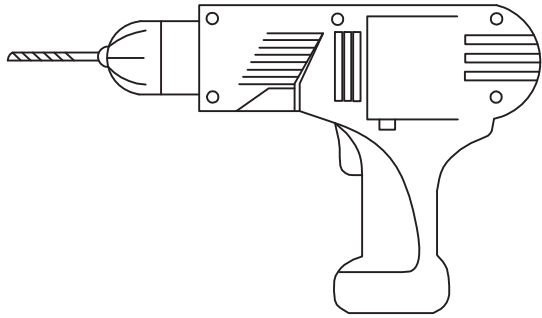

Electric Drill
(Not provide)



PH2



H5

Bit
(Include in hardware bag)

Electric Drill tool is not included.
Electric drill will improve your assembling efficiency.
You can use it if you have this tool,
DO NOT over drill to prevent from damaging screws and boards.

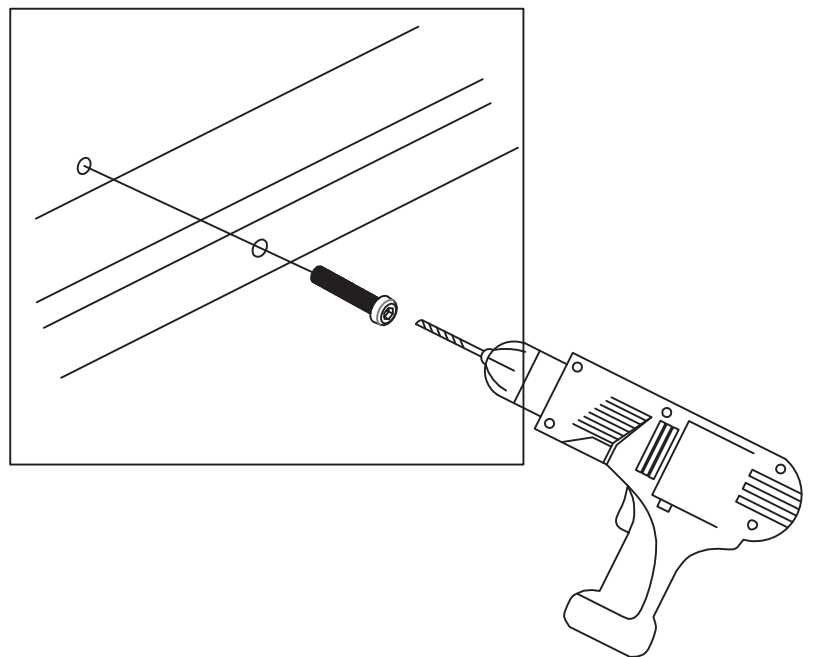
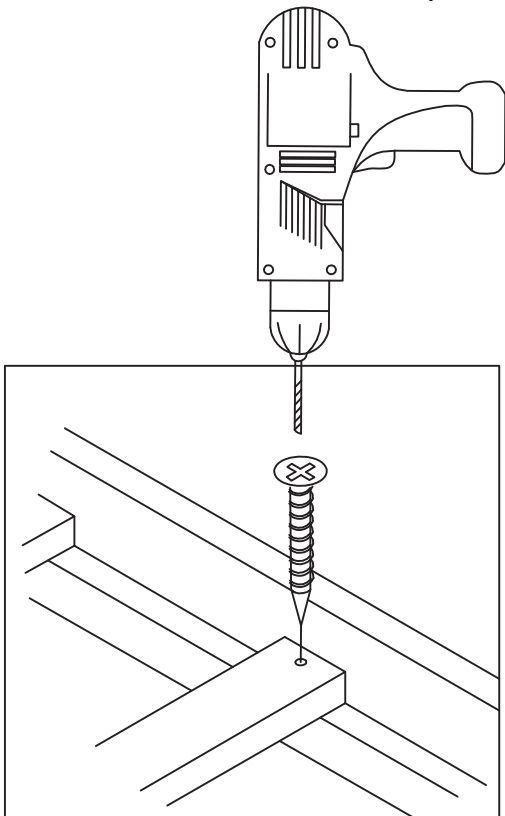

HARDWARE

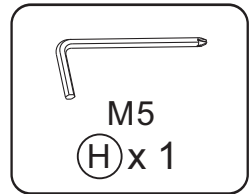
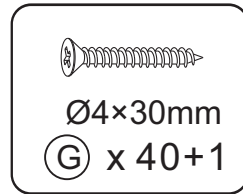
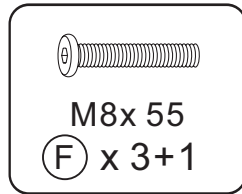
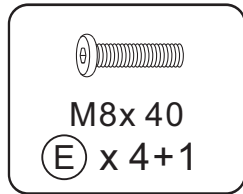
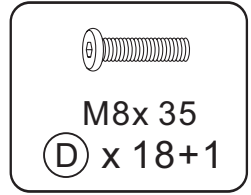
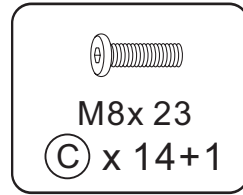
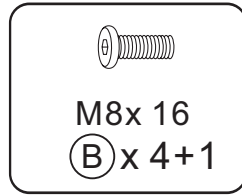
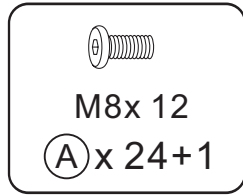

Step 1

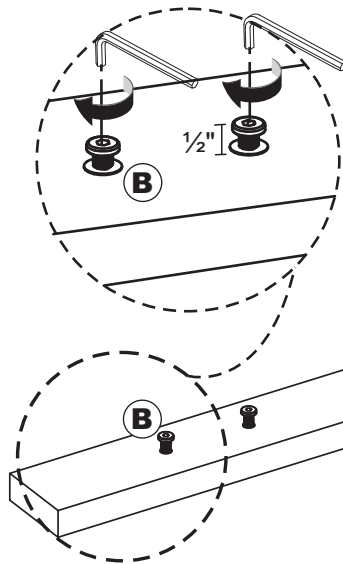
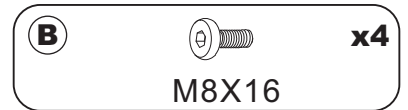

Tighten all the screws to the length shown in the figure.
Ziehen Sie alle Schrauben auf die in der Abbildung gezeigte Länge an

x2

Step 2

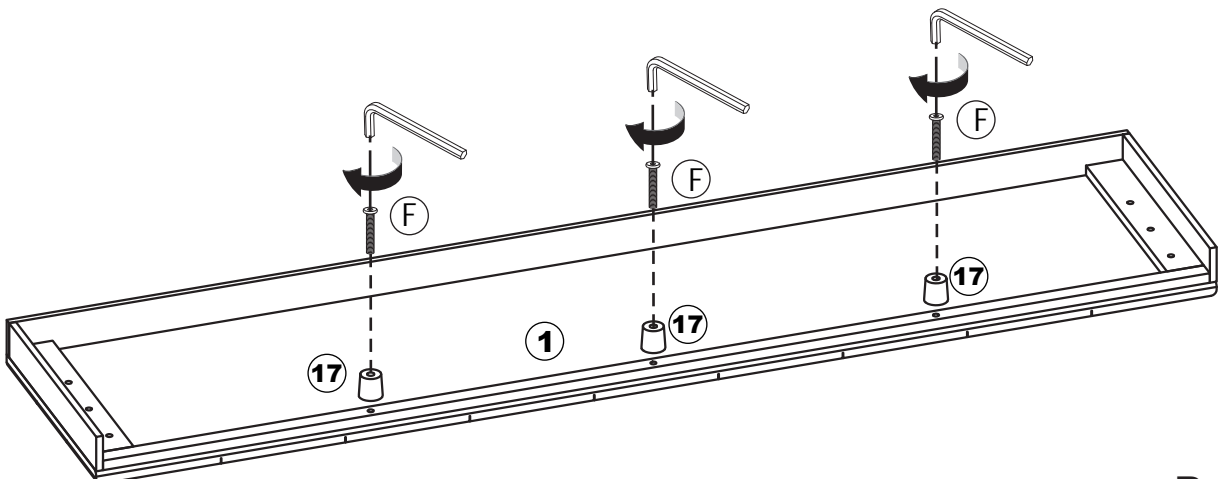
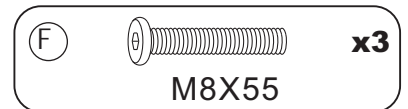

Step 3

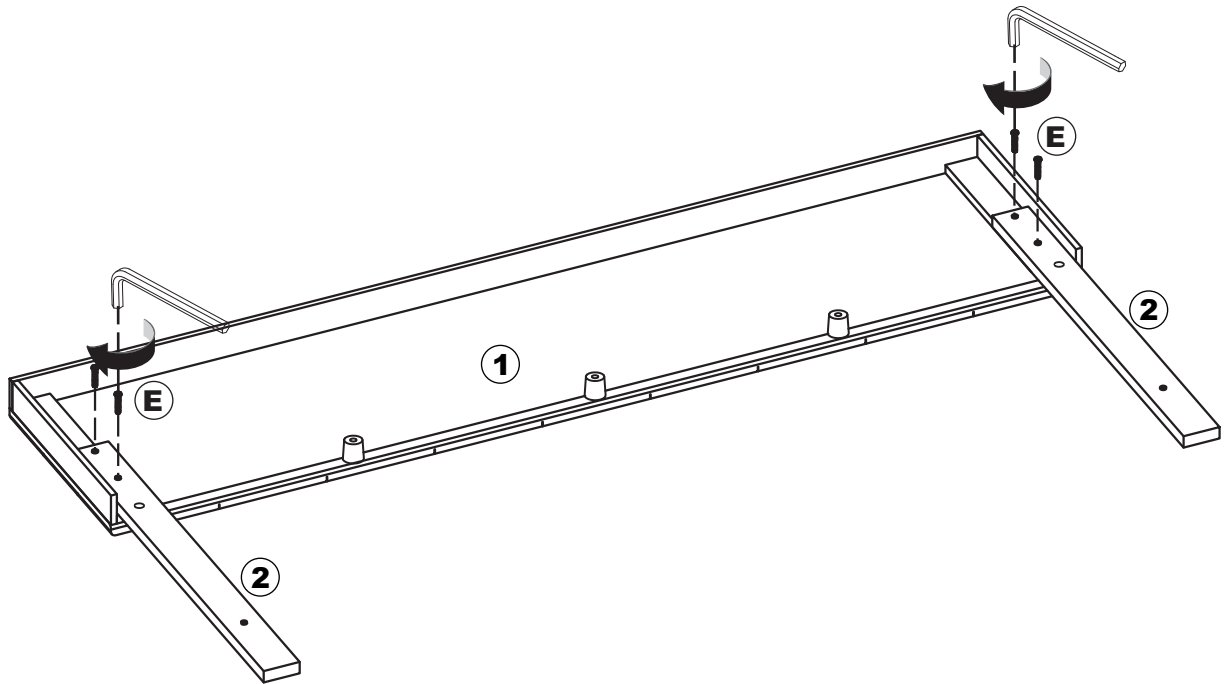
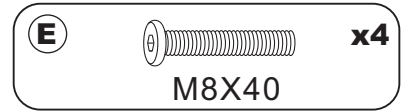

Step 4

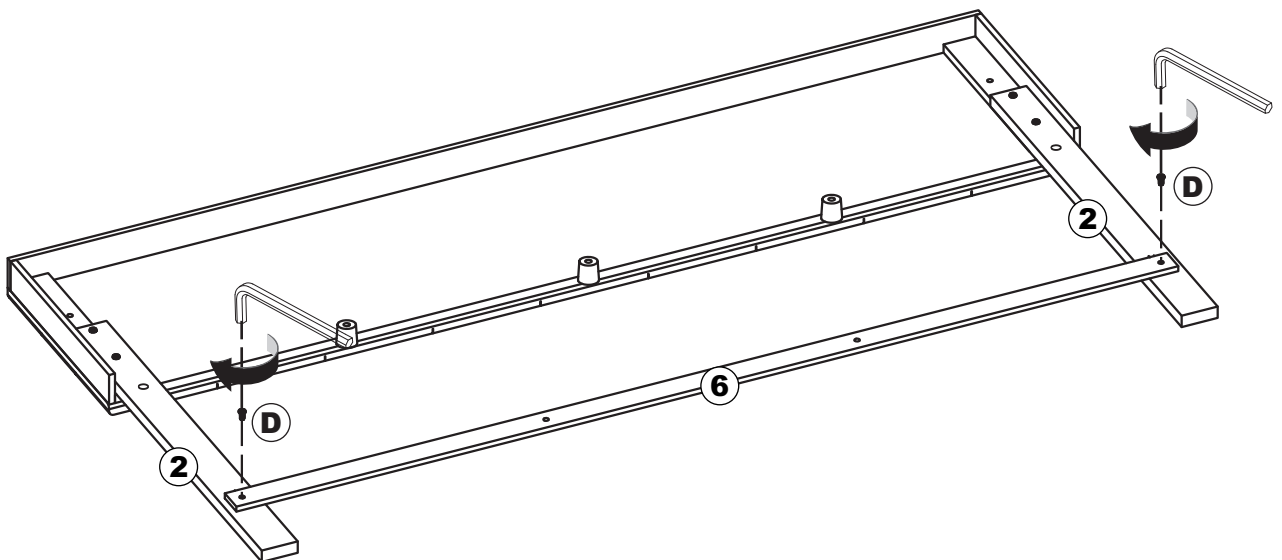
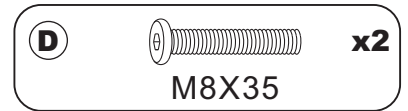

Step 5

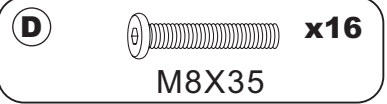
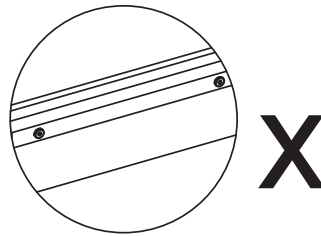
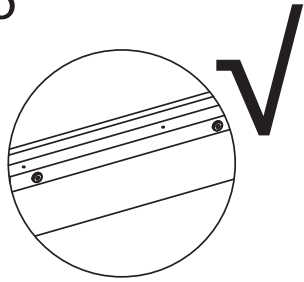

Please note that this lead hole is correct on top during installation
Bitte beachten Sie, dass dieses Bleiloch oben während der Installation korrigieren

Please note during installation that this lead hole facing downwards is incorrect

Bitte beachten Sie bei der Installation, dass dieses Bleiloch nach unten gerichtet ist falsch

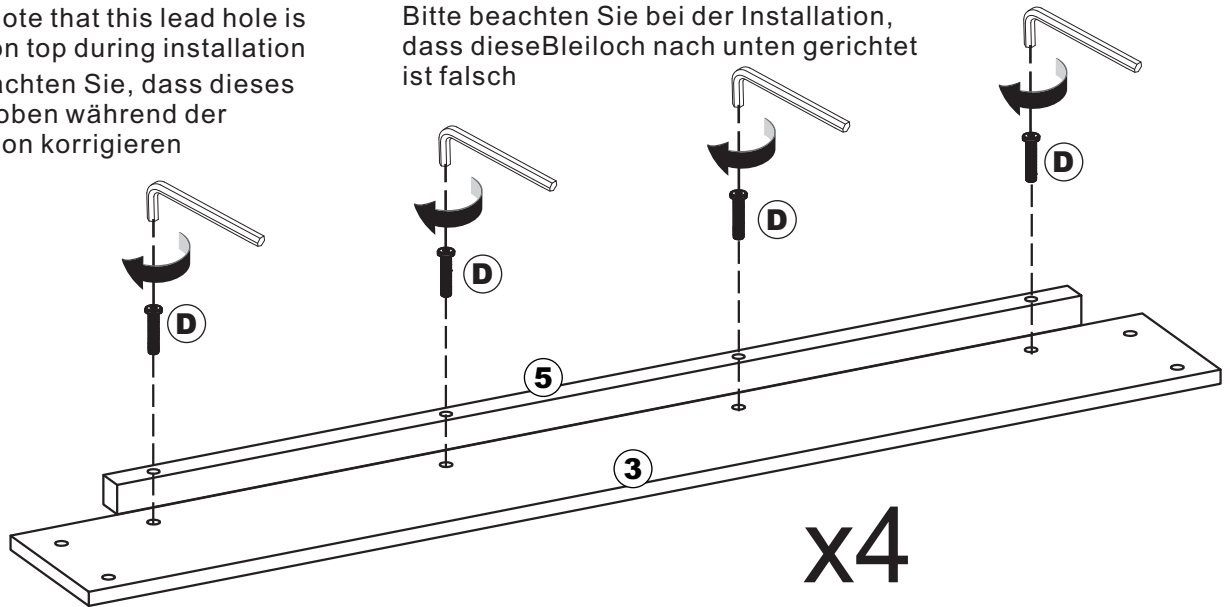

Step 6



x2

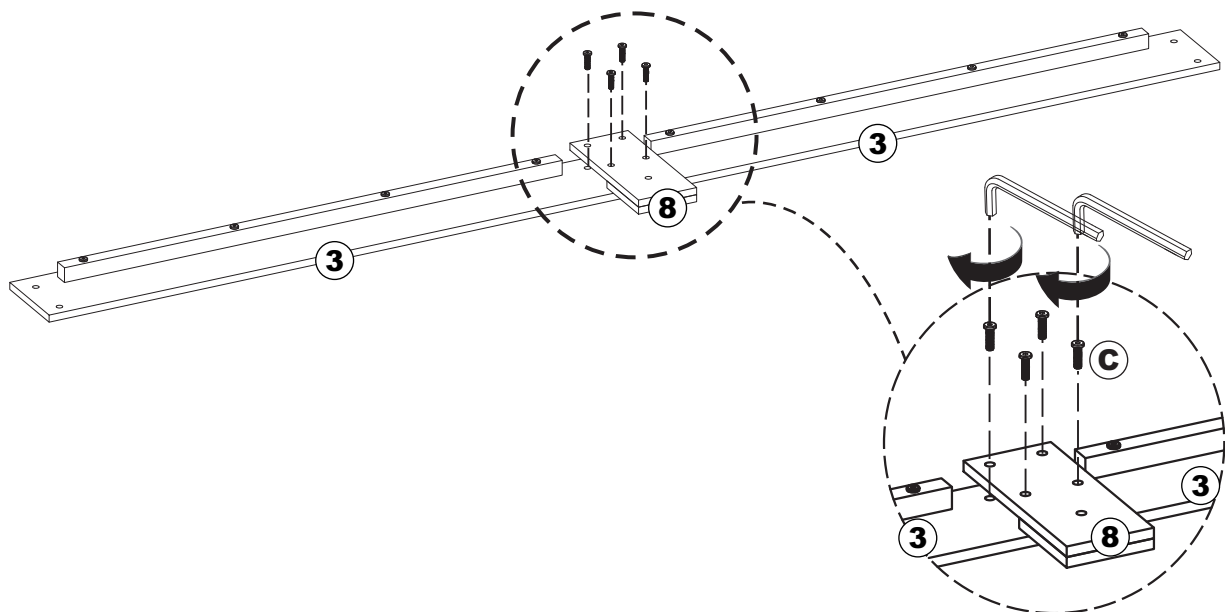

Step 7

A  **x8**
M8X12

x2

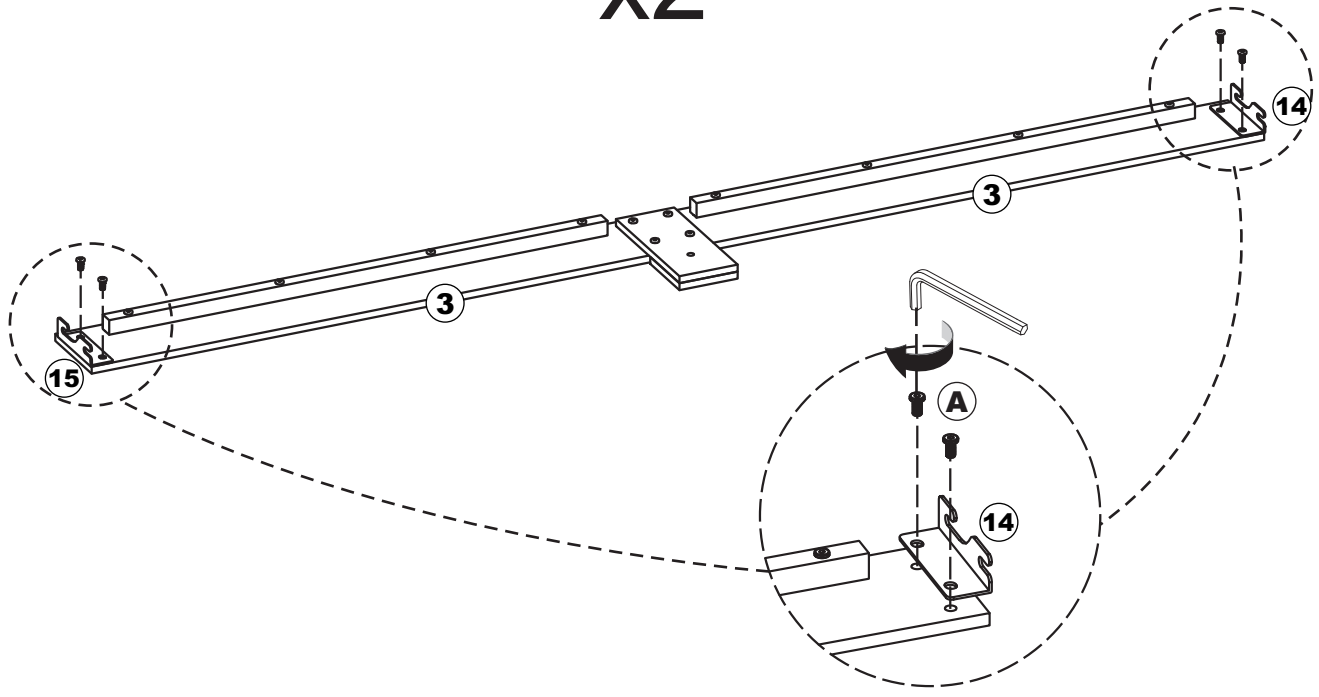

Step 8

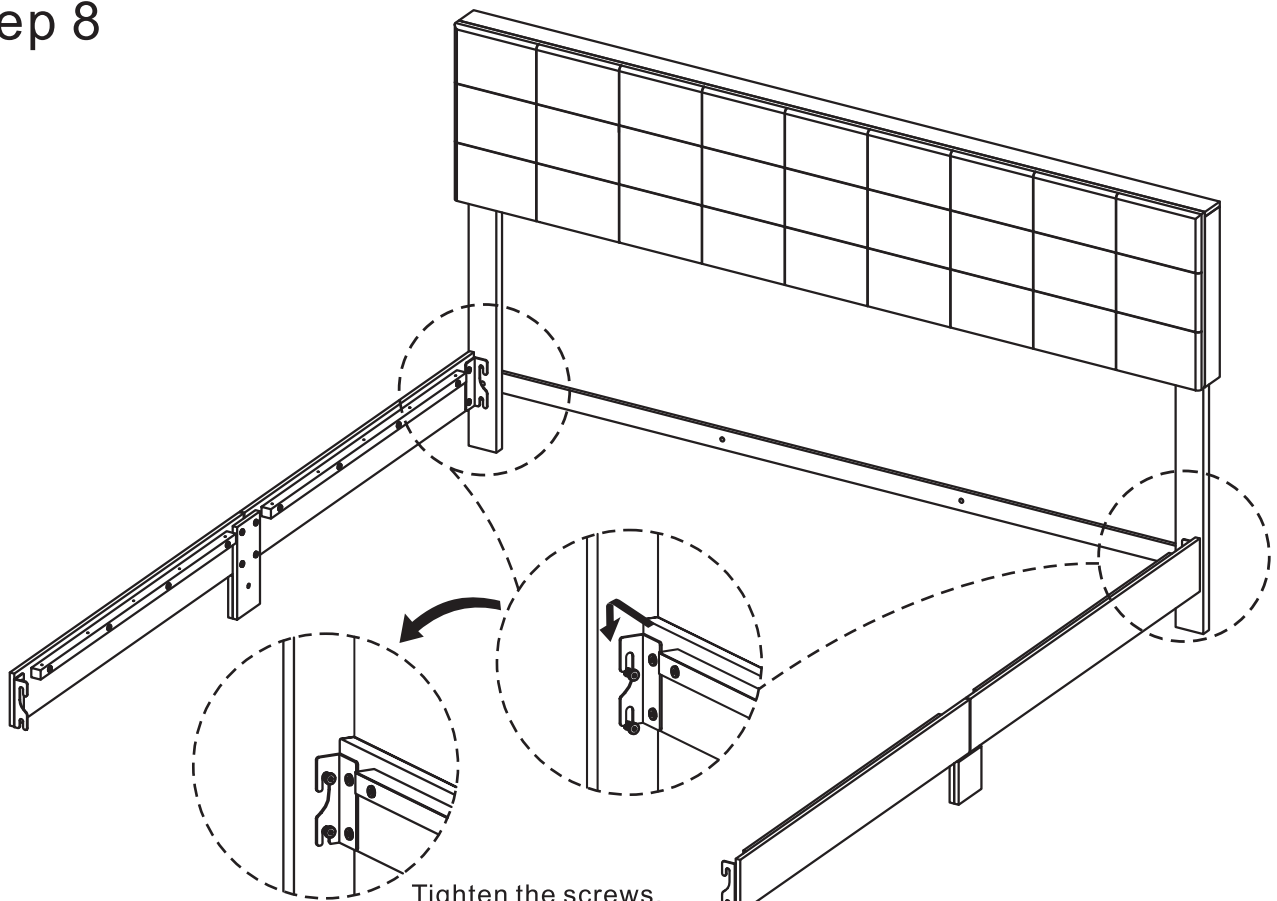

Tighten the screws.
Ziehen Sie die Schrauben an.

Step 9

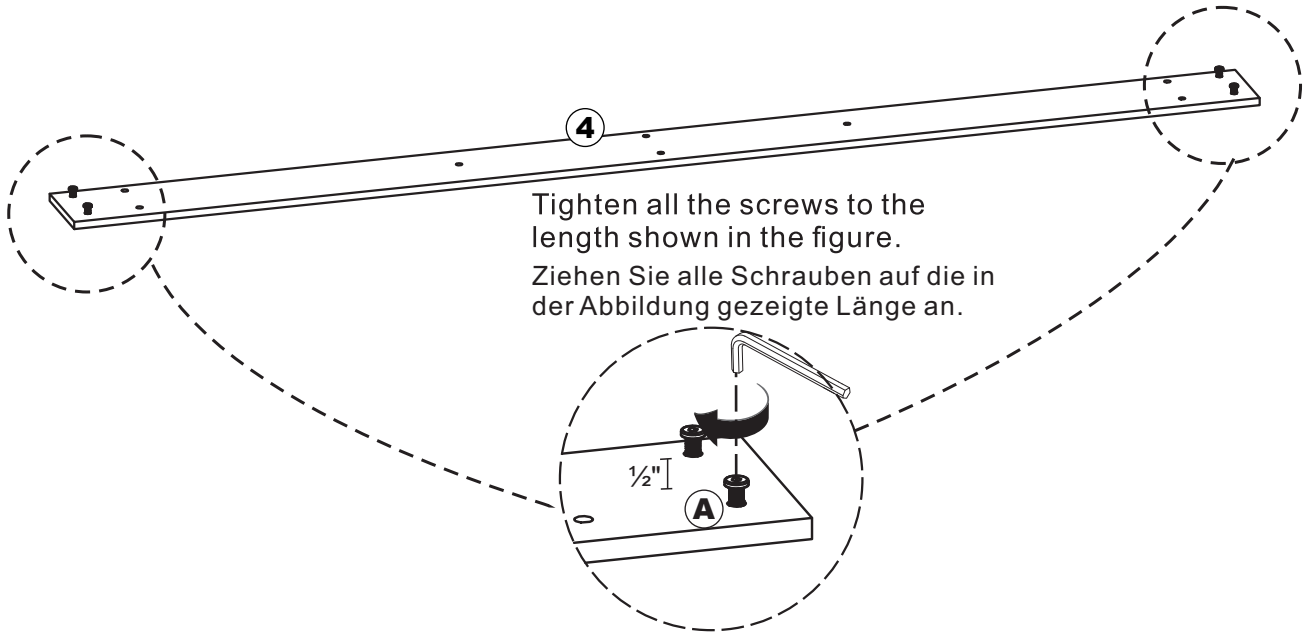

Step 10

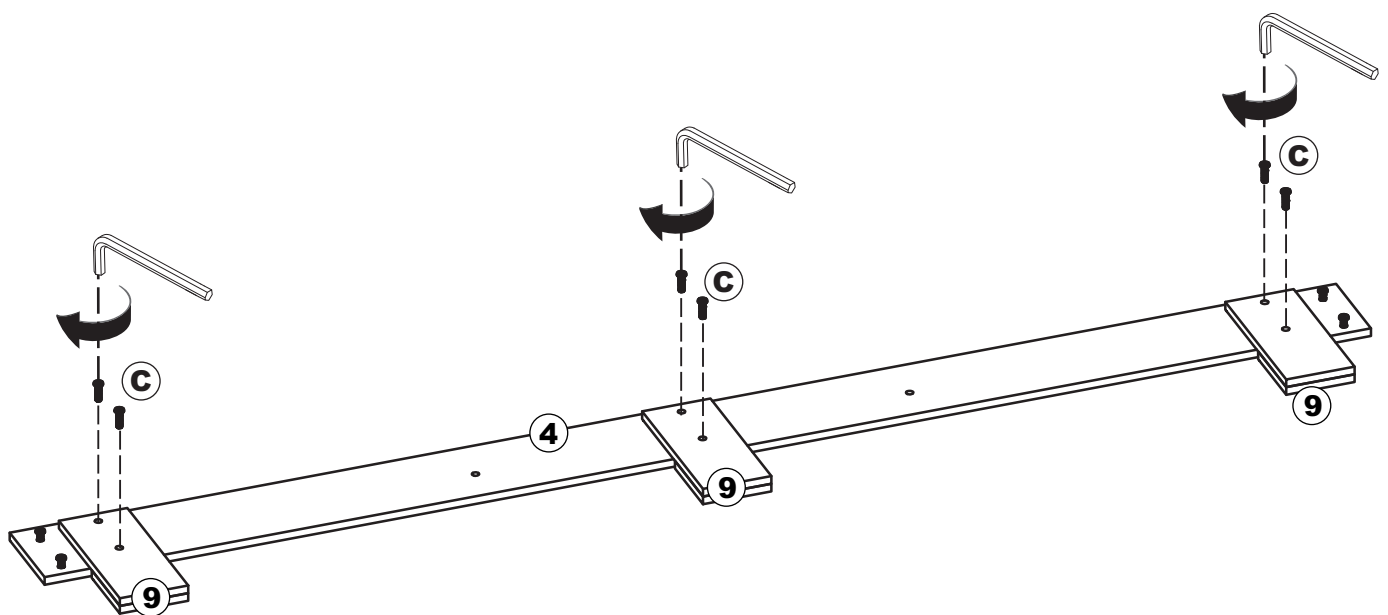

Step 11

Tighten the screws.
Ziehen Sie die Schrauben an.

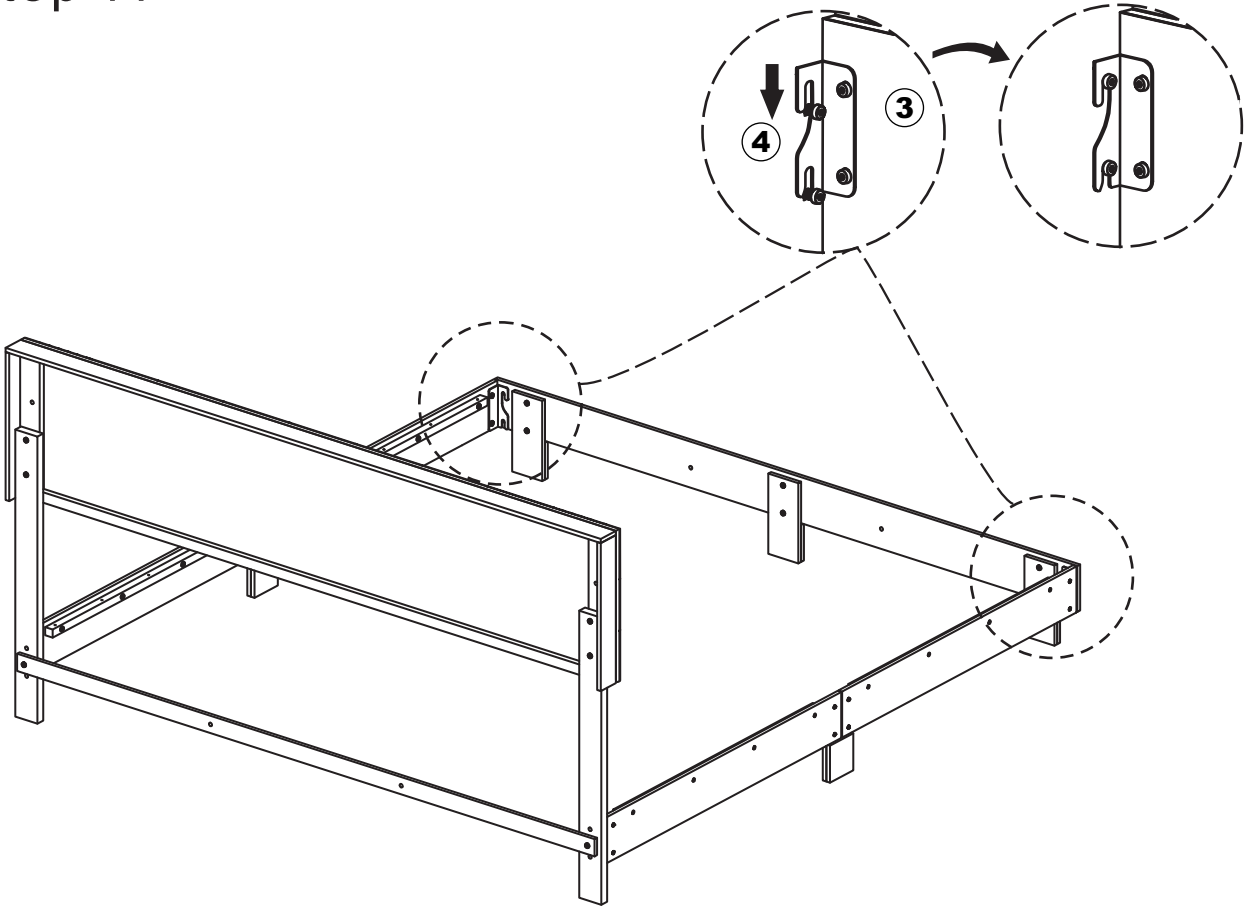

Step 12

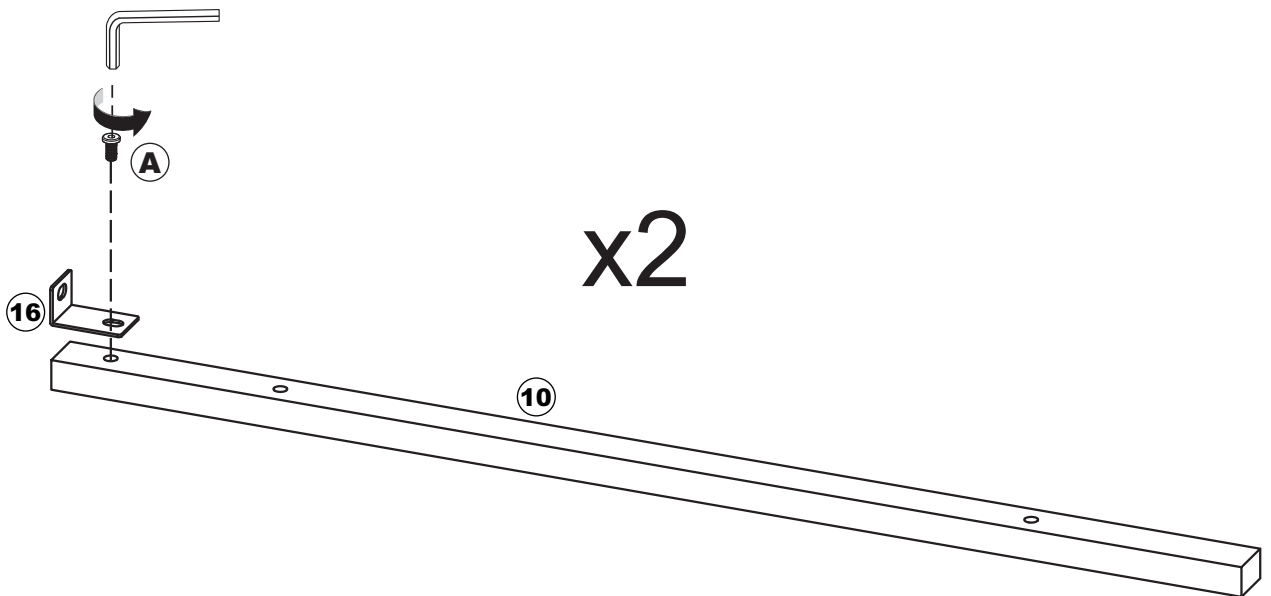
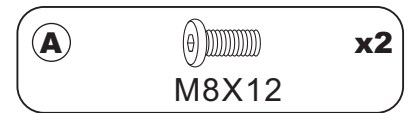

Step 13

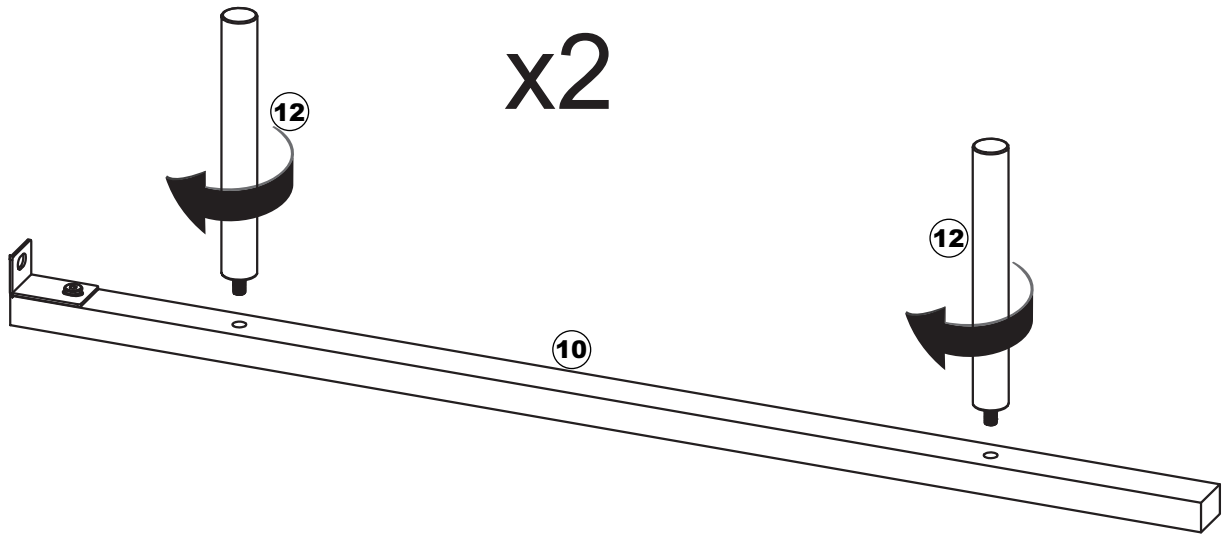

Step 14

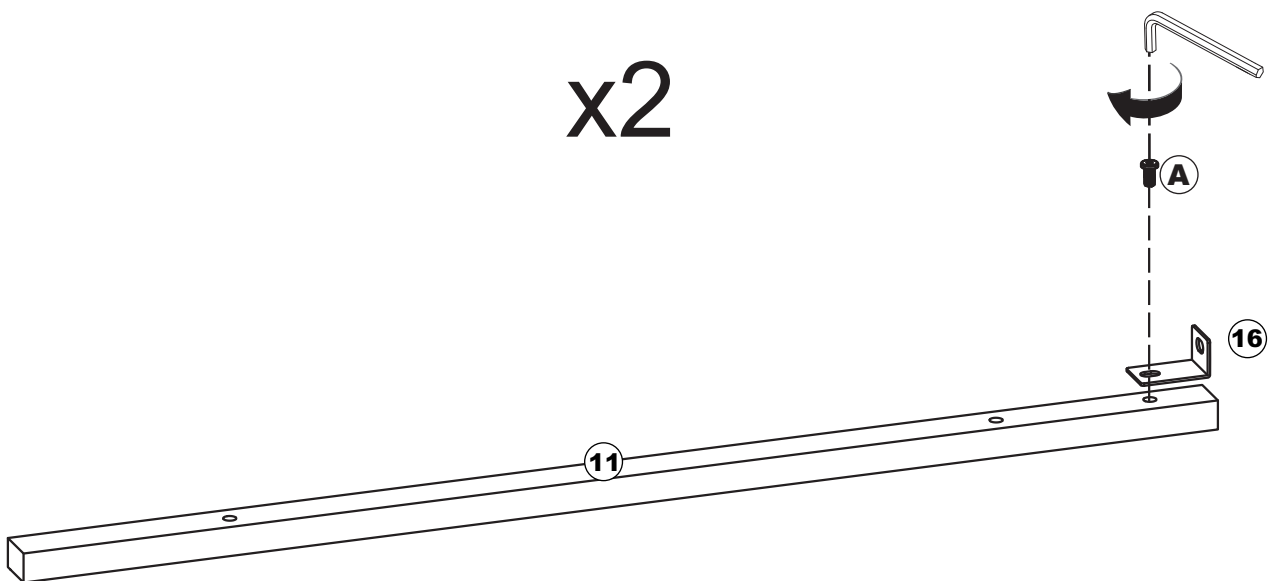
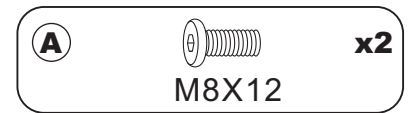

Step 15

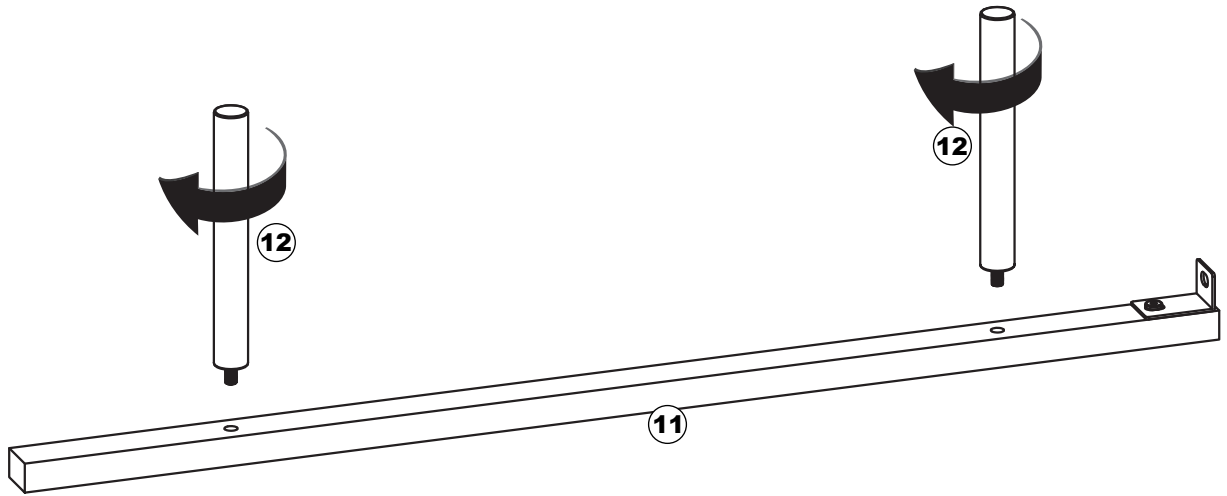

Step 16

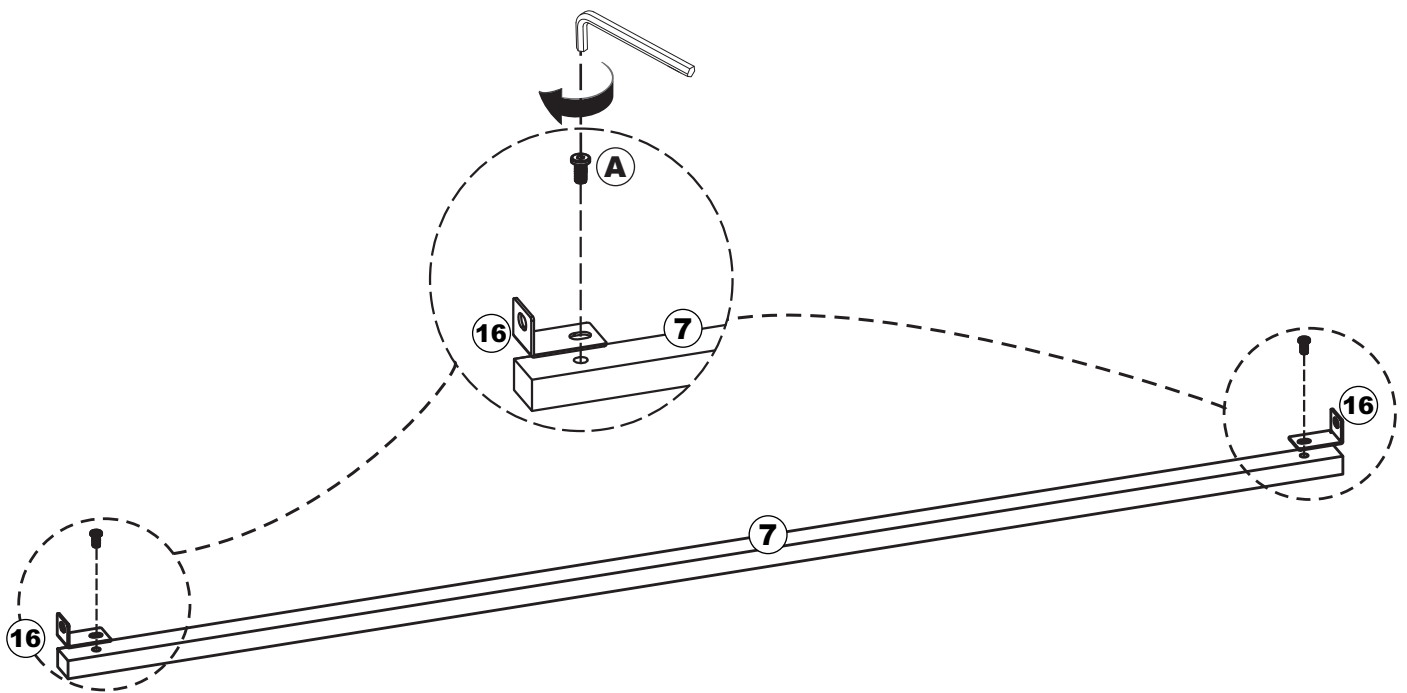
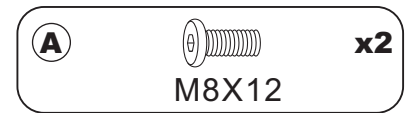

Step 17

A  **x2**
M8X12

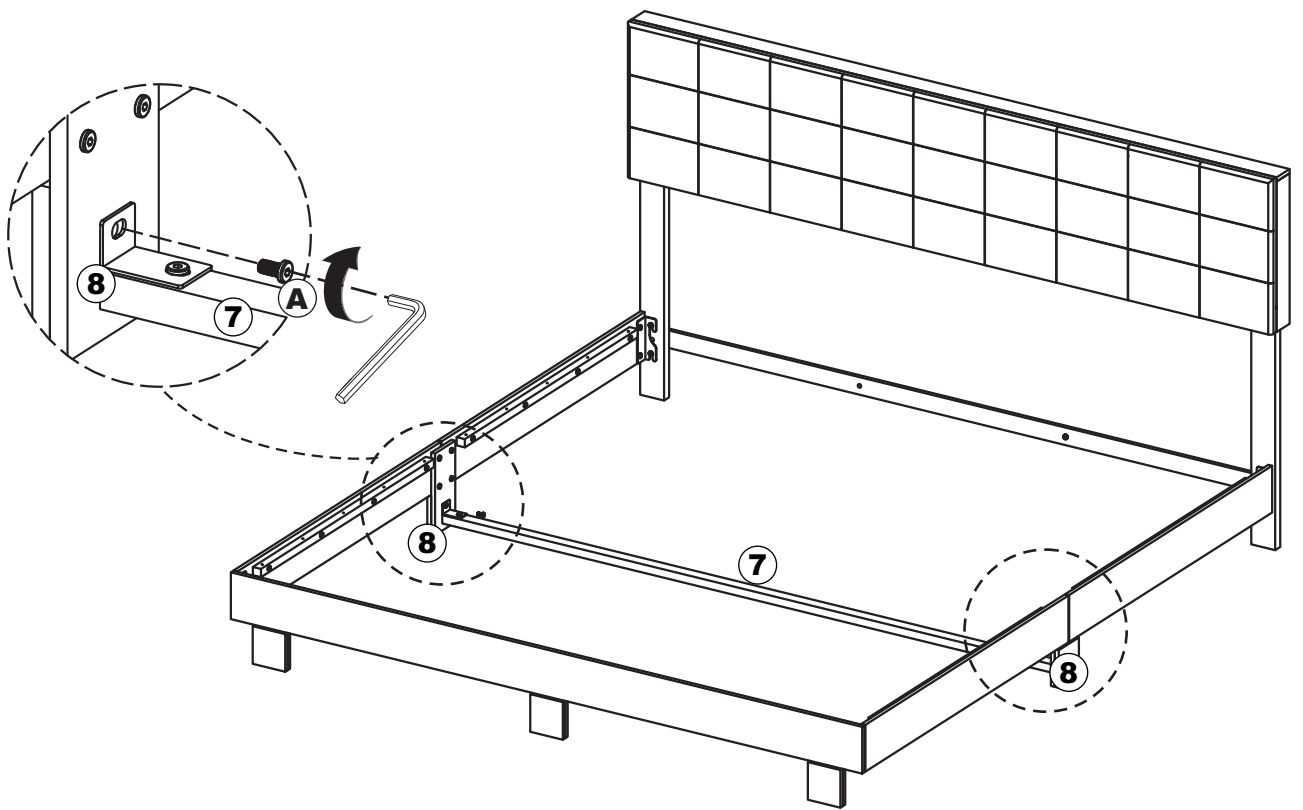

Step 18

A  **x4**
M8X12

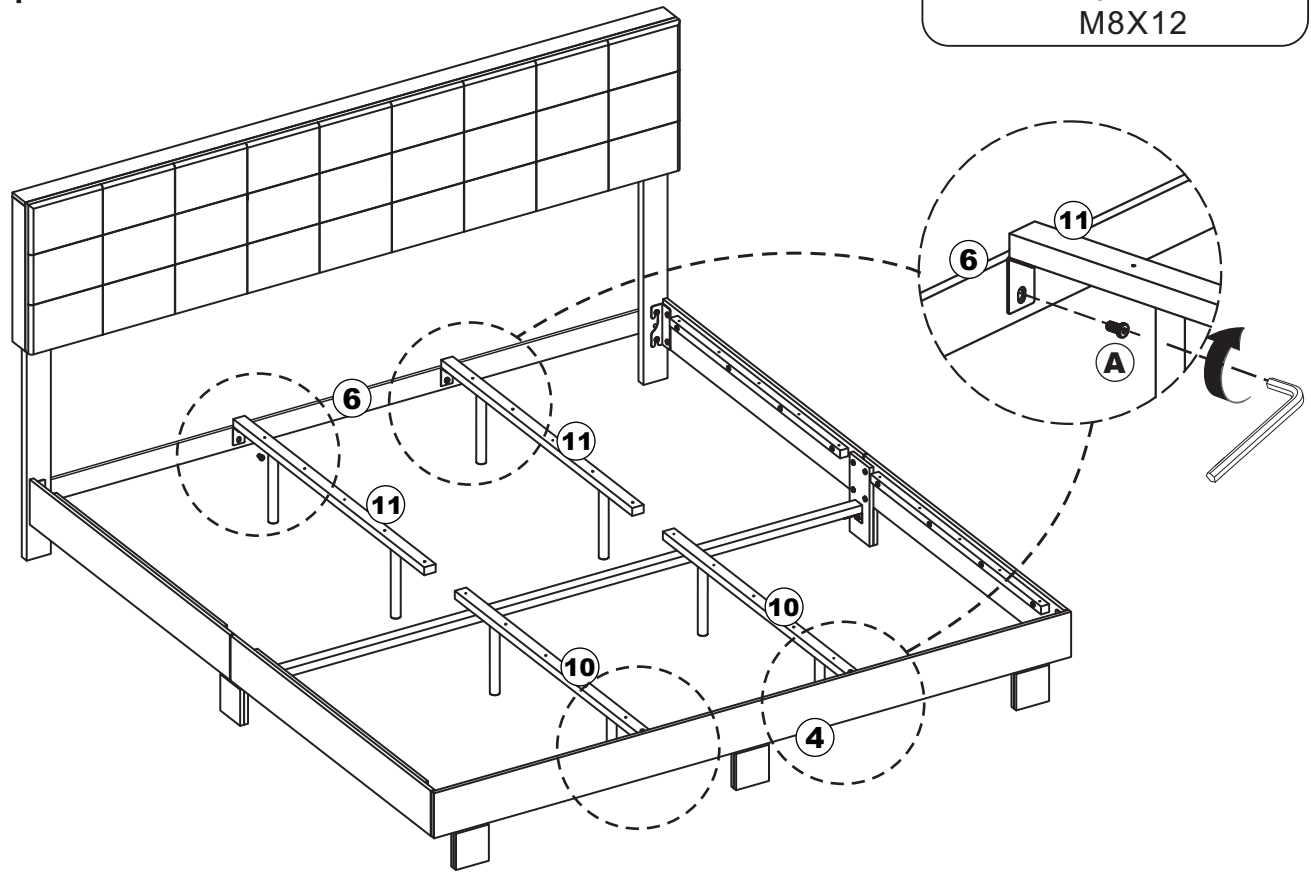

Step 19

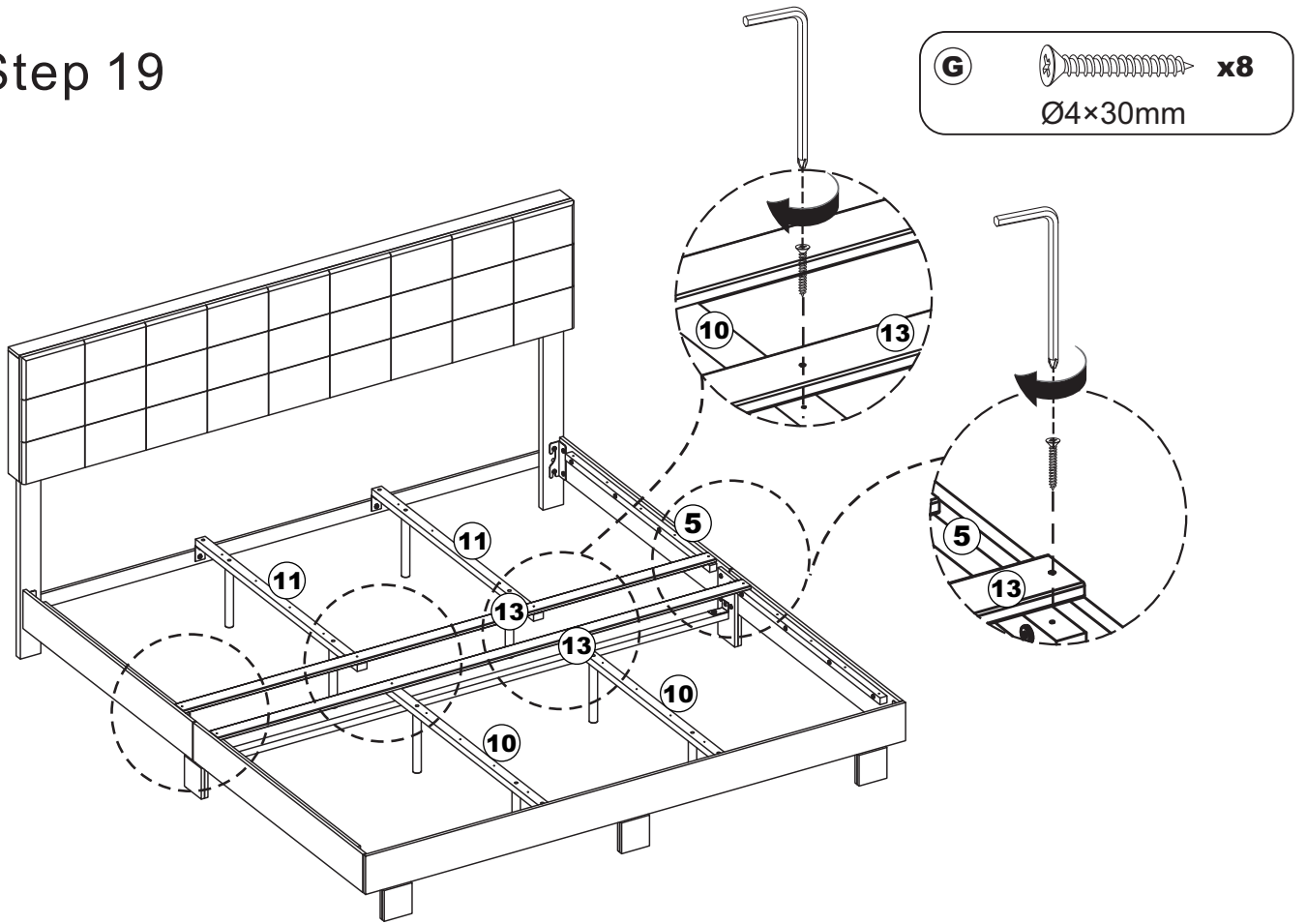

Step 20

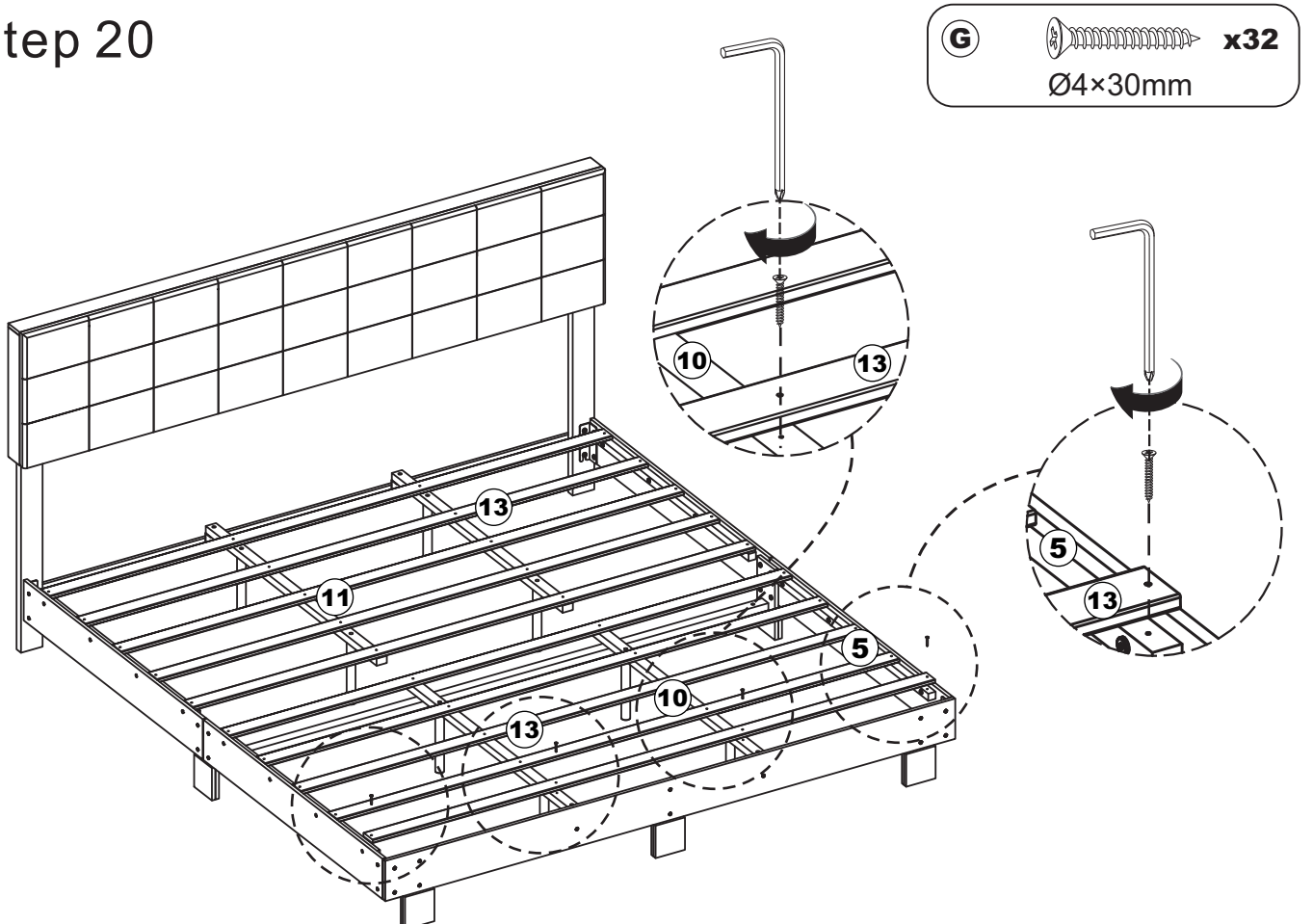

Step 21

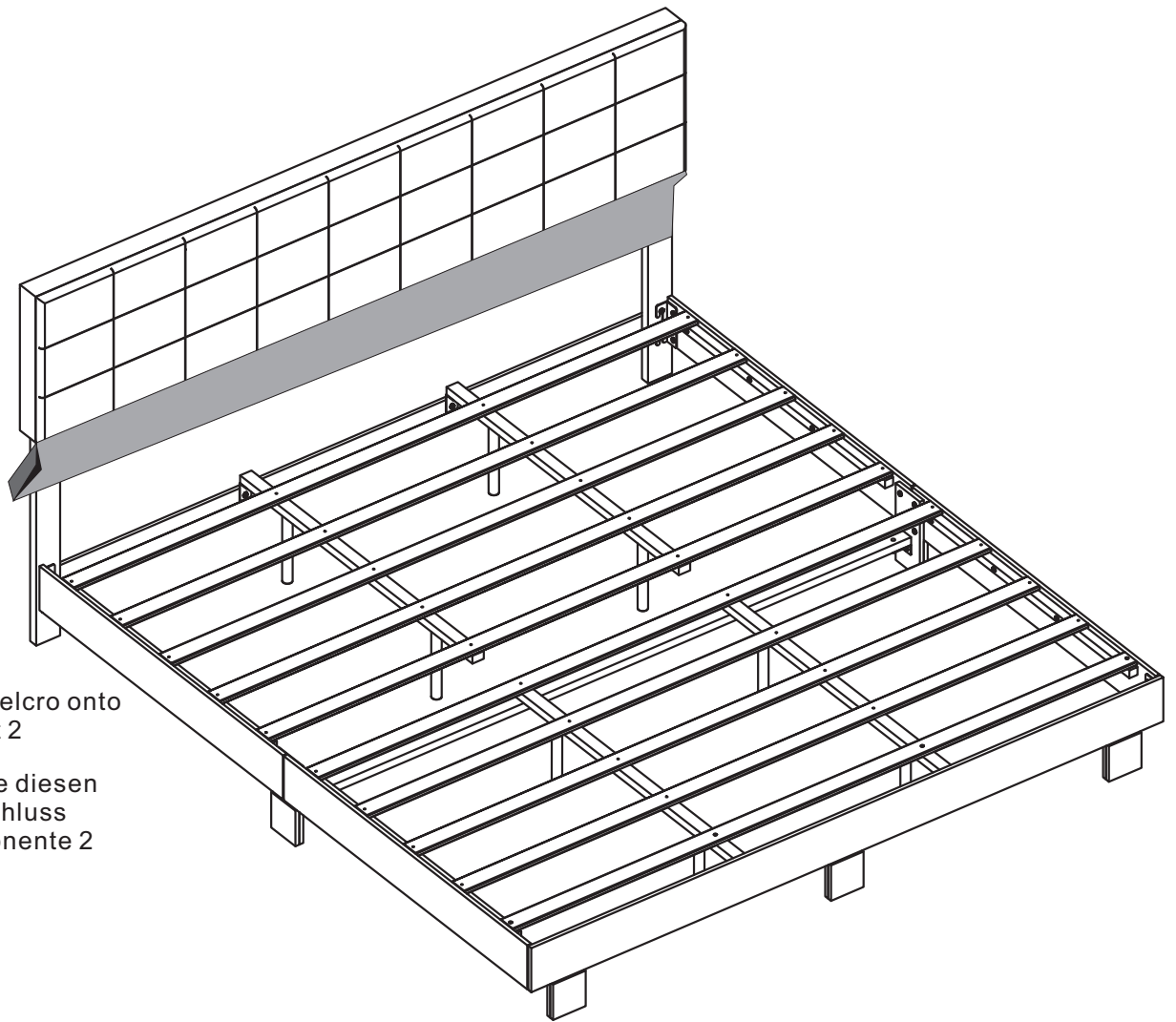

Stick this Velcro onto
component 2

Kleben Sie diesen
Klettverschluss
aufKomponente 2