

Climate 5000 Series - Gen 4

18K BTU Single Zone Regular System

4-Way Cassette IDU

Engineering
 Submittal
 Sheet



BOSCH

Overview and Project Information



Project name	
Location	
Architect	
Engineer	
General contractor	
Reference #	

18K Btu Single Zone Regular System - 4-Way Cassette IDU

Indoor part number	8-733-962-718	
Indoor model number	BMS500-AAU018-1AHCXD	
Outdoor part number	8-733962-686	
Outdoor model number	BMS500-AAS018-1CSXRD	
Efficiency Data AHRI 210/240 2023		
SEER2	20.7	
EER2	12.5	
HSPF2 Region IV	11.4	
HSPF2 Region V	8.5	
COP(47F)	3.36	
COP (5F)	2.20	
Performance Data AHRI 210/240 2023		
Cooling	Capacity Range	5300~17800
	Rated Capacity	16800
	Current	6.1
	Input Power	1344
Heating	Capacity Range	7100~21500
	Rated Capacity (47F)	18000
	Rated Capacity (5F)	12800
	Current	7.2
	Input Power	1570
Electrical Data		
Power supply (V / Ø / Hz)	208-230 / 1 / 60	
Min. circuit ampacity indoor/outdoor (A)	3.0 / 18.0	
Max. fuse indoor/outdoor (A)	15.0 / 20.0	
Compressor Data		
Type:	Rotary	
Refrigerant oil /oil charge (ml)	VG74 / 440	
Input (W)	1090	
Rated current (RLA/A)	7.2	
Piping		
Refrigerant precharge (oz/kg)	47.97 / 1.36	
Length for precharge (ft/m)	24.6 / 7.5	
Liquid side (in/mm)	1/4" / Ø6.35	
Gas side (in/mm)	1/2" / Ø12.7	
Additional charge per ft (oz/g)	0.16 / 4.54	
Max. refrigerant pipe length (ft/m)	98.40 / 30	
Max. difference in height (ft/m)	65.60 / 20	

Operation Range

ODU	Cooling (°F / °C)	-13~122 / -25~50
	Heating (°F / °C)	-13~75 / -25~24
IDU	Cooling (°F / °C)	60~90 / 16~32
	Heating (°F / °C)	32~86 / 0~30

System Data

Refrigerant type		R454B
Design pressure (PSIG)		550 / 340
Dehumidification (pts/hr)		4.33
IDU	Fan motor model	ZKFN-45-8-2
	Fan motor qty (ea)	1
	Fan motor input (W)	50.0
	Fan speed (RPM)	800 / 750 / 700
	Air flow, Turbo / H / M / L / Si (CFM)	447.3 / 388.5 / 317.8 / 194.2 / 147.2
	Approx. Air Throw Range ft (m)	9.8 / 3
	Noise level, Turbo / H / M / L / Si (dB(A))	48 / 44.0 / 41.0 / 28.5 / 24.5
	Net weight (lbs / kg)	35.27 / 16.0
	Gross weight (lbs / kg)	41.89 / 19.0
	Panel net weight (lbs / kg)	5.95 / 2.7
Gross panel weight (lbs / kg)	9.48 / 4.3	
Drain pipe diameter (mm)		ODØ25mm
ODU	Fan motor model	ZKFN-80-10-1L
	Fan motor qty (ea)	1
	Fan motor input (W)	161.0
	Fan motor speed (RPM)	780 / 700 / 550
	Air flow, Max (CFM)	1765.8
	Noise level, Max (dB(A))	57.5
	Net weight (lbs / kg)	92.59 / 42.0
Gross weight (lbs / kg)	100.31 / 45.5	
Accessories		
BMS-CCG-XXD (8733962708)	Decorative Grille - 9K ~ 18K	
BMS-WT2-XXD (8733962707)	Wired Wall Thermostat	
BMS-DRY-XXD (8733969263)	24V Interface	
BMS-PK2-7X1 (8733951011)	25ft Lineset	
Standard Parts		
8-733-969-065	Remote Control	

Climate 5000 Series - Gen 4

18K Btu Single Zone Regular System - 4-Way Cassette IDU



BOSCH

Indoor Unit Dimensions and Connections

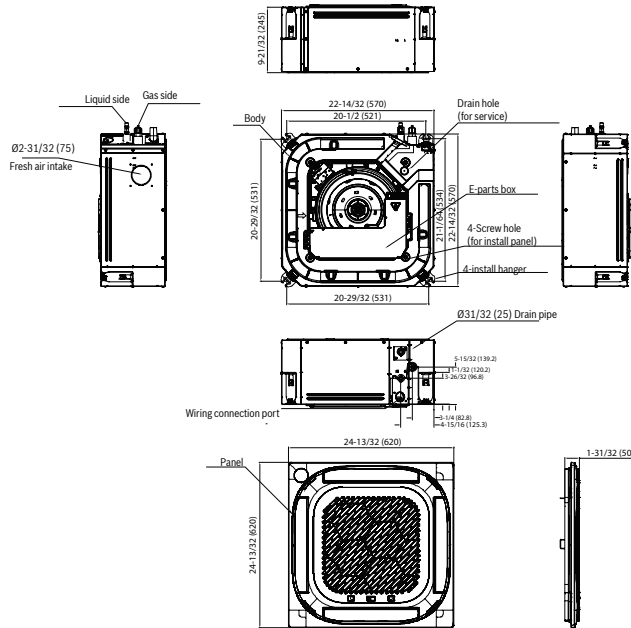

Model	W (in)	D (in)	H (in)
BMS500-AAU018-1AHCXD	22.44	22.44	9.65

Outdoor Unit Dimensions and Connections

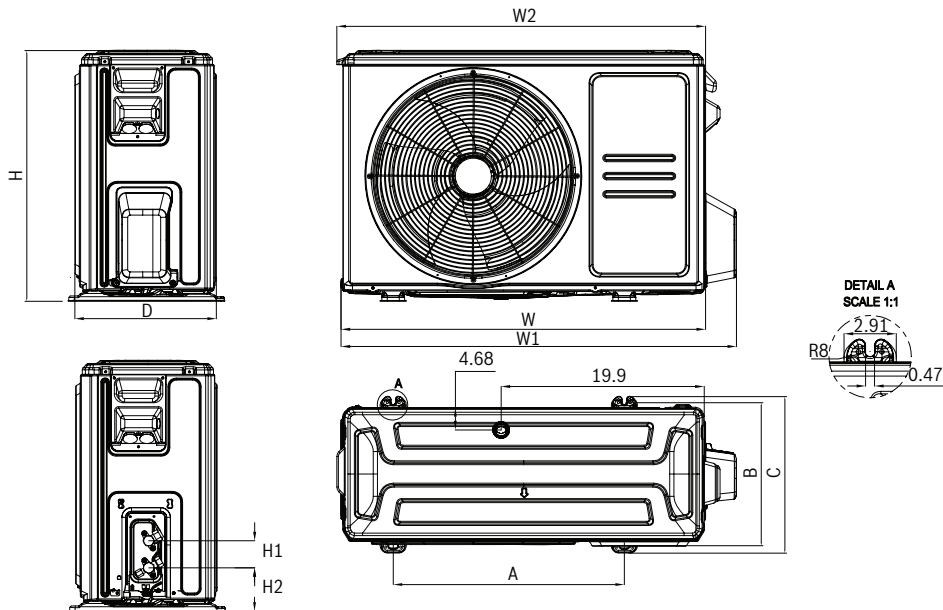

Model	W (in)	D (in)	H (in)	W1 (in)	W2 (in)	A (in)	B (in)	C (in)	H1 (in)	H2 (in)
BMS500-AAS018-1CSXRD	35	13.46	26.5	37.6	35.24	26.1	13.7	14.96	2.36	4.25