

ASSEMBLY INSTRUCTION

RATTAN DINING SET

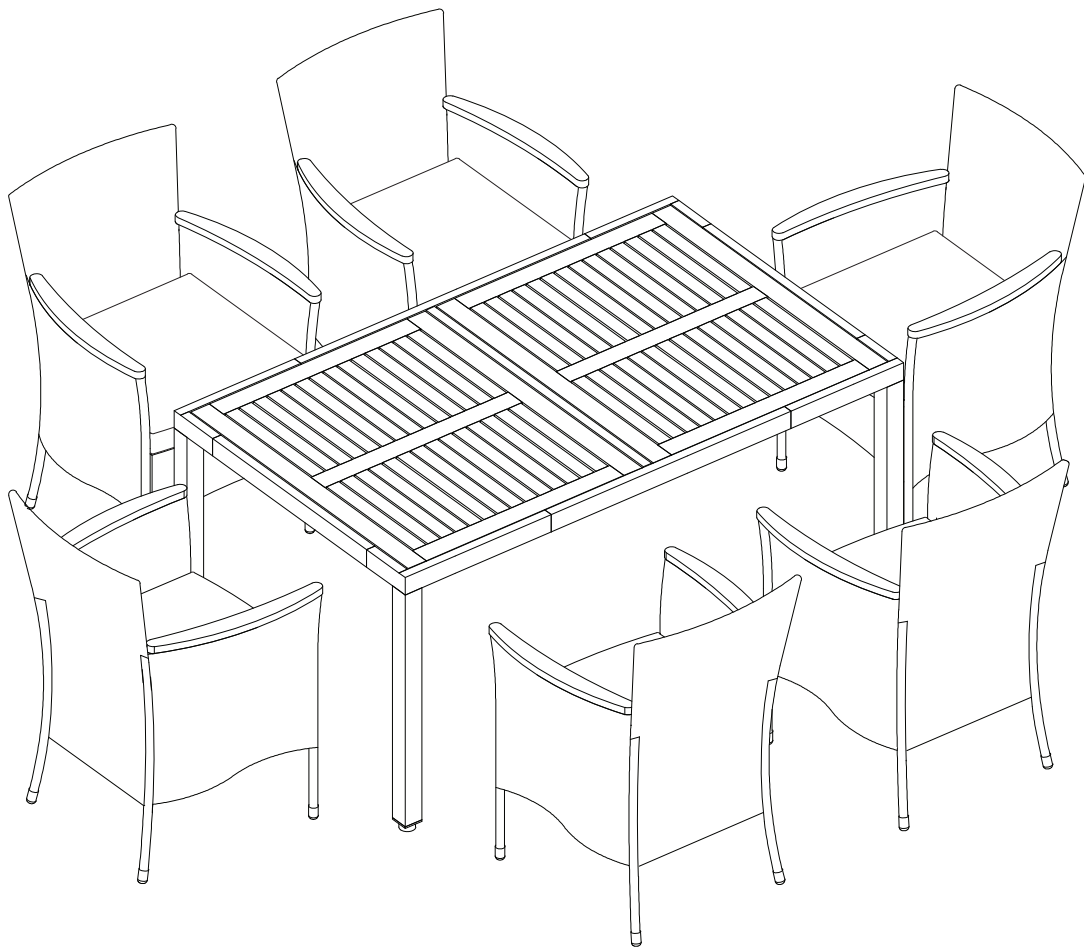

WF212546AAA
WF212547AAA
WF212548AAA

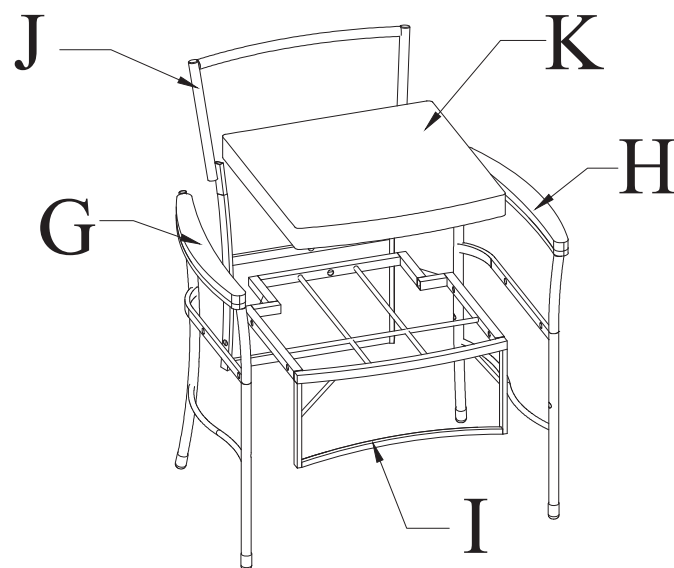
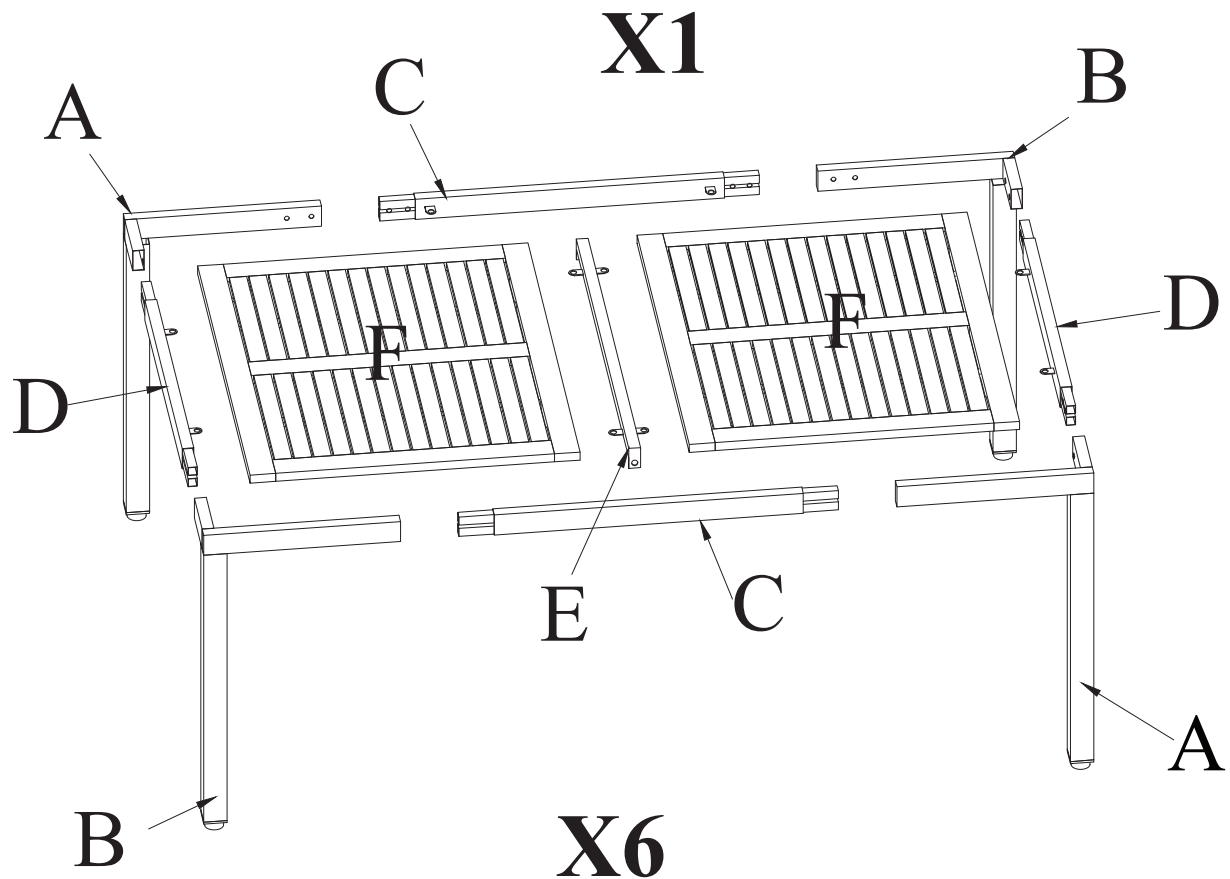

Notice:

1. 50% Tighten before fixing all screws, Allen wrench is recommended instead of an electric drill.
2. Place the item on a flat ground to adjust and make sure it remains stable
3. Tighten up all screws with tools gradually.
4. If the screws are not aligned with holes during assembly, please loosen all the other screws to 50% and continue the assembly process.
5. If the item is not stable, please loosen all the screws, adjust it on a flat ground and tighten up all screws again.
6. Note : If one or some screws are fully tightened during assembly, chances are the others will not be aligned with holes. In addition, all the holes are designed to be relatively larger to provide more space for the adjustment of the screws.

CARTON CONTENT:

WF212546AAA:

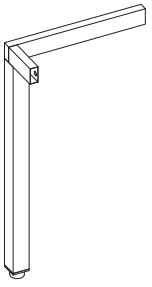

[A] x 2

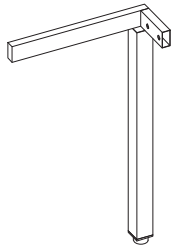

[B] x 2

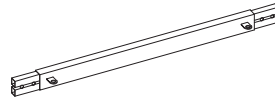

[C] x 2

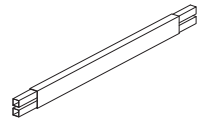

[D] x 2



[E] x 1

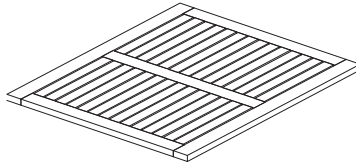

[F] x 2

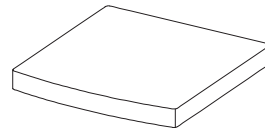

[K] x 6

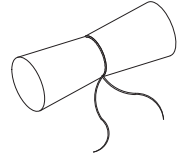

HARDWARE

WF212547AAA:

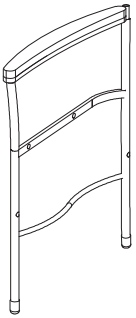

[G] x 3

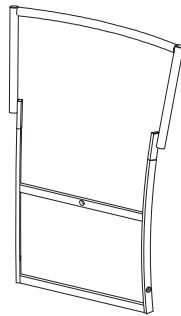

[J] x 3

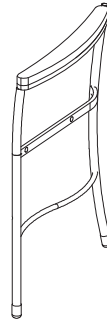

[H] x 3

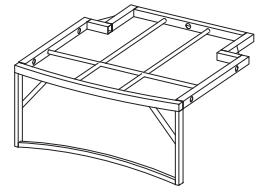

[I] x 3

WF212548AAA:

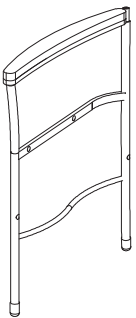

[G] x 3

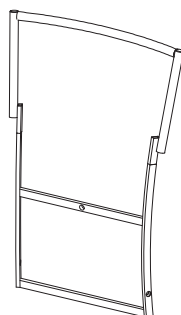

[J] x 3

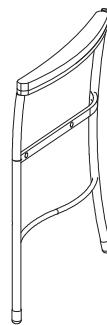

[H] x 3

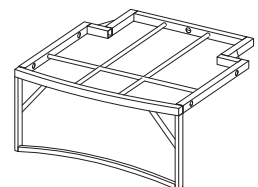



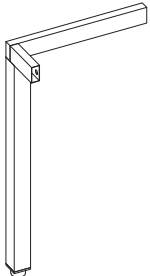
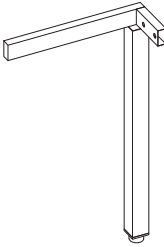
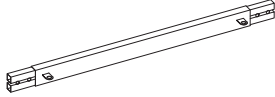
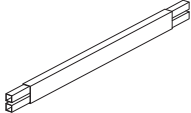
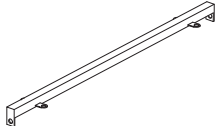
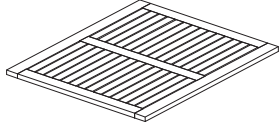
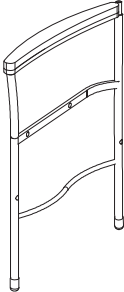
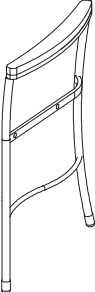
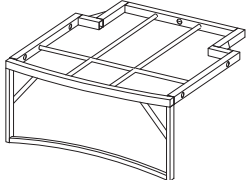
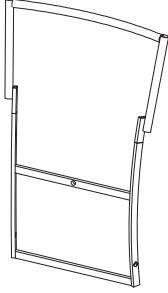
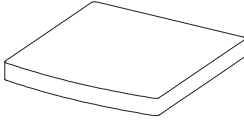

[I] x 3

PART LIST

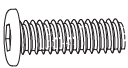
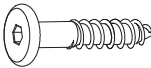
<p>A</p>  <p>Leg table 1 (2pcs)</p>	<p>B</p>  <p>Leg table 2 (2pcs)</p>	<p>C</p>  <p>Cross bar 1 (2pcs)</p>
<p>D</p>  <p>Cross bar 2 (2pcs)</p>	<p>E</p>  <p>Cross bar 3 (1pc)</p>	<p>F</p>  <p>Top table (2pcs)</p>
<p>G</p>  <p>Leg frame 1 (6pcs)</p>	<p>H</p>  <p>Leg frame 2 (6pcs)</p>	<p>I</p>  <p>Seat frame (6pcs)</p>
<p>J</p>  <p>Back frame (6pcs)</p>	<p>K</p>  <p>Cushion chair (6pcs)</p>	

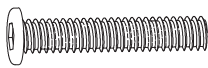
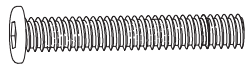
HARDWARE LIST

<p>1</p>  <p>Bolt M6x20 (18pcs + extra 2pcs)</p>	<p>2</p>  <p>Screw M6x15 (12pcs + extra 2pcs)</p>	<p>3</p>  <p>M6x1 Washers (72pcs + extra 5pcs)</p>	<p>4</p>  <p>Bolt M6x30 (24pcs + extra 2pcs)</p>	<p>5</p>  <p>Bolt M6x40 (30pcs + extra 3pcs)</p>	<p>6</p>  <p>Allen key M4 (2pcs)</p>
---	---	--	---	--	--

STEP 1

- [A] x 2pcs
- [B] x 2pcs
- [C] x 2pcs
- [1] x 8pcs
- [3] x 8pcs

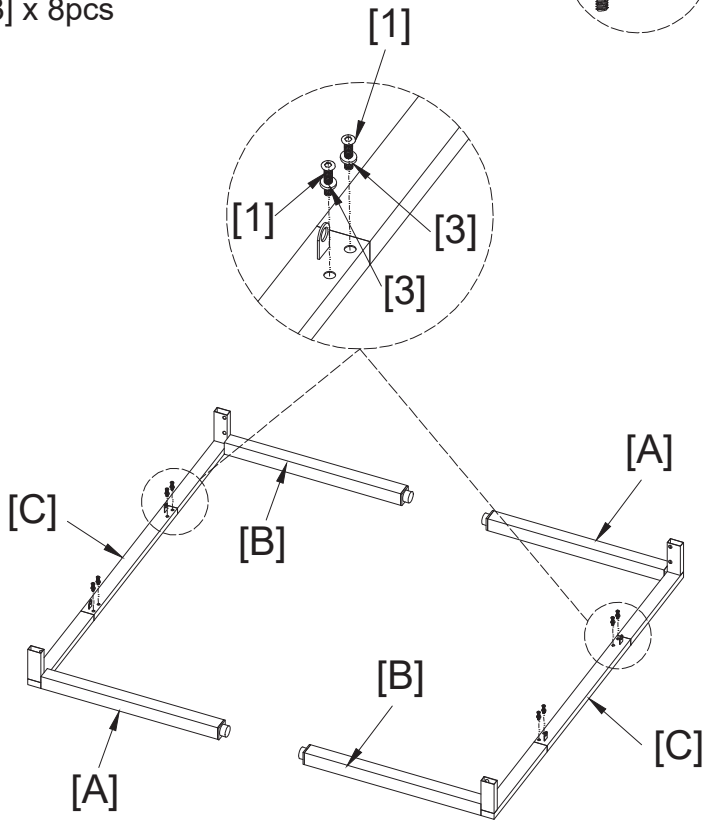

STEP 2

- [D] x 2pcs
- [E] x 1pc
- [1] x 5pcs
- [3] x 5pcs

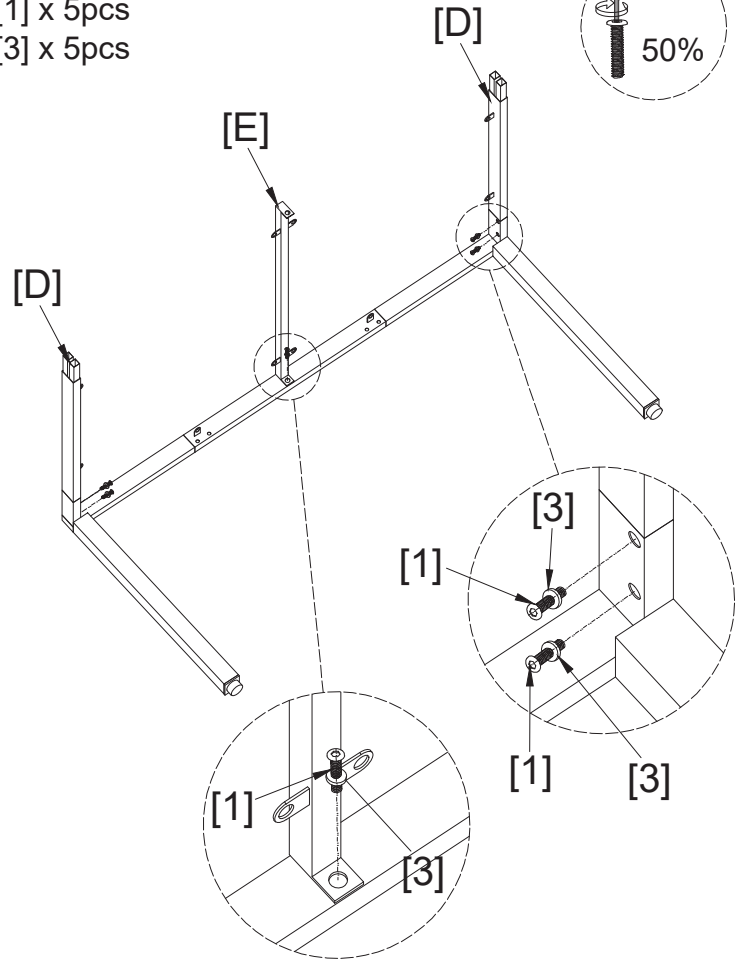

STEP 3

- [1] x 5pcs
- [3] x 5pcs

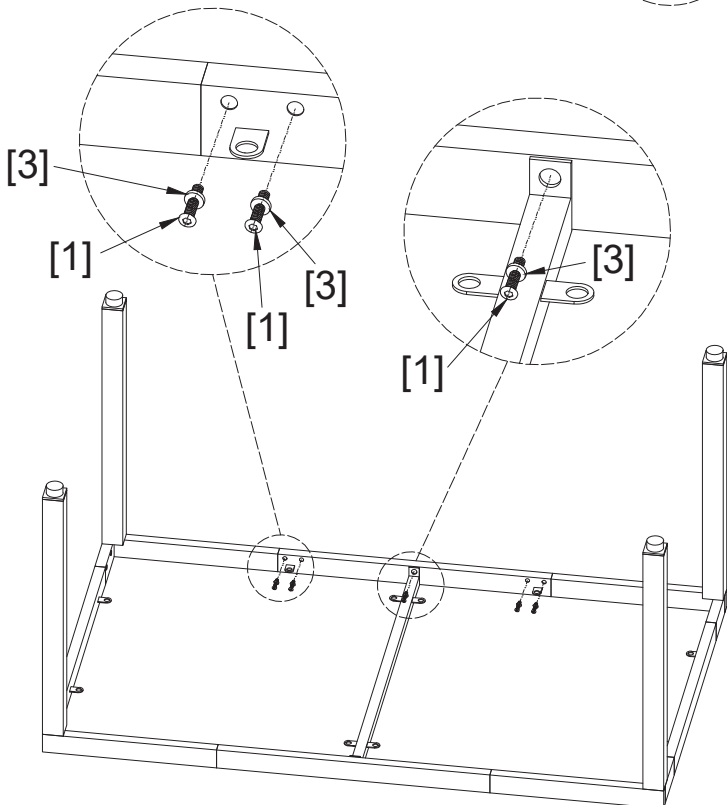

STEP 4

- [F] x 2pcs
- [2] x 12pcs

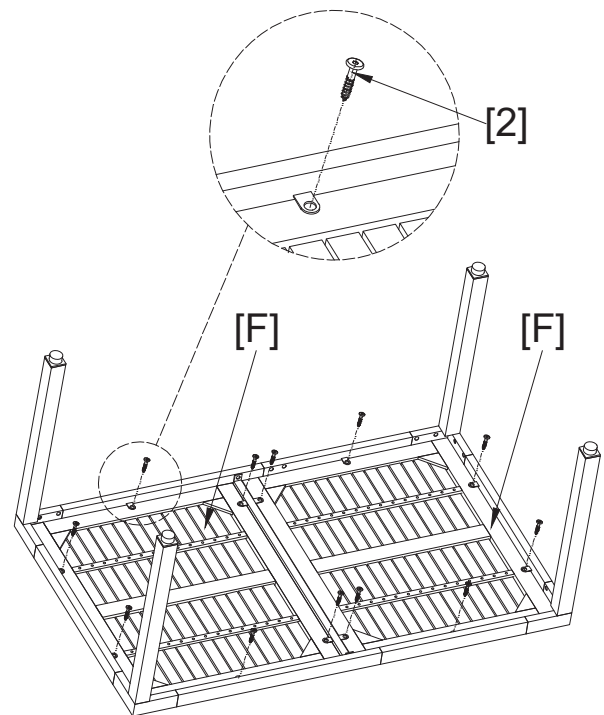

STEP 5

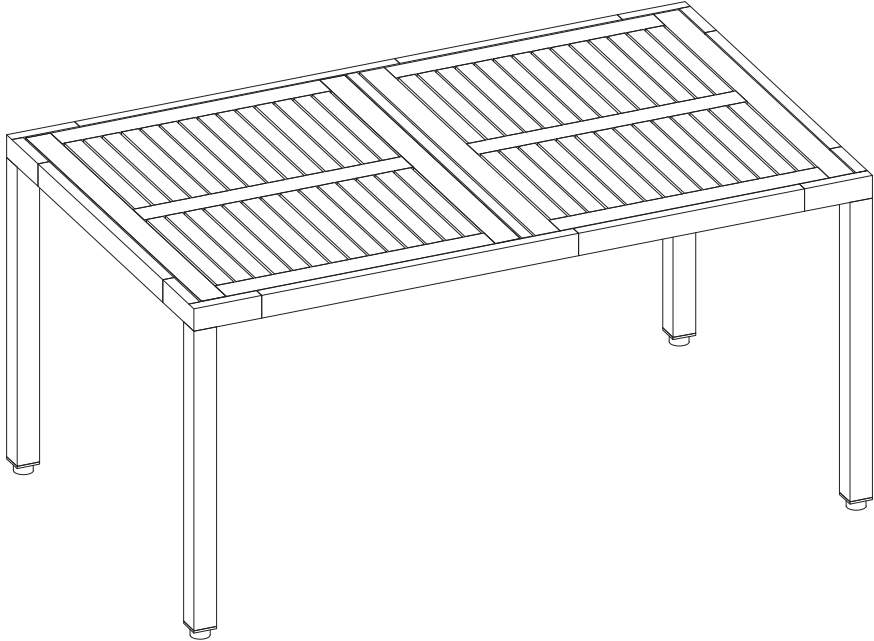

FINISH TABLE

STEP 6

- [J] x 1pc
- [G] x 1pc
- [H] x 1pc

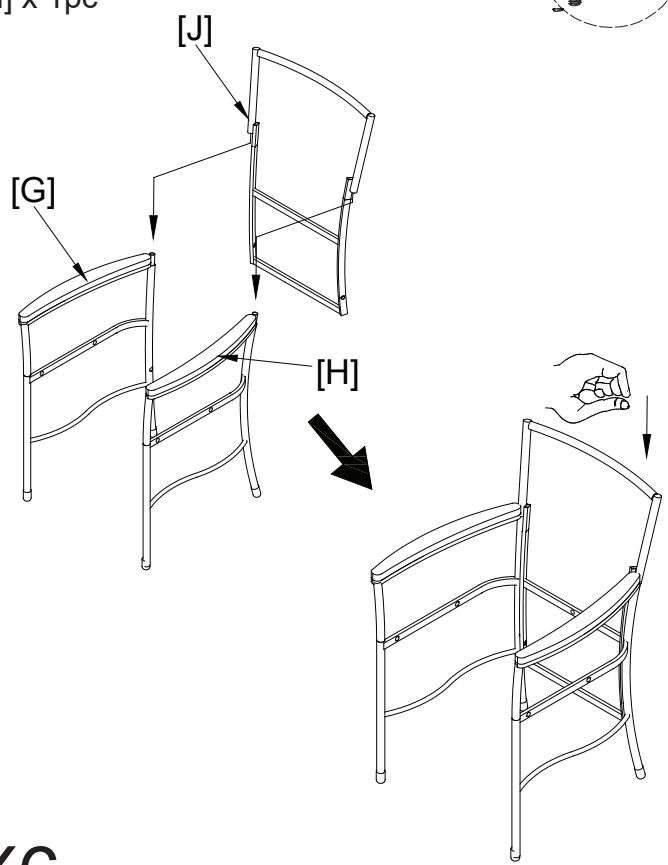

X6

STEP 7

- [3] x 2pcs
- [4] x 2pcs

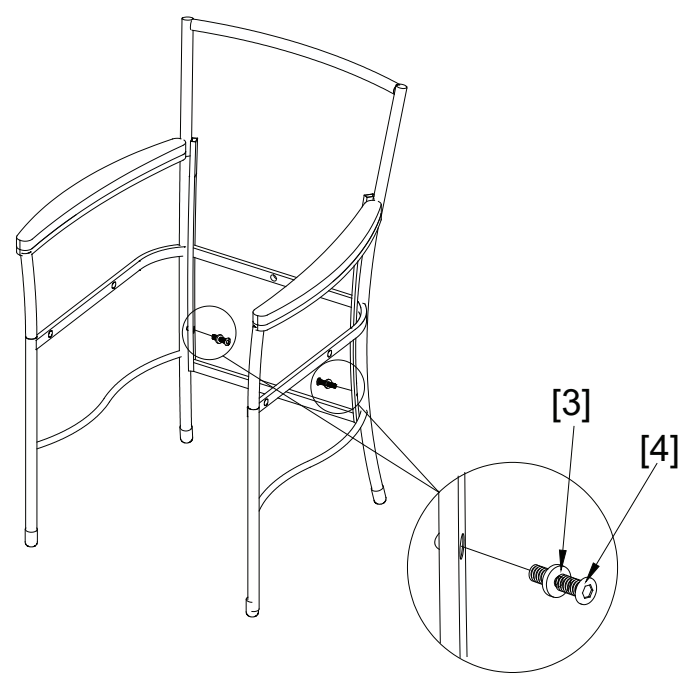

X6

STEP 8

- [1] x 1pc
- [3] x 1pc
- [5] x 1pc

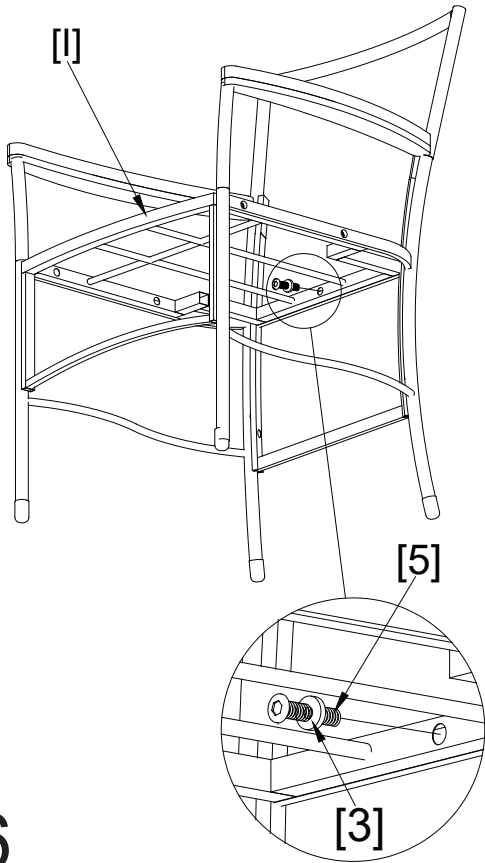

X6

STEP 9

- [3] x 6pcs
- [4] x 2pcs
- [5] x 4pcs

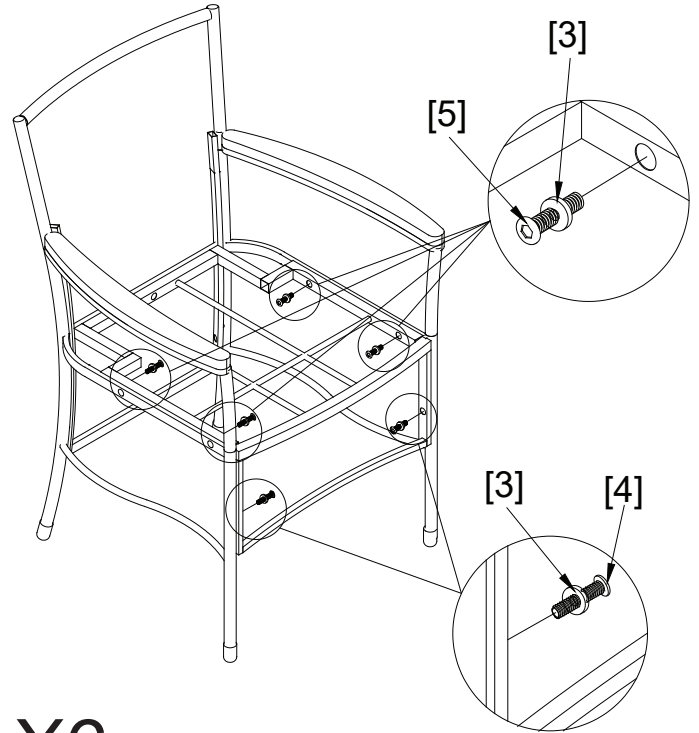

X6

STEP 10

- [K] x 1pc

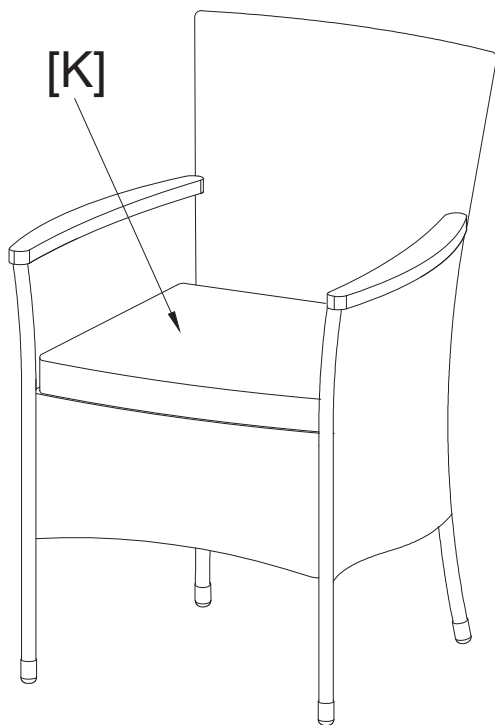
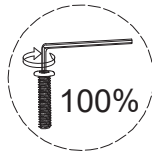

X6

FINISH CHAIR

STEP 11

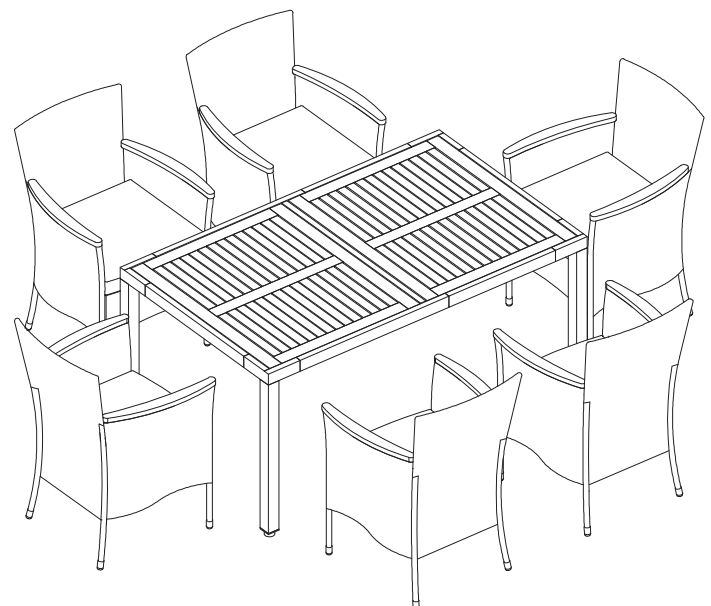

FINISH SET