

# OWNER'S MANUAL

Original instruction manual

SE1017(TXL/F/Q)

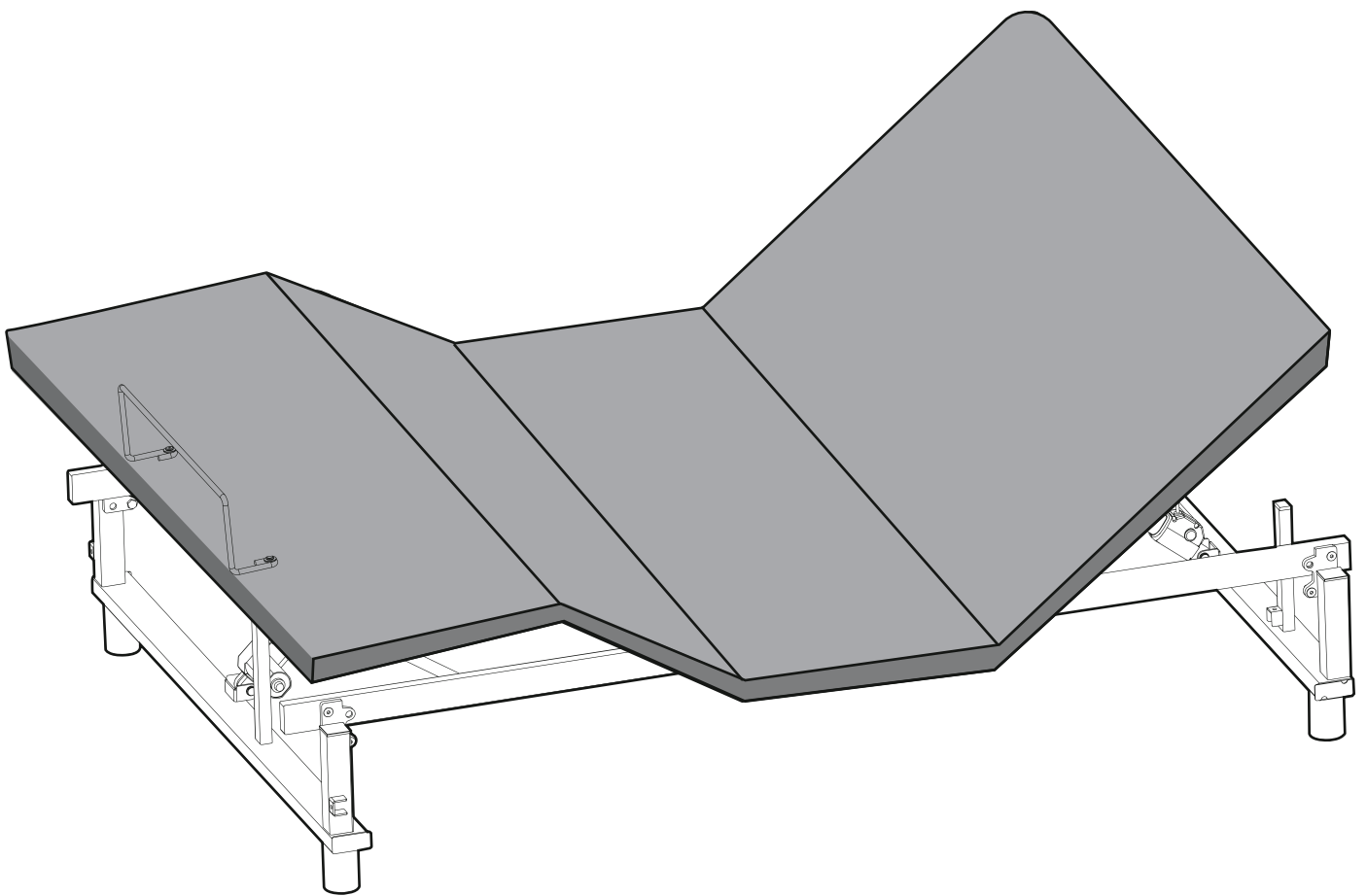

Please read the manual carefully and keep it safe for future maintenance.

# Safety Precautions and Usage Statements

## ATTENTION: IMPORTANT SAFETY DISCLAIMERS

Read all instructions before using your bed.  
Save these instructions.

### 1. TO REDUCE THE RISK OF SHOCK, BURNS, FIRE OR INJURY:

1.1 Always unplug the base from the electrical outlet before servicing any part of the base. To reduce risk of electric shock, unplug the base before cleaning. To safely disconnect, ensure the base is in a flat position with all motors off, and unplug from power source.

1.2 Keep the power cord away from heated surfaces. Never operate the base when the air openings are blocked. Keep air openings free of lint, hair and the like. Do not drop or insert any object into any opening.

1.3 Discontinue use of the bed base and contact a qualified service center if: it has a damaged cord or plug, is not working properly, or has been dropped into water.

1.4 Only use this bed base for its intended use as described in this manual. Do not use accessories/attachments that are not recommended by the manufacturer.

1.5 Close supervision is required when the bed base is used by or near children, convalescents or disabled persons.

### 2. IN-HOME USE AND HOSPITAL DISCLAIMER:

2.1 The bed base is designed solely for in-home use. This base was not designed as a hospital bed and is not designed to meet hospital standards. Do not use this base with TENT TYPE oxygen therapy equipment or near explosive gases.

### 3. OUTLET SAFETY:

#### **FOR OPTIMAL SAFETY AND OPERATION, PLUG BED BASE INTO A SURGE PROTECTOR (NOT INCLUDED).**

3.1 The bed base should only be plugged directly into a wall outlet or surge protector (recommended). Improper connection of the equipment can result in the risk of electrical shock, electrical fire or faulty operation of this bed base. If the plug does not fit your outlet, contact a qualified electrician to install a suitable outlet. Unauthorized modification or failure to use a wall outlet or surge protector could void the electrical portion of your warranty.

### 4. SAFETY FEATURES:

4.1 Manual operation – If something gets caught in the platform when flattened, you can manually raise the platform up by lifting at both the head and foot to relieve pressure and allow for release.

### 5. WARRANTY WARNING:

5.1 Do not open or tamper with control box, motors, or remote (with the exception of battery compartments). The warranty will be void if the internal workings of these components are tampered with.

### 6. CHILDREN AND PETS:

6.1 Children and pets can be crushed or killed if they become entrapped in moving parts of the bed. Before you reposition the base, check to be sure children and small pets are not near or under the base. Do not teach children to operate the remote.

6.2 Immediately dispose of all packaging materials as they may pose a smothering risk to small children and pets.

### 7. POWER RATINGS:

INPUT: AC 100–240V 50/60 Hz 1.6A

OUTPUT: DC 29V 1.8A

WATTS: 52.2W

### 8. PRODUCT RATINGS:

8.1 The lift motors are not designed to operate continuously for more than two [2] minutes in an eighteen [18] minute time period or approximately 10% duty cycle. Attempting to circumvent or exceed this rating will shorten the life expectancy of the product and may void the warranty.

# Safety Precautions and Usage Statements

## 9. WEIGHT LIMITS:

9.1 The recommended weight limits on the bed are: Twin / Twin Long / Full / Queen / King / Cal King / Cal King Split : 750 pounds (Including mattress) .

9.2 Maximum weight the bed can support per person is 250 pounds with the weight evenly distributed across the head and foot sections. This product is not designed to support or lift this amount of weight in the head or foot sections alone. NOTE: Exceeding the recommended weight restrictions could damage your bed and void your warranty. For best performance, you should enter and exit the bed while it is in the flat or fully lowered position.

9.3 Bed fits easily inside bed frames, furniture beds and platform beds that are certified to hold a minimum of 850 pounds. If using this adjustable base without the legs and placing directly on a bed frame or platform bed, cross-bed supports (slats) are strongly recommended to ensure the base maintains stability during operation.

## **EXCEEDING THIS WEIGHT RESTRICTION COULD DAMAGE THE BED AND/OR CAUSE INJURY AND WILL VOID THE WARRANTY.**

## 10. ACOUSTICS:

10.1 In normal base operation the wheels, which allow the bed to maintain its distance from the wall, will make contact with the steel platform supports of the base creating a contact noise. When entering, exiting or shifting weight on the base, this contact noise may be audible as the wheels make contact. This is normal.

## 11. FABRIC CARE:

11.1 To prolong the life of your fabric, protect from direct sunlight whenever possible. For spot cleaning, wipe area with a light damp sponge or vacuum with a soft brush attachment to remove particles. Keep at a minimum of 30cm (12 inches) away from direct heat sources.

11.2 For deeper cleaning, blot liquid spills with a clean dry cloth. Wipe with a clean cloth dampened with warm water. Do not wet excessively. A soft bristle brush may be used to remove ingrained soil. Avoid scratching by gentle brushing. Wipe with a clean cloth dampened with warm water to remove residues after brushing. Dry in shade away from direct heat.

11.3 If persistent marks remain visible after cleaning, seek professional advice.

## SAVE THESE INSTRUCTIONS.

### FCC COMPLIANCE:

NOTE: This equipment has been tested and found to comply with the limits for a Class B digital device, pursuant to part 15 of the FCC Rules. These limits are designed to provide reasonable protection against harmful interference in a residential installation. This equipment generates, uses and can radiate radio frequency energy and, if not installed and used in accordance with the instructions, may cause harmful interference to radio communications. However, there is no guarantee that interference will not occur in a particular installation. If this equipment does cause harmful interference to radio or television reception, which can be determined by turning the equipment off and on, the user is encouraged to try to correct the interference by one or more of the following measures:

- Reorient or relocate the receiving antenna.
- Increase the separation between the equipment and receiver.
- Connect the equipment into an outlet on a circuit different from that to which the receiver is connected.

# Disassembly Instructions

**1** Open the packaging cardboard box.

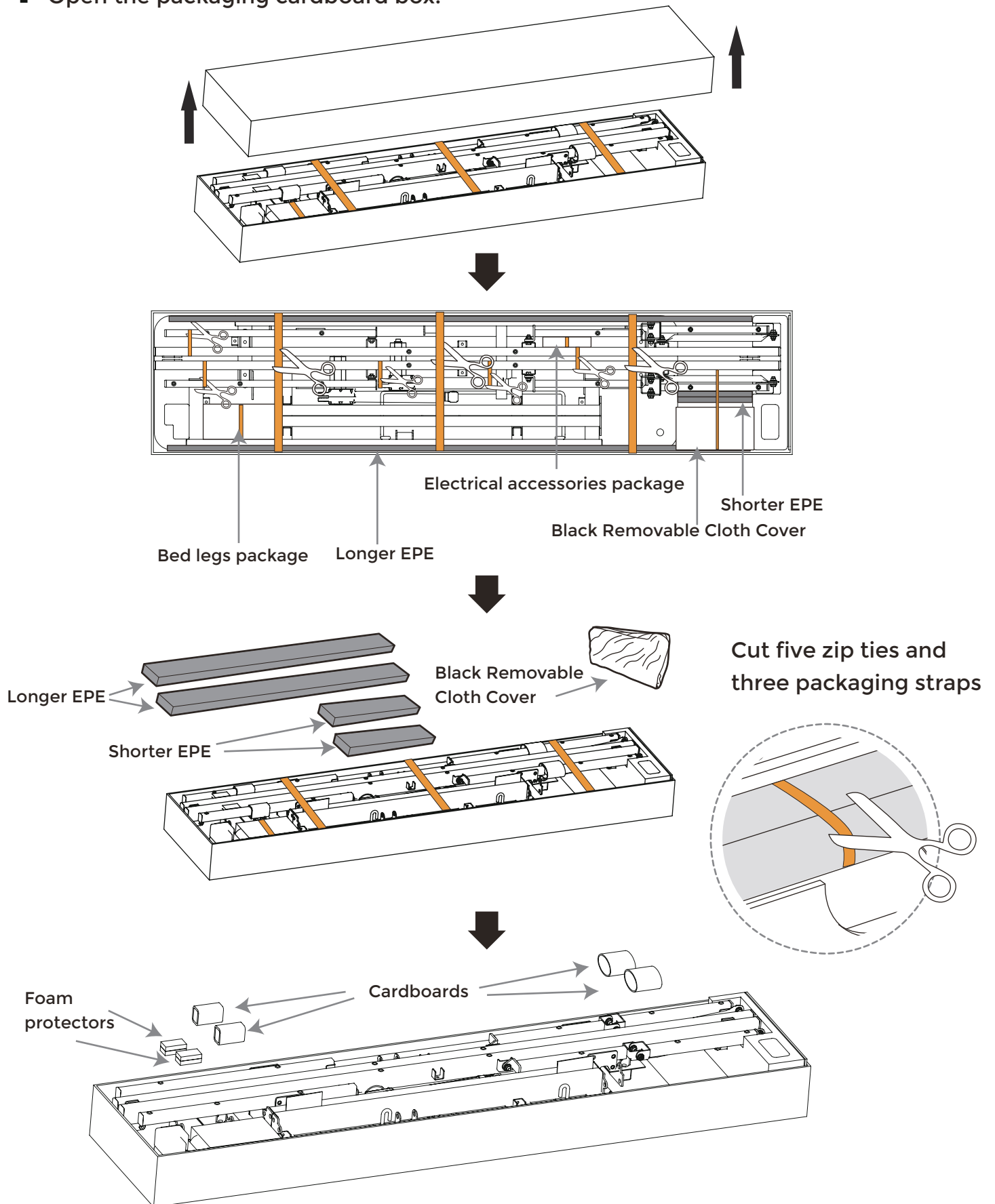

# Disassembly Instructions

**2** Lift the cross tube up and turn the screw as shown.

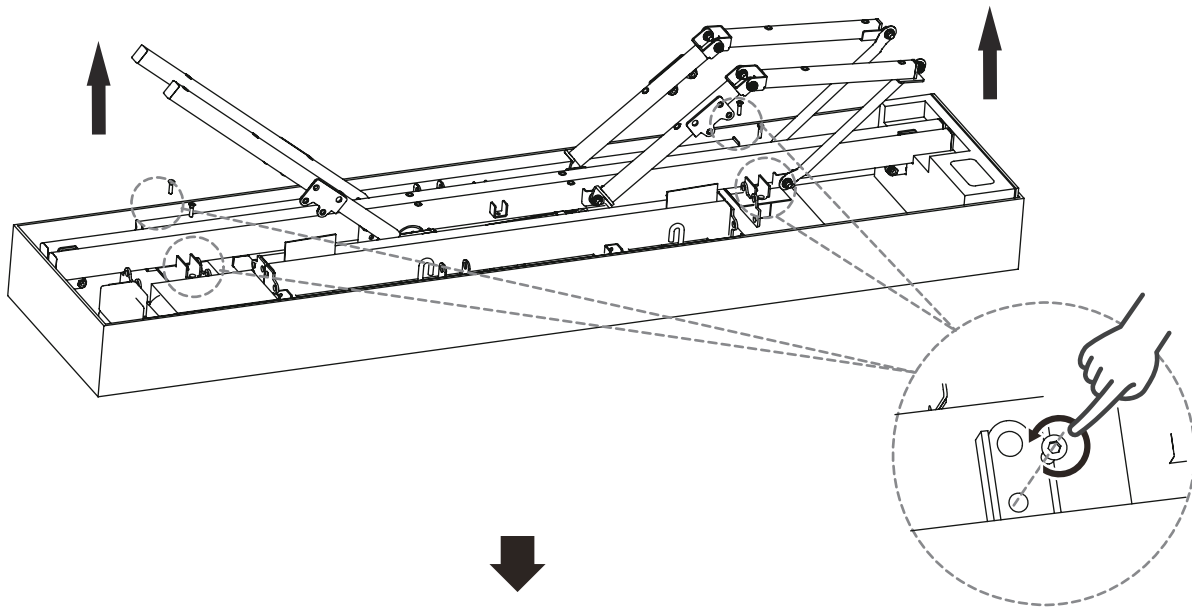

Remove the two brackets.

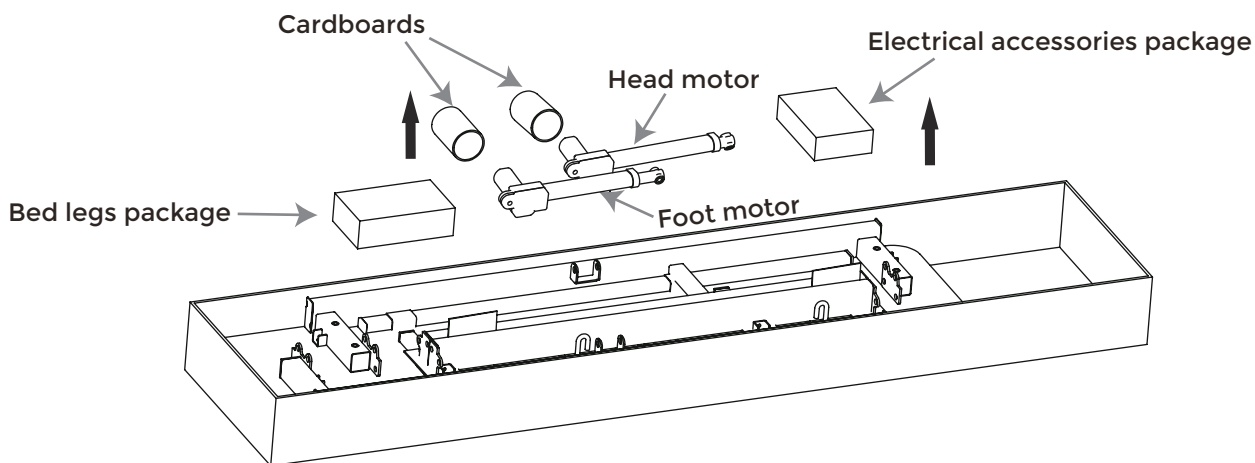
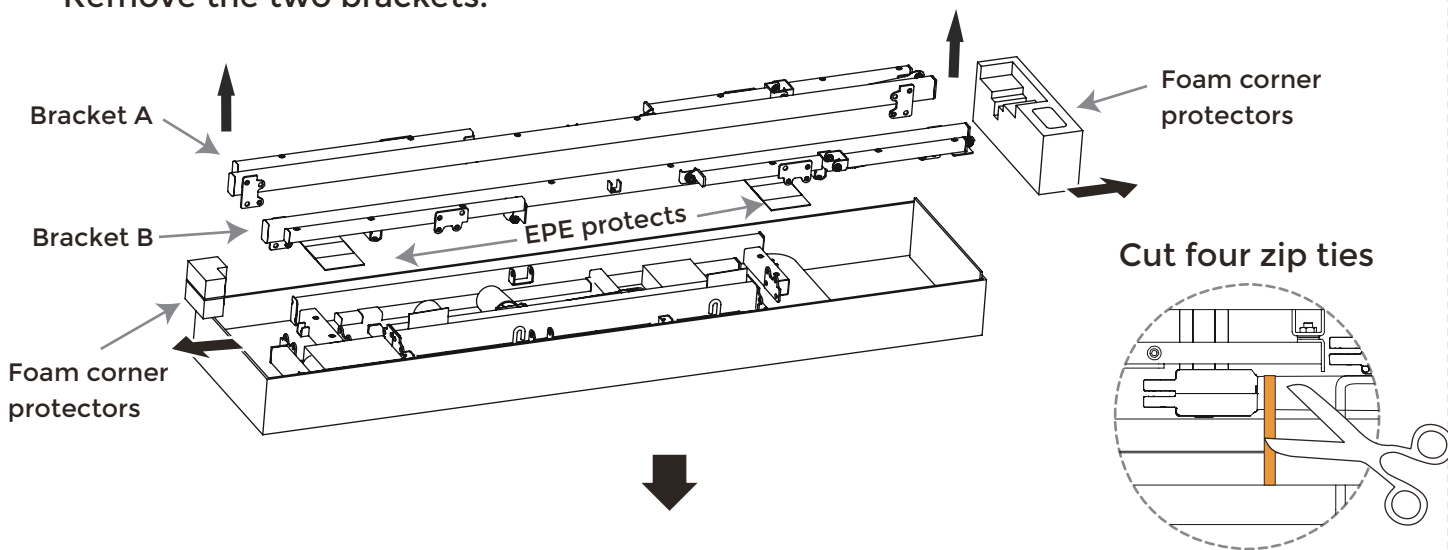

# Disassembly Instructions

## 3 Remove the motor mount crossbars.

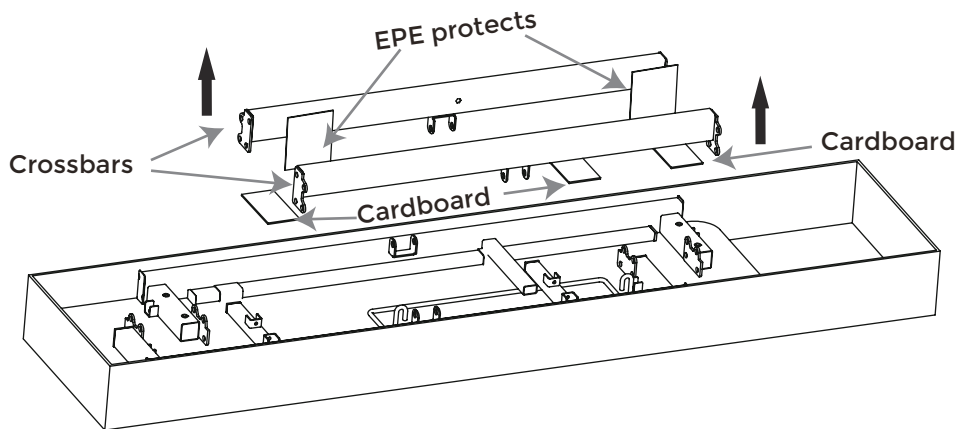

Unscrew the four screws as shown.

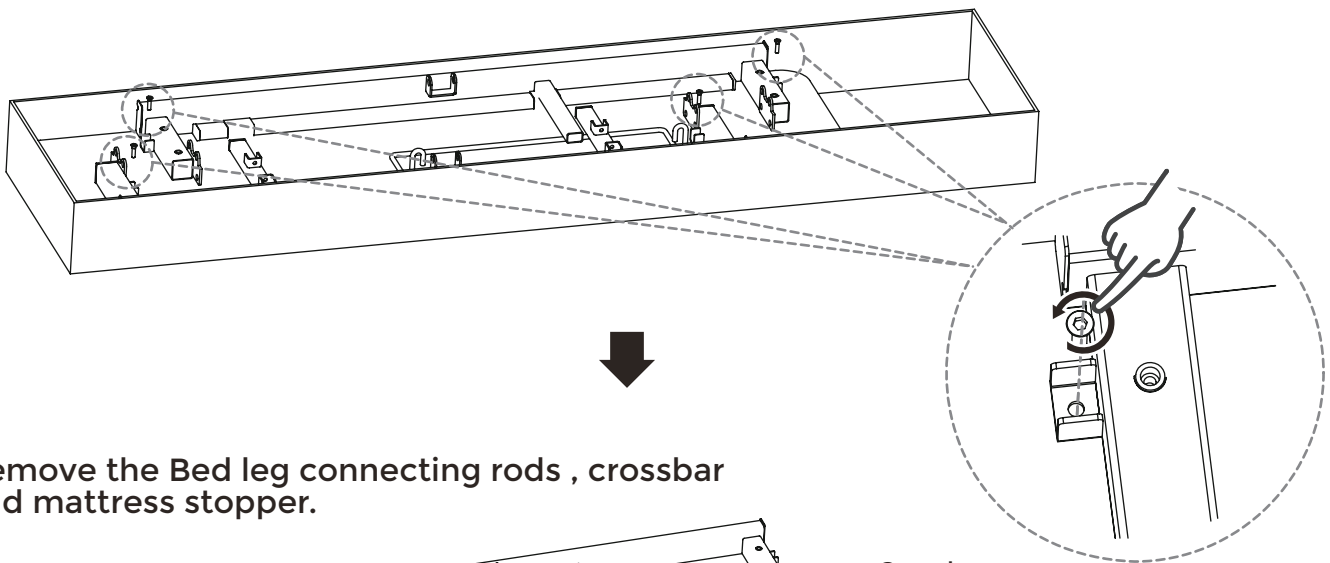

Remove the Bed leg connecting rods , crossbar and mattress stopper.

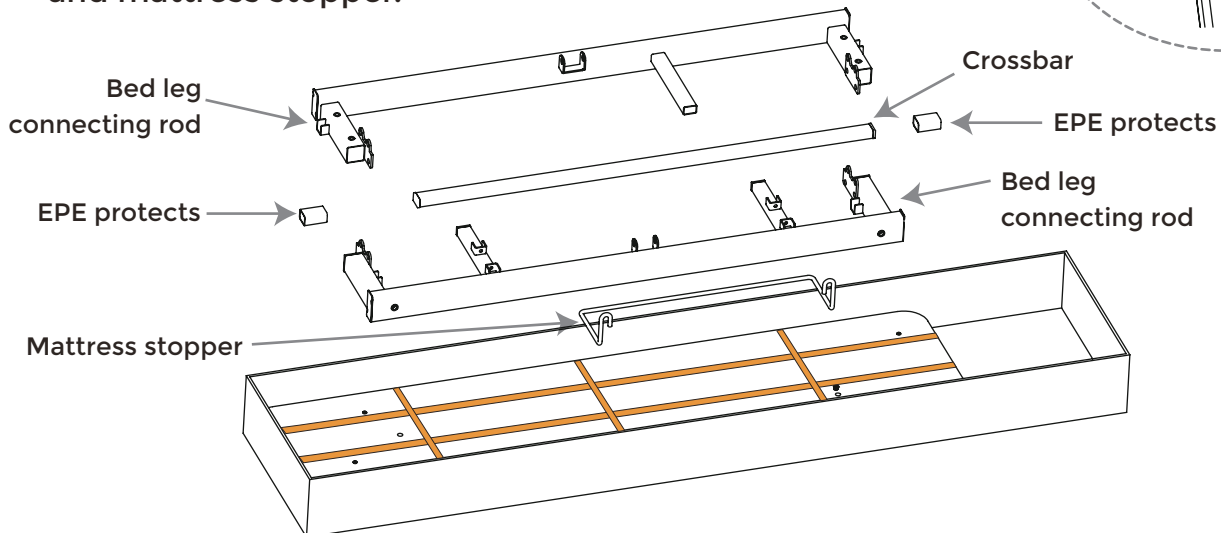

# Disassembly Instructions

**4** (The Size K boards are packaged with only three packaging straps.)

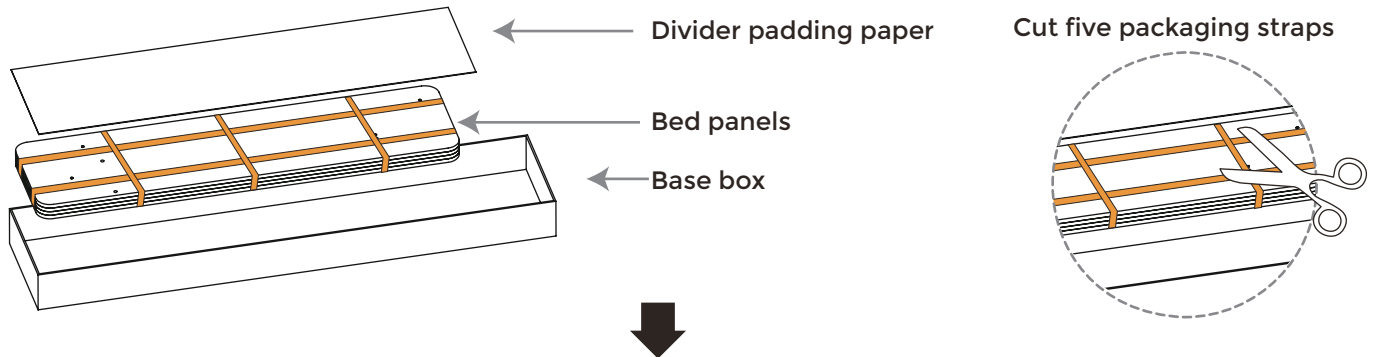

Retrieve the five bed panels.

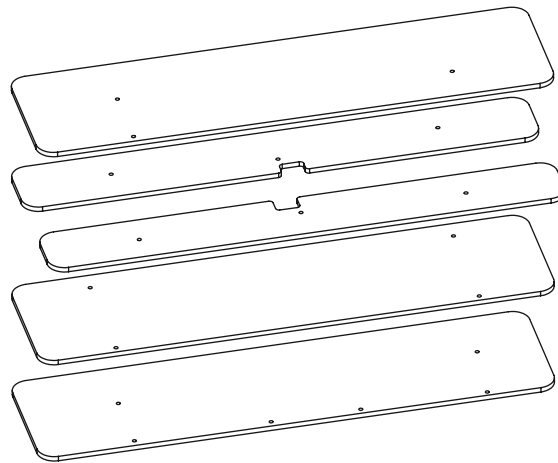

## Parts list







**BEFORE DISCARDING THE PACKING MATERIALS, ENSURE ALL THE PARTS ARE ACCOUNTED FOR.**  
ALL ELECTRONICS AND COMPONENTS THAT NEED TO BE INSTALLED ARE LOCATED IN BOXES UNDER THE BASE OR ATTACHED TO THE FRAME.

<p><b>A</b> 1×</p>	<p><b>B</b> 1×</p>	<p><b>C</b> 1×</p>	<p><b>D</b> 1×</p>	<p><b>E-1</b> 1×</p>
<p><b>E-2</b> 1×</p>	<p><b>F</b> 1×</p>	<p><b>G1</b> 1×</p> <p><b>Controller</b></p>	<p><b>G2</b> 1×</p> <p><b>Remote control</b></p>	<p><b>G3</b> 1×</p> <p><b>Power adapter</b></p>

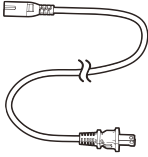
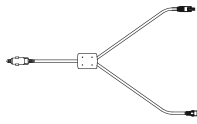
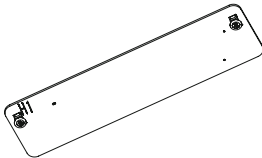
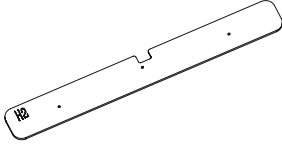
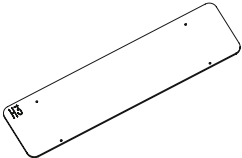
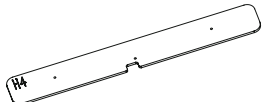
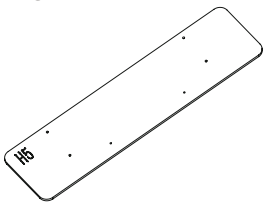
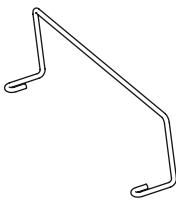
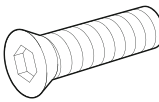
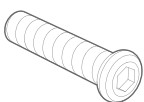
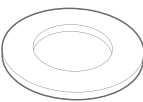
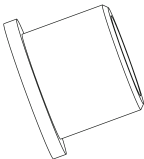
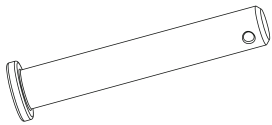
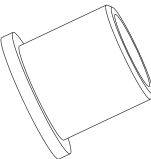
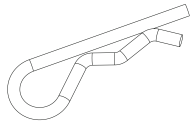
# Parts list

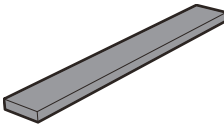
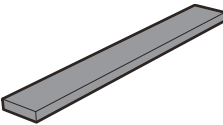
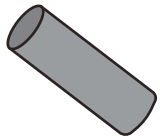
**BEFORE DISCARDING THE PACKING MATERIALS, ENSURE ALL THE PARTS ARE ACCOUNTED FOR.**

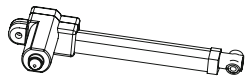
ALL ELECTRONICS AND COMPONENTS THAT NEED TO BE INSTALLED ARE LOCATED IN BOXES UNDER THE BASE OR ATTACHED TO THE FRAME.

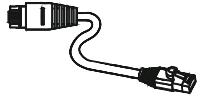
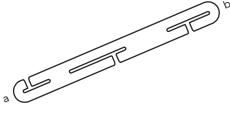
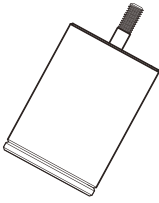
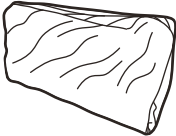
<b>G4</b> 1×  <b>Power code</b>	<b>G5</b> 1×  <b>Controller adapter cable</b>	<b>H1</b> 1×  	<b>H2</b> 1×  	<b>H3</b> 1×  
<b>H4</b> 1×  	<b>H5</b> 1×  	<b>I</b> 1×  	<b>S1</b> 20×  <b>M8*20</b>	<b>S2</b> 19×  <b>M6*30</b>
<b>S4</b> 2×  <b>Gasket</b>	<b>S5</b> 4×  <b>Yellow Shaft Sleeve</b>	<b>S6</b> 4×  <b>Dowel</b>	<b>S7</b> 4×  <b>Red Shaft Sleeve</b>	<b>S8</b> 4×  <b>Circlip</b>
<b>S9</b> 1×  <b>M6</b>	<b>S10</b> 1×  <b>M8</b>	<b>S11</b> 2×  <b>Longer EPE</b>	<b>S12</b> 2×  <b>Shorter EPE</b>	<b>S13</b> 1×  <b>Black cloth cover</b>
<b>S14</b> 5×  <b>Zip ties</b>	<b>K1</b> 1×  <b>Head motor</b>	<b>K2</b> 1×  <b>Foot motor</b>	<b>K3</b> 1×  <b>Sync Cord</b> (for small size beds only)	<b>K4</b> 1×  <b>Connecting Straps</b> (for small size beds only)
<b>J</b> 4×  	<b>T</b> 1×  <b>Black removable cloth cover</b>			



THESE ITEMS ARE ATTACHED TO THE BASE FOR SHIPPING PURPOSES, CAREFULLY REMOVE THEM FROM THE BASE AND SET THEM ASIDE.

Note: Screw package includes S1 through S10.

# Installation Guide

Always use two people when setting up the base.

Before your installation, please make sure that you have all the parts listed on the manual.

**1** Flip C and D to install legs of the bed.

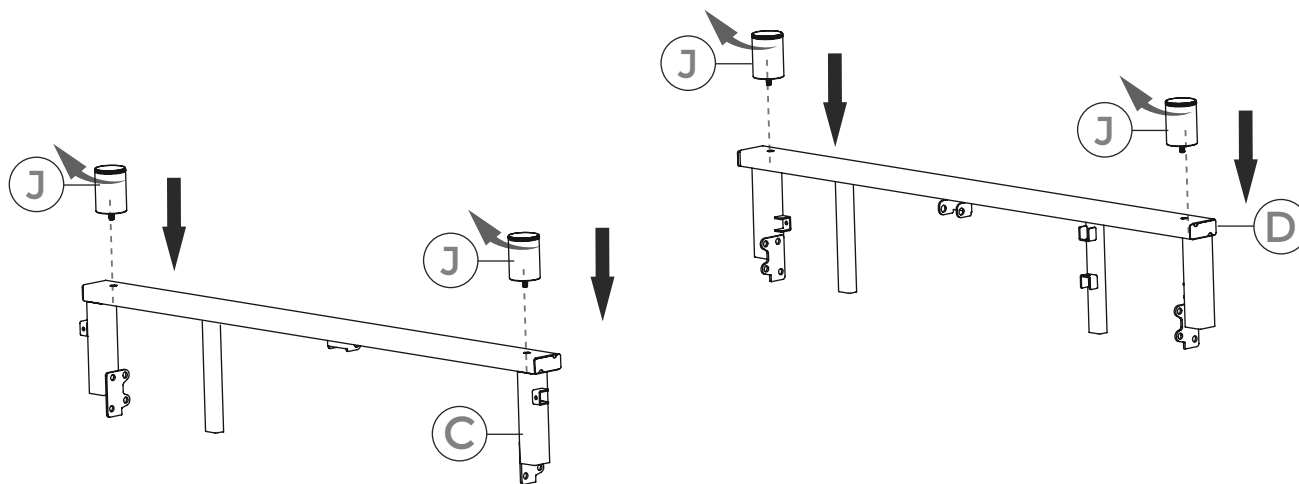

Please ensure that the bed legs are tightened securely.

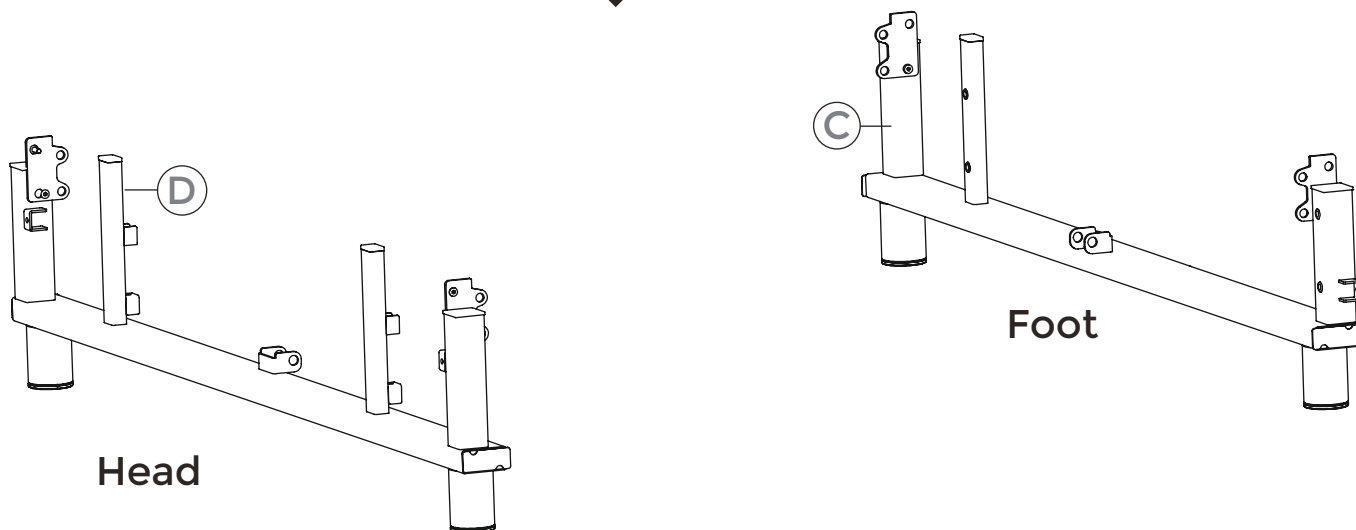

C 1PCS	D 1PCS	J 4PCS

# Installation Guide

## 2

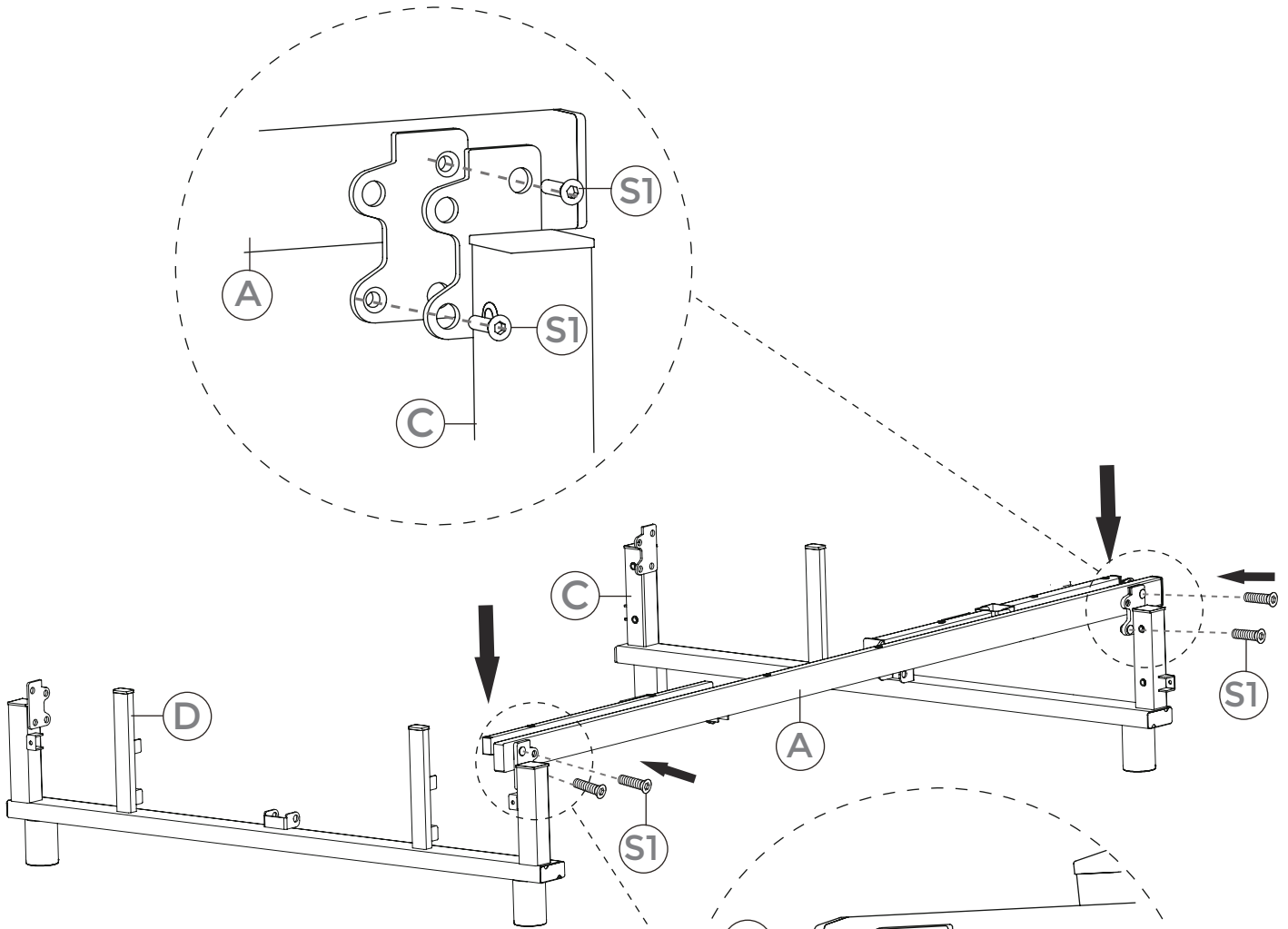

Please ensure that all screws are properly installed before tightening them.

A 1PCS	S10 1PCS	S1(M8*20) 4PCS

# Installation Guide

## 3

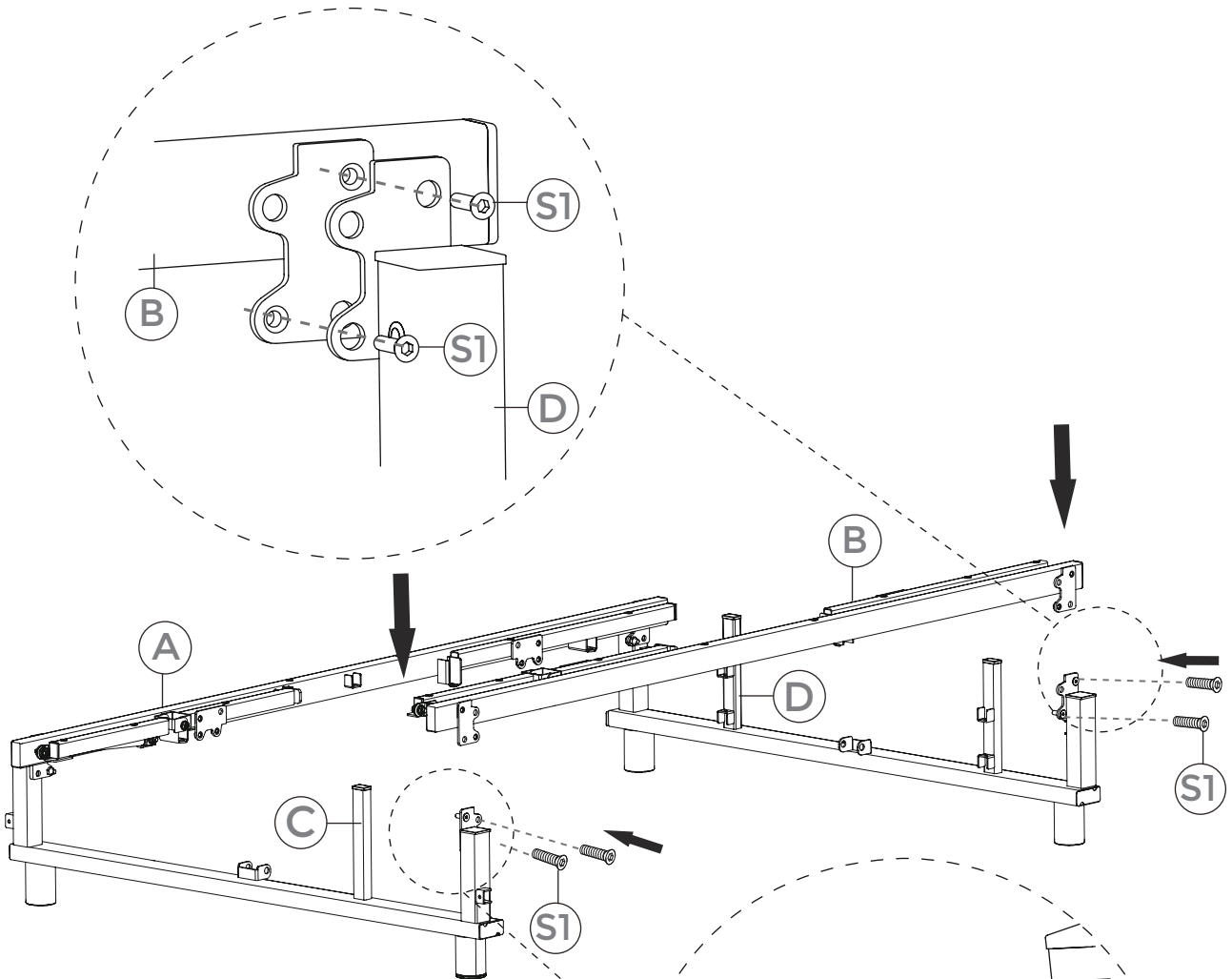

Please ensure that all screws are properly installed before tightening them.

		
B 1PCS	S10 1PCS	S1(M8*20) 4PCS

# Installation Guide

4



Please ensure that all screws are properly installed before tightening them.

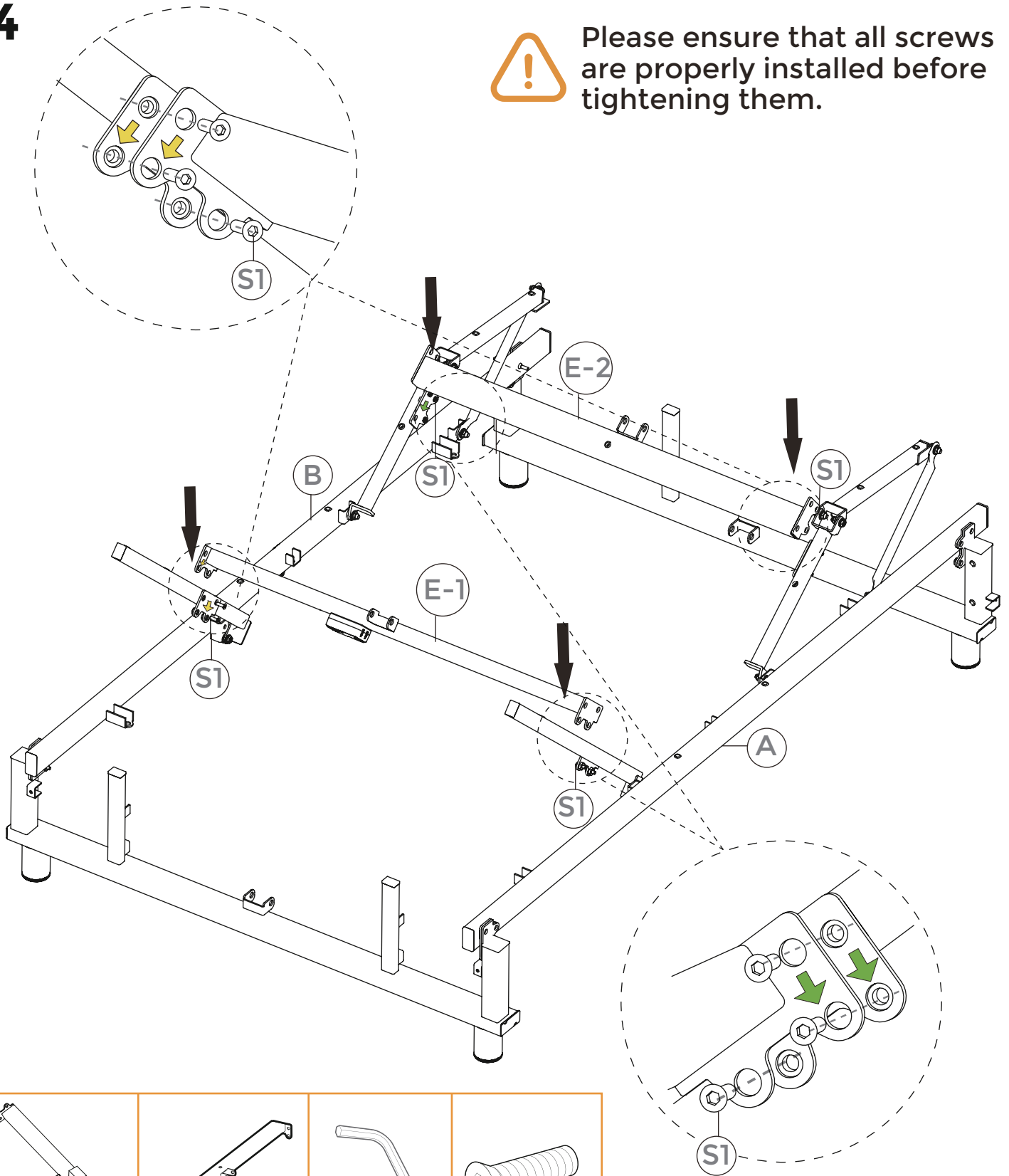

E-1 1PCS	E-2 1PCS	S10 1PCS	S1(M8*20) 12PCS

# Installation Guide

**5**

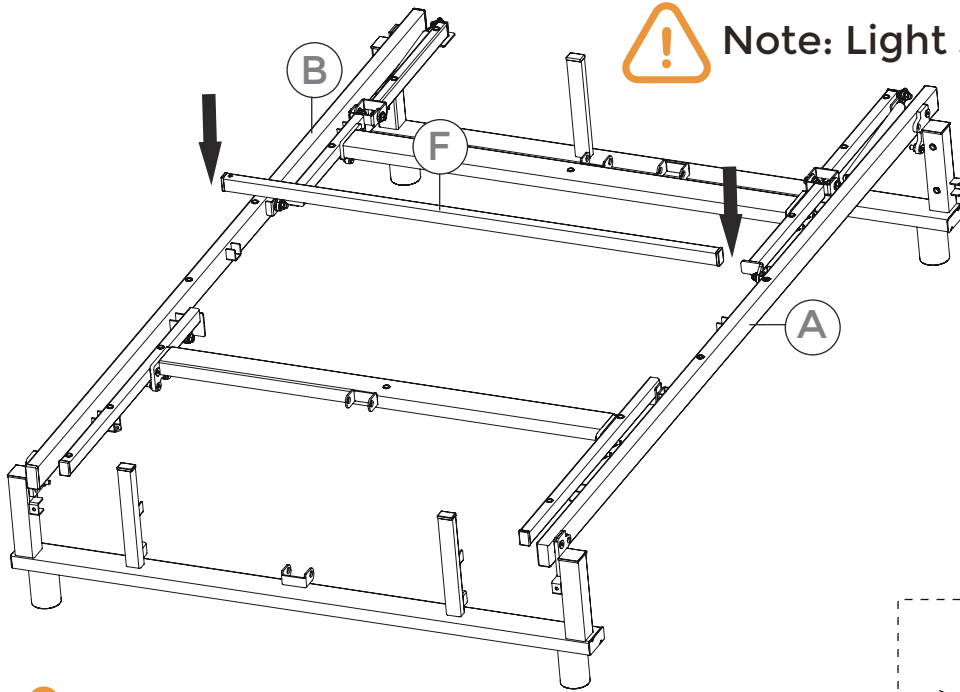

**Note: Light strip facing down.**

**6**

**Note: Motor label mounted face up.**

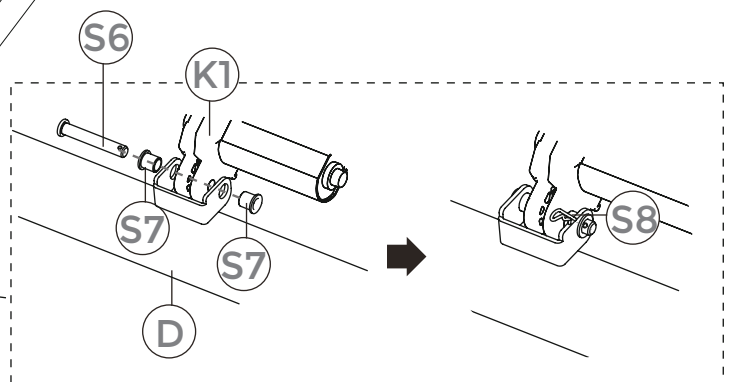
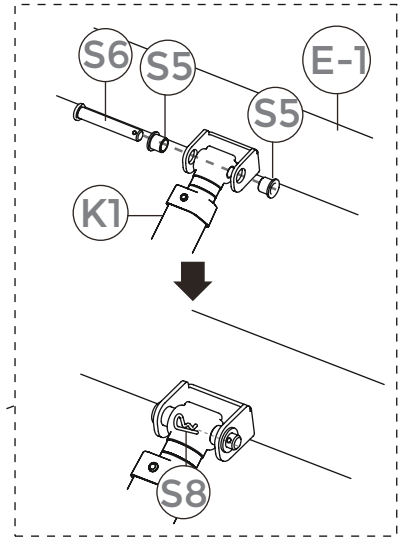
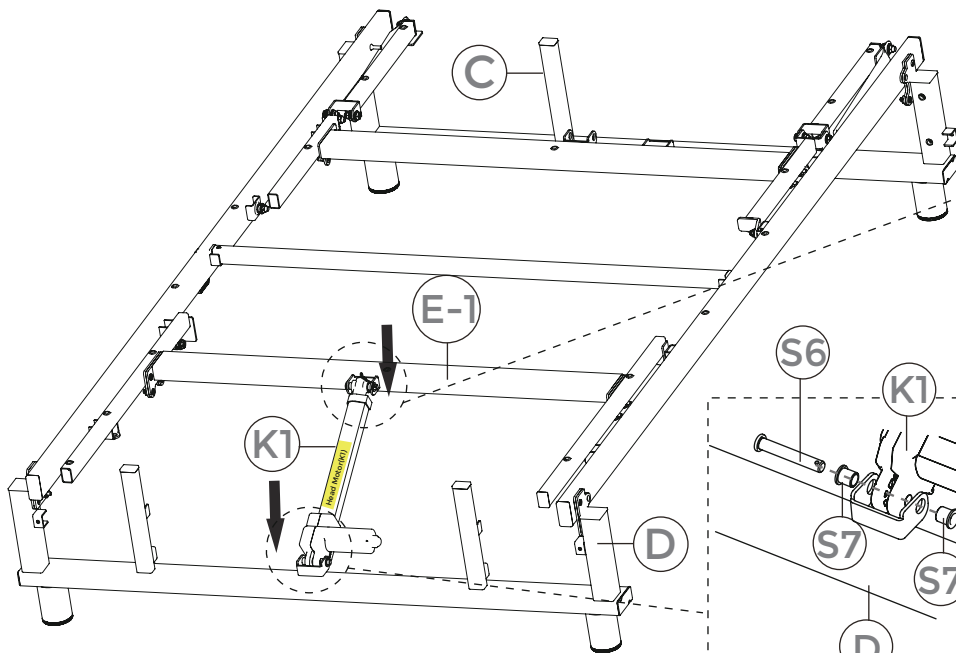

F 1PCS	K1 1PCS	S6 2PCS	S5 2PCS	S7 2PCS	S8 2PCS

# Installation Guide

7



Note: Motor label mounted face up.

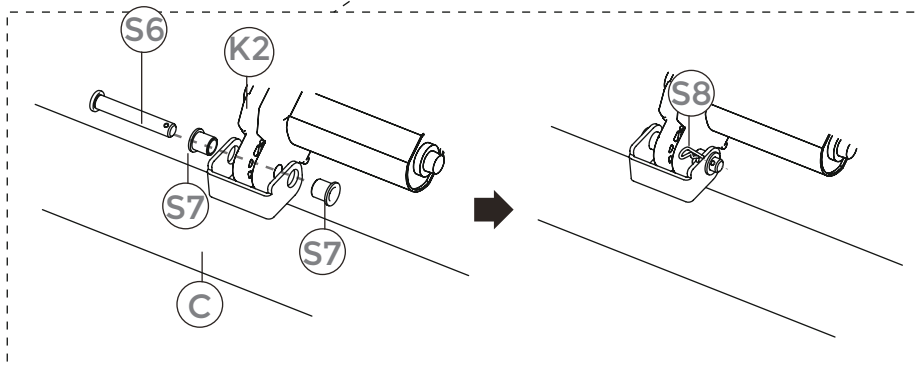
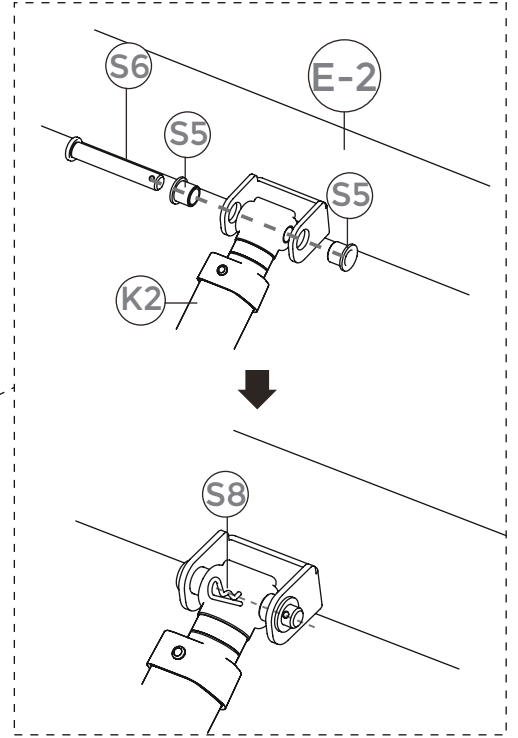
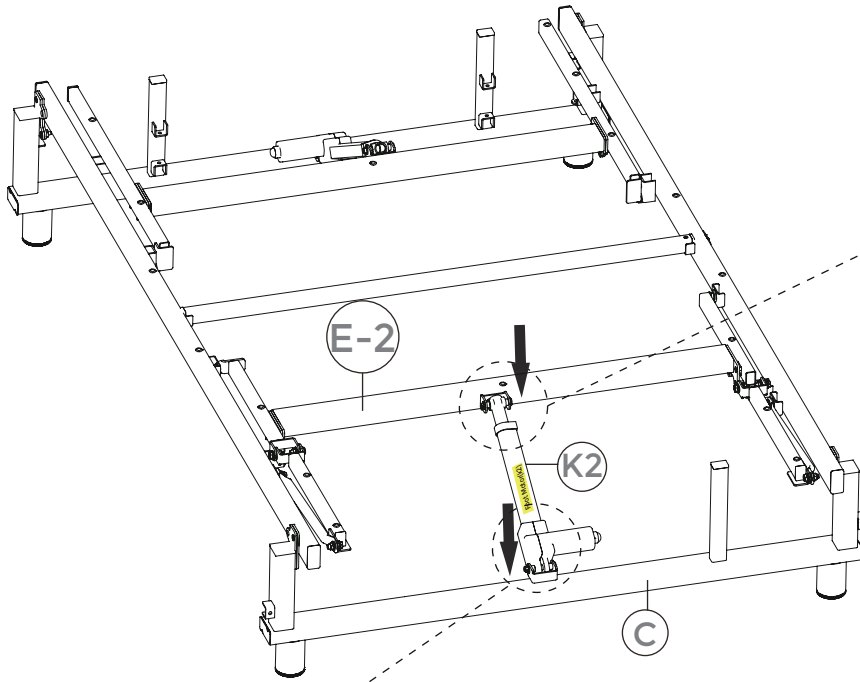

K2 1PCS	S6 2PCS	S5 2PCS	S7 2PCS	S8 2PCS

# Installation Guide

8



Note: Please slide the controller G1 into the plastic base. If you need to remove G1, press the plastic latch on the base and slide out the controller.

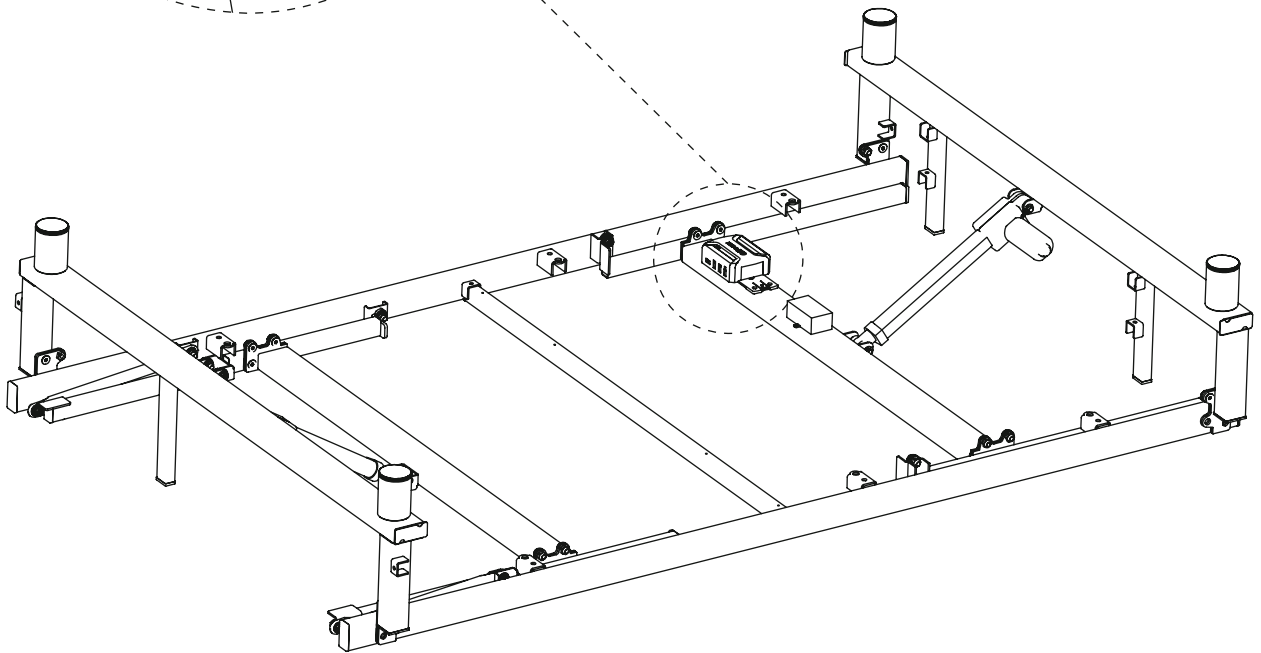
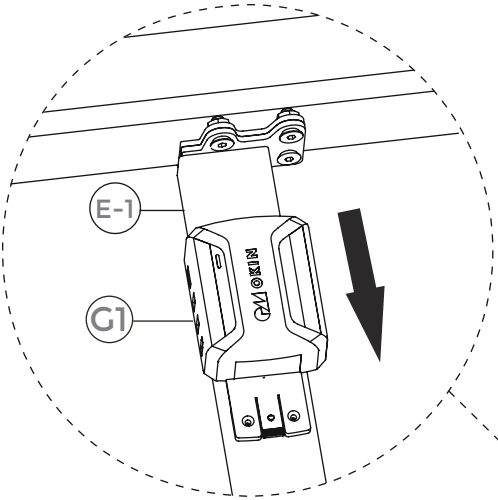

G1 1PCS

# Installation Guide

9

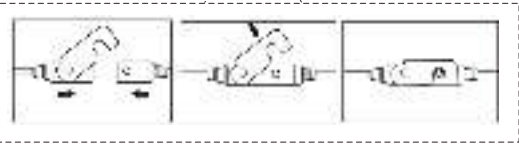
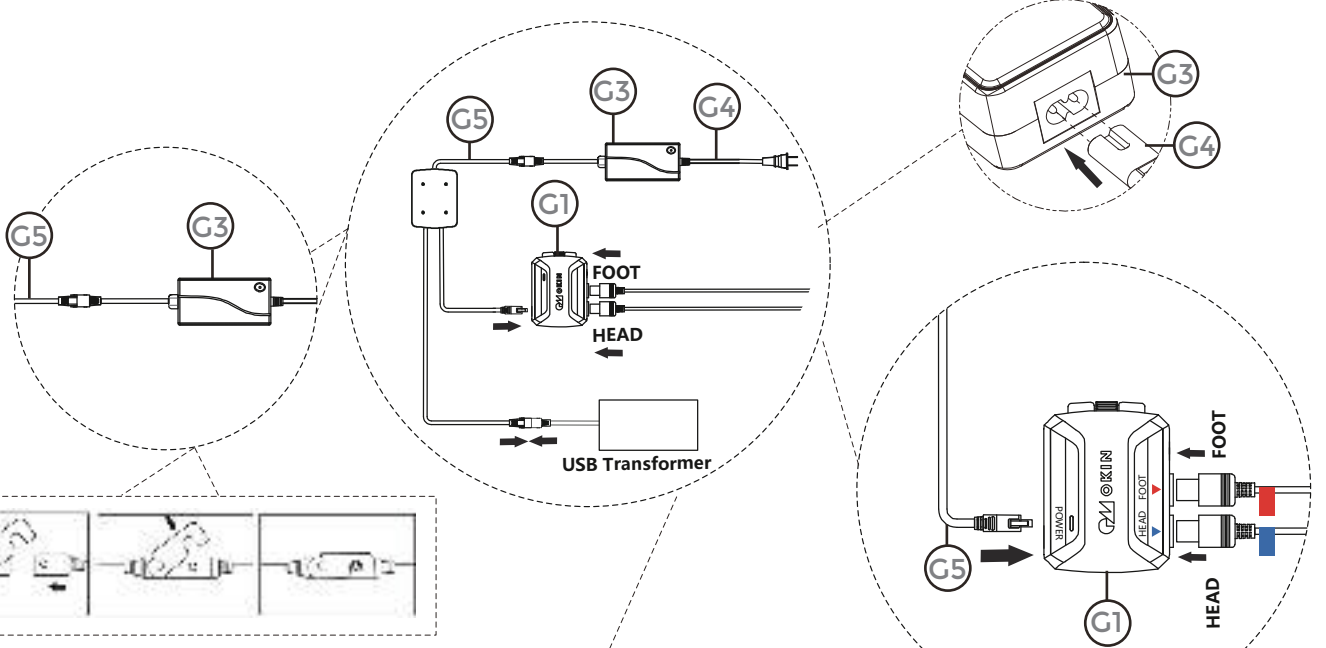

**WARNING:** Please ensure that the wires are not threaded through the bed frame's moving parts to prevent the wires from getting pinched or cut.

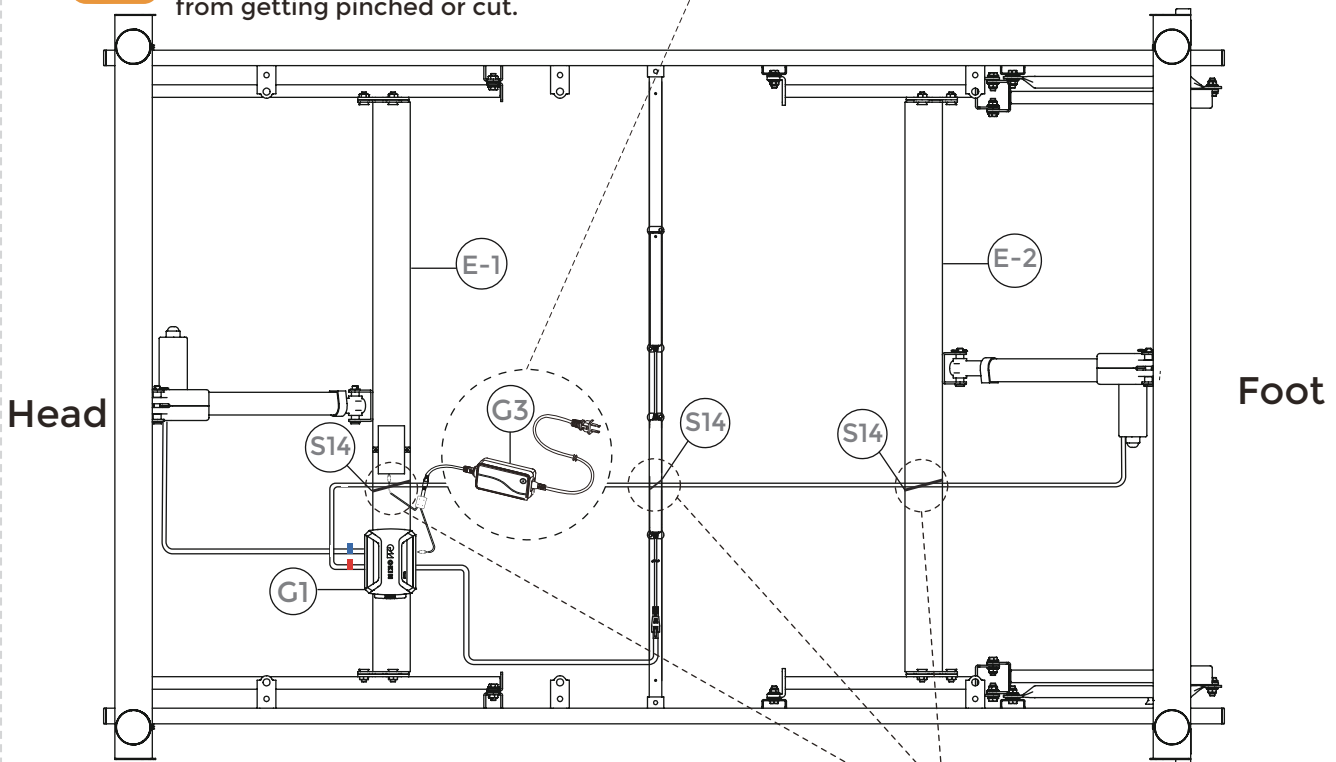

G3 1PCS	G4 1PCS	G5 1PCS	S14 5PCS

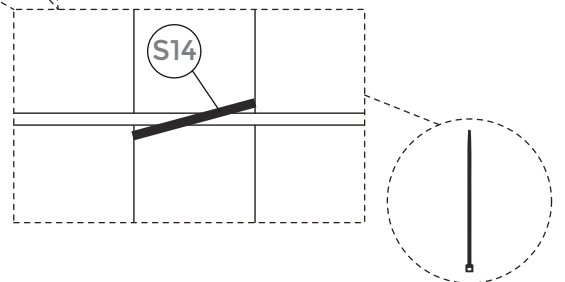

# Installation Guide

## 10

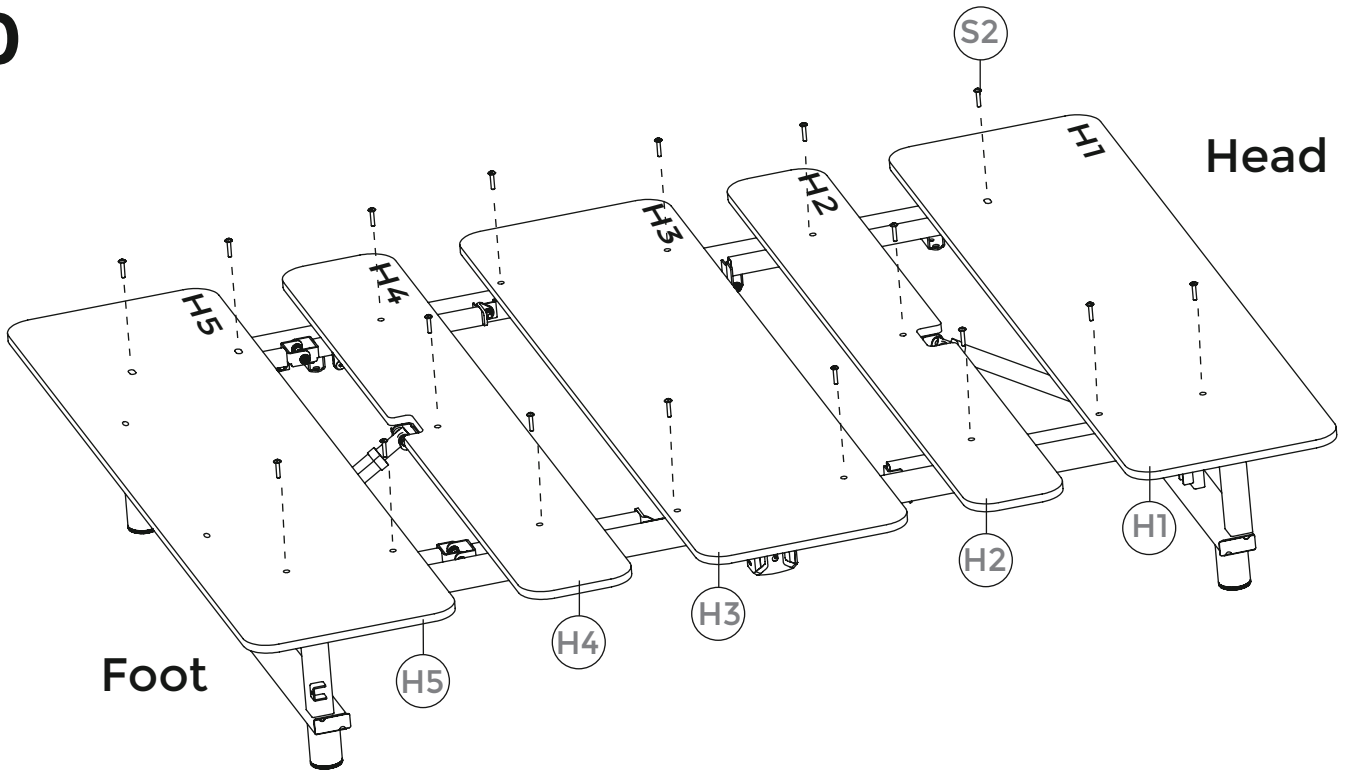

If the holes do not line up, adjust the frame manually.

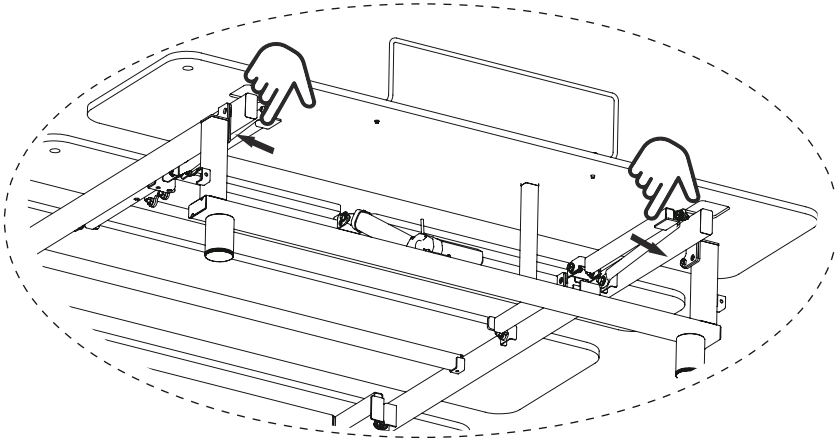

H1 1PCS	H2 1PCS	H3 1PCS	H4 1PCS	H5 1PCS	S2(M6*30) 17PCS

# Installation Guide

## 11 Connect G1 and USB.

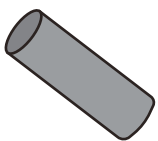
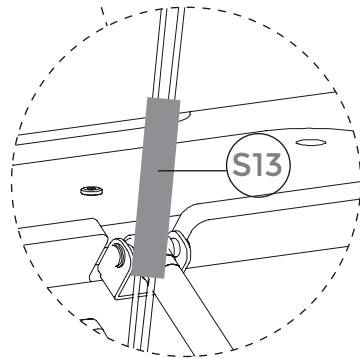
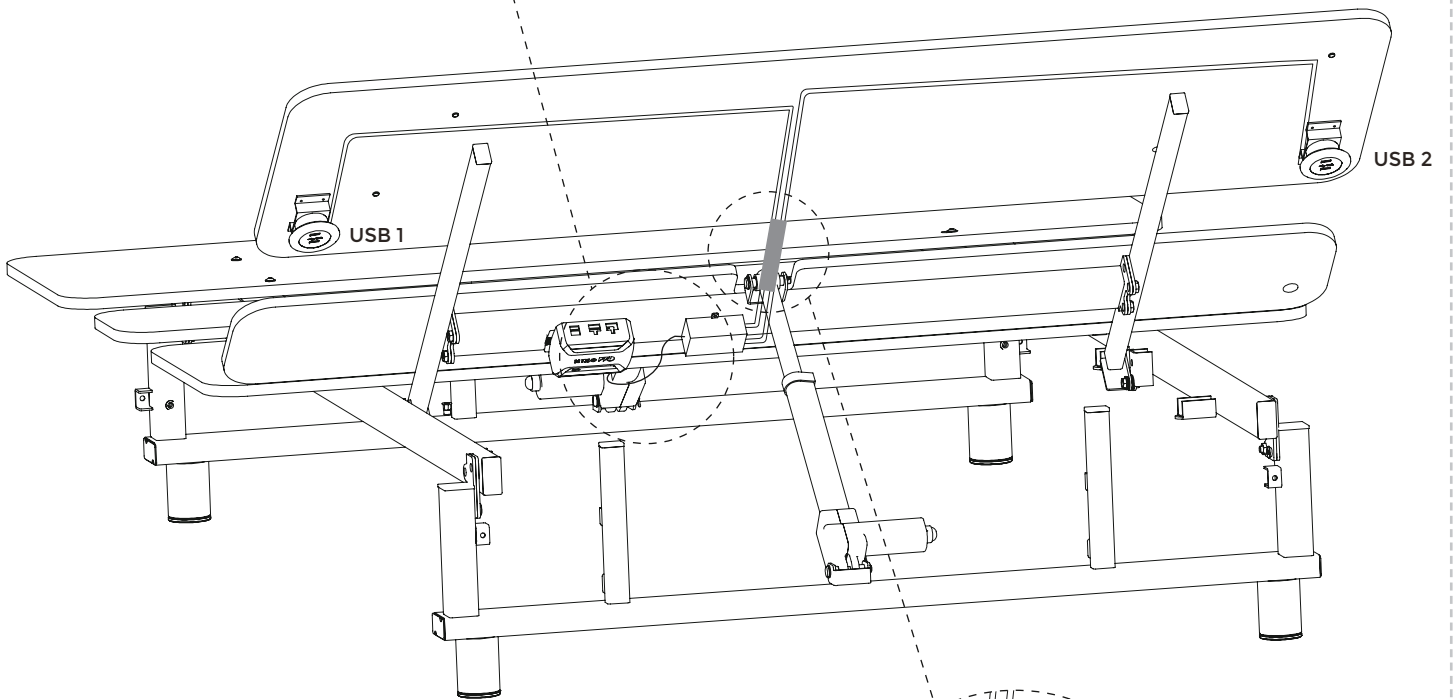
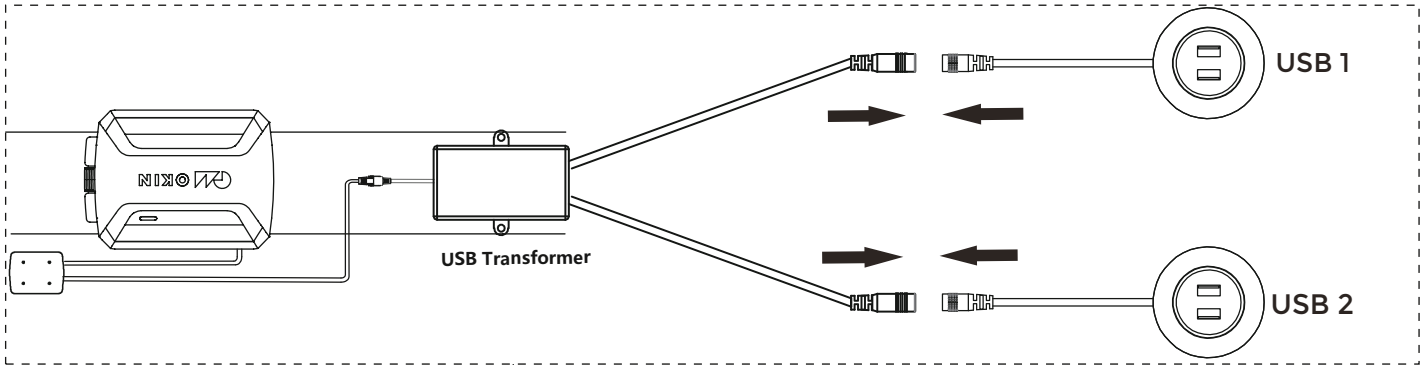

S13 1PCS

# Installation Guide

**12** Flip the bed over and glue the EPE tape tightly along the edge of the bed board.

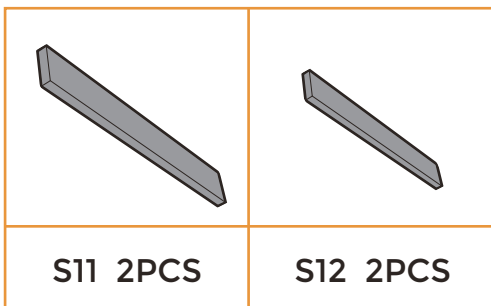
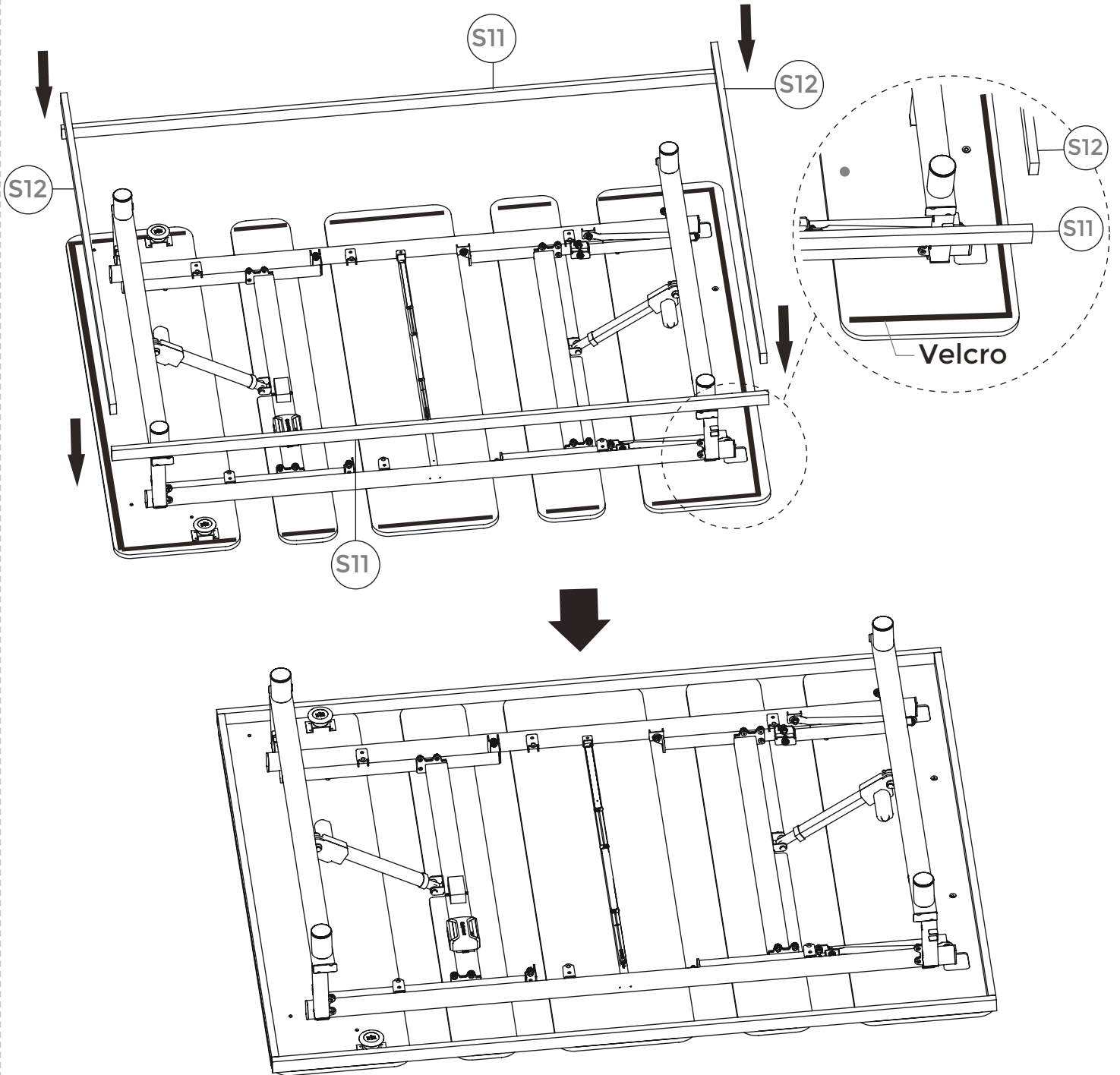

# Put on The Cloth Cover

## 1 Put on The Cloth Cover.

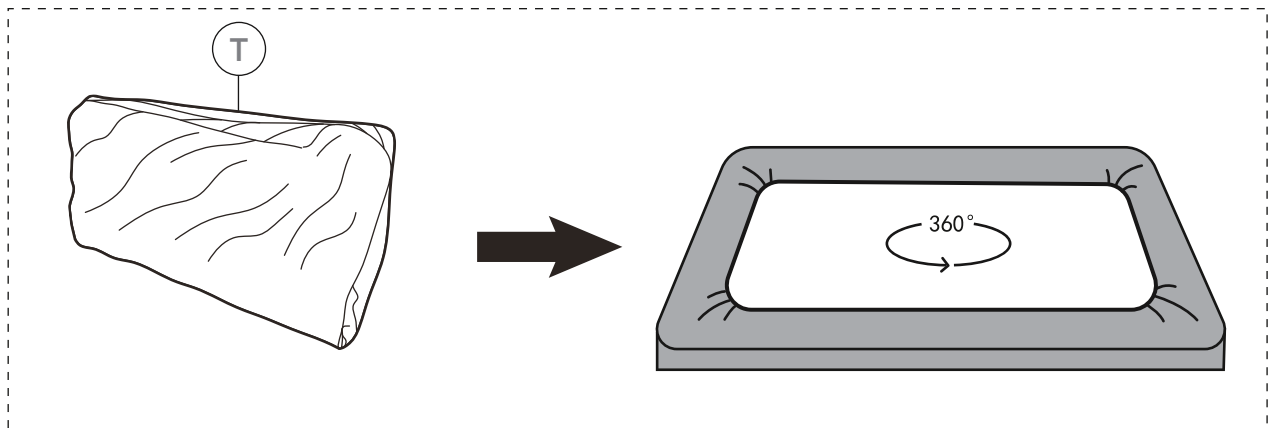

\*Remove the sham, unfold it, and slip it over the end board to adhere to the Velcro on the back of the foot board.

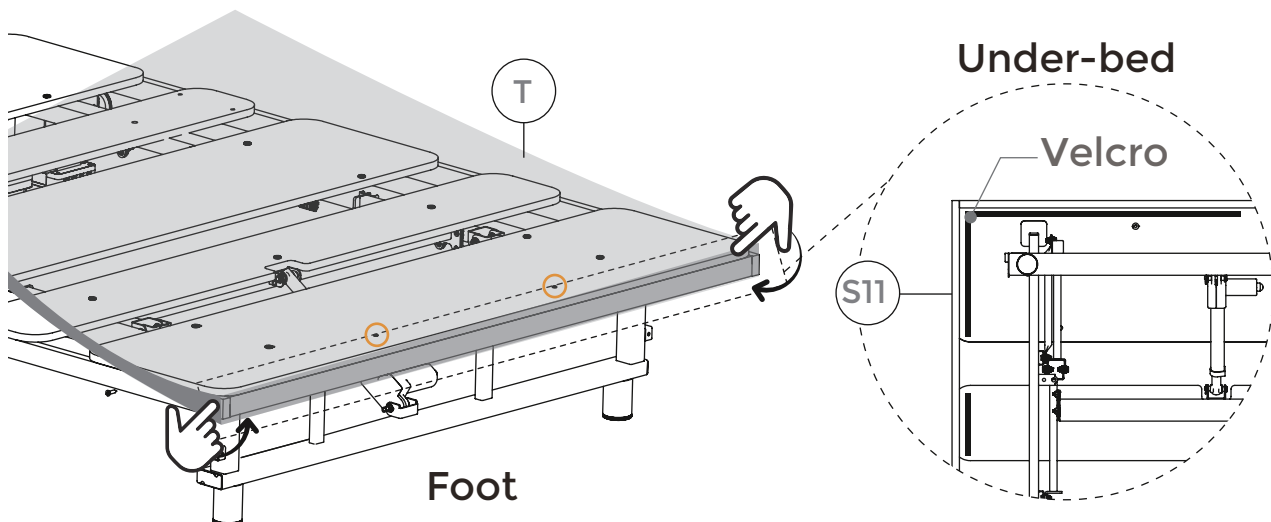

**Note:** The perforations on the sham are for the feet.

\*Pull-up bedspreads that attach to the side panels with Velcro.

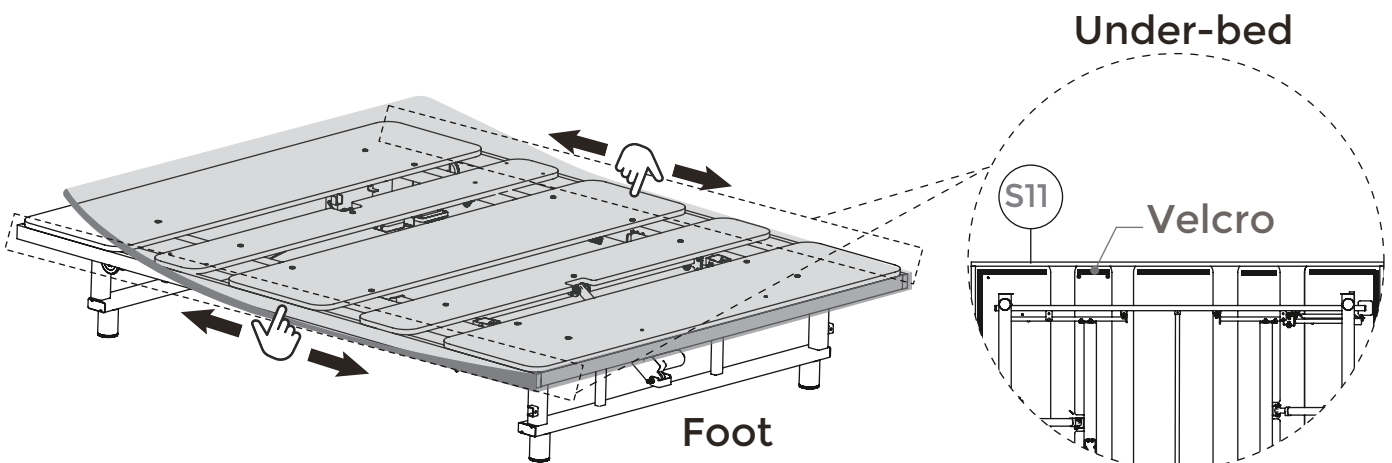

# Put on The Cloth Cover

\*Pull the headboard up, over the bedspread and velcro it to the bottom of the bed.

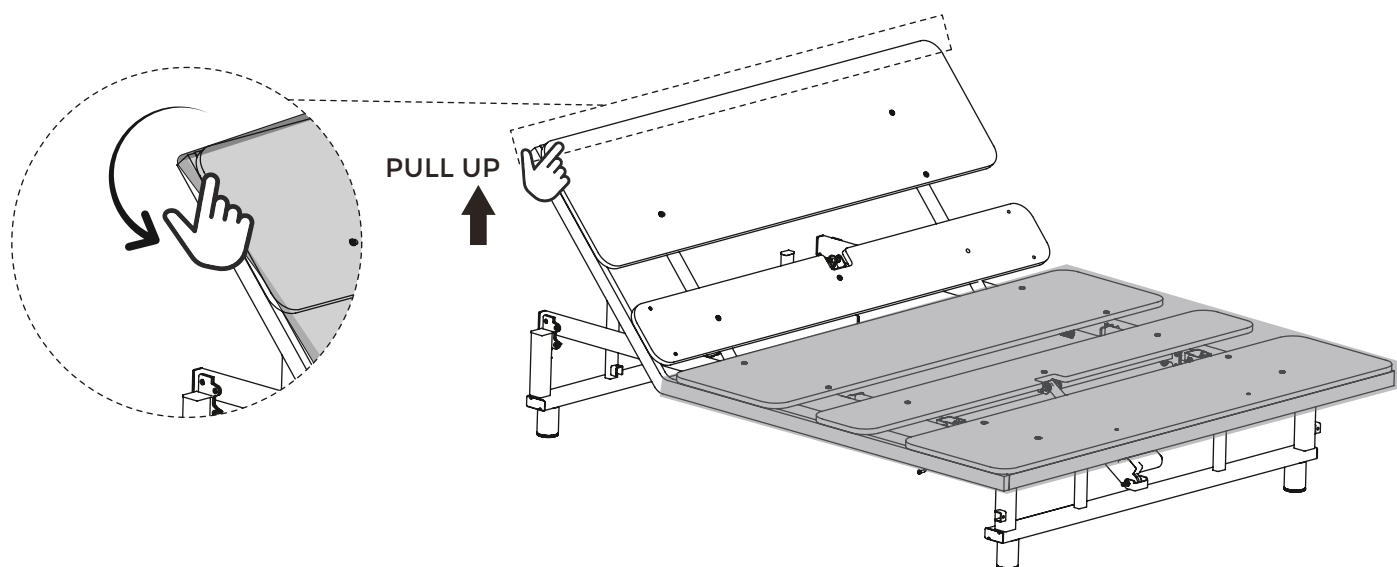

\*Lower the headboard and straighten the bedspread so that it fits flat.

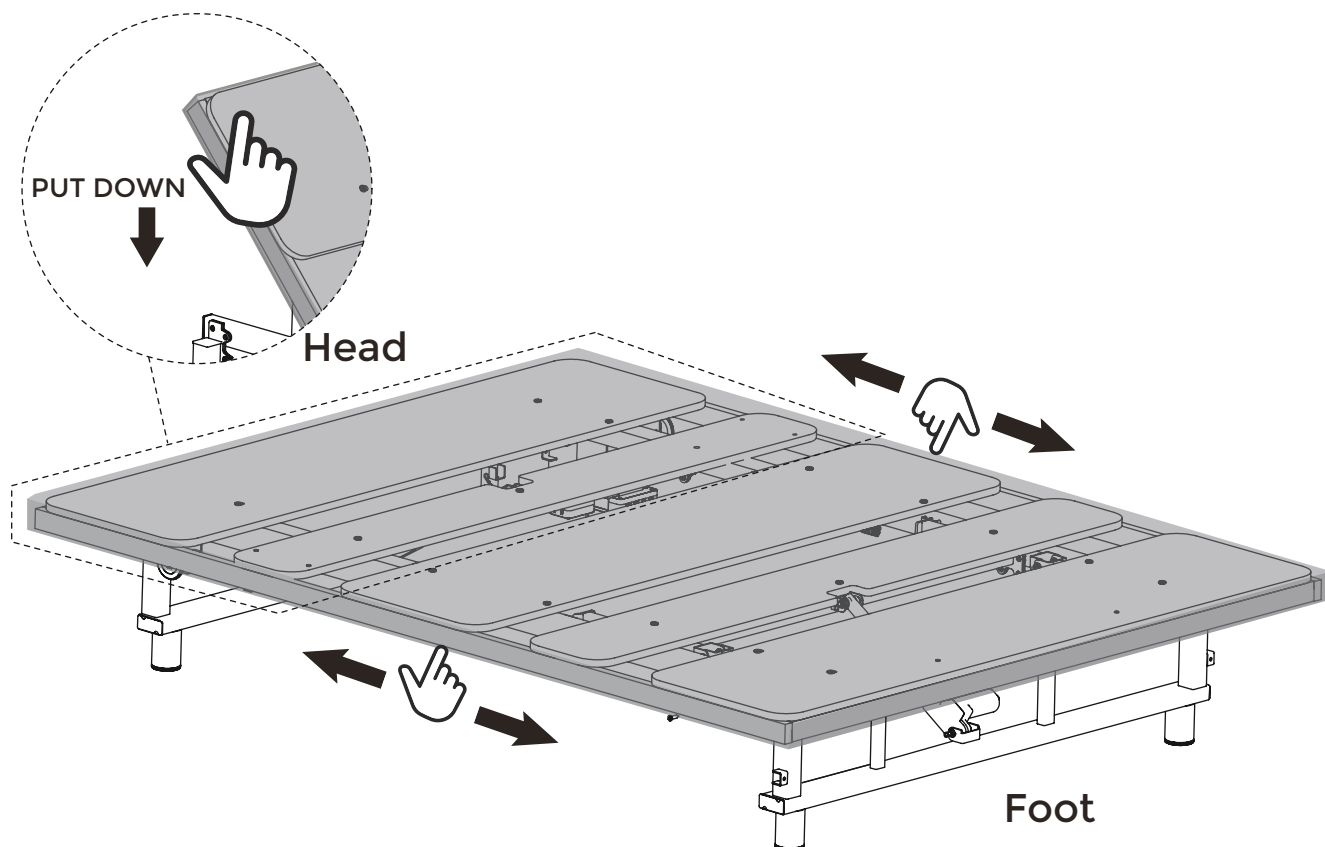

# Put on The Cloth Cover

## 2 Installation of mattress stopper.

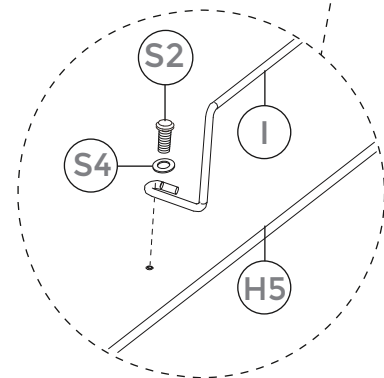
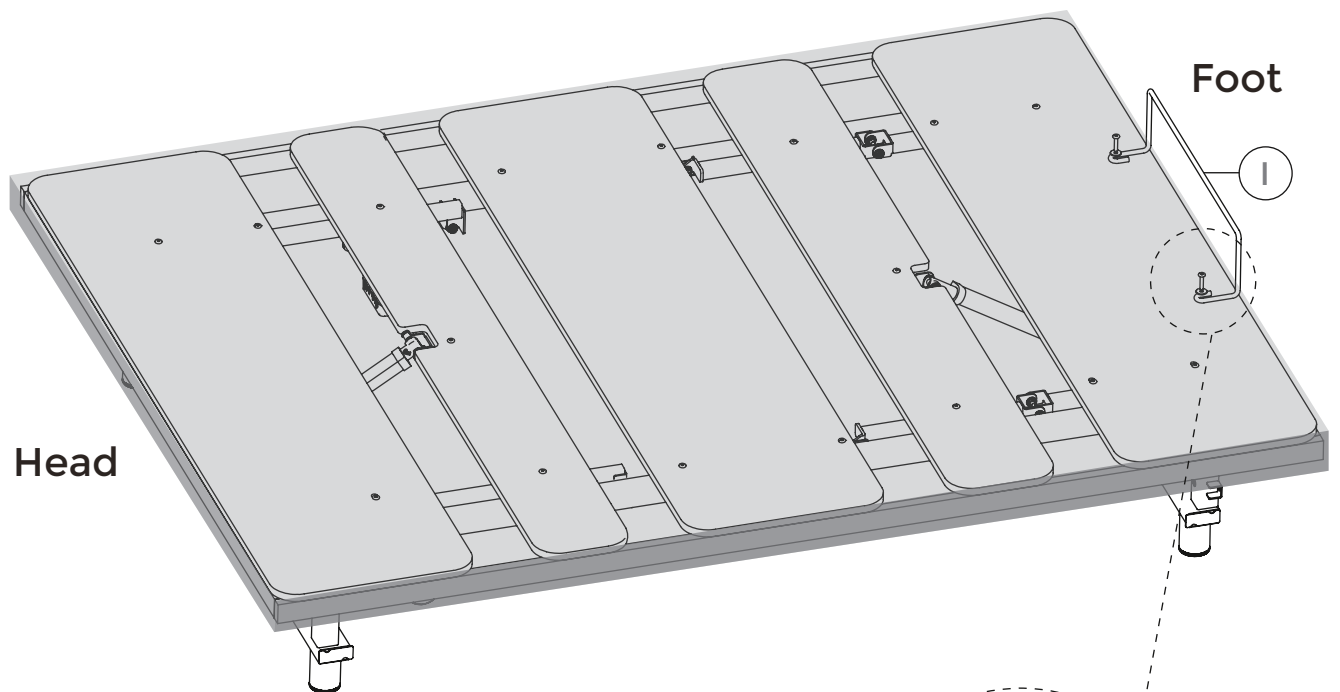

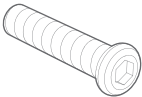
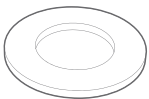
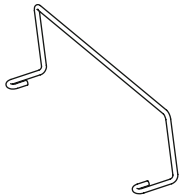
		
S2 2PCS	S4 2PCS	I 1PCS

# Connecting Straps (optional)



K4 (optional) for small size beds only.

- 1** With the bases in their desired location, slightly loose both legs to allow the strap to fit on the leg bolt between the leg washer and frame.

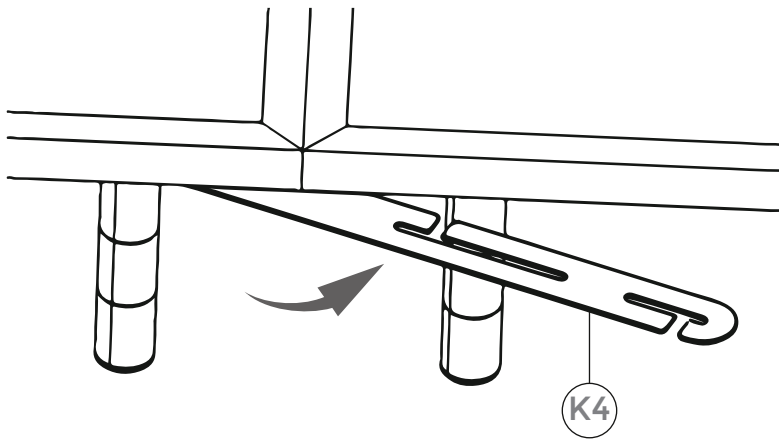

- 2** Slide side (a) of the connecting strap(K4) onto leg bolt. Swing the strap and connect side (b) to the leg bolt. Secure the strap by shifting to the left.

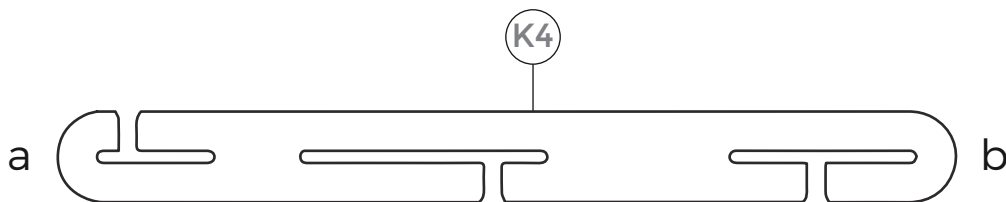

- 3** Re-tighten legs. Do not over tighten. Use the remaining strap and repeat on other end of the base.

# Syncing Two Bases

**STEP 1:** Unplug bases from power source.

**STEP2:** Connect the Sync Cord to the Multifunction port of each Control Box.

**STEP3:** Plug bases back into the power source.

**STEP4:** Check to ensure all cords are securely attached, and you can use the paired remote to control the two beds.



**K3 for small size beds only.**

**Control Box 1**

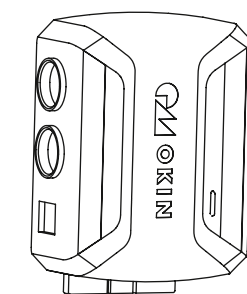
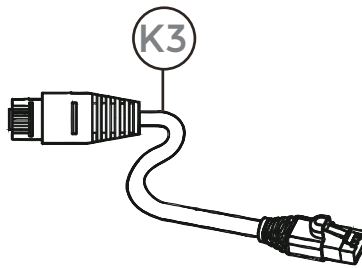
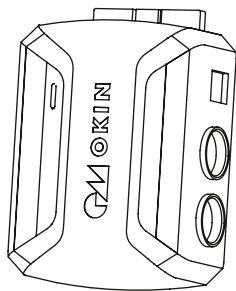

**Control Box 2**



If bases become mismatched, pressing the FLAT button will re-sync the mechanical positions.

# Warning



Notice: Please don't focus the weight on head or foot of bed. Please avoid sitting on either end of your bed after it has been lifted.

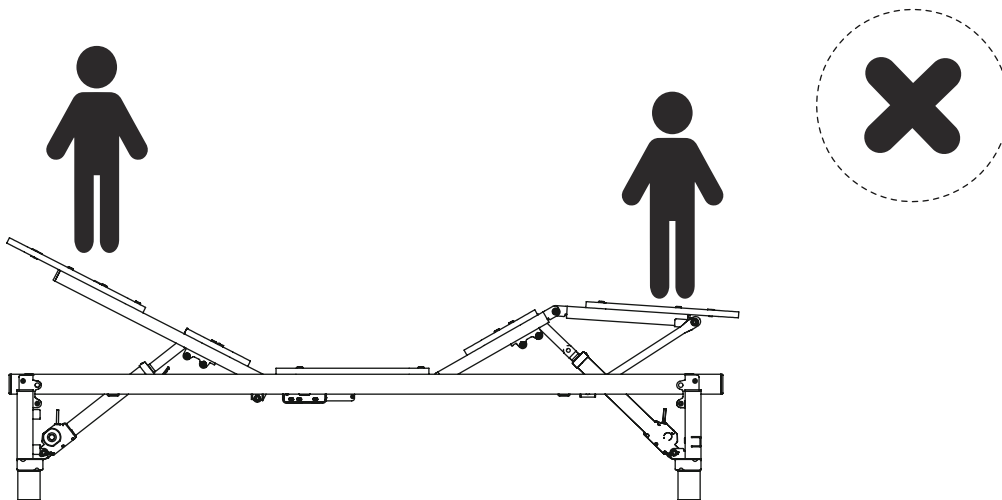
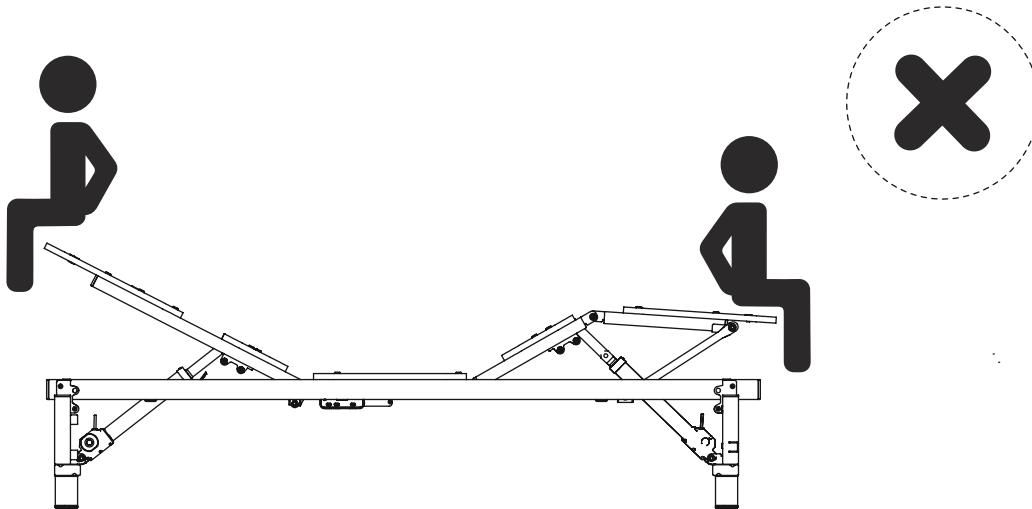
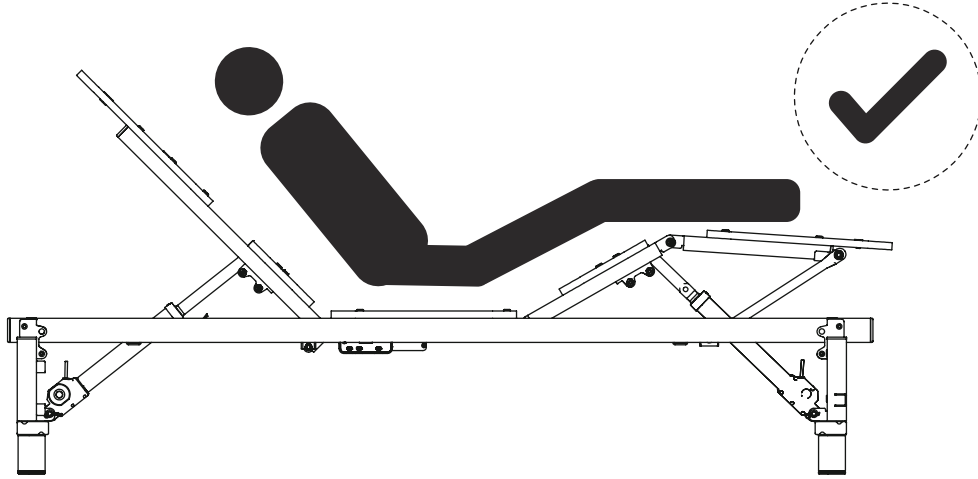

# Remote Control

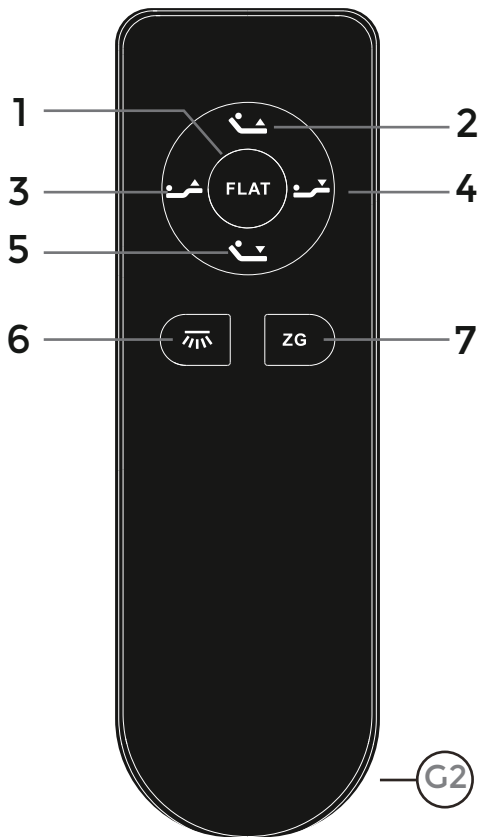

- 1: Flat
- 2: Head up
- 3: Foot up
- 4: Foot down
- 5: Head down
- 6: Underbed-light
- 7: Zero-G

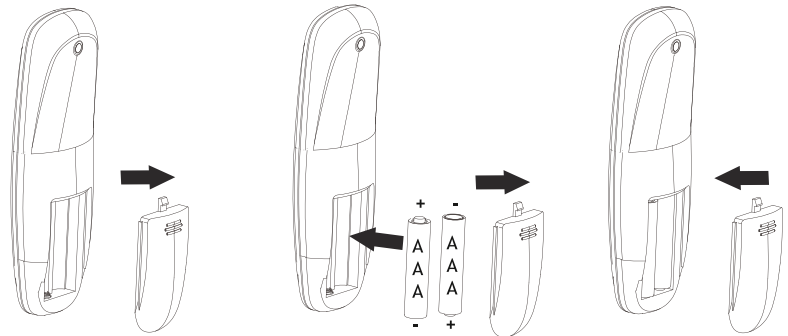

Please install the battery as shown, pay attention to the battery polarity.

## Pairing

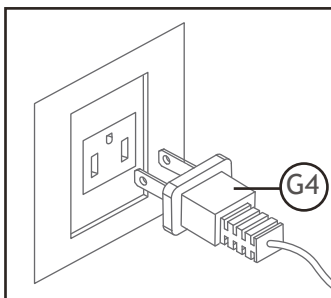

Pairing mode

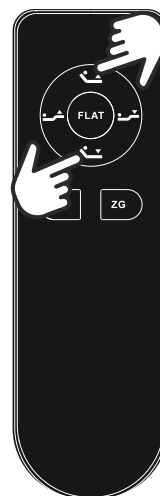
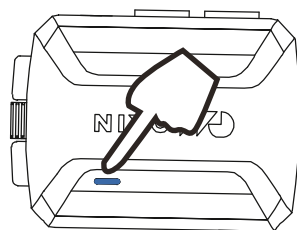

Normal state

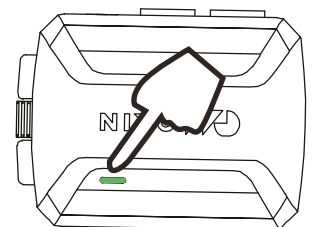

1. Unplug the power cord, power on after 5s, the control box indicator turns blue, and the control box enters the pairing mode.
2. Simultaneously press and hold the remote control "head up + head down" button, the backlight of the remote control will flash, and the remote control will enter into the pairing mode. until the remote control backlight stops flashing and is always on, the control box indicator light turns green, pairing is completed.

# Troubleshooting

The bed is unable to operate	Power supply check	The power is not plugged in	Please plug it in to restore power and check the socket has power.
		The power is damage	Visually inspect whether the green indicator light on the power adapter is illuminated, if the power supply still does not turn on, it is likely damaged Please replace the power supply.
		The AC/DC cable is not connected	Refer to the instruction manual and check if the AC/DC cable is connected correctly, if the connections are not accurate, please refer to the instruction manual and make the necessary adjustments.
	Remote control check	The power supply battery is not installed	Check if the battery is installed, if the battery is not installed, please proceed with the installation of the battery.
		The battery is installed in reverse polarity	Check if the battery is installed in the correct orientation,ensure that the battery is correctly installed.
		The battery is depleted or has no charge	Check if the battery has sufficient charge, replace the battery with a new and functional one.
		The remote control is not paired	Pressing the remote control function key does not elicit any response from the bed, follow the instructions in the manual to re-pair the devices.
		The remote control is damaged	After successfully re-pairing, the bed still does not respond, replace the remote control with a new one.
		The main control box is experiencing an abnormality	Re-pairing was unsuccessful, troubleshoot the main control box.
	Main control box check	The DC cable is not connected	Visually inspect whether the indicator light on the main control box is illuminated If it is not lit, troubleshoot by checking if the DC cable is properly connected, connect the DC cable to the control box following the electrical diagram in the instruction manual.
		The DC cable is connected	Visually inspect whether the indicator light on the main control box is illuminated If it is not lit, troubleshoot by checking if the DC cable is properly connected.
		The indicator light on the main control box is illuminated	Visually inspect whether the indicator light on the main control box is illuminated If the light is on, it indicates that the power supply is functioning , troubleshoot the motor.
	Motor check	The motor is not connected	Visually inspect whether the motor is plugged into the main control box, connect the motor to the main control box following the electrical diagram in the instruction manual.
		The motor port is connected incorrectly, Remote control button does not match motor run	Check if the motor is properly connected to the correct interface on the main control box.Please ensure that the labels on the motor match the names of the ports on the main control box.
		The bed is unable to raise or lower	Pressing the up/down button on the remote control to raise/lower the bed,the motor is malfunctioning Please replace the motor with a new one.

-----

1K80000075  
V01-06-2024