

ASSEMBLY INSTRUCTIONS

MODEL : WM2007-DT

IMPORTANT NOTE :

- * PLACE ALL WOODEN PARTS ON A CLEAN AND SMOOTH SURFACE SUCH AS A RUG OR CARPET TO AVOID THE PARTS FROM BEING SCRATCHED.
- * BEFORE YOU BEGIN, KINDLY FOLLOW THE ASSEMBLY INSTRUCTIONS STEP BY STEP.

HARDWARE LIST		
A	JCBB M8 x 60mm + S/W 5/16" + F/W 5/16" x 22mm	16PCS
B	JCBC M6 x 40mm + S/W M6 + F/W M6 x 13mm	16PCS
C	ALLEN KEY M5	1PC
D	ALLEN KEY M4 (BALL SHAPE)	1PC

PART LIST		
1	TABLE TOP	1PC
2	TABLE LEG	16PCS
3	BASE FRAME	2PCS
4	WEIGHTED PANEL	2PCS

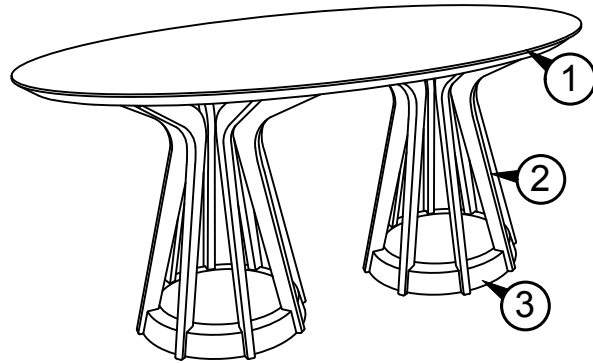

COMPLETED TABLE ASSEMBLY.

STEP 1 BEFORE ASSEMBLY PLEASE LOOSEN THE JCBC M6 x 40MM WITH SPRING AND FLAT WASHER (6PCS) TO TAKE OUT THE WEIGHTED PANEL (4).

*PLEASE KEEP JCBC BOLT TO FIX WEIGHTED PANEL (4) INTO THE BASE FRAME (3) AT STEP 5

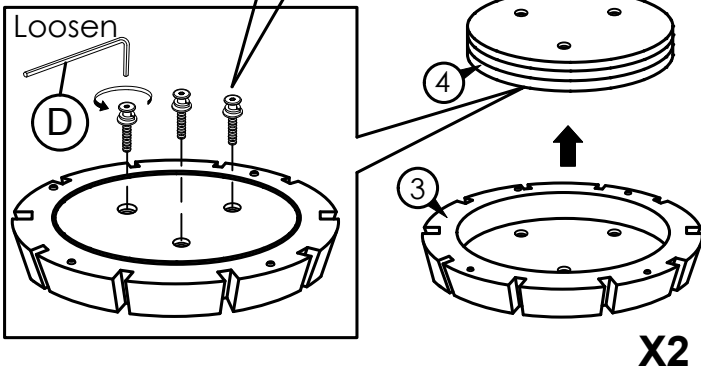

STEP 2

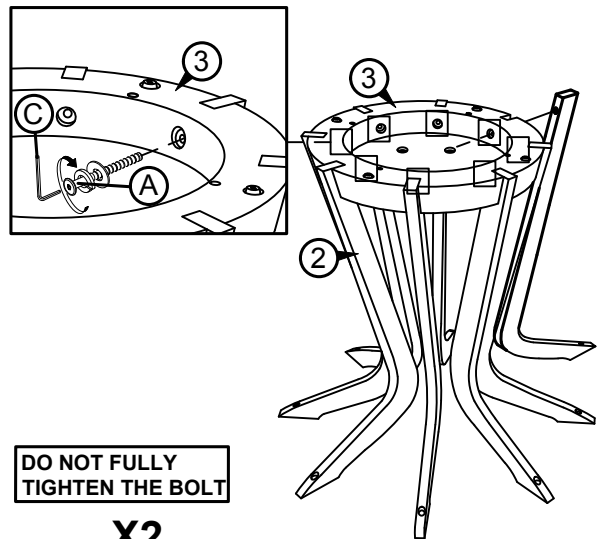

STEP 3

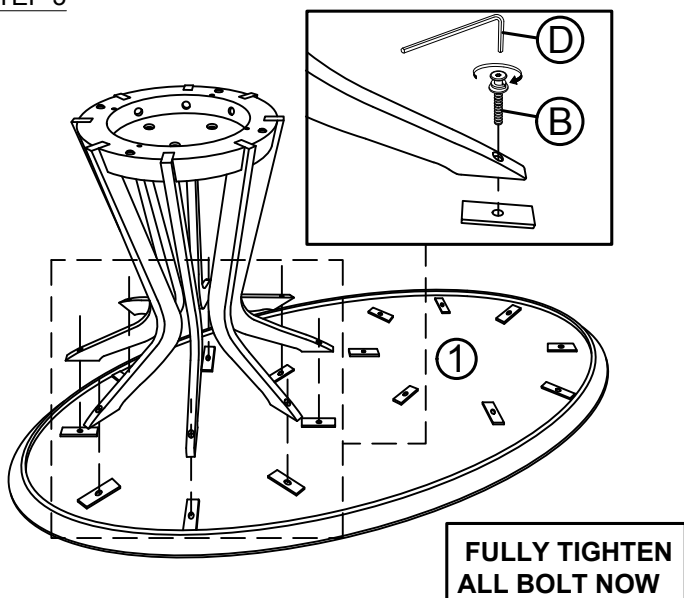

STEP 4

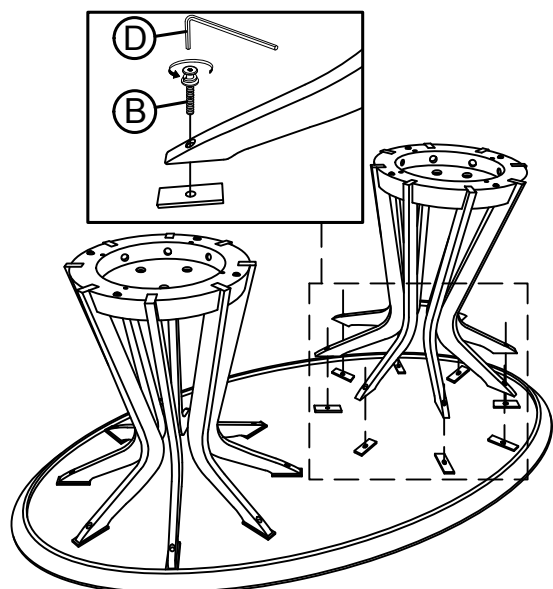

ASSEMBLY INSTRUCTIONS

MODEL : WM2007-DT

STEP 5

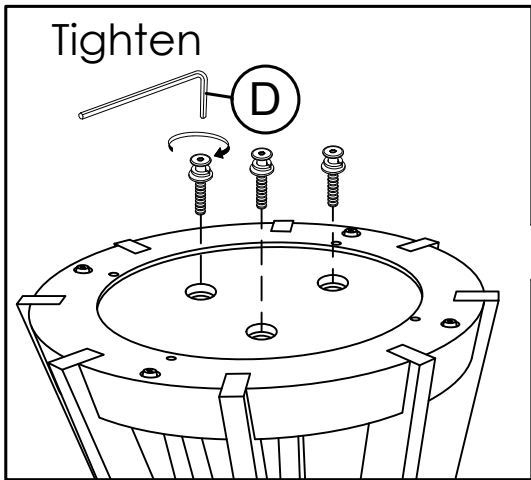

PLEASE FIX THE WEIGHTED PANEL (4) INTO THE BASE FRAME (3) AND TIGHTEN USING JCBC M6 x 40MM WITH SPRING AND FLAT WASHER (6PCS)

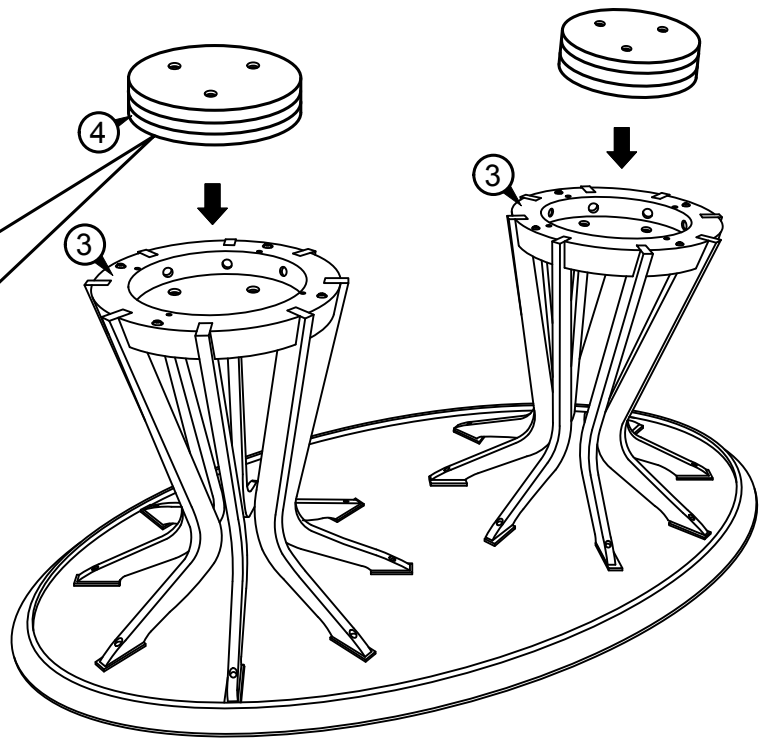

STEP 6

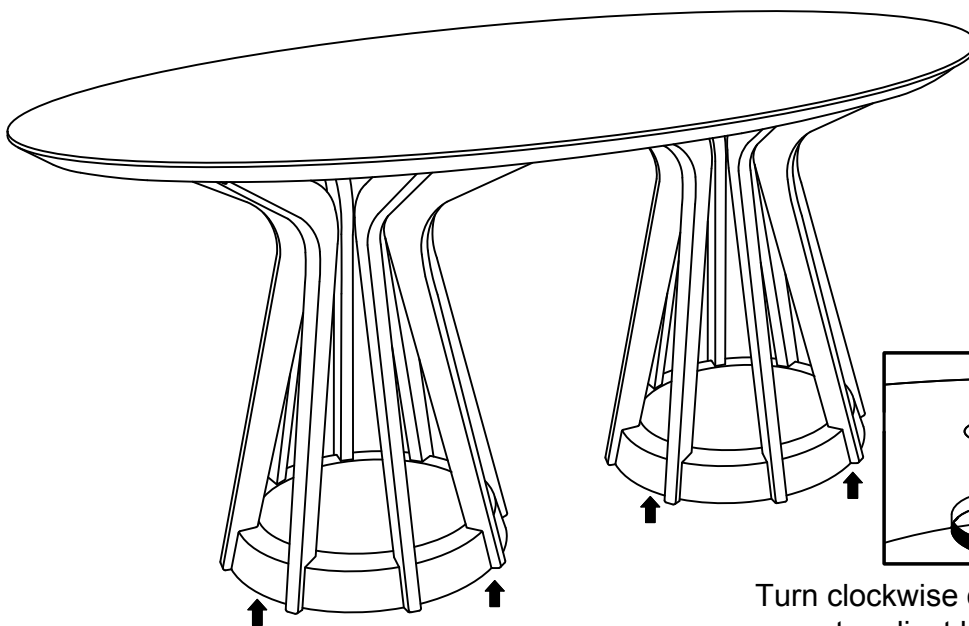

Turn clockwise or anti-clockwise to adjust leg leveller.