

Rodeo Elite Charcoal Grill

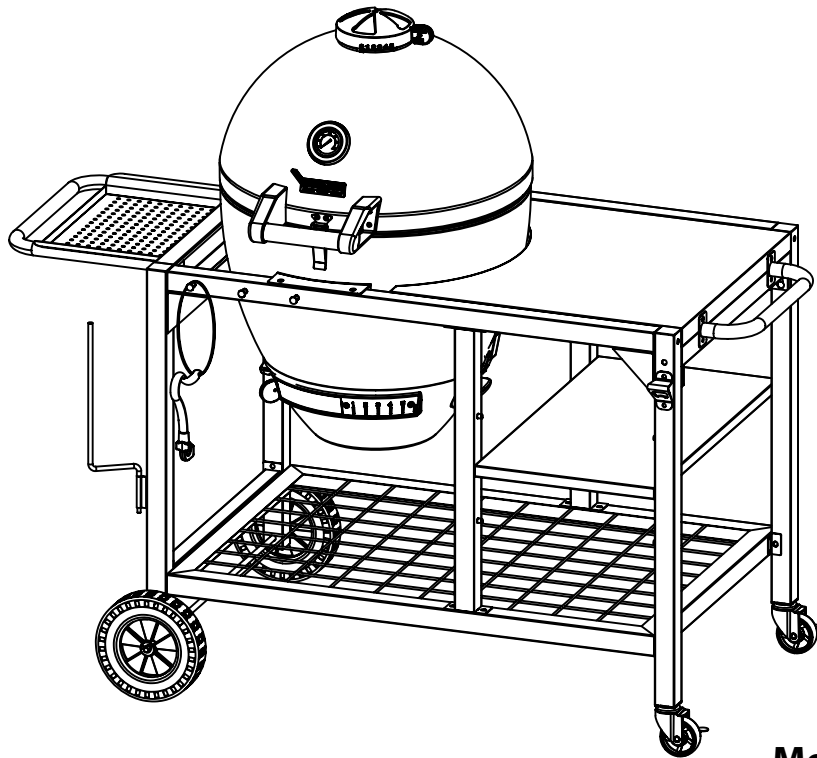

Model: BG2450A0

Product Code: BMRDOELT

Important: Keep this Owner's Manual for convenient reference and for part replacement.

Read this Owner's manual carefully and be sure your gas grill is properly assembled, installed and maintained. Failure to follow these instructions could result in serious injury and/or property damage.

Please make sure the cylinder valve connection device shall properly and safely connect with the connection device attached to the inlet of the pressure regulator.

For Outdoor Use Only

Captivate Brands USA, Inc.
25541 Arctic Ocean Drive,
Lake Forest, CA.92630

If you have any questions or problems, you can contact our customer service at 1-855-200-8445 ext 102 or service@brandmangrill.com from 9:00 AM - 5:00 PM Monday to Friday. (Pacific). All emails and voice-mail calls will be answered within 24 hours.

IMPORTANT HEALTH & SAFETY INFORMATION

1. WARNING

FOR OUTDOOR USE ONLY! DO NOT USE INDOORS

- Please read these instructions carefully prior to assembly and use.
- Failure to follow these instructions could lead to serious injury and/or significant damage to property.
- Do not start the barbeque if there is any doubt over the correct assembly, ignition, gas control or cooking of the unit.
- These instructions should be retained for future reference.
- The barbeque must have a minimum side clearance and back clearance from any combustible material of at least 1000mm. Additionally there must be a clearance of at least 2000mm above the cooking surface of the barbeque.
- Flammable materials and liquids must be stored well away from the barbeque.
- Aerosols must not be used near the barbeque.
- The barbeque should not be moved when lit or hot.
- A lit barbeque should be attended at all times.
- Avoid dousing the barbeque with water.
- Always allow the barbeque to completely cool down before covering.
- For safety reasons it is advisable to keep a fire extinguisher and fire blanket close to hand.
- Unsupervised children, elderly and infirm should not be allowed close to the barbeque during pre-heat, cooking, burn off or cooling down of the unit.
- Please dispose of all polythene packing and plastic bags carefully and keep out of the reach of children.

SETTING UP THE BARBECUE

THIS APPLIANCE SHALL ONLY BE USED IN AN ABOVE GROUND OPEN AIR SITUATION WITH NATURAL VENTILATION, WITHOUT STAGNANT AREAS, WHERE GAS LEAKAGE AND PRODUCTS OF COMBUSTION ARE RAPIDLY DISPERSED BY WIND AND NATURAL CONVECTION

1. POSITIONING

- Please make sure that the barbecue is NOT positioned underneath any combustible material or surface.
- There MUST be a clearance of at least 250mm from the sides of the barbecue to any combustible materials or surfaces. There must also be a clearance of at least 1500mm above the cooking surfaces to any combustible surface, and 500mm clearance at the back.
- Flammable materials of any description MUST be kept well away from the barbecue.
- The barbecue must be positioned such that the gas cylinder is kept away from direct sunlight.
- The barbecue must be positioned to avoid walkways, gangways and general pedestrian access.
- The nature of a barbecue is such that many of the surfaces are hot to touch, the positioning of the barbecue should take into consideration the possibility of accidental hand or body contact.

Any enclosure in which the appliance is used shall comply with one of the following:

- An enclosure with walls on all sides, but at least one permanent opening at ground level and no overhead cover.
SEE EXAMPLE 1
- Within a partial enclosure that includes an overhead cover and no more than two walls.
SEE EXAMPLE 2 & 3
- Within a partial enclosure that includes an overhead cover and more than two walls, the following shall apply-
 - at least 25% of the total wall area is completely open; and
 - at least 30% of the remaining wall area is open and unrestricted
SEE EXAMPLE 4 & 5
- In the case of balconies, at least 20% of the total of the side, back and front wall areas shall be and remain open and unrestricted

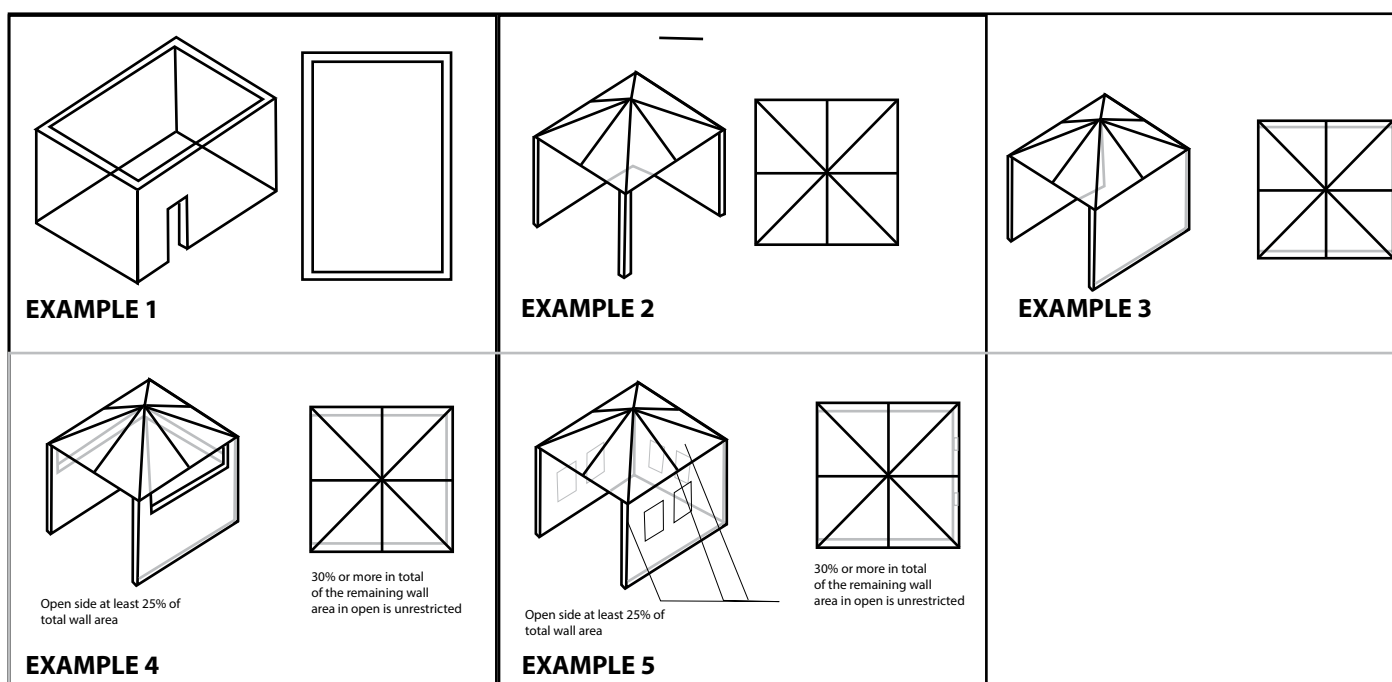
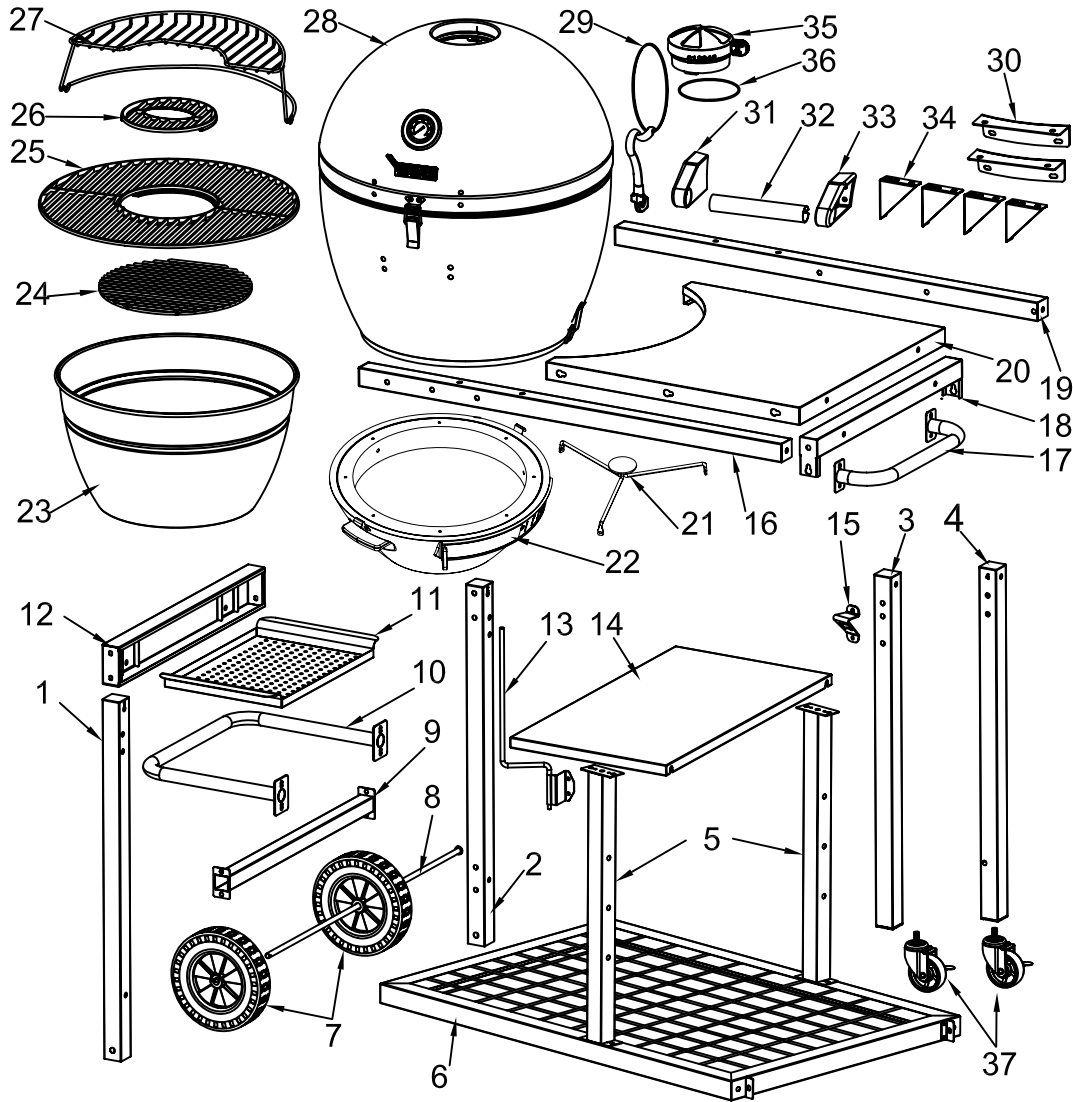

Table of Contents

Important Health & Safety Information-----	2
Setting Up The Barbecue-----	3
Table of Contents-----	4
Parts Diagram-----	5
Parts List-----	5
Hardware -----	6
Tools Required for Assembly-----	6
Assembly Steps -----	7-14
Operating Instructions -----	15-17
Cleaning and Care -----	18









Parts Diagram



Parts List

Part	Description	QTY	Part	Description	QTY	Part	Description	QTY
1	Left Front Leg	1pc	14	Middle Shelf	1pc	27	Warming Rack	1pc
2	Left Rear Leg	1pc	15	Bottle Opener	1pc	28	Body and Lid Assembly	1pc
3	Right Front Leg	1pc	16	Front Upper Rail	1pc	29	Lifting Handle	1pc
4	Right Rear Leg	1pc	17	Right Handle	1pc	30	Body Support	2pcs
5	Middle Brace	2pcs	18	Right Upper Rail	1pc	31	Handle Base - Left	1pc
6	Bottom Shelf	1pc	19	Rear Upper Rail	1pc	32	Lid Handle	1pc
7	Wheel	2pcs	20	Upper Shelf	1pc	33	Handle Base - Right	1pc
8	Axle	1pc	21	Ash Pan Holder	1pc	34	Bracket	4pcs
9	Left Bottom Rail	1pc	22	Ash Pan	1pc	35	Damper	1pc
10	Left Shelf Supporter	1pc	23	Fire Bowl	1pc	36	O-ring	1pc
11	Left Shelf	1pc	24	Charcoal Grid	1pc	37	Caster	2pcs
12	Left Upper Rail	1pc	25	Cooking Grid Outer	1pc			
13	Tissue Holder	1pc	26	Cooking Grid Inner	1pc			

Hardware

Part #	Description		QTY
A	Bolt(M6*15)		74PCS
B	Bolt(M6*50)		6PCS
C	Flat Washer($\Phi 6.2 \times \Phi 12 \times 0.8$)		36PCS
D	Spring Washer($\Phi 6.2$)		36PCS
E	Wheel pad ($\Phi 18 \times \Phi 12 \times 10$)		2PCS
F	Split Pin		1PCS
G	Bolt(M6*24)		3PCS
H	Bolt(M4*12)		5PCS
J	Bolt(M6*15)		12PCS

Tools Required for Assembly

Philips Head Screwdriver (not included)

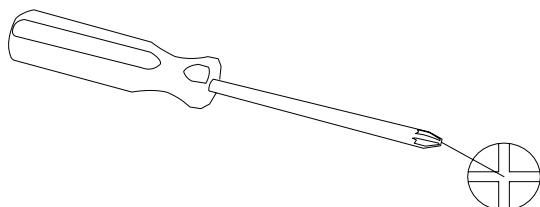

Step 1

- Starting with the left leg, attach the Left Upper Rail (12) between Left Front Leg (1) and Left Rear Leg (2) with two spring washers (C), two flat washers (D) and two bolts (A) on each side as shown below.
- Secure further the left leg with Left Bottom Rail (9) with four bolts (A) as shown.
- Continue onto the right side by securing the Right Upper Rail (18) onto the Right Front Leg (3) and Right Rear Leg (4) with two spring washers (C), two flat washers (D), two Bolts (B) and two Bolts (A) as shown below.
- Screw on the two Caster(37) onto each of the right leg as shown.
- Ensure all screws are tightened.

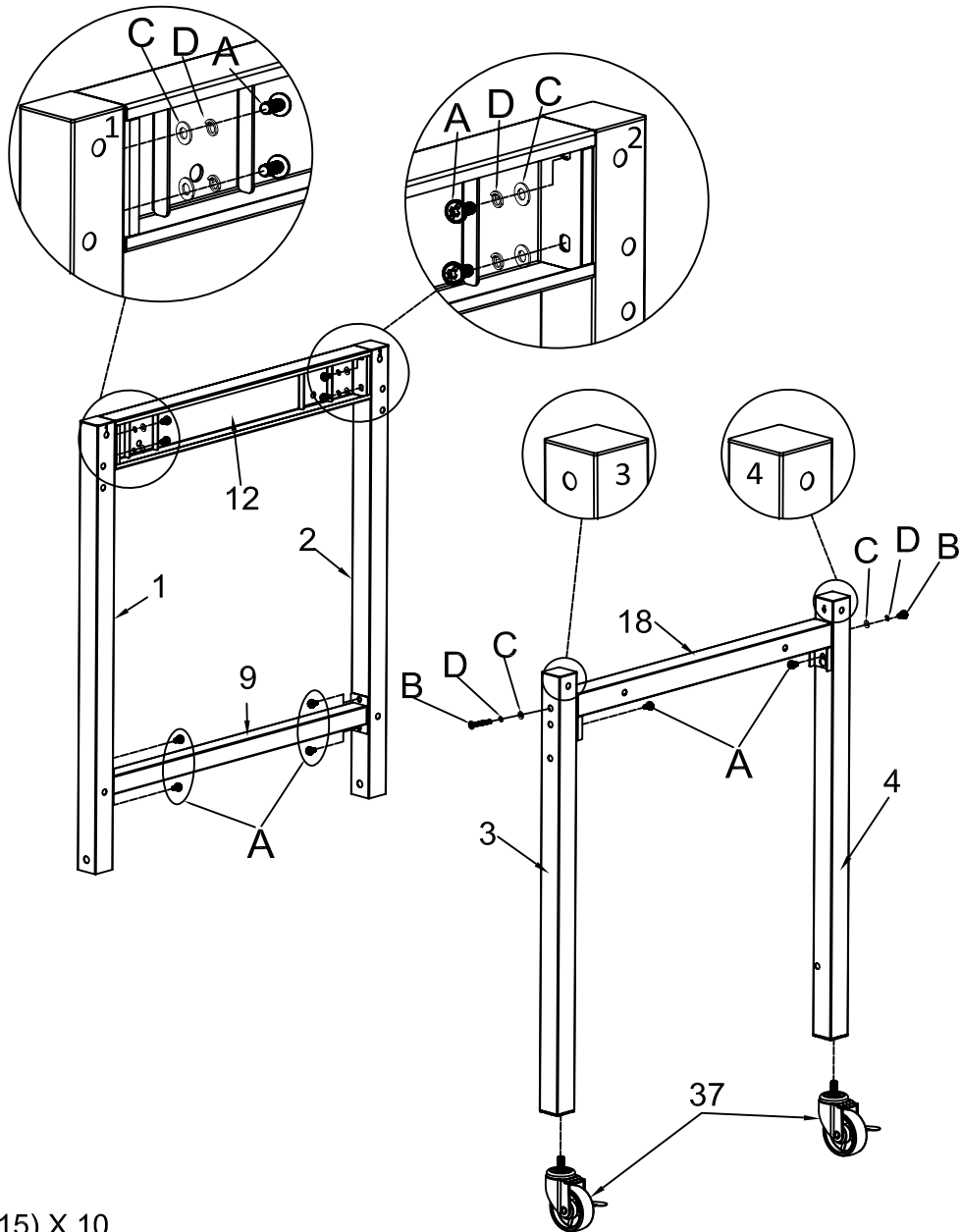

A  (M6*15) X 10

B  (M6*50) X 2

C  (Φ6.2*Φ12*0.8) X 6

D  (Φ6.2) X 6

Step 2

- Install the Bottom Shelf (6) onto the Left Leg and Right Leg prepared with ten bolts (A) accordingly as shown in the diagram below.
- After securing the Bottom Shelf (6), install one Middle Brace(5)at the center front of the Bottom Shelf with two bolts (A).
- Install another Middle Brace (5) at the center rear of the Bottom Shelf with two bolts (A).
- Screw on 6 bolts (J) between the front Middle Brace and Right Front Leg with 3 bolts (J)each side as shown.
- Repeat the same with the rear Middle Brace and Right Rear Legs.

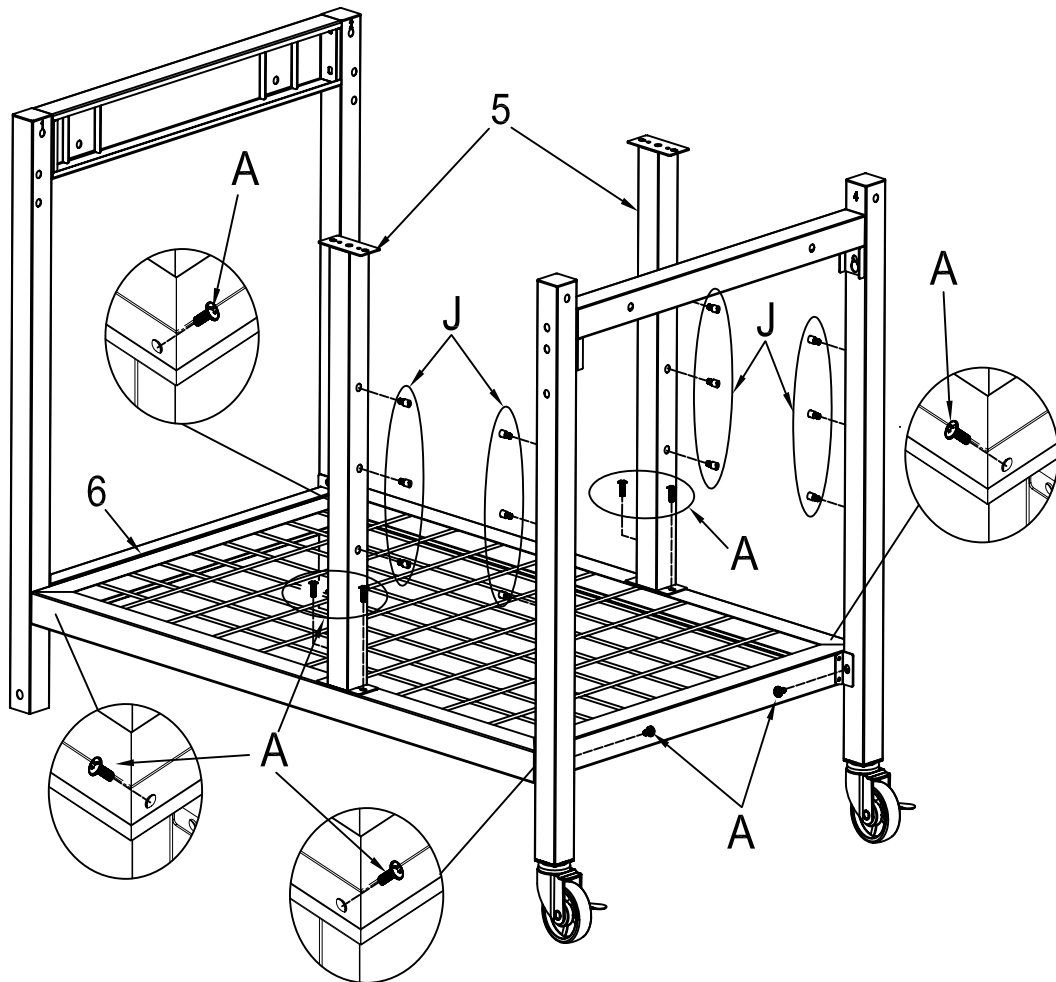





A  (M6*15) X 10

J  (M6*15) X 12

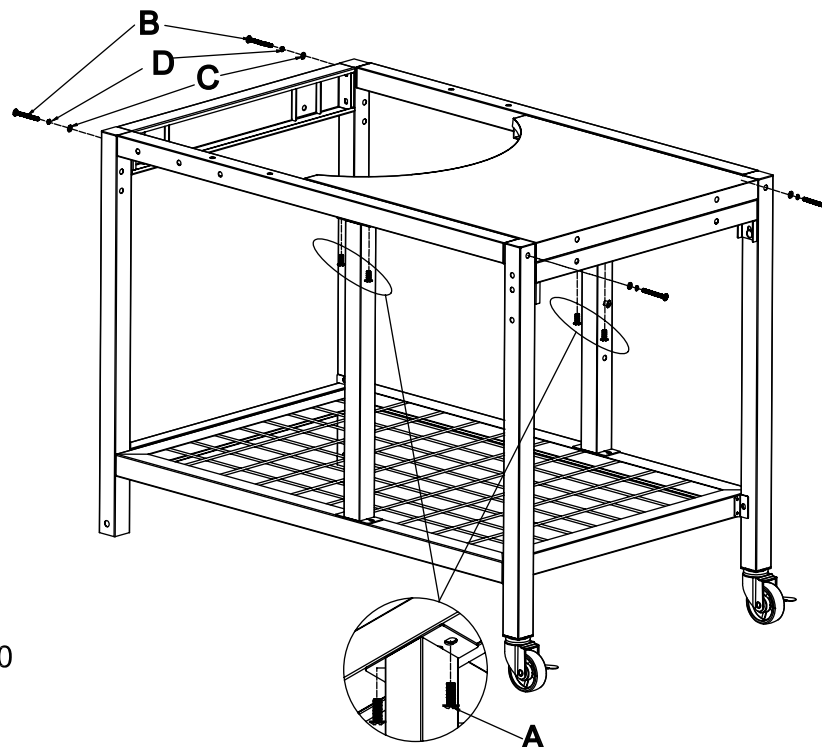
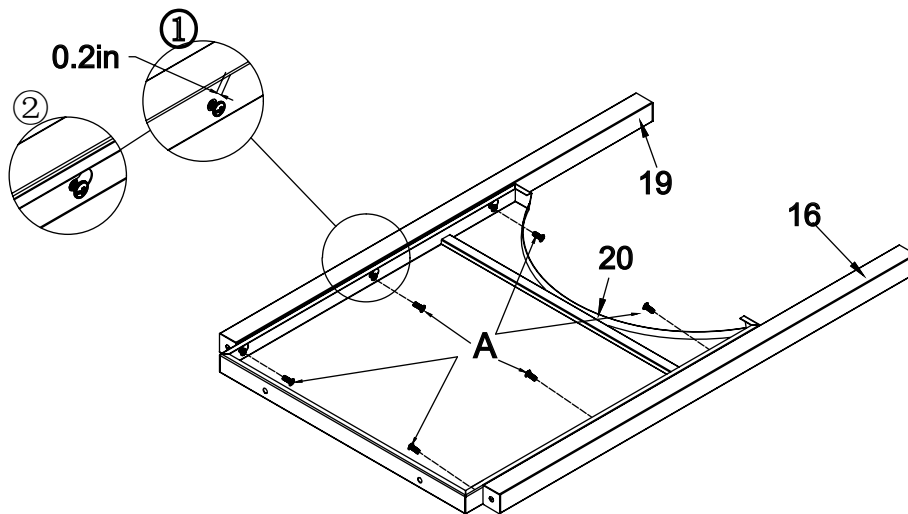
Step 3

- Screw on three bolts (A) onto each of the Front Upper Rail (16) and Rear Upper Rail (19) with leaving a 0.2in gap on each screw as shown in Figure 1 below.
- Hook in the Upper Shelf (20) onto the Front Upper Rail (16) and Rear Upper Rail (19) as shown in Figure 2. Tighten all the screws after the Front Upper Rail (16) and Rear Upper Rail (19).
- Put on the prepare cart top onto the cart leg prepared in Step 2 and secure it with a spring washer (C), a flat washer (D) and a bolt (B) on each side as shown below.
- Secure further the Middle Brace onto the cart top with two bolt (A) each Middle Brace.



- A  (M6*15) X 10
- B  (M6*50) X 4
- C  (Φ6.2*Φ12*0.8) X 4
- D  (Φ6.2) X4

Step 4

- Install the Bracket (34) onto the upper front and rear corner of the cart with four bolts (A) each as show below.
- Ensure all bolts are tighten properly.

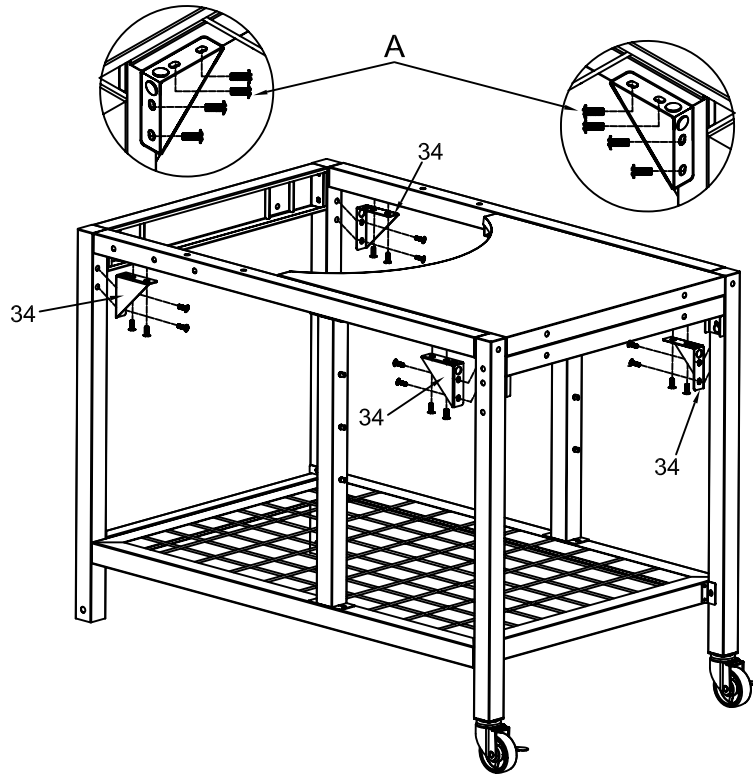

A  (M6*15) X16

Step 5

- Install the Left Shelf Supporter(10) onto the left side Left Upper Rail (12) with four flat washers (C), four spring washers (D) and four bolts (A) as shown.
- Continue install the Right Handle (17) onto the right side top cart with four flat washers (C), four spring washers (D) and four bolts (A) as shown.
- Attach on the Bottle Opener (15) onto Right Front Leg with two bolts (A).
- Attach the Tissue Holder (13) onto the rear side of the Left Front Leg (1) as shown and secure it with two bolts (H).
- At the front top left of the cart, screw on the hooks, which are the three bolts (G) as shown.

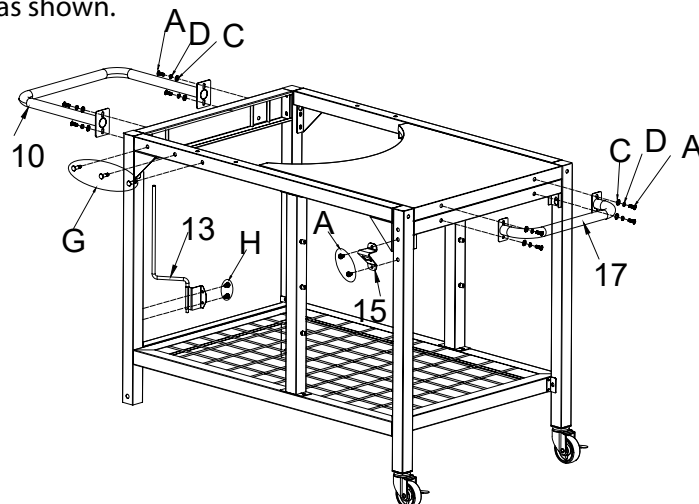

A  (M6*15) X 10

H  (M4*12) X 2

G  (M6*24) X 3

C  (Φ6.2*Φ12*0.8) X 8

D  (Φ6.2) X 8

Step 6

- Fit in Axle (8) onto the cart left leg as shown below.
- Then fit on one Wheel Pad (E) on each side before putting on the Wheel (7) on each side.
- Secure the Wheels with Split Pin (F) as shown below.

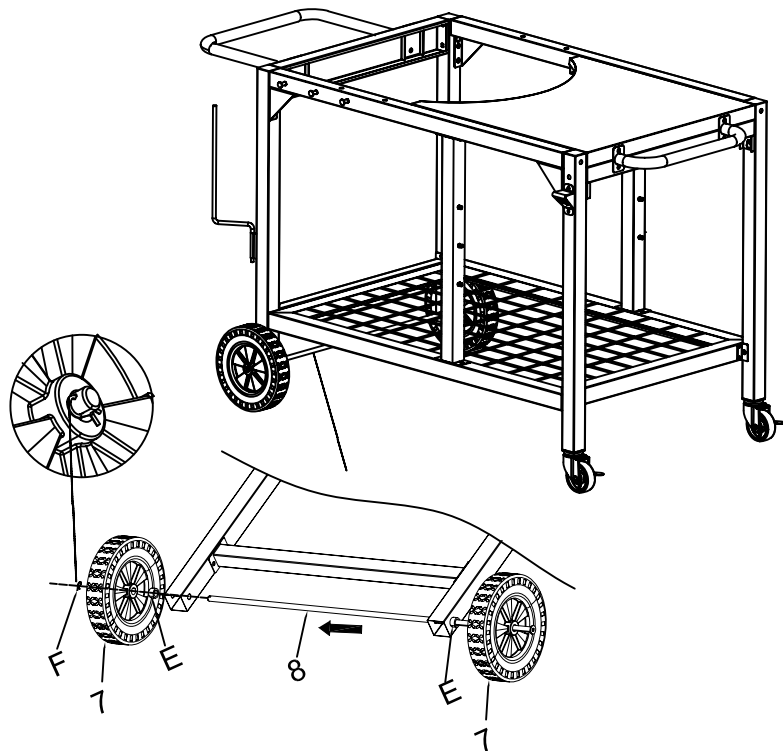

E  (Wheel pad) X 2

F  (Split Pin) X 1

Step 7

- Put on the Left Shelf (11) onto the Left Shelf Supporter installed as shown.
- Attach on the Middle Shelf (14) onto the cart in the level preferred as shown below.

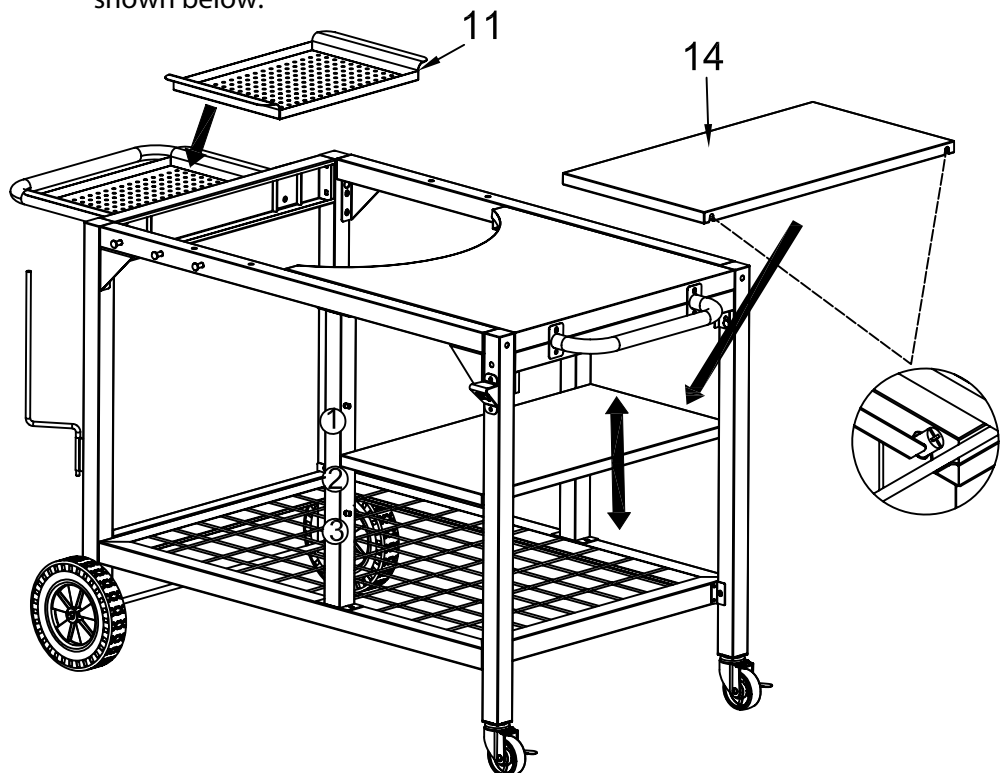

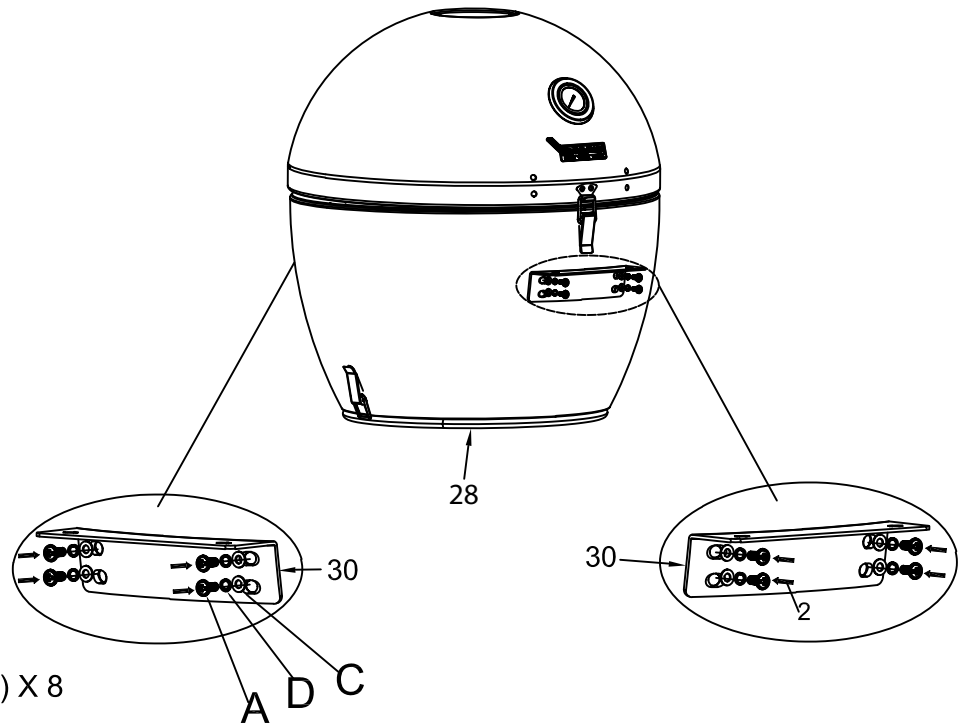

Step 8

- Install Body Support (30) on the front of the Body Assembly (28) with four Bolts (A), four Spring Washers (D) and four Flat Washers (C) as shown below.
- Repeat the same step at the back of the Body Assembly with another Furnace Body Support (30).



A  (M6*15) X 8

C  (Φ6.2*Φ12*0.8) X 8

D  (Φ6.2) X 8

Step 9

- With the help of another person, put on the body assembly prepared in Step 8 onto the prepared cart in Step 7.
- Secure the Body Assembly (28) front and back with two Bolts (A), two Spring Washers (D) and two Flat Washers (C) each as shown below.

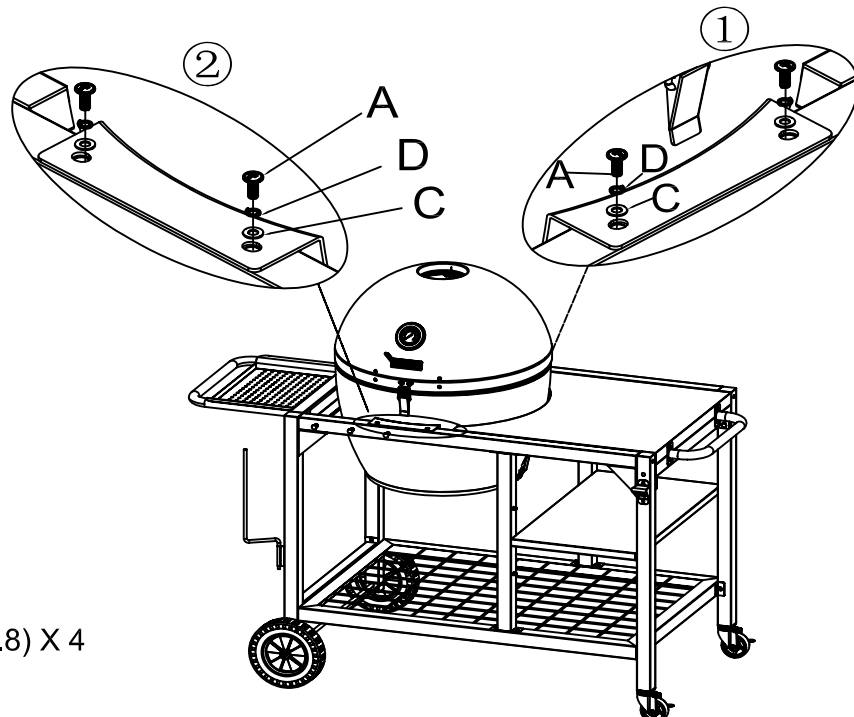

A  (M6*15) X 4

C  (Φ6.2*Φ12*0.8) X 4

D  (Φ6.2) X 4

Step 10

- Install on the Handle Base - Left (31), Lid Handle (32) and Handle Base - Right (33) together onto the front of the hood with four Bolts (A), four Spring Washers (D) and four Flat Washers (C) as shown below.
- Ensure all screws are tightened.

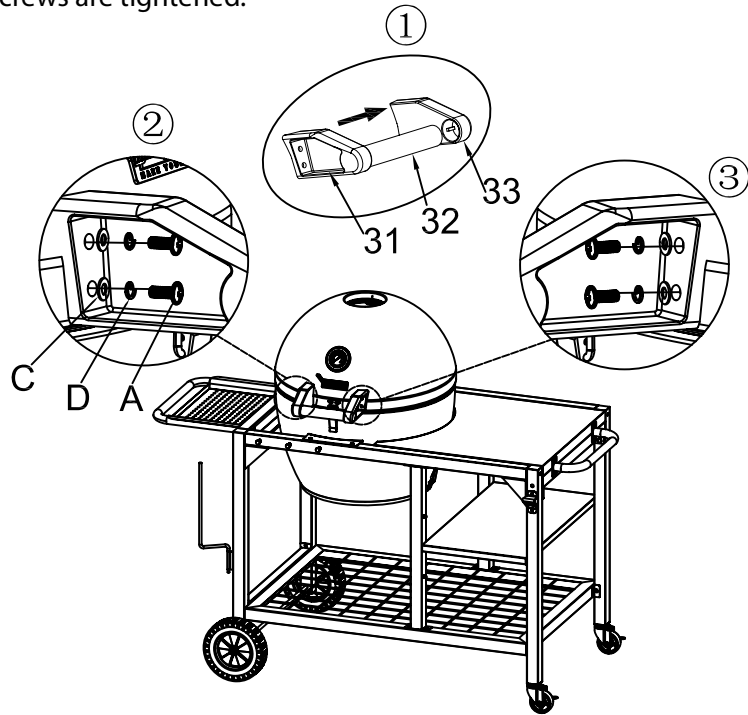

A  (M6*15) X 4

C  (Φ6.2*Φ12*0.8) X 4

D  (Φ6.2) X 4

Step 11

- With the hood open, install on the Damper (35) and O-ring Seal (36) with two Bolts (A), two Spring Washers (D) and two Flat Washers (C) as shown below.

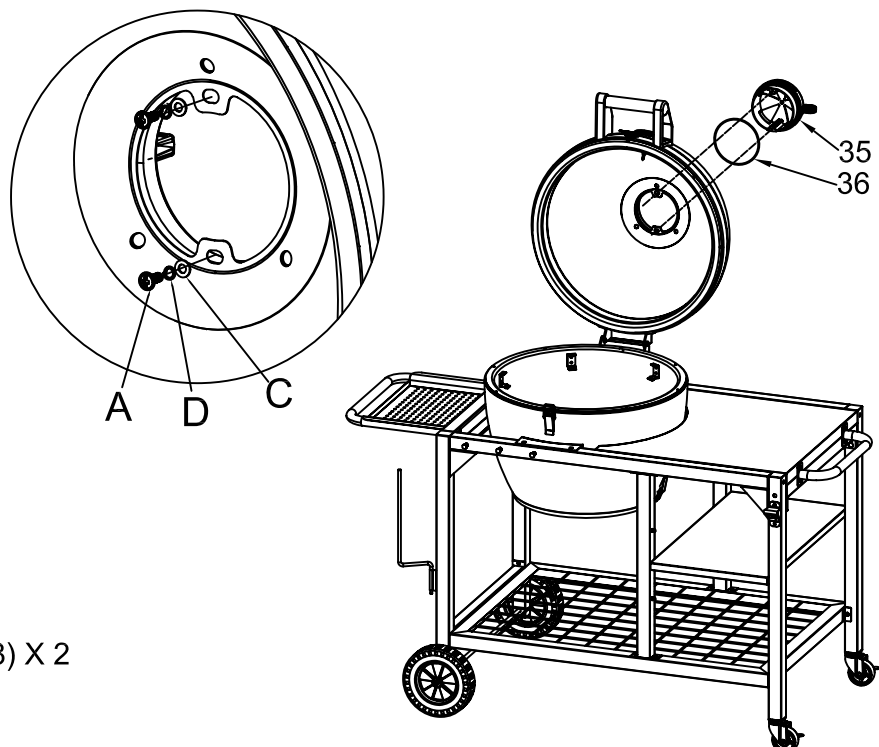

A  (M6*15) X 2

C  (Φ6.2*Φ12*0.8) X 2

D  (Φ6.2) X 2

Step 12

- With the hood open, insert Fire Bowl (23), Charcoal Grid (24), Cooking Grid Outer (25), Cooking Grid Inner (26) and Warming Rack (27) in the order as shown below.

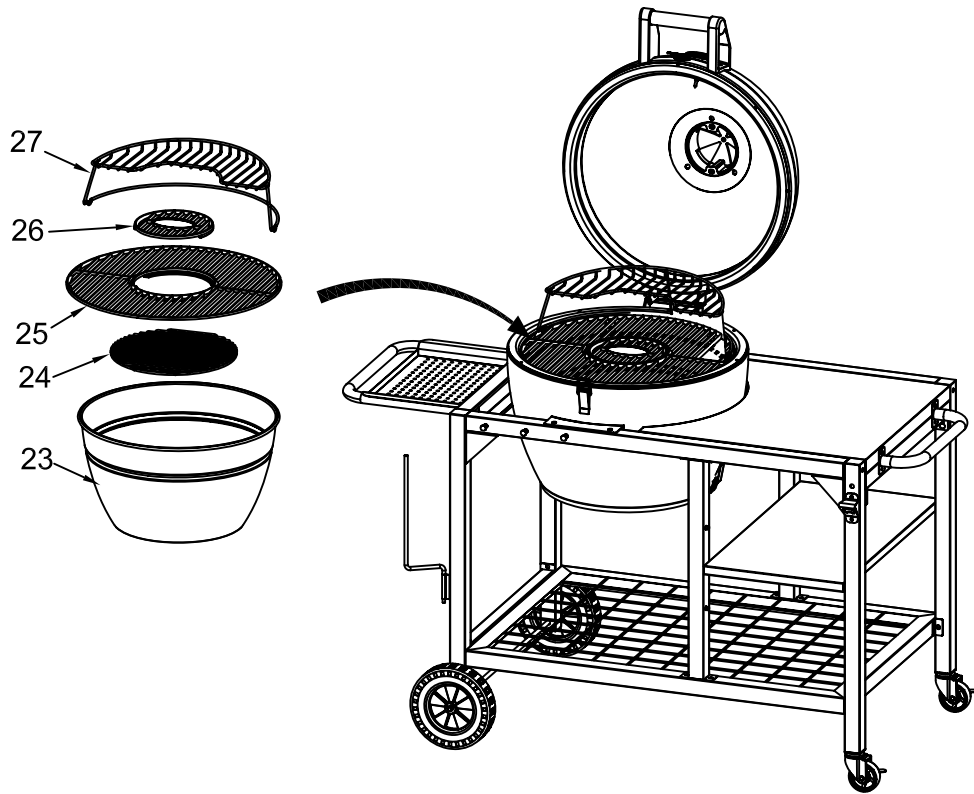

Step 13

- Insert Ash Pan Holder (21) into Ash Pan (22) and secure it with three Bolts (H) as shown below
- Attach on the Ash Pan prepared onto the bottom part of the firebox and secure it with the two locking clips as the sides as shown below.

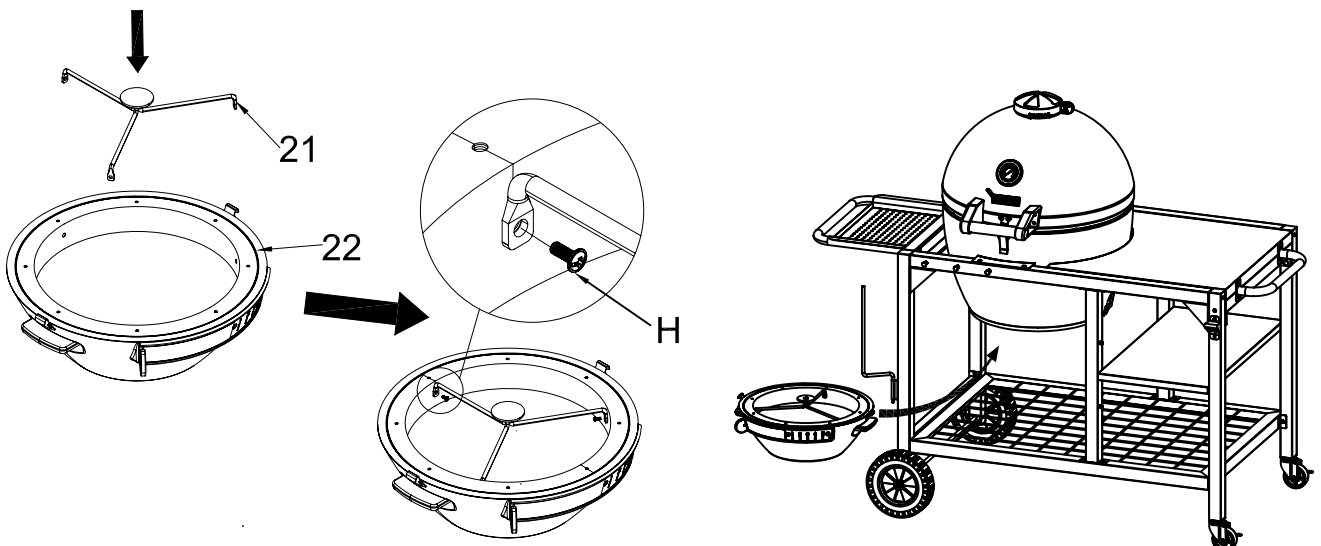

H → (M4*12) X 3

Operating Your Barbecue

CAUTION: Never use charcoal that has been pre-treated with lighter fluid.

First Use

1. Make sure all labels, packaging and protective films have been removed from the grill.
2. Remove manufacturing oils before cooking on the grill for the first time, by operation the grill for at least 15 minutes. This will "heat clean" the internal parts and dissipate odors.

Lighting Instructions

CAUTION: Set the BBQ up on a hard non-combustible level surface.

CAUTION: Keep the outdoor cooking appliance area clear and free from combustible materials, gasoline and other flammable vapors and liquids.

CAUTION: Check to make sure the air vents are free of debris and ash before using the grill.

CAUTION: DO NOT use lighting fluid, gas or other combustible liquids to ignite the charcoal. Liquid chemicals are fire and explosion hazard and they will cause an undesirable taste to food.

CAUTION: DO NOT use "Instant Light" briquettes. This will cause the same undesirable taste.

1. Remove the cooking grids.
2. Place about 1 to 2kgs of charcoal on the charcoal grid. Pile charcoal in a pyramid shape.
3. Open bottom vent fully and leave the hood open.
4. Ignite charcoal as instructed on charcoal packaging.
5. When the charcoal is fully lit, arrange coals with long handled tongs per "Direct Cooking" or "Indirect Cooking" section.
6. Fit the cooking grids in place.
7. Close the hood and adjust air flow until the desired temperature is reached.
8. Pre-heat for 10 to 15 minutes prior to cooking. Do not cook before the fuel has a coating of ash.

Note: A charcoal starter chimney is a helpful alternative for lighting.

Controlling the Temperature

1. With the Charcoal fully lit and hood closed, make sure the bottom vent is fully open.
2. Open the top damper vent fully and monitor the temperature until it reaches your desired temperature.
3. Close the top damper vent half way, wait 5 minutes and check the temperature.
4. Adjusting the top damper vent by either closing it more (lower temperature) or opening it more (higher temperature).
5. Monitor the temperature during cooking and if you notice that the temperature has moved outside your desired range, adjust the top damper vent in very small increments and wait 1 - 2 minutes.



OPERATING INSTRUCTIONS (CONTINUE)

Direct Cooking / Fast Cooking

It is usually easier to achieve the higher desired temperatures by keeping the lower vent fully open and only adjusting the top damper vent.

1. Remove the cooking grids.
2. Load and Light charcoal per "Lighting Instructions" section.
3. While wearing protective gloves, carefully spread hot coals evenly across charcoal grid with long handle tongs.
(Please refer to the picture 'Direct Cooking' for how to set the coals)
4. While wearing protective gloves, replace cooking grid and allow grill to preheat.
5. Make sure the bottom vent is fully open. Open the top damper vent and monitor the temperature until it reaches your desired temperature.
6. Close the top damper vent half way, wait 5 minutes and check the temperature.
7. Adjust the top damper vent by either closing it more (lower temperature) or opening it more (higher temperature).
8. Once the desired temperature is achieved, set your food in place on the cooking grill. You can grill extra food on the warming rack. Close the hood and start cooking.
9. Monitor the temperature during cooking and if you notice that the temperature has moved outside your desired range, adjust the top damper vent in very small increments, wait 1-2 minutes and re-adjust if necessary.
10. Use a meat probe thermometer to take the guesswork out of knowing when your food is done.



Direct Cooking



Indirect Cooking

OPERATING INSTRUCTIONS (CONTINUE)

Indirect Cooking / Slow Cooking

The best way to achieve the lower required temperatures is by almost closing the lower vent. Adjust the top damper vent to control the airflow.

1. Remove the cooking grids.
2. Load and light charcoal per "Lighting Instructions" section.
Note: Take care not to use too much charcoal.
3. While wearing protective gloves, carefully spread hot coals at the periphery or half of charcoal grid with long handle tongs and set a drip pan into place on the charcoal grid.
(Please refer to the picture 'Indirect Cooking' for how to set the coals)
4. While wearing protective gloves, replace cooking grid and allow grill to preheat.
5. Close the hood, set the lower vent to 1 or 2 marks away from fully closed.
6. Close the top damper vent half way, wait 5 minutes and check the temperature.
7. Adjust the top damper vent by either closing it more (lower temperature) or opening it more (higher temperature).
8. Once the desired temperature is achieved, set your food in place on the cooking grill. You can grill extra food on the warming rack. Close the hood and start cooking.
9. Monitor the temperature during cooking and if you notice that the temperature has moved outside your desired range, adjust the top damper vent in very small increments, wait 1-2 minutes and re-adjust if necessary.
10. Use a meat probe thermometer to take the guesswork out of knowing when your food is done.

Food Cooking Information

- **ALWAYS** wash your hands before or after handling uncooked meat and before eating.
- **NEVER** place cooked meat on the same plate that raw meat was on.
- **DO NOT** use the same utensils to handle cooked and uncooked foods.
- Before cooking ensure barbeque grill surfaces and tools are clean and free of old food residue.

After Use Instructions

- Make sure all coals are fully extinguished and the BBQ is cool.
- Remove ashes.
- Wash BBQ with a mild detergent and rinse with water.
- Wipe dry with cloth or paper towel.
- Clean cooking grids and warming rack with a wire brush.
- Store in dry area.

DANGER!

DO NOT use charcoal briquettes for indoor cooking or heating. **TOXIC** carbon monoxide fumes can accumulate and cause asphyxiation and death!

DANGER!

This BBQ is not intended to be installed in or on recreational vehicles and / or boats. Live hot embers can create a fire hazard.

CAUTION: BEFORE ANY CARE AND MAINTENANCE IS ATTEMPTED PLEASE ENSURE THAT THE BARBEQUE ARE NOT IN USE AND THAT ALL SURFACES HAVE BEEN GIVEN SUFFICIENT TIME TO COOL DOWN.

Please note the following when maintaining and caring for your barbeque:

- Cleaning your barbeque regularly will help to keep a pristine appearance.
- Throwing cold water over any hot surface of the barbeque is NOT recommended and is potentially dangerous.
- Avoid handling and touching hot parts of the barbeque.

CARE OF THE BARBEQUE BODY

- Regular care and maintenance of the barbeque body will significantly increase its life and long term appearance.
- Excess grease and fat can be removed using grease remover and warm water with a soft scraper (not metal edged).
- The barbeque body should be fully cleaned by using hot soapy water and a sponge to avoid corrosion starting on dirty surfaces.
- Leave a light film of oil such as cooking spray on the metal parts to assist in rust prevention.
- Regularly spray screws and fasteners with an appropriate lubricant or rust preventer.
- If external paint is scratched or chipped it must be immediately covered with paint or a rust preventer.
- Keep the barbeque covered when it not in use.

Warranty

Two-Year Limited Warranty

This warranty is non-transferable and does not cover failures due to misuse of improper installation or maintenance.

This warranty is for replacement of defective parts only. We are not responsible for incidental or consequential damages or labor costs.

This warranty does not cover corrosion or discoloration after the grill is used, or lack of maintenance, hostile environment, accidents, alterations, abuse or neglect.

This warranty does not cover damage caused by heat, abrasive and chemical cleaners, or any damage to other components used in the installation or operation of the grill. And paint is not warranted and may require touch-up.

This warranty is void if this grill is ever used for commercial or rental purposes.

All warranty coverage applies only if this grill is used in the United States.

Some states do not allow the limitation or exclusion of incidental or consequential damages, so the above limitations or exclusions may not apply to you. This Warranty gives you specific legal rights, and you may also have other rights that vary from state to state.

Customer Service

Please do not return the grill to store.

If you have any questions or if you need replacement parts, please contact our customer service:

1-855-200-8445 ext 102 or
service@brandmangrill.com

We are pleased to help you with any question concerning replacement parts or your warranty.

Proof of purchase in the form of an original receipt with date of purchase is required.

DO NOT ship parts or units without a return authorization number. Upon receipt of an authorization number, the product must be shipped prepaid.

Captivate Brands USA, Inc.
25541 Arctic Ocean Drive,
Lake Forest, CA.92630

If you have any questions or problems,
you can contact our customer service at
1-855-200-8445 ext 102 or
service@brandmangrill.com
from 9:00 AM - 5:00 PM Monday to Friday.
(Pacific). All emails and voice-mail calls
will be answered within 24 hours.