



ASSEMBLY INSTRUCTIONS
INSTRUCTIONS D'ASSEMBLAGE
INSTRUCTIVO DE ARMADO

5 YEARS
ANS
AÑOS
WARRANTY
GARANTIE
GARANTÍA

Article/ Item/ Artículo

-769- Bibliothèque 3 tablettes avec portes
3-Shelf Bookcase with Doors
Estantería

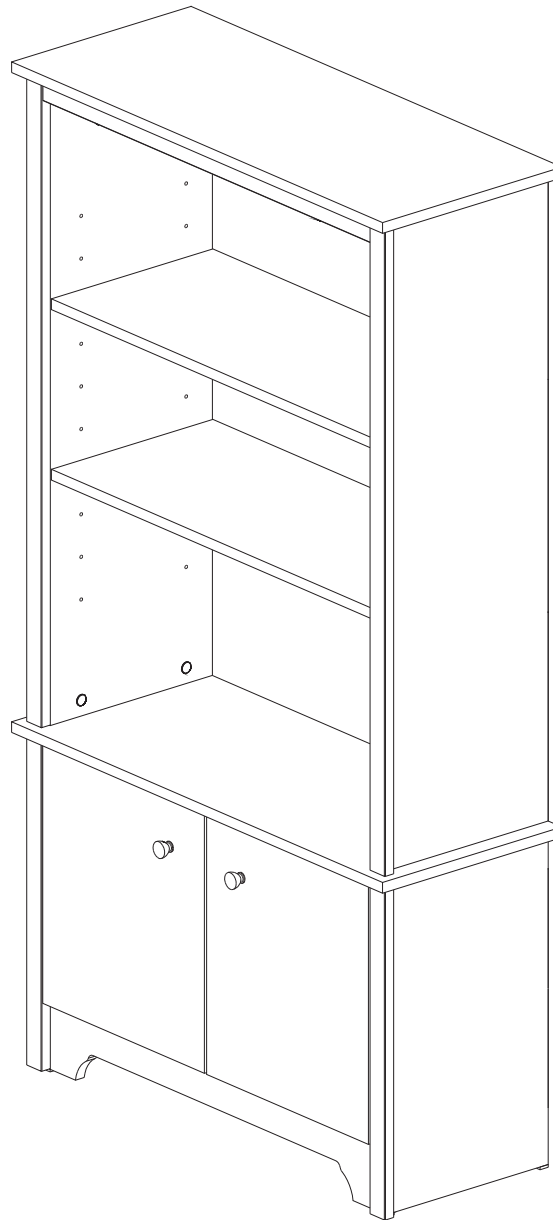
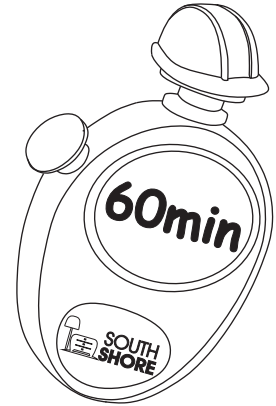

 1-800-290-0465 



ADULT ASSEMBLY REQUIRED
DOIT ÊTRE ASSEMBLÉ PAR UN ADULTE
DEBE DE SER ARMADO POR UN ADULTO

#Instructions/ #Instructions/ #Instructivo

#10024681

WARNING

Serious or fatal crushing injuries can occur from furniture tip-over. To help prevent tip-over:

- Place heaviest items in the lowest drawers.
- Do not set TVs or other heavy objects on the top of this product. Never allow children to climb or hang on drawers, doors, or shelves.
- Never open more than one drawer at a time.

Use of tip-over restraints only reduce, but not eliminate, the risk of tip-over.

AVERTISSEMENT

Des blessures graves ou fatales peuvent résulter du basculement du meuble.

Afin d'éviter le basculement :

- Placer les items les plus lourds dans les tiroirs du bas.
- Ne pas placer de TV ou d'autres objets lourds sur ce produit. Ne jamais laisser un enfant grimper sur les tiroirs, les portes et les tablettes ou s'accrocher à ceux-ci.
- Ne jamais ouvrir plus d'un tiroir à la fois.

L'utilisation de dispositif anti-basculement ne peut que réduire les risques de basculement, sans les éliminer totalement.

ADVERTENCIA

El volcadura del mueble puede ser causa de lesiones graves o de un Atropellamiento fatal.

Para evitar la volcadura:

- Ponga las cosas pesadas en los cajones más bajos.
- No ponga televisores u otros objetos pesados encima de este producto. Nunca permita que un niño se Suba o se cuelgue en cajones, puertas o estantes.
- Nunca abra más de un cajón a la vez.

El uso de sujetadores para evitar La volcadura sólo puede disminuir El riesgo de una volcadura, Pero no lo elimina.

-769-

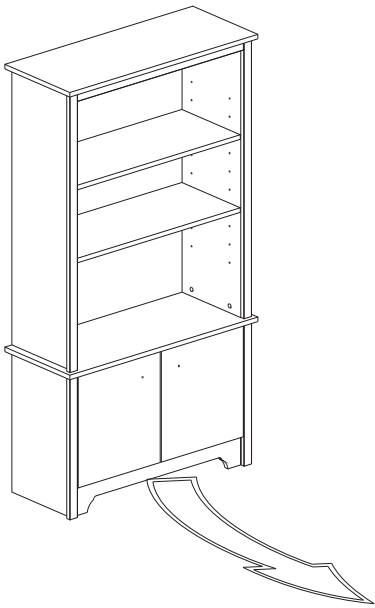

LEFT SIDE
CÔTÉ GAUCHE
LADO IZQUIERDO

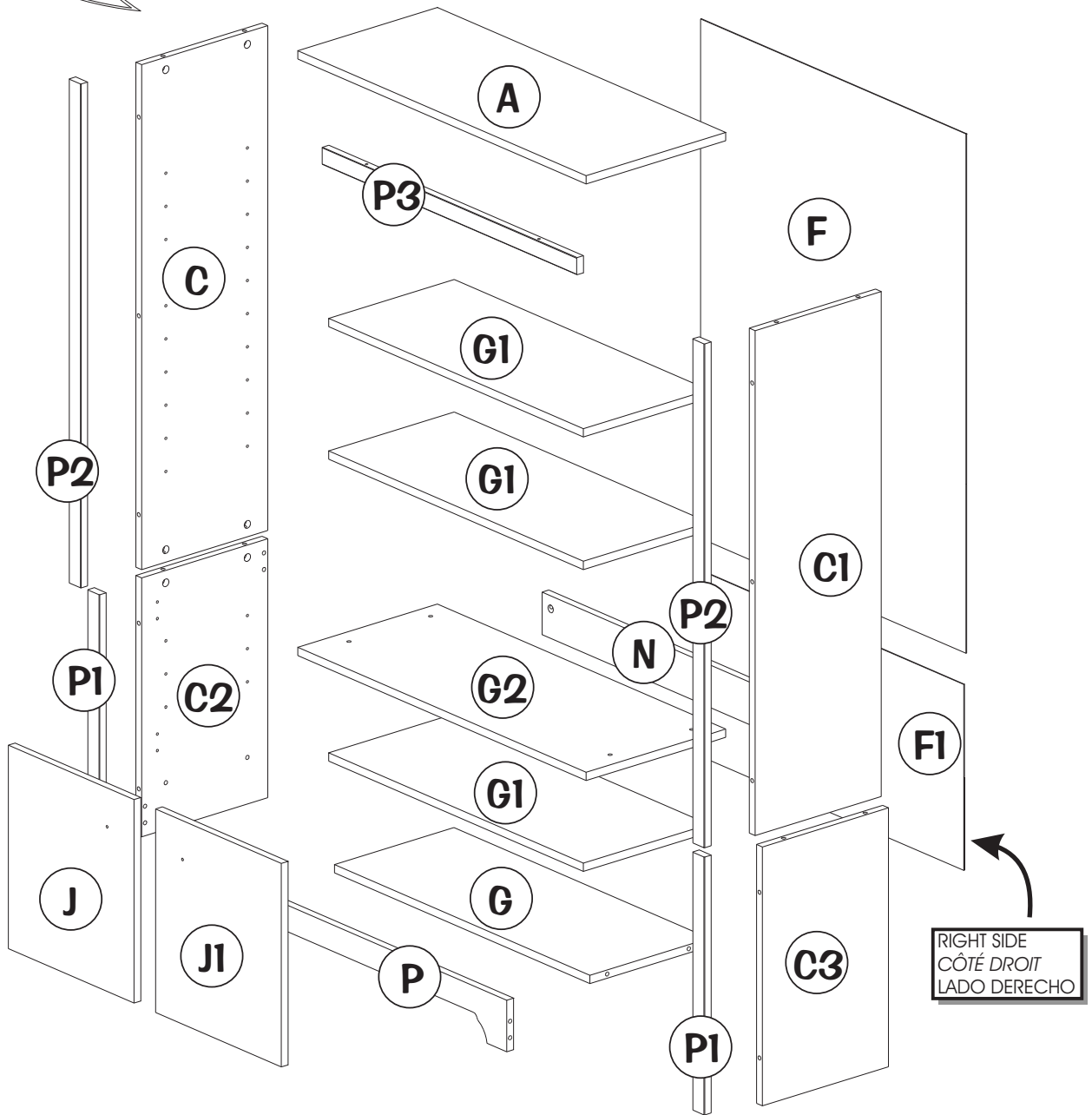

RIGHT SIDE
CÔTÉ DROIT
LADO DERECHO

N.B.: It is important to carefully read all instructions before beginning the assembly and before use of the furniture. Keep the assembly instructions for future use and for warranty purposes.

N.B. Il est important de bien lire toutes les instructions avant de commencer l'assemblage et avant d'utiliser le meuble. Gardez les instructions d'assemblage pour utilisation future et pour la garantie,

N.B. Lea con detenimiento las instrucciones antes de comenzar a ensamblar y antes de utilizar su mueble. Guarde el instructivo de ensamble para un futuro uso y para usos de garantía.

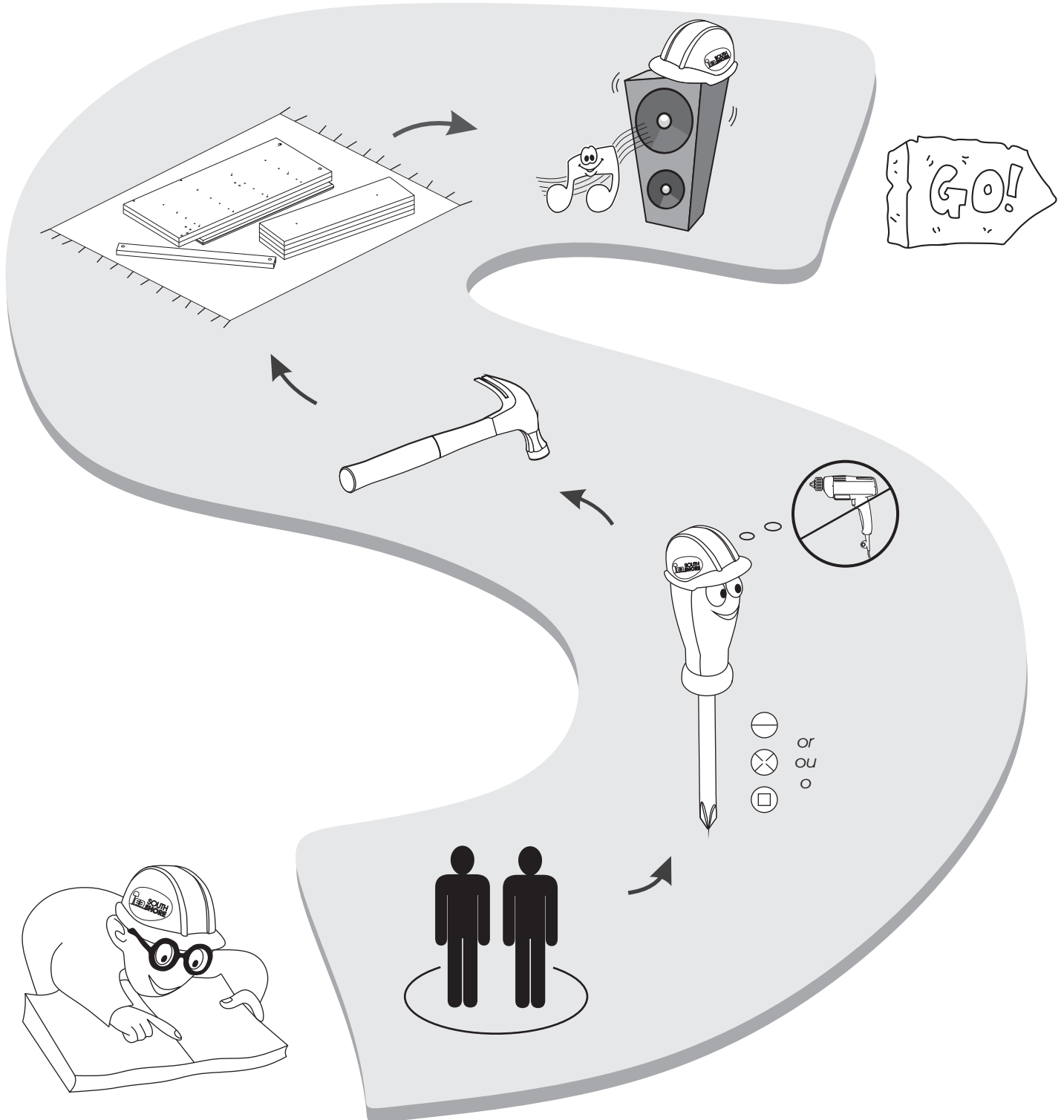

THINGS TO REMEMBER FOR ASSEMBLING/À RETENIR LORS DE L'ASSEMBLAGE/ A RECORDAR DURANTE EL ENSAMBLAJE

THINGS TO REMEMBER FOR ASSEMBLING/À RETENIR LORS DE L'ASSEMBLAGE/ A RECORDAR DURANTE EL ENSAMBLAJE

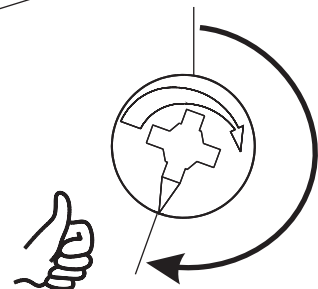
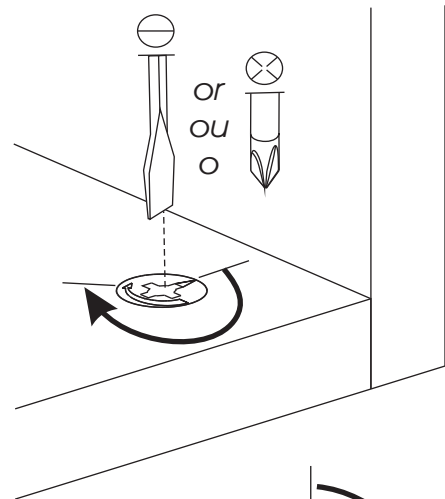
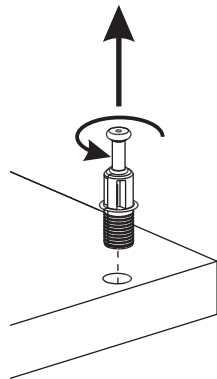
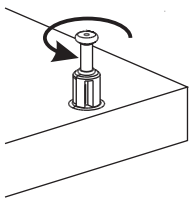
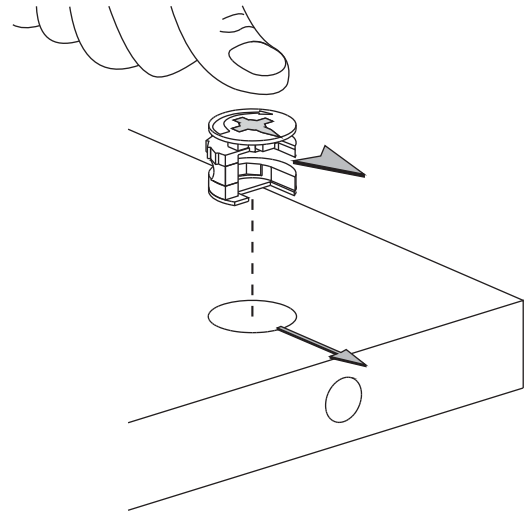
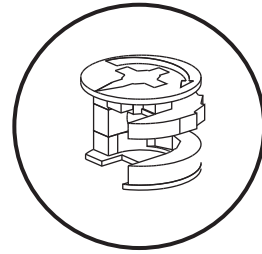
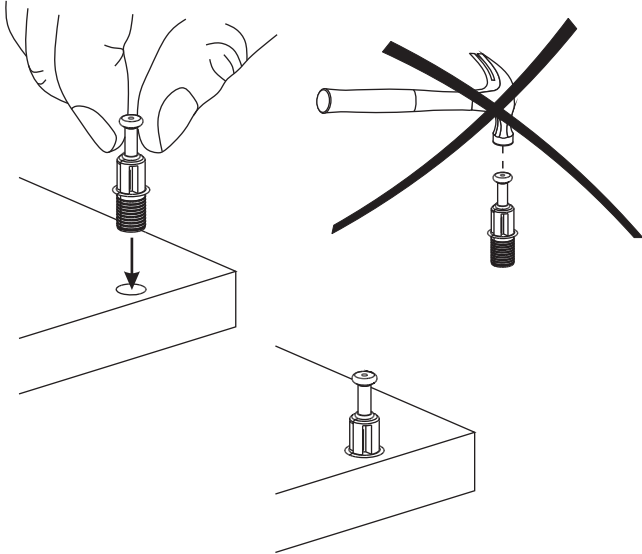
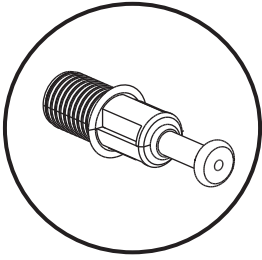

HARDWARE (full scale)

QUINCAILLERIE (taille réelle)

HERRAJE (de tamaño real)



90 (x40)

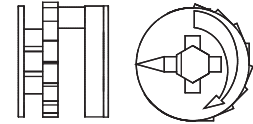

158 (x18)

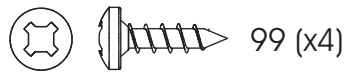

99 (x4)

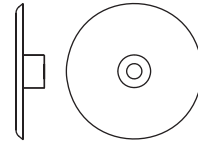

171 (x8)

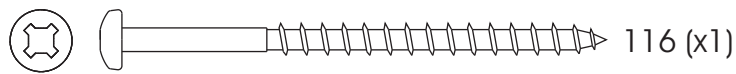

116 (x1)

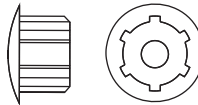

172 (x2)



121 (x2)

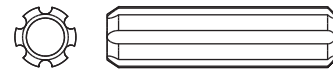

231 (x6)

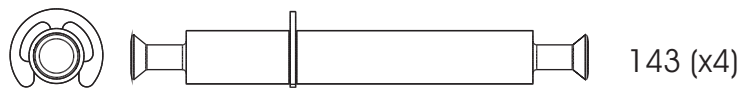

143 (x4)

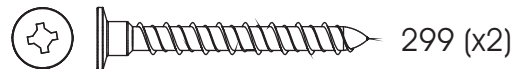

299 (x2)



144 (x10)

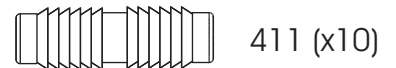

411 (x10)

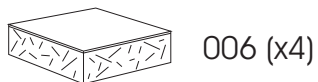

006 (x4)

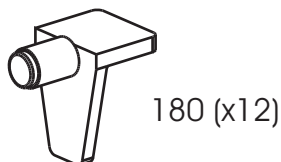

180 (x12)

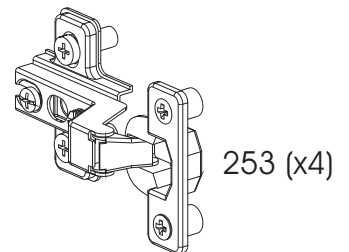

253 (x4)



035 (x2)

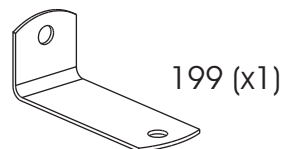

199 (x1)

* Hardware package may have spare parts .

* Le sac de quincaillerie peut contenir des pièces de remplacement .

* La bolsa de herraje puede contener piezas adicionales de repuesto .

1

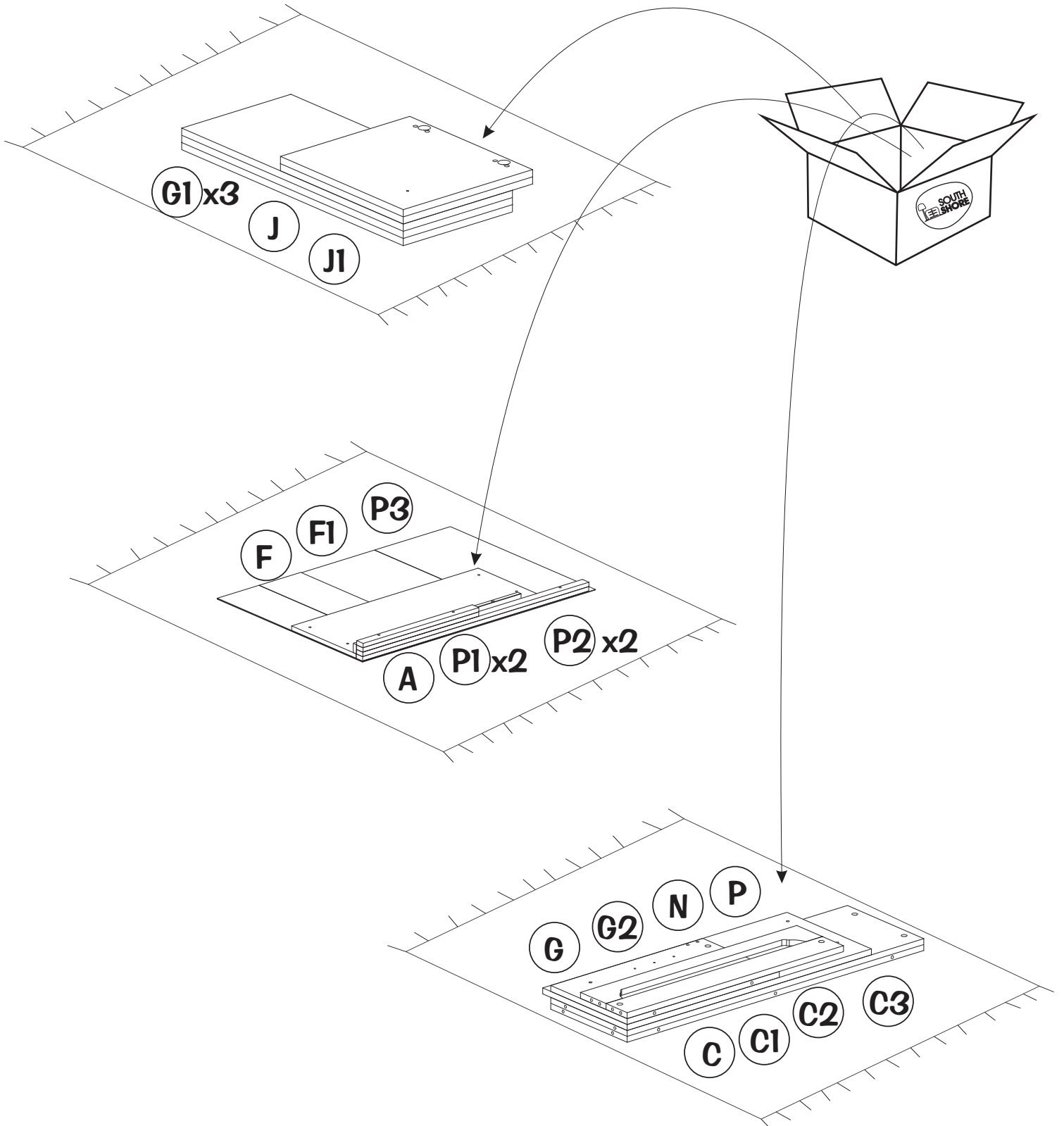
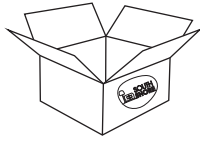

2

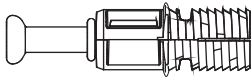

144 (x3)

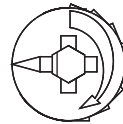
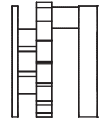

158 (x6)

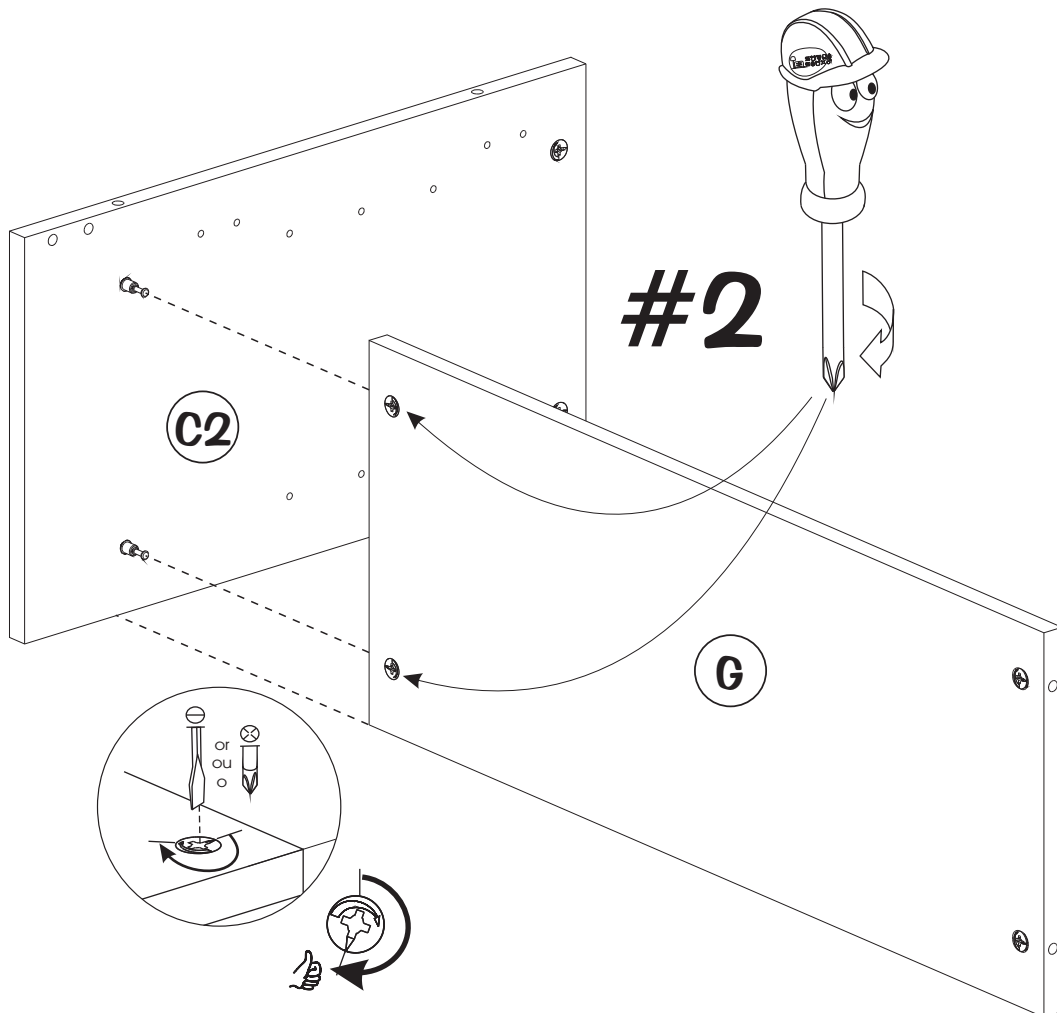
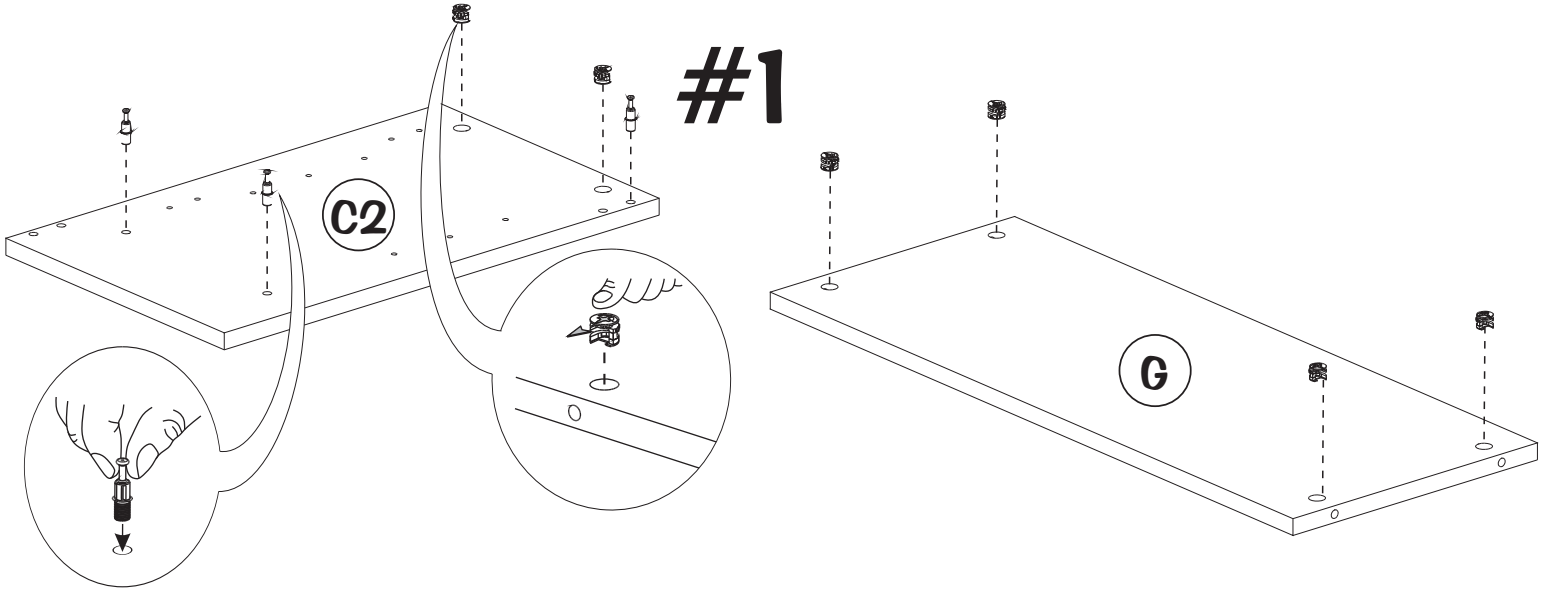

3

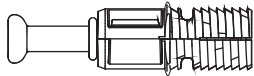

144 (x3)

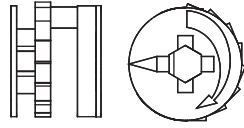

158 (x4)

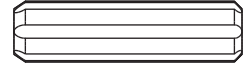

231 (x6)

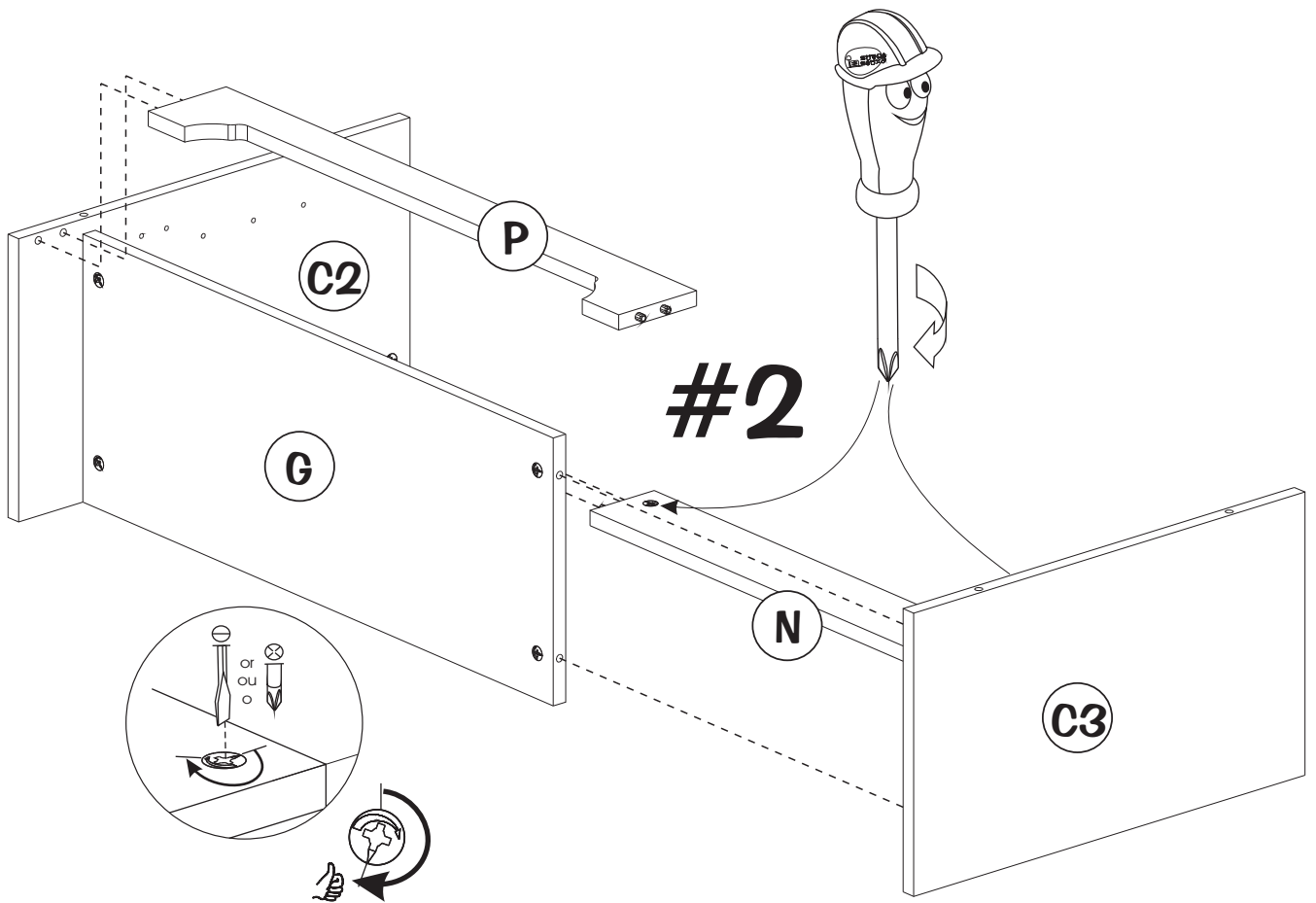
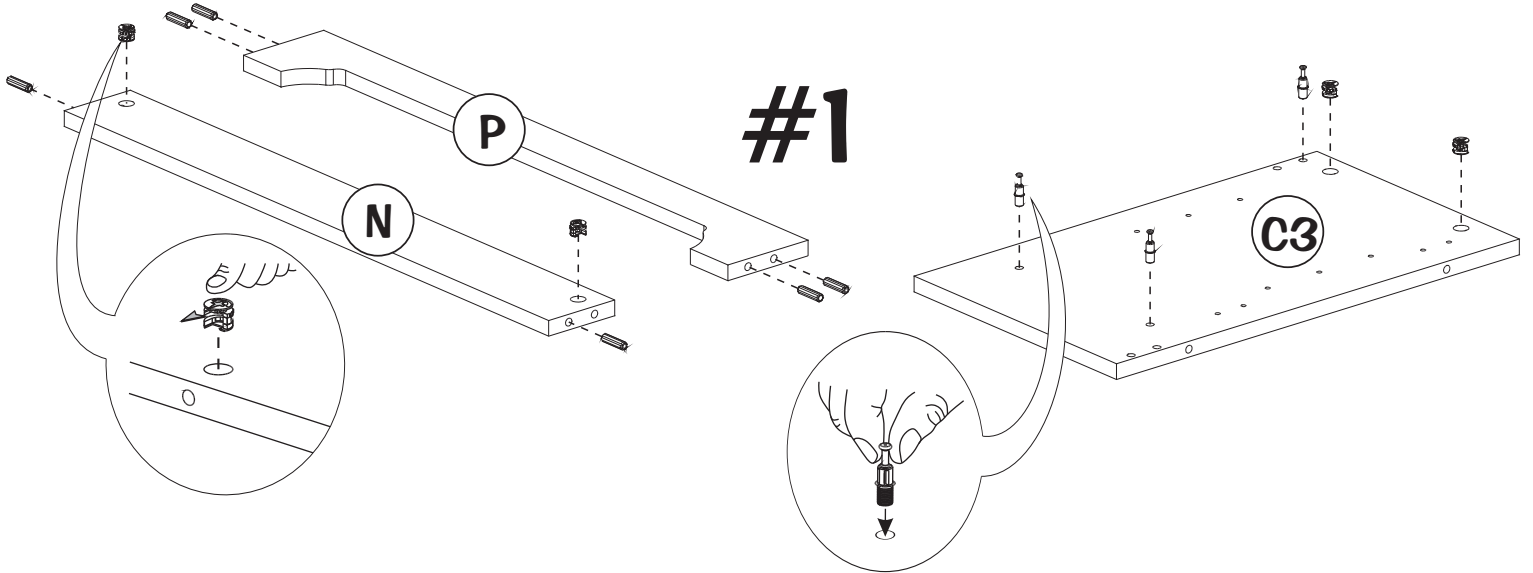

4

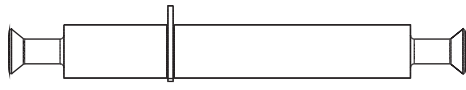

143 (x4)

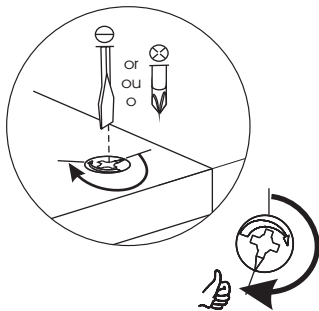
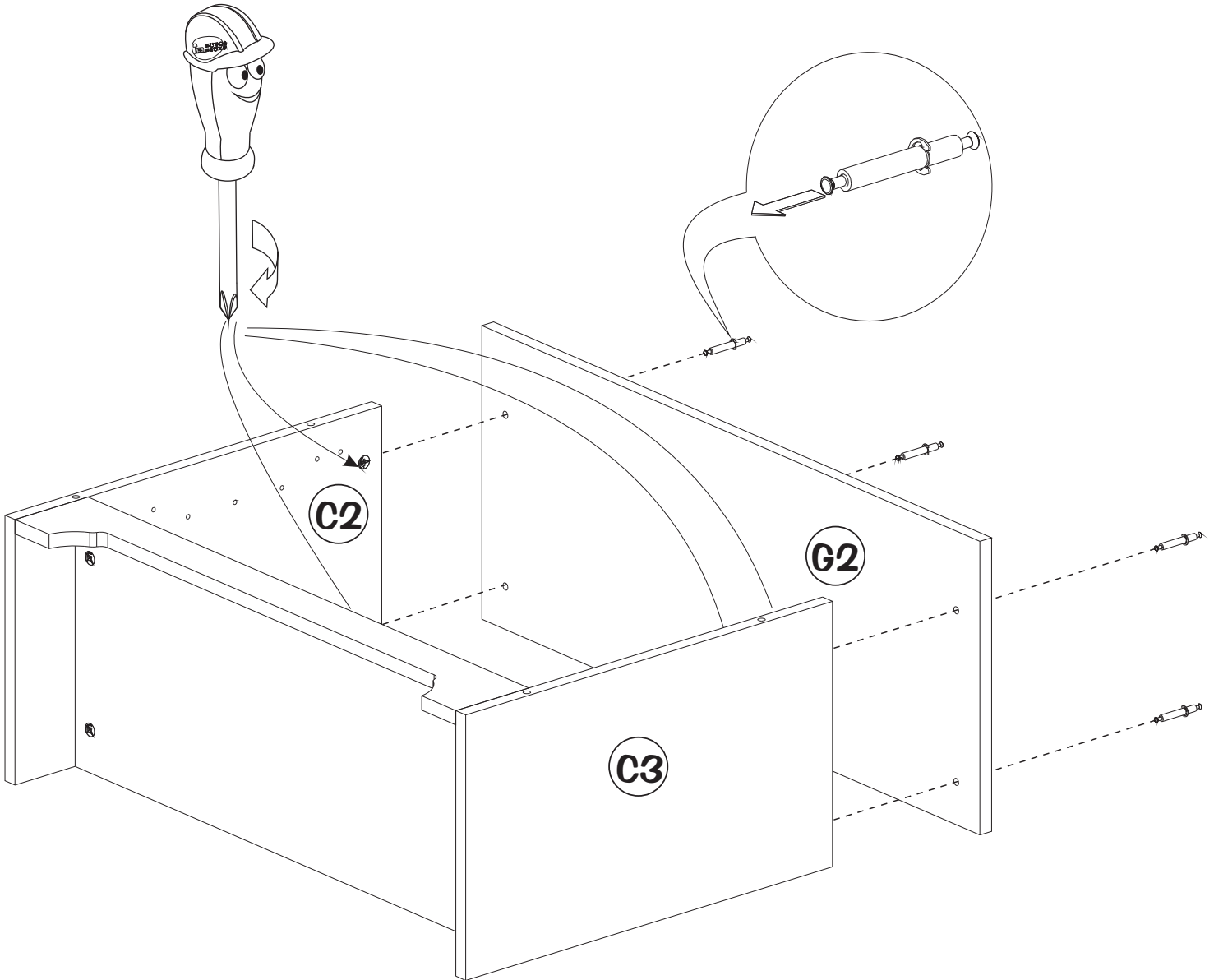

5

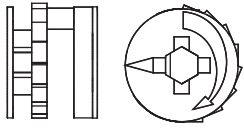

158 (x8)

#1

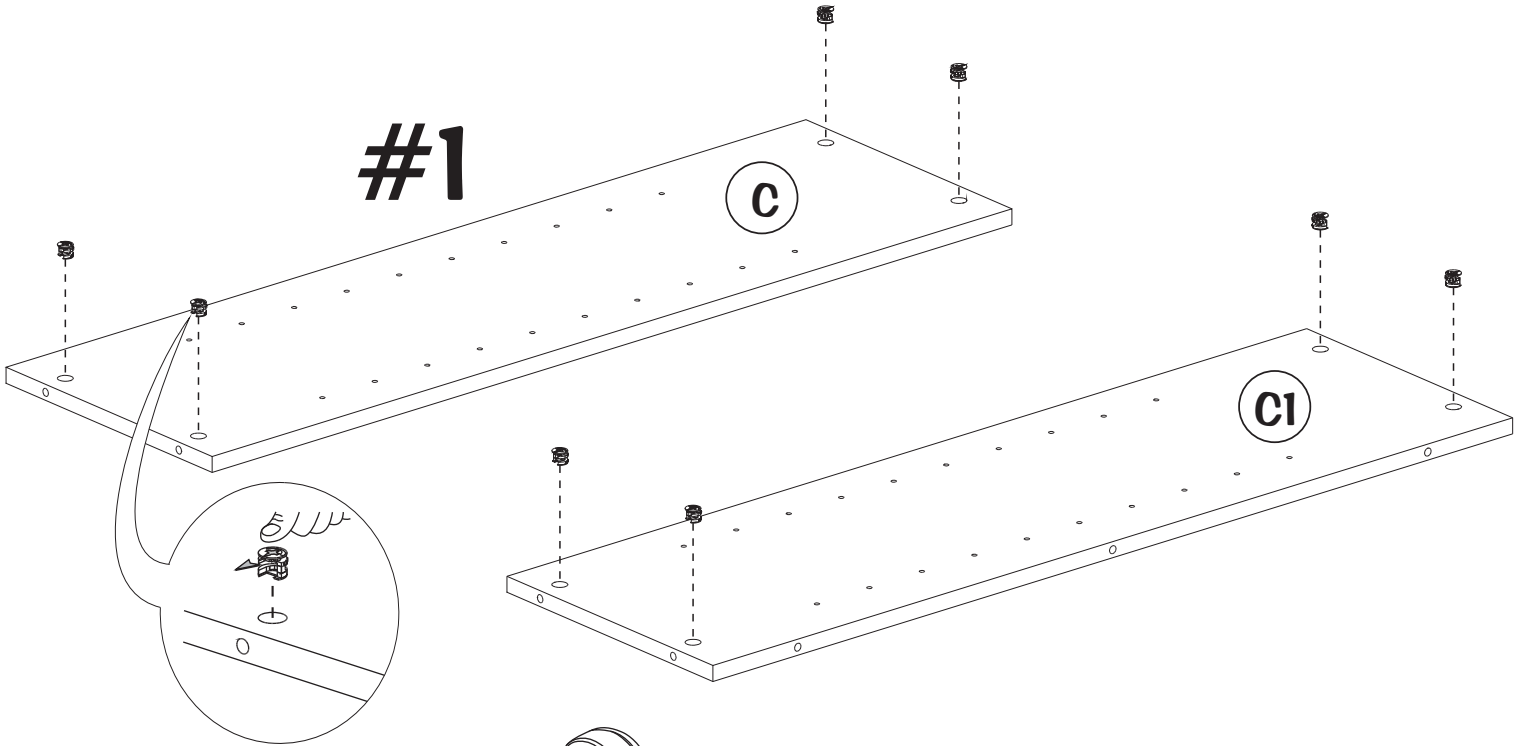

#2

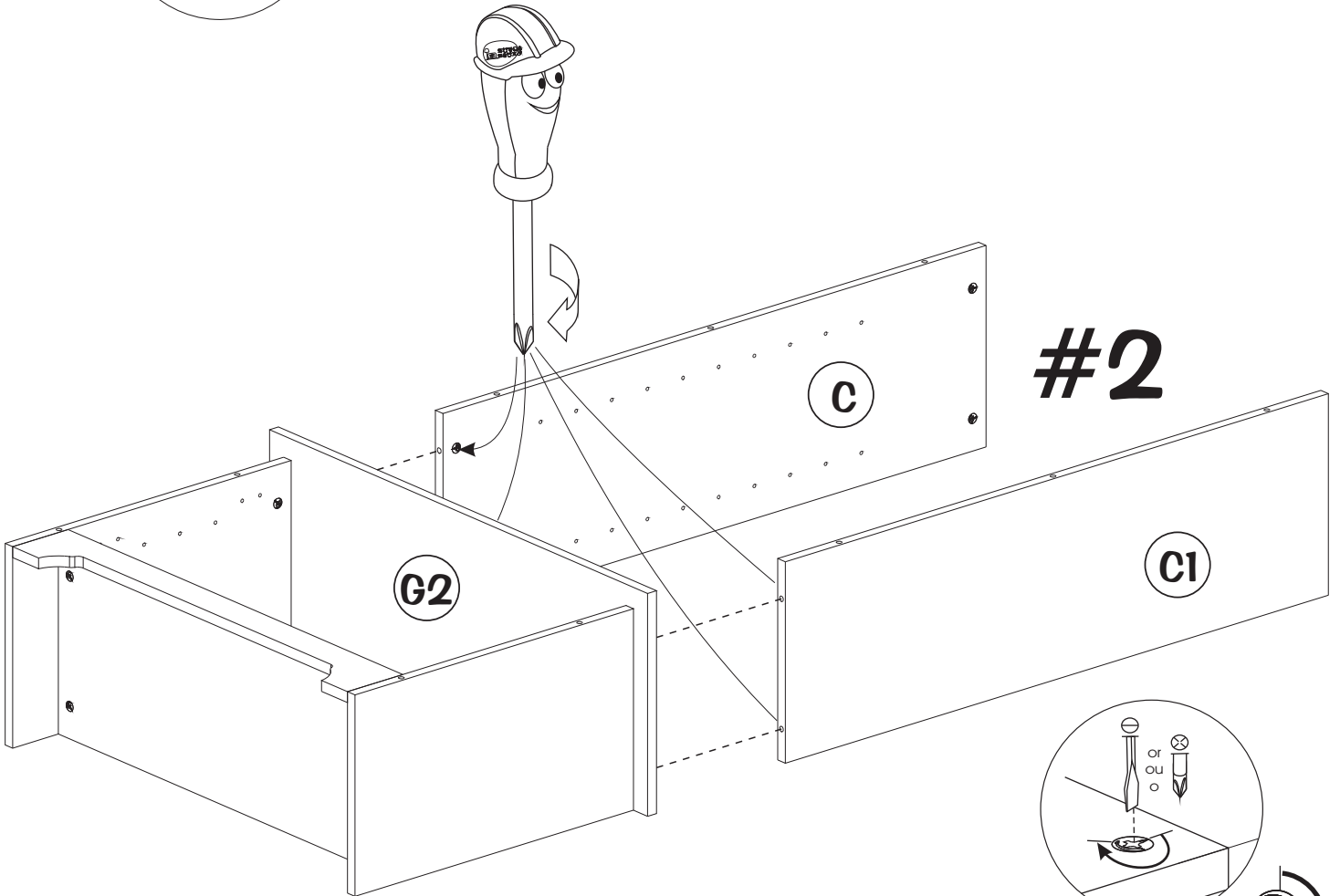

6

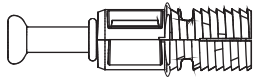

144 (x4)



299 (x2)

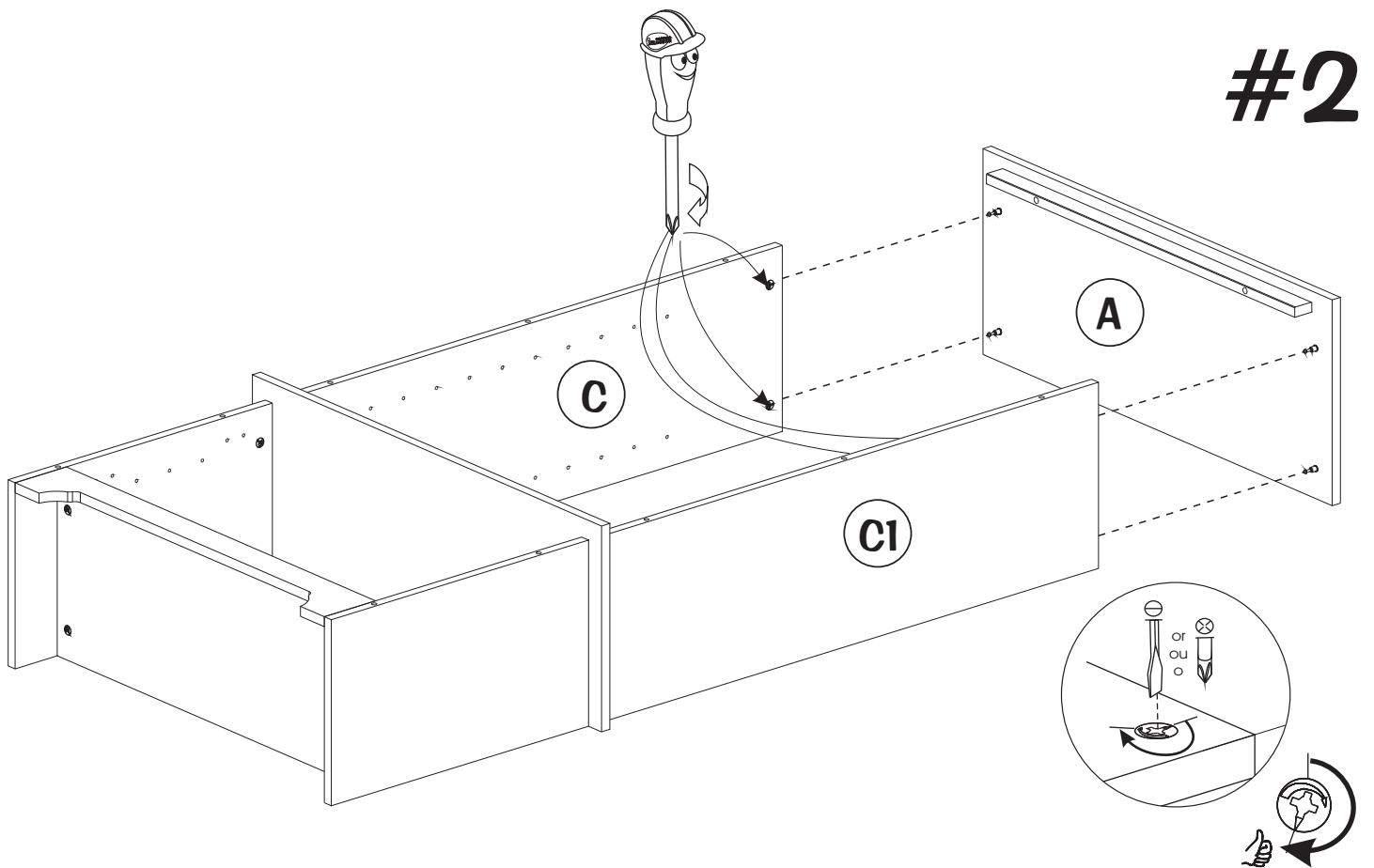
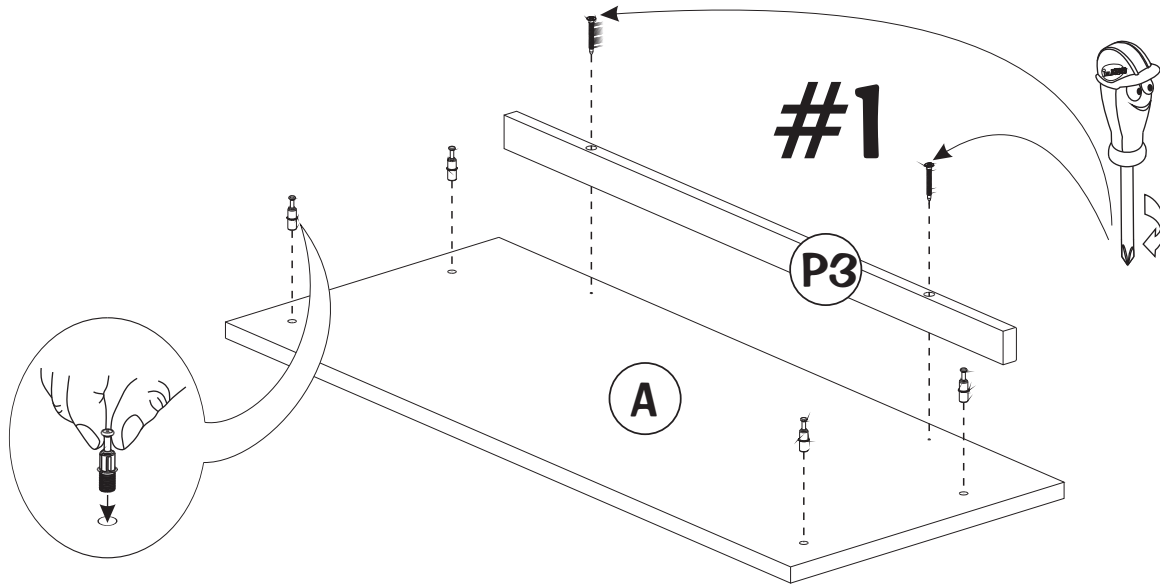

7

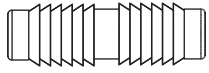

411 (x10)

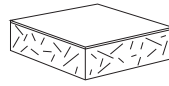

006 (x4)

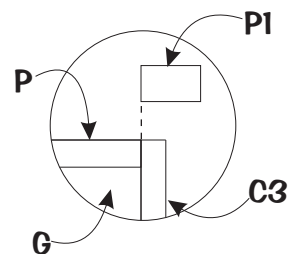
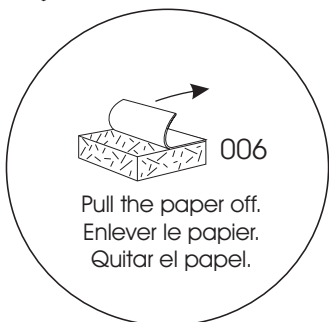
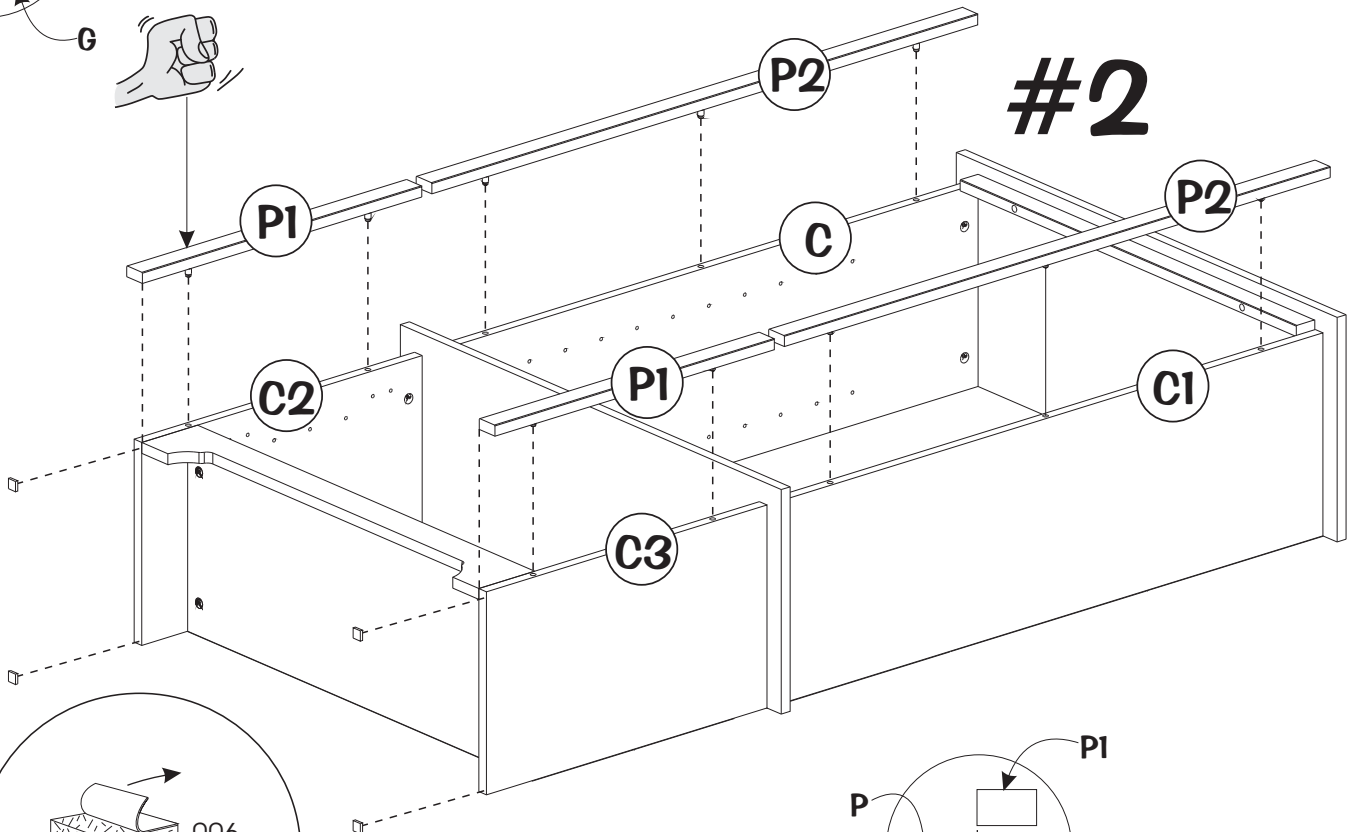
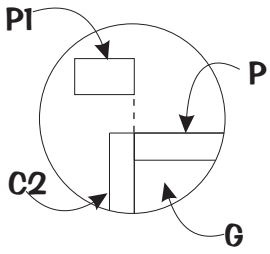
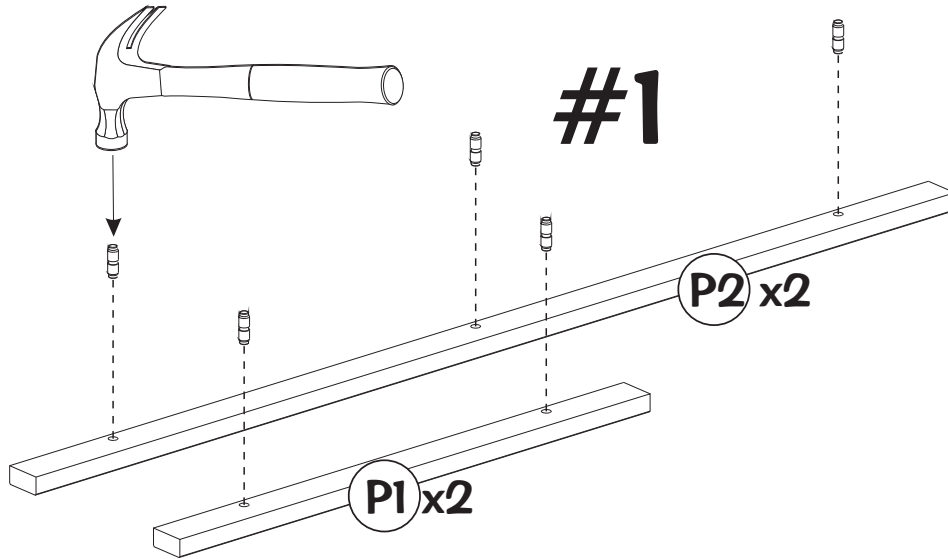

8

 90 (x40)

 99 (x3)

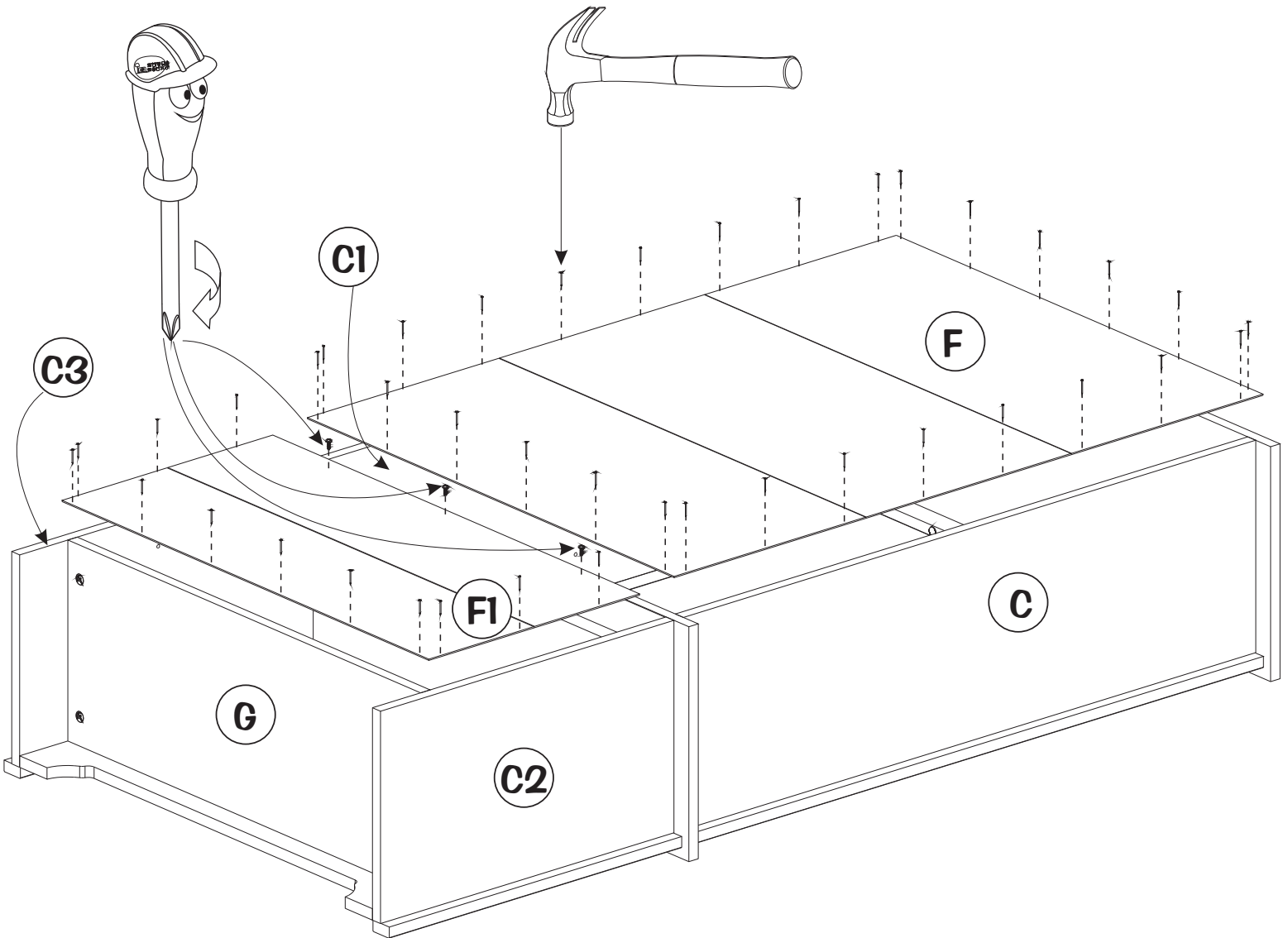
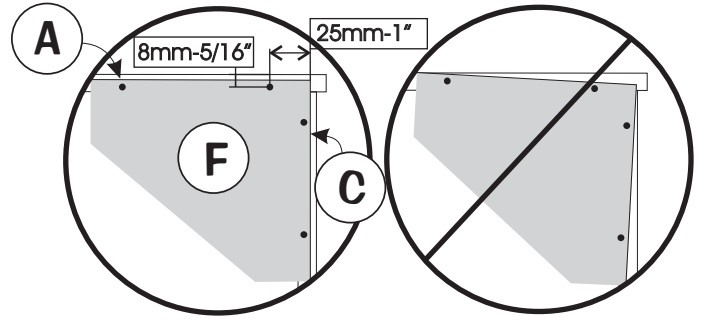

9

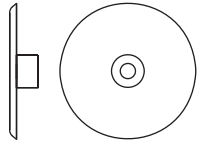

171 (x8)

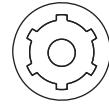

172 (x2)

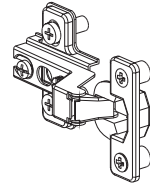

253 (x4)

P3

#1

C

C1

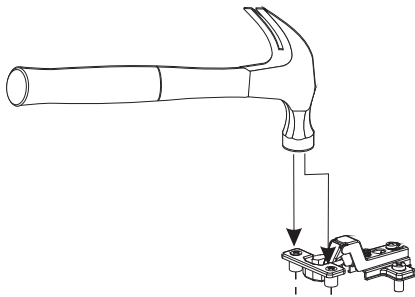

#2

J

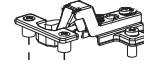
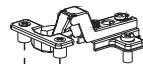

J1

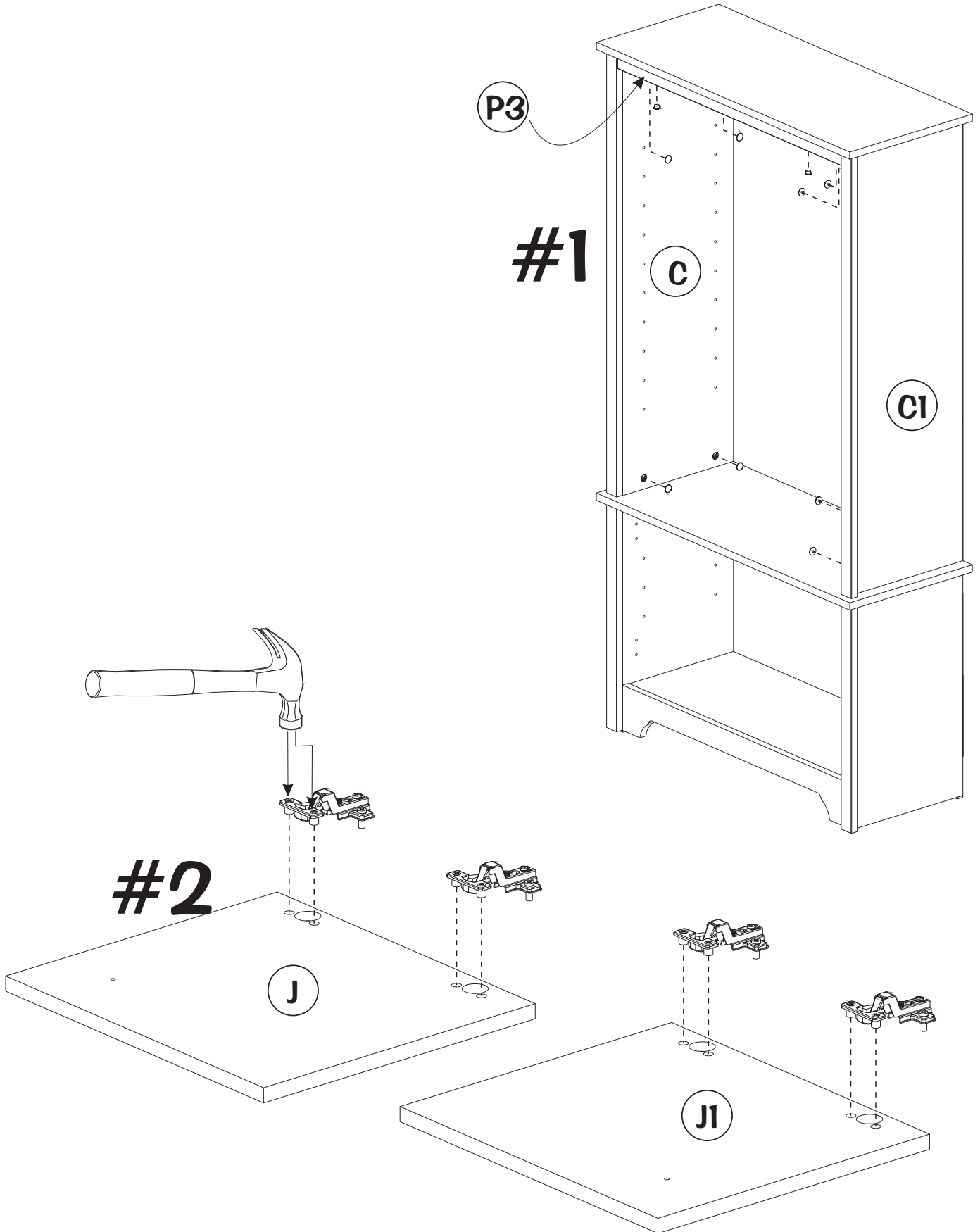

10

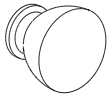

035 (x2)

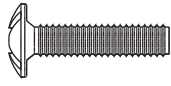

121 (x2)

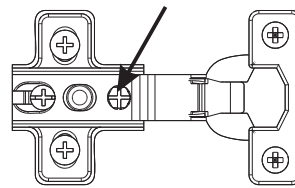
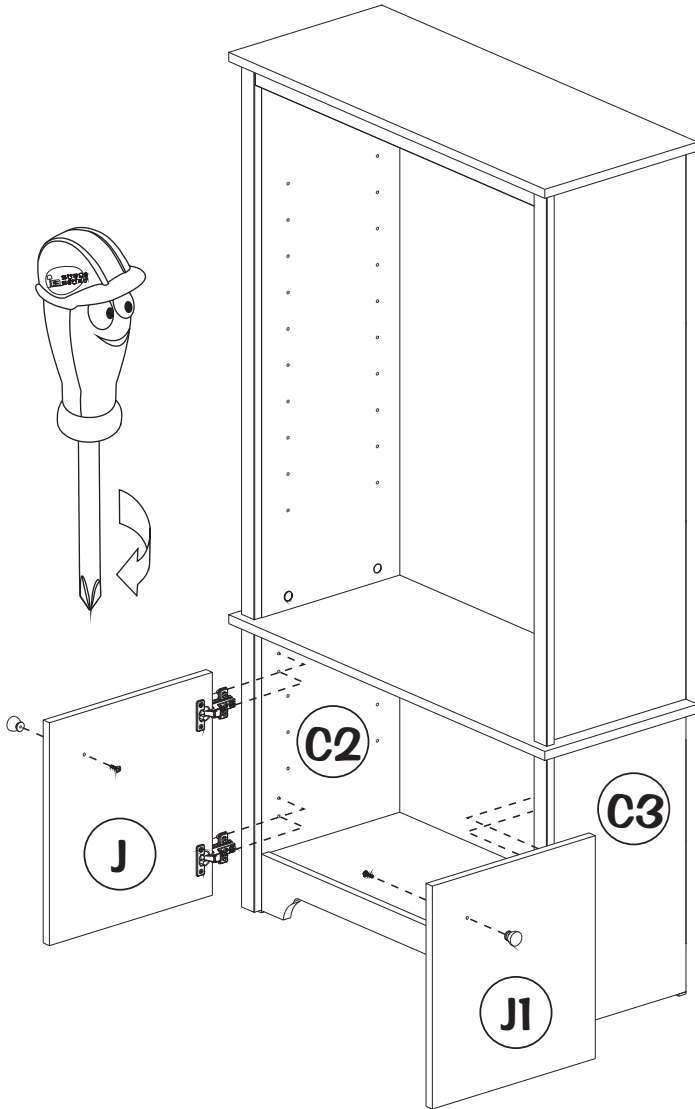

-LEFT/ RIGHT
-GAUCHE/ DROITE
-IZQUIERDA/ DERECHA

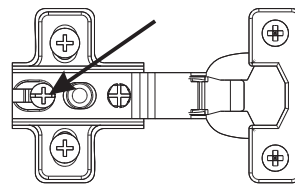
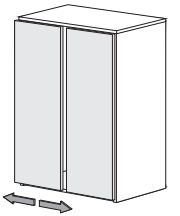

-DEPTH
-PROFONDEUR
-PROFUNDIDAD

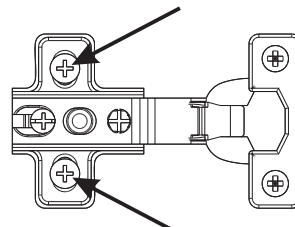
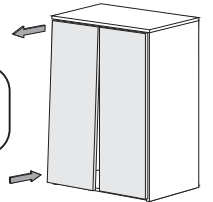

-HEIGHT
-HAUTEUR
-ALTURA

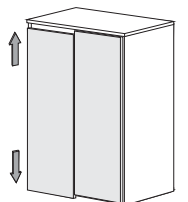

* Doors adjustment (Hinges)

* *Ajustement des portes (Charnières)*

* Ajuste de las puertas (Bisagras)

* Make sure the unit is level.

Loosen the concerned screw(s), adjust, and tighten.

* *Assurez-vous que le meuble soit au niveau.*

Déserrer la(les) vis concernée(s), ajuster, et resserrer.

* Cerciorarse de que la unidad se encuentre a nivel.

Desapretar los atornillos apropiados, ajustar, y apretar.

11

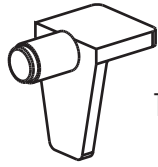

180 (x12)

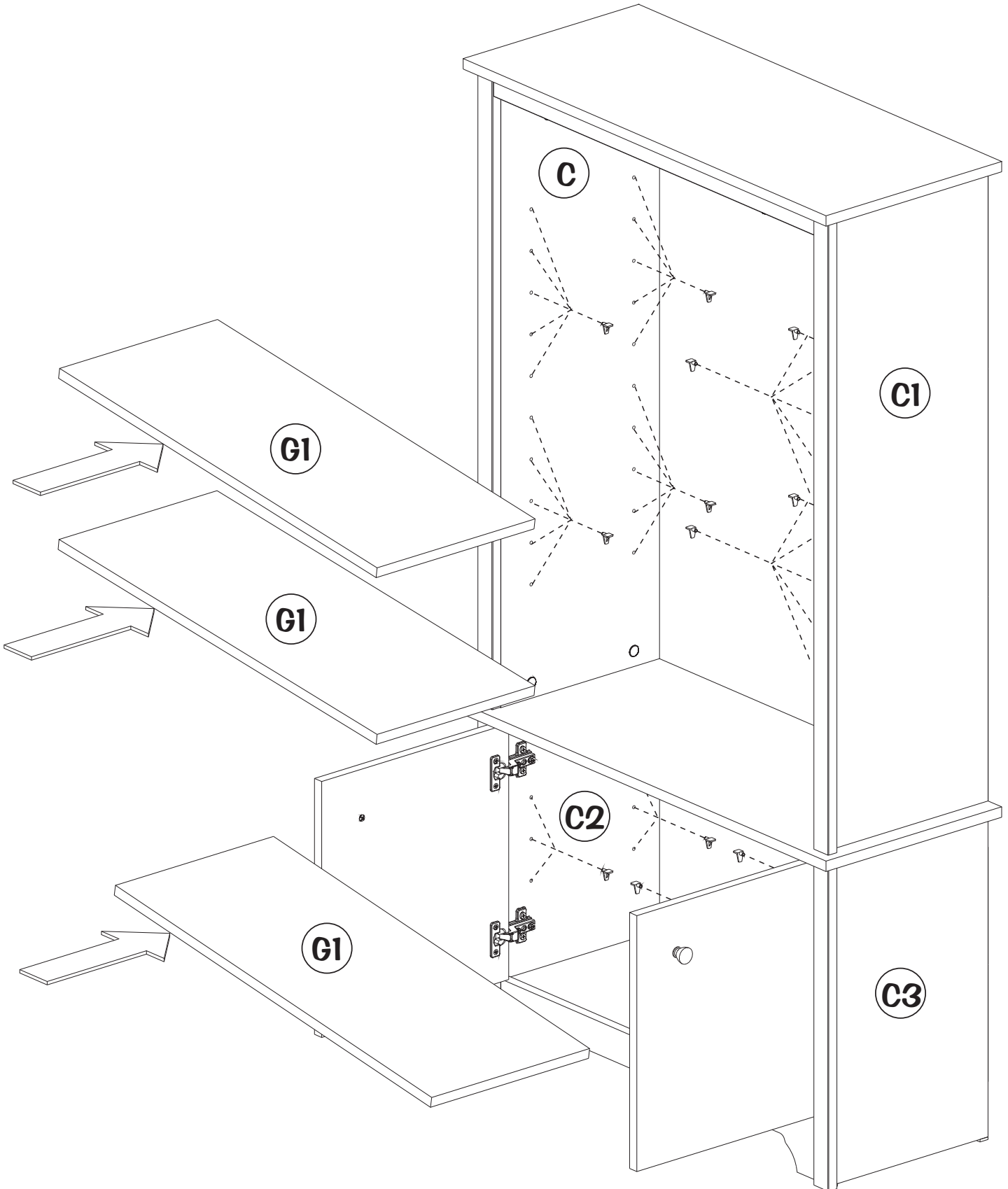

-Safety bracket installation
-Installation de l'équerre de sécurité
-Instalación del escuadra de seguridad

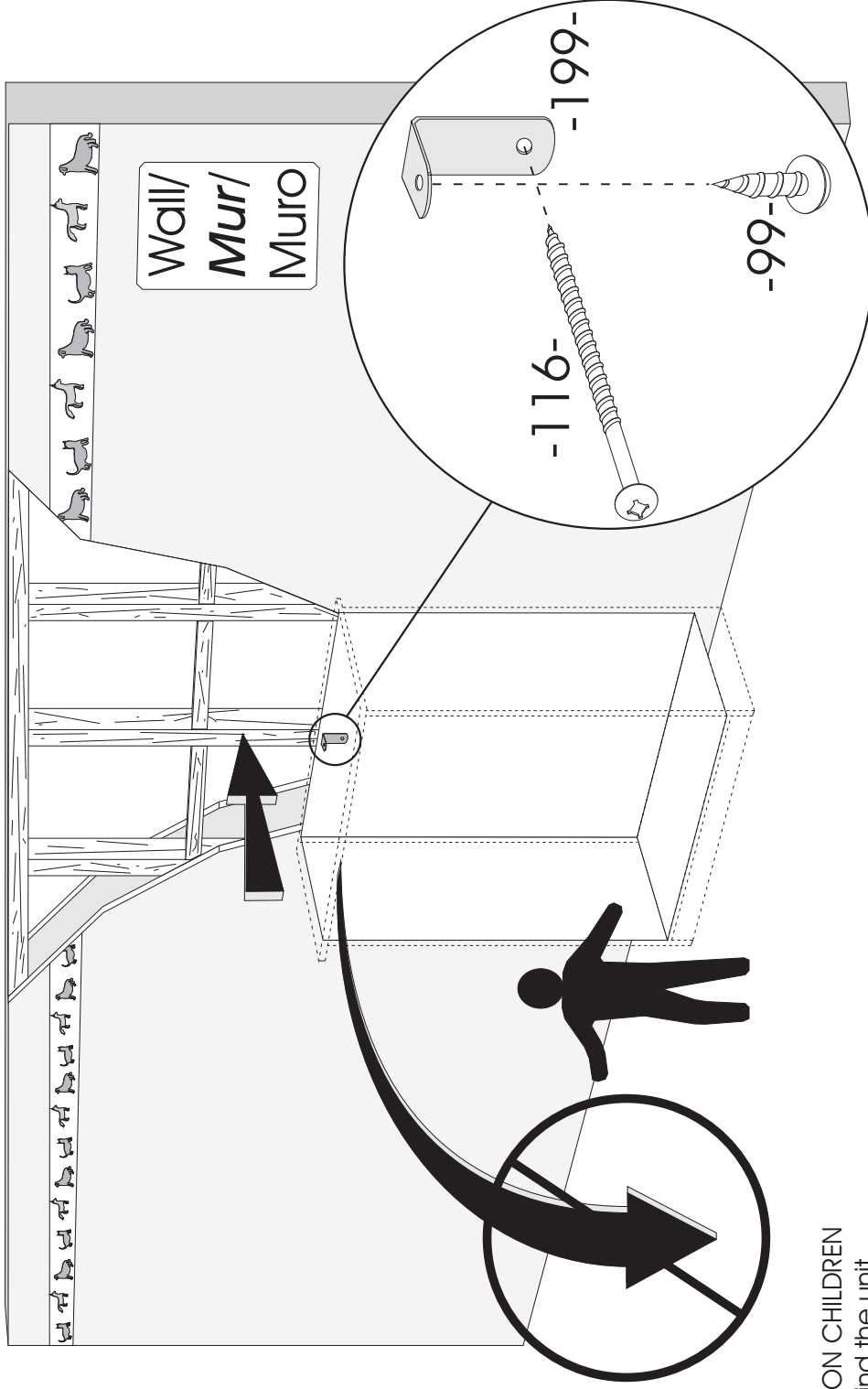

• TO PREVENT THE UNIT FALLING ON CHILDREN

Locate a stud in the wall behind the unit.

Screw -199- under the top with -99-. And through the back of the unit with -116- into the solid part of the wall.

• If the safety bracket is not in the box, please contact the consumers service in order to obtain another one before using the furniture.

• POUR EMPÊCHER LE MEUBLE DE BASCULER SUR LES ENFANTS

Localiser un colombage, dans la largeur du meuble.

Visser -199- sous le dessus du meuble avec -99-. Et à travers le dos du meuble avec -116-, dans la partie solide du mur.

• Si le crochet est absent, veuillez contacter notre service aux consommateurs pour obtenir cette pièce avant l'utilisation

• POR IMPEDIR QUE EL MUEBLE VOLQUE SOBRE LOS NIÑOS.

Localizar una viga, en la anchura del mueble.

Atornillar -199- debajo la pieza del encima con -99-. Y a través del dorso del mueble con -116-, en la parte sólida del muro.

• Si falta el gancho de seguridad, deba ponerse en contacto con nuestro servicio al cliente para obtener un gancho antes de utilizar el mueble.

MAINTENANCE TIPS / CONSEILS D'ENTRETIEN / CONSEJOS DE MANTENIMIENTO

- Never let liquids or damp cloths sit on this furniture.
- *Ne jamais laisser de liquide ou linge humide sur le meuble.*
- Nunca deje un líquido o un trapo húmedo sobre el mueble.



- Never use chemical cleaning products. They can damage the finish. For cleaning, use only a slightly damp cloth and wipe dry.
- *Ne jamais utiliser de nettoyeurs à base de produits chimiques, cela va endommager le fini. Utiliser seulement un linge légèrement humide.*
- Nunca utilice limpiadores a base de químicos, estos dañaran le acabado. Use sólo un paño húmedo.



- To avoid dulling of the finish, do not place furniture in direct sunlight.
- *Ne pas placer le meuble directement au soleil pour prévenir le ternissement.*
- No exponga el mueble directamente al sol para prevenir empañamiento.

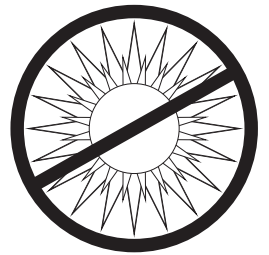

- Do not put plastic or rubber rings under appliances. Use cloth or felt protectors.
- *Évitez de déposer des appareils avec des rondelles de plastique ou de caoutchouc. Utilisez un protecteur en tissu ou en feutre.*
- Evite apoyar aparatos con redondeles de plástico o de goma. Utilizar un protector de tela o de fieltro.



- To clean, use a soft or slightly damp cloth, then wipe with a clean, dry cloth.
- *Pour nettoyer, utilisez un linge doux ou légèrement humecté. Essuyez par la suite avec un linge propre et sec.*
- Para limpiar, utilice un trapo suave o ligeramente humedecido. Seque luego con un trapo limpio y seco.



5 YEAR LIMITED WARRANTY

1. South Shore™ Furniture provides the original buyer with a warranty covering "defects" on furniture parts and workmanship for a period of 5 years from the date of purchase.
2. The word "defect" as used in this warranty is defined as any imperfection that may impair the intended use of the product.
3. This warranty is strictly limited to the repair or replacement of defective component parts, and excludes all other direct or indirect charges and expenses up to the limit permitted by law in your state/province.
4. In the case of a discontinued part or product, South Shore™ Furniture promises to reimburse the value of that part or product.
5. If a replacement part is unavailable, South Shore™ Furniture's liability to the buyer will not exceed the production cost of the part in question.
6. This warranty only applies under conditions of normal domestic use. It does not cover defects resulting from commercial use, intentional damage, negligence, abuse, product modification, accidents, exposure to the elements, or maintenance that does not comply with the guidelines on our website.
7. To honor this warranty, South Shore™ Furniture reserves the right to verify the grounds of any request and to ask for the original buyer's proof of purchase.
8. This warranty is only valid on purchases made at authorized South Shore™ Furniture retailers in Canada, the U.S., Mexico, Puerto Rico and Bermuda.
9. This warranty defines the limits of South Shore™ Furniture's liability, and entitles the original buyer to specific rights. Any warranty defined by law in your state/province is limited to a period of 5 years. If the law in your state/province prohibits this restriction, then it does not apply.
10. South Shore™ Furniture will not reimburse defective furniture, but will replace it with an item of equivalent value.

To qualify for your warranty, please take a moment to fill out our on-line registration form (southshorefurniture.com)

Afin de bénéficier de votre garantie, nous vous invitons à remplir le formulaire d'enregistrement en ligne (meublesrivesud.com)

Para obtener su garantía, tenga a bien llenar nuestro formulario en línea (southshorefurniture.com)

GARANTIE LIMITÉE DE 5 ANS

1. Meubles South ShoreMC garantit à l'acheteur original, pour une période de 5 ans à partir de la date d'achat, toutes les composantes des meubles contre les « défauts » de matériaux et de main-d'œuvre.
2. Le mot « défaut » utilisé dans cette garantie signifie une imperfection pouvant altérer l'utilité pour laquelle le produit est destiné.
3. Cette garantie se limite strictement à la réparation ou au remplacement des pièces composantes défectueuses. Cette garantie exclut tous les autres frais et dépenses directs ou indirects et ce, jusqu'à la limite permise par la législation en vigueur dans votre lieu de résidence.
4. Dans le cas d'une réclamation concernant un produit ou une pièce discontinuée, Meubles South ShoreMC s'engage à rembourser la valeur du produit ou de la pièce en question.
5. À défaut de pouvoir fournir la pièce de remplacement, la responsabilité de Meubles South ShoreMC ne peut excéder la valeur équivalente au coût de production de la pièce en litige.
6. Cette garantie s'applique sous des conditions d'usage domestique normal et ne couvre pas les défauts pouvant résulter d'un usage commercial, de dommages intentionnels, de la négligence, de l'usage abusif, de modifications personnelles, d'un accident, de l'exposition aux éléments ou d'un entretien ne respectant pas les conseils décrits sur notre site Internet.
7. Comme condition pour fournir une pièce de remplacement, Meubles South ShoreMC se réserve le droit de vérifier le fondement de la requête, de même que d'exiger la preuve d'achat de l'acheteur original.
8. Cette garantie n'est valide que si et seulement si l'achat a été effectué chez un marchand autorisé par Meubles South ShoreMC au Canada, aux États-Unis, au Mexique, à Puerto Rico et aux Bermudes.
9. Cette garantie définit les limites de la responsabilité de Meubles South ShoreMC et donne à l'acheteur original des droits spécifiques. Toute garantie législative prévalant dans votre lieu de résidence est limitée à une période de 5 ans. Si cette restriction n'est pas permise par la législation de votre lieu de résidence, elle ne s'applique pas.
10. Meubles South ShoreMC ne remboursera pas un meuble défectueux, mais le remplacera par un autre de valeur équivalente.

1. South ShoreMR garantizan al comprador original, por un período de 5 años a partir de la fecha de compra, todas las piezas que componen el mueble contra los « defectos » de material y mano de obra.
2. La palabra « defecto » utilizada en esta garantía se define como toda imperfección que pueda alterar la utilidad para la cual se destina el producto.
3. Esta garantía se limita estrictamente a la reparación o reemplazo de las piezas que tengan componentes defectuosos. Esta garantía no incluye cualquier gasto directo o indirecto hasta el límite permitido por la legislación vigente en su lugar de residencia.
4. En el caso de una reclamación referente a un producto o pieza discontinuada, South ShoreMR se compromete a reembolsar el valor del producto o pieza en cuestión.
5. A falta de poder suministrar la pieza de repuesto, la responsabilidad de South ShoreMR no puede exceder el valor equivalente al costo de producción de la pieza en litigio.
6. Esta garantía se aplica bajo las condiciones de uso doméstico normal y no cubre los defectos que puedan resultar de un uso comercial, daños intencionales, negligencia, uso abusivo, modificaciones personales, un accidente, exposición a los elementos y mantenimiento sin respetar los consejos que se describen en este sitio web.
7. Como condición para suministrar una pieza de repuesto, South ShoreMR se reservan el derecho de verificar el fundamento de la solicitud, así como de exigir la prueba de compra del comprador original.
8. Esta garantía sólo será válida si la compra se efectuó en una tienda autorizado por Muebles South ShoreMR de Canadá, Estados Unidos, México, Puerto Rico o las Bermudas.
9. Esta garantía define los límites de la responsabilidad de South ShoreMR y otorga el comprador original los derechos específicos. Cualquier garantía legislativa que prevalece en su lugar de residencia está limitada a un período de 5 años. Si esta restricción no está permitida por la legislación de su lugar de residencia, ésta no se aplica.
10. South ShoreMR no hará ningún reembolso por muebles defectuosos, pero le enviará uno de valor equivalente.

GARANTIA LIMITADA DE 5 AÑOS

CUSTOMERS SERVICE / SERVICE À LA CLIENTÈLE / SERVICIO AL CLIENTE

CANADA / USA

1-800-290-0465 

MEXICO (buzón)

01-800-522-6796 
toll free number / lada sin costo

INTERNATIONAL

418-926-2961 

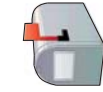

6168, Rue Principale
SAINTE-CROIX, QUÉBEC
CANADA, G0S 2H0



FAX: 1-877-586-5339
(CANADA / USA)



E-MAIL: service@southshore.ca
WEB: www.southshore.ca

